

Yeast manno-protein biosynthesis: Solubilization and selective assay of four mannosyltransferases

(multimannosyltransferases/enzyme solubilization/mannan biosynthesis)

TASUKU NAKAJIMA AND CLINTON E. BALLOU*

Department of Biochemistry, University of California, Berkeley, Calif. 94720

Contributed by Clinton E. Ballou, July 24, 1975

ABSTRACT Using appropriate yeast strains and exogenous acceptors, we have devised specific assays for four mannosyltransferase activities involved in biosynthesis of the carbohydrate outer chain of yeast mannoproteins. The assays utilize GDP-[¹⁴C]mannose as the donor and unlabeled oligosaccharides as the acceptors, the products being neutral radioactive oligosaccharides one mannose unit larger than the acceptors. The multiglycosyltransferase system from *Saccharomyces cerevisiae* was solubilized in Triton X-100 and urea and purified 100-fold. Free mannose is an acceptor for the $\alpha 1 \rightarrow 2$ -mannosyltransferase, the major product being $\alpha [^{14}\text{C}]\text{Man} \rightarrow ^2\text{Man}$. The $\alpha 1 \rightarrow 6$ -mannooligosaccharides serve as acceptors for both the $\alpha 1 \rightarrow 2$ - and $\alpha 1 \rightarrow 6$ -transferases, but the tetrasaccharide $\alpha \text{Man} \rightarrow ^3\alpha \text{Man} \rightarrow ^2\alpha \text{Man} \rightarrow ^2\text{Man}$ is a specific acceptor for the latter enzyme and yields $\alpha \text{Man} \rightarrow ^3\alpha \text{Man} \rightarrow ^3\alpha \text{Man} \rightarrow ^2\text{Man}$



When reduced, this same tetrasaccharide serves as the acceptor for an $\alpha 1 \rightarrow 3$ -mannosyltransferase from *Saccharomyces chevalieri*, yielding a pentasaccharide with two terminal 1 \rightarrow 3 linkages. Assay of the $\alpha 1 \rightarrow 3$ -transferase in *S. cerevisiae* utilizes reduced $\alpha 1 \rightarrow 2$ -mannotriose as the acceptor, the product being $\alpha [^{14}\text{C}]\text{Man} \rightarrow ^3\alpha \text{Man} \rightarrow ^2\alpha \text{Man} \rightarrow ^2\text{Mannitol}$. The multienzyme system works in concert to make "mannan" in a cell-free *in vitro* system.

Yeast cell wall manno-proteins are a heterogeneous family of complex glycoproteins. The carbohydrate, mostly mannose, is attached to the protein in two ways—as short oligosaccharides linked to serine and threonine, and as highly branched polysaccharide chains attached to asparagine through a di-*N*-acetylchitobiose unit (1). By genetic and chemical analysis, it was shown recently that the polymer chains consist of an inner core of 12–15 mannose units attached to the di-*N*-acetylchitobiose unit, and an outer chain of 50–100 mannose units that is linked to the inner core (2). Although chemically similar, these two parts of the polysaccharide chain can be distinguished by mutants that are altered in the outer chain but unchanged in the inner core.

It seems probable that the biosynthesis and secretion of such a complex macromolecule occur sequentially, with the different carbohydrate units being introduced at different times and in different places in the cell. To investigate the ordered nature of this overall process, we would like to assay the distribution of the enzymes that participate in manno-protein biosynthesis. This report describes a method for solubilization of the multimannosyltransferase system of *Saccharomyces cerevisiae* and procedures for assay of the $\alpha 1 \rightarrow 2$ -, two $\alpha 1 \rightarrow 3$ -, and the $\alpha 1 \rightarrow 6$ -mannosyltransferases that are involved in synthesis of the mannan outer chain.

Abbreviations: M, D-mannose; rM, mannitol; M₂, mannobiose; rM₂, reduced mannobiose; $\alpha \text{M} \rightarrow ^2\text{M}$, $\alpha 1 \rightarrow 2$ -linked mannobiose; GlcNAc, *N*-acetyl-D-glucosamine; *mnn*, the designator for mutations in genes concerned with mannan biosynthesis.

* To whom correspondence should be addressed.

MATERIAL AND METHODS

Materials. *Saccharomyces cerevisiae* X2180 *mnn1*, *mnn2*, and *mnn4* mutants were provided by D. L. Ballou (3) and *Saccharomyces chevalieri* was a gift from Dr. H. J. Phaff. GDP-[U-¹⁴C]mannose (160 Ci/mol) and sodium borotritide (180 Ci/mol) were from New England Nuclear, and unlabeled GDP-mannose came from Sigma. Bio-Gel P-2 (-400 mesh), P-6 (200–400 mesh), Dowex AG1-X8, and Cellex D (DEAE-cellulose) were obtained from Bio-Rad.

$\alpha 1 \rightarrow 6$ -Mannooligosaccharides were prepared by partial acetolysis of $\alpha 1 \rightarrow 6$ -mannan backbone followed by gel filtration (2). $\alpha 1 \rightarrow 2$ -Mannooligosaccharides, and mannotetraose, $\alpha \text{M} \rightarrow ^3\alpha \text{M} \rightarrow ^2\alpha \text{M} \rightarrow ^2\text{M}$, were prepared by acetolysis of *S. chevalieri* (4) and *S. cerevisiae* mannans (5), respectively. $\alpha 1 \rightarrow 3$ -Mannobiose was a gift from Dr. L. Rosenfeld. Inner core fragment from *S. cerevisiae* X2180-1A5 *mnn2* mutant was prepared as reported (2).

General Methods. Carbohydrate was determined with a phenol-sulfuric acid reagent and protein by a modified Lowry method (6). Acid hydrolysis, acetylation, acetolysis, and reduction of mannan or mannoooligosaccharides were done as described elsewhere (2).

Descending paper chromatography was done on Whatman no. 1 paper in the following solvents: A, ethyl acetate-pyridine-water (5:3:2); B, ethyl acetate-pyridine-water (8:2:1); C, ethyl acetate-acetic acid-formic acid-water (18:3:1:4). Paper electrophoresis was done on Whatman no. 1 paper in 50 mM sodium borate pH 9.2 at 20 V/cm for 8 hr. Sugars and sugar alcohols were detected with alkaline silver nitrate. Radioactivity was measured on a Packard Radiochromatogram Scanner or a Packard Tri-Carb liquid scintillation counter.

Preparation of Partially Purified Mannosyltransferases. *S. cerevisiae* cultures were grown for 12 hr at 30° with shaking in 3 liters of medium containing 2% D-glucose, 1% yeast extract, and 2% peptone in three 2-liter Fernbach flasks. All steps described below were carried out below 4° unless stated otherwise. The cells were harvested by centrifugation, washed twice with cold 1% KCl and once with 0.1 M Tris-HCl pH 7.2 containing 0.01 M dithiothreitol. The washed cells (8.3 g) were suspended in 10 ml of 0.1 M Tris-HCl pH 7.2, containing 1 mM dithiothreitol and then broken by grinding with 18 g of aluminum oxide in an ice-cold mortar for 10 min. The homogenate was fractionated by centrifugation at 4000 $\times g$ for 10 min to remove cell debris, and then at 100,000 $\times g$ for 60 min. The latter particulate fraction was treated 1 hr with 5 ml of buffer consisting of 1.5% Triton X-100 and 2 M urea (7) in 0.1 M Tris-HCl, pH 7.2. The solubilized mannosyltransferases were obtained in the supernatant by centrifugation at 100,000 $\times g$ for 60 min.

The 100,000 $\times g$ supernatant fraction, 38 mg of protein in the solubilizing buffer, was diluted 5-fold with distilled

Table 1. Purification of the mannosyltransferase system

	Protein (mg)	Activity (units)	Specific activity (units/mg of protein)	Yield (%)
4,000 × g supernatant of homogenate	1840	836	0.45	100
100,000 × g supernatant of homogenate	1750	0	0	
Triton X-100/urea extract of 100,000 × g pellet	38	769	19.4	87
Triton X-100/urea-insoluble pellet	6.3	41	6.6	
DEAE-cellulose column fractions 80–105	3.1	151	48.7	18

One unit of enzyme is the amount that will incorporate 1 pmol of mannose from GDP-[¹⁴C]mannose into exogenous acceptor per min/mg of enzyme protein when assayed under the standard conditions.

water and applied to a DEAE-cellulose column (2 × 10 cm) equilibrated with 0.02 M Tris-HCl pH 7.2 containing 1.5% Triton X-100 and 5% glycerol. The mannosyltransferase activities were eluted with a linear gradient formed with 300 ml of 0.02 M Tris-HCl pH 7.2 containing 1.5% Triton X-100 and 5% glycerol in the mixing chamber and 300 ml of 0.6 M Tris-HCl pH 7.2 containing 1.5% Triton X-100 and 5% glycerol in the reservoir. Fractions of 5 ml were collected and assayed. Active fractions 80–105 were combined and concentrated to 3 ml in an Amicon ultrafilter with a PM-10 membrane, and the concentrate was dialyzed for 6 hr against 500 ml of 0.1 M Tris-HCl containing 5% glycerol.

Standard Assay of Mannosyltransferase Activities. Incubation mixtures contained 50 mM Tris-HCl buffer pH 7.2, solubilized enzyme from *S. cerevisiae mnn4* mutant (10–30 μg of protein), 10 mM MnCl₂, 0.6 mM GDP-[U-¹⁴C]mannose (4000–6000 cpm), and 2 mM exogenous acceptor in a final volume of 50 μl. For assay of α1→2-mannosyltransferase activity, mannose was used as acceptor; for the α1→3-mannosyltransferase-I we used reduced α1→2-mannotriose, αM→²αM→²rM; and for α1→6-mannosyltransferase *S. cerevisiae* mannotetraose, αM→³αM→²αM→²M, was used. The additional α1→3-mannosyltransferase-II activity from *S. chevalieri* was assayed using reduced mannotetraose, αM→³αM→²αM→²rM. The reaction mixtures were incubated for 30 min at 25°, and then terminated; excess GDP-[U-¹⁴C]mannose was removed by passing the solution through a Dowex 1-X8 column (0.5 × 5 cm). The neutral products were eluted with 1 ml of water and the radioactivity was counted in 10 ml of Bray's solution (8).

Acceptor *K_m* values were determined in presence of 0.6 mM GDP-mannose, and donor *K_m* values in presence of 2 mM acceptor. The constants were estimated from Lineweaver-Burk plots of the data. The pH-dependence of the transferase reactions was determined on enzyme that was dialyzed against 0.01 M Tris-HCl buffer at pH 7.0 for 4 hr. The dialyzed solution was diluted prior to assay with an equal volume of 0.4 M buffer of the appropriate composition. Divalent cation requirements were determined on enzyme that had been dialyzed for 3 hr against 0.01 M EDTA in 0.1 M Tris-HCl buffer at pH 7.0 and then for 12 hr against the same buffer without EDTA.

Structural Characterization of Mannosyltransferase Products. For product analysis, reactions were scaled up 5-fold over the standard assay and a 2-hr incubation was used. The labeled product was purified on paper in Solvent A or on a Bio-Gel P-2 column (1 × 100 cm). The recovered fractions were analyzed by partial acid hydrolysis and by acetolysis. For acetolysis, the reaction was done at 40° for 12 hr (9) with unlabeled wild-type mannan added as a carrier, and the recovered deacetylated products were separated on a Bio-Gel P-2 column. For partial acid hydrolysis, the samples were treated in 0.3 M HCl at 100° for 3 hr. The hydrolysates

were fractionated on a Bio-Gel P-2 column (1 × 50 cm), and the radioactive disaccharide components were characterized by chromatography in Solvent C or by electrophoresis in borate buffer. Radioactive disaccharides were hydrolyzed with a bacterial exo-α-mannanase (10), and the products were chromatographed in Solvent B.

Synthesis of Mannan Polymer with Exogenous Acceptor. The incubation mixture contained solubilized mannosyltransferase (3 mg of protein), 100 mM unlabeled GDP-mannose, 1 mM α1→6-[³H]mannopentaitol prepared by reduction of the mannopentose with NaBT₄, and 100 mM MnCl₂, in 100 μl of 0.1 M Tris-HCl buffer pH 7.5. The reaction was followed by passing samples through a Dowex 1-X8 column (0.5 × 5 cm), after which the effluents were fractionated on a Bio-Gel P-6 column (1 × 50 cm). The labeled products recovered from the Bio-Gel P-6 were acetolyzed, and the deacetylated fragments were reduced with NaBT₄ and then chromatographed on paper in Solvent A for 17 hr.

RESULTS

Preparation of the solubilized mannosyltransferase system

The extraction system of Garewal and Wasserman (7) provided a stable enzyme preparation amenable to the usual protein purification procedures. Table 1 summarizes steps that led to a 100-fold purification. Such preparations retained at least 50% of their activity for days when stored at 0° in the presence of 5% glycerol.

All three mannosyltransferase activities were eluted together from the DEAE-cellulose column, and when assayed individually the reactions were linear for at least 60 min. The α1→6-transferase activity was stable during incubation at 30° for at least 2 hr, but inactivation occurred at higher temperature. All three transferases had broad optima at pH 7–8 in Tris-HCl buffers, whereas phosphate buffers inhibited the reaction. The reactions were activated about 50% by 10 mM Mn⁺⁺ before or after dialysis against EDTA. Mg⁺⁺ had no effect.

Demonstration of the multiplicity of mannosyltransferase activities

Fig. 1 illustrates the formation of several products, the structures being dependent on the acceptor but in each instance being one mannose unit larger. Under the assay conditions, the product is at too low a concentration to act as an acceptor for further additions. That different linkages are formed in each reaction is suggested by the results in Fig. 2. The gel filtration properties of the products and of their partial acetolysates show that some have acetolysis-stable linkages whereas others are degraded by this reaction.

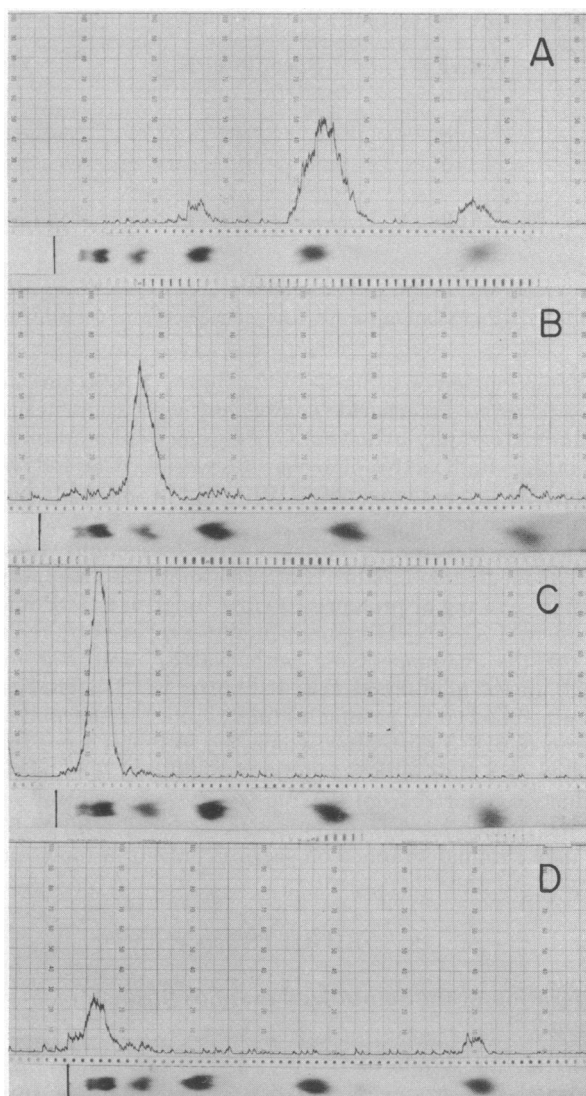

FIG. 1. Paper chromatography of the products formed by the mannosyltransferase system with GDP- ^{14}C mannose as the donor and various acceptors: (A) mannose, (B) $\alpha\text{M}\rightarrow^2\alpha\text{M}\rightarrow^2\text{rM}$, (C) $\alpha\text{M}\rightarrow^3\alpha\text{M}\rightarrow^2\alpha\text{M}\rightarrow^2\text{M}$, and (D) $\alpha\text{M}\rightarrow^6\alpha\text{M}\rightarrow^6\alpha\text{M}\rightarrow^6\text{M}$. The radioactivity detected by a paper strip scanner and the chromatograms of reference compounds stained with alkaline silver nitrate reagent are shown. From right to left, the references are mannose, mannotriose, mannotetraose, mannopentose, and mannohexose.

Specificity of the mannosyltransferase assays

By selection of mutants or acceptors, we have limited the specific transferase activity that is expressed in any one assay. Thus, mannose acts as an acceptor for the $\alpha 1\rightarrow 2$ -mannosyltransferase as demonstrated by the formation of $\alpha 1\rightarrow 2$ - ^{14}C mannobiose (Table 2). In contrast, $\alpha 1\rightarrow 6$ -mannooligosaccharides are acceptors both for the $\alpha 1\rightarrow 2$ - and $\alpha 1\rightarrow 6$ -mannosyltransferases, as shown by the formation of both ^{14}C mannose and ^{14}C mannobiose on partial acetolysis of the product (Fig. 2B). It is probable that the ^{14}C mannobiose is formed by transferases involved in synthesis of both the outer chain and the inner core because some manno-biose-yielding product was formed with this acceptor when using enzyme prepared from the *mnn2* mutant. This mutant has a defective $\alpha 1\rightarrow 2$ -transferase-I and makes mannan with an unbranched outer chain (11).

A specific assay for the $\alpha 1\rightarrow 6$ -enzyme in *S. cerevisiae*

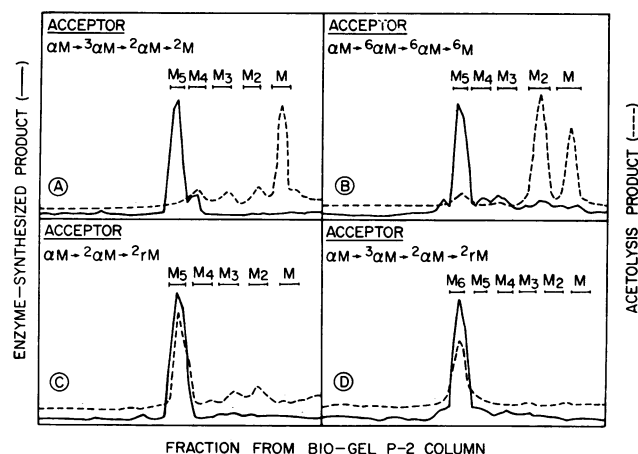

FIG. 2. Gel filtration on Bio-Gel P-2 of the radioactive products from the mannosyltransferase system with GDP- ^{14}C mannose as the donor and various acceptors indicated on the figure. Radioactive products of the enzymic reaction are indicated with a solid line, and the radioactive products formed by partial acetolysis of the enzymic products are indicated with a dashed line. Reduced oligosaccharides have elution volumes one sugar unit larger than the unreduced parent compound.

uses the mannotetraose $\alpha\text{M}\rightarrow^3\alpha\text{M}\rightarrow^2\alpha\text{M}\rightarrow^2\text{M}$, a "completed" mannan sidechain that can only accept a mannose unit in $1\rightarrow 6$ linkage (Fig. 2A and Table 2). *S. chevalieri* mannan, however, contains a pentasaccharide sidechain with a second $\alpha 1\rightarrow 3$ -linked mannose unit (4), and enzyme prepared from this yeast utilizes the reduced mannotetraose to form a mannopentose product (Fig. 2D). Finally, the $\alpha 1\rightarrow 3$ -mannosyltransferase-I of *S. cerevisiae* is assayed with

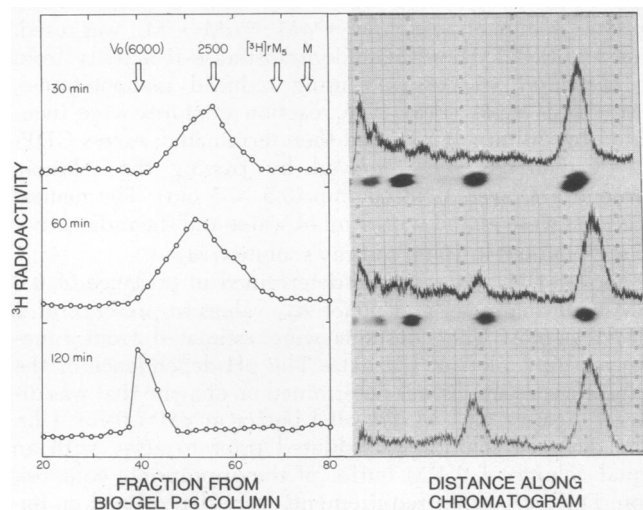

FIG. 3 (left). Fractionation on a Bio-Gel P-6 column of the products formed at different times by incubation of the solubilized mannosyltransferase system with GDP-mannose and $\alpha 1\rightarrow 6$ - ^3H mannopentaol acceptor. The elution positions of the acceptor, a reference oligosaccharide of about 15 mannose units, and the void volume, V_0 , are indicated. The sharpening of the peak of the 120-min product suggests that the material exceeds the exclusion limit of the gel.

FIG. 4 (right). Paper chromatography of partial acetolysates of the "mannan" synthesized in Fig. 3. The products isolated by gel filtration were subjected to partial acetolysis, after which the deacetylated and NaBT_4 -reduced fragments were chromatographed on paper. The figure shows the radioactive scans for incubations of 30 min (top), 60 min (middle), and 120 min (bottom). Reference strips show the positions of migration from right to left of manniitol, mannoibitol, mannotriitol, and mannotetraitol.

Table 2. Characterization of the products from mannosyltransferase reactions

Acceptor	Enzymic product	Acetolysis product	Acid hydrolysis products	Radioactive product from α -mannanase digestion	Structure of product
M	M ₂	M ₂	M→ ² M	M	α M*→ ² M
α M→ ² α M→ ² rM	rM ₄	rM ₄	M→ ³ M	M	α M*→ ³ α M→ ² α M→ ² rM
α M→ ³ α M→ ² α M→ ² M	M ₅	M	M→ ⁶ M	M	α M→ ³ α M→ ² α M→ ² M ↑ ⁶ M*
α M→ ⁶ α M→ ⁶ α M→ ⁶ M	M ₅	M + M ₂	M→ ⁶ M + M→ ² M	M	α M*→ ⁶ α M→ ⁶ α M→ ⁶ α M→ ⁶ M (40%) α M→ ⁶ α M→ ⁶ α M→ ⁶ M (60%) ↑ ² M*
α M→ ³ α M→ ² α M→ ² rM	rM ₅	rM ₅	M→ ³ M	M	α M*→ ³ α M→ ³ α M→ ² α M→ ² rM

The [¹⁴C]mannose incorporated in the enzymic reaction is identified as M*.

reduced α 1→2-mannotriose, α M→² α M→²rM, the product being a reduced tetrasaccharide (Fig. 2C). Because such a product was not formed by the *mnn1* mutant, which lacks terminal α 1→3-linked mannose units in its mannan (11), the tetrasaccharide must possess the α 1→3 linkage.

Preliminary evidence for the linkages formed by the different mannosyltransferases came from partial acetolysis studies. Thus, the products from the α 1→2- and α 1→3-mannosyltransferase reactions were stable to this treatment, whereas the α 1→6-transferase product was degraded to free [¹⁴C]mannose. Direct evidence for the assigned linkages came from the structures of the radioactive disaccharides formed by partial acid hydrolysis (Table 2). In each instance, the labeled disaccharide had the linkage consistent with the specificity of the transferase being assayed.

Cell-free biosynthesis of "mannan"

Purified enzyme from *S. cerevisiae mnn4* mutant, incubated with a high concentration of unlabeled GDP-mannose and α 1→6-[³H]mannopentaitol, gave a radioactive product (Fig. 3) of progressively increasing size with time of incubation, reaching at least 35 mannose units after 2 hr. The acetolysis pattern (Fig. 4) shows only mannose at 30 min, a consequence of the action of the α 1→6-transferase, whereas mannobiose is observed after 1 hr owing to action of the α 1→2-transferase. The absence of larger acetolysis-stable

fragments indicates that the second α 1→2-transferase (11) is not very active in this preparation; consequently, the α 1→3-transferase lacks a suitable acceptor.

Preliminary kinetic parameters of the mannosyltransferase system

The relative acceptor activities of a number of manno-oligosaccharides are given in Table 3. The α 1→6-linked homologs, which can serve as acceptors for both the α 1→2- and α 1→6-transferases, show good activity up to the heptasaccharide, at which the activity drops sharply. The reduced α 1→2-linked series shows an unusual pattern, the disaccharide having low activity, the trisaccharide a high activity, and the tetrasaccharide being inactive. We have shown that the reduced trisaccharide is an acceptor for the α 1→3-transferase-I. We suspect that the reduced disaccharide may be a poor acceptor for an α 1→2-transferase. The inactivity of the reduced α 1→2-tetrasaccharide correlates with the fact that *S. cerevisiae* mannan has no sidechain with three consecutive 1→2 linkages.

DISCUSSION

Yeast mannan biosynthesis has been studied by Behrens and Cabib (12), who described the incorporation of labeled mannose from GDP-mannose into endogenous acceptors to produce mannan-like material. Subsequently, Lehle and Tan-

Table 3. Acceptor activities of various manno-oligosaccharides

Acceptor	Relative activity
M	100
α M→ ⁶ M	245
α M→ ⁶ α M→ ⁶ M	290
α M→ ⁶ α M→ ⁶ α M→ ⁶ M	315
α M→ ⁶ α M→ ⁶ α M→ ⁶ α M→ ⁶ M	260
α M→ ⁶ α M→ ⁶ α M→ ⁶ α M→ ⁶ α M→ ⁶ M	210
α M→ ⁶ α M→ ⁶ α M→ ⁶ α M→ ⁶ α M→ ⁶ α M→ ⁶ M	87
Mannan inner core fragment (M ₁₂ GlcNAc)	38
α M→ ² rM	39
α M→ ² α M→ ² rM	250
α M→ ² α M→ ² α M→ ² rM	3
α M→ ² M	190
α M→ ² α M→ ² M	320
α M→ ² α M→ ² α M→ ² M	31
α M→ ² α M→ ² α M→ ² M	43

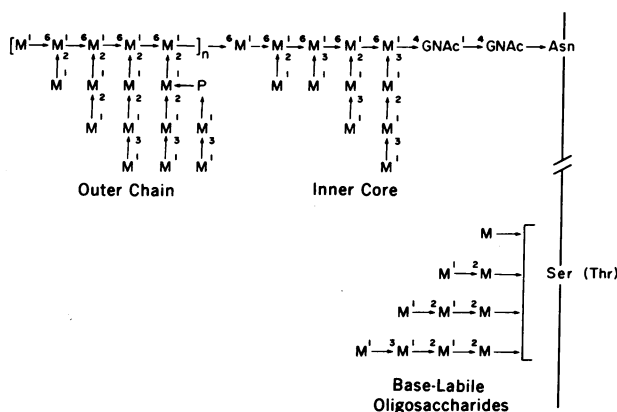

FIG. 5. Illustration of the carbohydrate portion of *S. cerevisiae* cell wall manno-protein. Some mannosyltransferases are involved in synthesis of different parts of the molecule, whereas others are limited in their function to specific parts, such as the inner core or the base-labile units.

Table 4. K_m values for the different mannosyltransferases

Acceptor	Transferase	Oligosaccharide acceptor K_m (mM)	GDP-mannose donor K_m (mM)
$\alpha M \rightarrow {}^6M$	$\alpha 1 \rightarrow 2 + \alpha 1 \rightarrow 6$	7.5	
$\alpha M \rightarrow {}^6\alpha M \rightarrow {}^6\alpha M \rightarrow {}^6M$	$\alpha 1 \rightarrow 2 + \alpha 1 \rightarrow 6$	0.2	0.5
$\alpha M \rightarrow {}^6\alpha M \rightarrow {}^6\alpha M \rightarrow {}^6\alpha M \rightarrow {}^6\alpha M \rightarrow {}^6M$	$\alpha 1 \rightarrow 2 + \alpha 1 \rightarrow 6$	0.3	
$\alpha M \rightarrow {}^3\alpha M \rightarrow {}^2\alpha M \rightarrow {}^2M$	$\alpha 1 \rightarrow 6$	4.5	0.1
$\alpha M \rightarrow {}^3\alpha M \rightarrow {}^2\alpha M \rightarrow {}^2M$	$\alpha 1 \rightarrow 6$	0.6	
$\alpha M \rightarrow {}^2\alpha M \rightarrow {}^2M$			
$\alpha M \rightarrow {}^2\alpha M \rightarrow {}^2rM$	$\alpha 1 \rightarrow 3$	2.3	0.18

ner (13) found that mannose, manno-1,6-bisectin, and mannotriose can act as exogenous acceptors, and that the disaccharide formed from mannose had the $\alpha 1 \rightarrow 2$ linkage. Farkaš *et al.* (14) reported similar results. Sharma *et al.* (15) have shown that the first mannose added to serine and threonine in manno-proteins comes from mannosyl dolichol phosphate, and that subsequent mannose units probably are derived directly from GDP-mannose.

In this study, we have designed specific assays for four of the mannosyltransferases in yeast mannan biosynthesis, using exogenous acceptors and a solubilized enzyme system. The complexity of the carbohydrate component in yeast manno-proteins (Fig. 5) suggests that a minimum of 10 mannosyltransferases must be involved in its biosynthesis. Genetic evidence indicates that formation of all of the terminal $1 \rightarrow 3$ -linked mannose units is controlled by a single gene, because a mutant (designated *mnn1*) simultaneously lost this component in all positions (11). By direct assay, we have now demonstrated this enzymatic activity in wild-type *S. cerevisiae* and its absence in the *mnn1* mutant.

The mannotetraose unit is the longest sidechain in *S. cerevisiae* mannan. However, several *Saccharomyces* species, interfertile with *S. cerevisiae*, make mannan with a pentasaccharide sidechain by adding another mannose in $\alpha 1 \rightarrow 3$ linkage (4). We have now demonstrated this $\alpha 1 \rightarrow 3$ -mannosyltransferase-II activity in *S. chevalieri* extracts.

The first sidechain mannose unit in *S. cerevisiae* mannan is attached to the $\alpha 1 \rightarrow 6$ -linked backbone by an $\alpha 1 \rightarrow 2$ linkage. The *mnn2* mutant, which makes mannan with an unsubstituted outer chain, has now been shown to lack the $\alpha 1 \rightarrow 2$ -mannosyltransferase-I associated with this structure. Some acetolysis-resistant disaccharide product is made by extracts from this mutant, which probably reflects the activity of an inner core transferase. The $\alpha 1 \rightarrow 2$ -transferases that make the oligosaccharides attached to the hydroxyamino acids are not expected to act on the $\alpha 1 \rightarrow 6$ -mannooligosaccharide acceptors.

The $\alpha 1 \rightarrow 6$ -mannosyltransferase synthesizes the mannan backbone, and a demonstration of this enzyme activity with an exogenous acceptor has not been reported previously in yeast, although a similar enzyme activity is found in *Cryptococcus laurentii* (16). In our system, this transferase is demonstrated by the addition of a new mannose unit in $1 \rightarrow 6$ linkage to the acceptor $\alpha M \rightarrow {}^3\alpha M \rightarrow {}^2\alpha M \rightarrow {}^2M$.

From preliminary kinetic studies, we have sought some hint as to how the activities of the different enzymes might be regulated to produce a mannan of characteristic size and degree of branching (Table 4). The order of affinities of the transferases for the donor GDP-mannose is $\alpha 1 \rightarrow 6 > \alpha 1 \rightarrow 3 > \alpha 1 \rightarrow 2$, so the sugar nucleotide concentration could affect the relative activities of these three enzymes. On the other

hand, the affinities for the acceptors vary considerably depending on their structures. Thus, the $\alpha 1 \rightarrow 6$ -transferase has a lower K_m for the acceptor consisting of two sidechain fragments connected by a $1 \rightarrow 6$ linkage than it does for the single mannotetraose sidechain, a reasonable observation since the former more nearly mimics the structure of the growing end of a mannan chain. The K_m of the mixed $\alpha 1 \rightarrow 2$ - and $\alpha 1 \rightarrow 6$ -transferase system for the $\alpha 1 \rightarrow 6$ -mannooligosaccharide acceptors decreased sharply in going from the di- to the tetrasaccharide, again probably a reflection of the closer approximation to the structure of the natural acceptor.

If the mannosyltransferases described here are involved in mannan biosynthesis, it is expected that they would act in concert to produce macromolecular material with the properties of mannan. We have shown this to occur when the enzyme preparation from *S. cerevisiae* wild-type is incubated for an extended time with the $\alpha 1 \rightarrow 6$ -mannopentaitol acceptor and a high concentration of GDP-mannose. Polysaccharide material is formed with a molecular size exceeding the exclusion limit of Bio-Gel P-6 as a result of the action of both the $\alpha 1 \rightarrow 6$ - and $\alpha 1 \rightarrow 2$ -mannosyltransferases.

This study was supported by National Science Foundation Grant GB-35229X and by U.S. Public Health Service Grant AM884.

- Ballou, C. E. (1974) *Adv. Enzymol.* **40**, 239-270.
- Nakajima, T. & Ballou, C. E. (1974) *J. Biol. Chem.* **249**, 7685-7694.
- Ballou, D. L. (1975) *J. Bacteriol.*, **123**, 616.
- Ballou, C. E., Lipke, P. N. & Raschke, W. C. (1974) *J. Bacteriol.* **117**, 461-467.
- Lee, Y. C. & Ballou, C. E. (1965) *Biochemistry* **4**, 257-264.
- Wang, C. E. & Smith, R. L. (1975) *Anal. Chem.* **63**, 414-417.
- Garewal, H. S. & Wasserman, A. R. (1974) *Biochemistry* **13**, 4063-4071.
- Bray, G. A. (1960) *Anal. Biochem.* **1**, 279-285.
- Rosenfeld, L. & Ballou, C. E. (1974) *Carbohydr. Res.* **32**, 287-298.
- Jones, G. H. & Ballou, C. E. (1969) *J. Biol. Chem.* **244**, 1043-1051.
- Raschke, W. C., Kern, K. A. & Ballou, C. E. (1973) *J. Biol. Chem.* **248**, 4660-4666.
- Behrens, N. H. & Cabib, E. (1968) *J. Biol. Chem.* **243**, 502-509.
- Lehle, L. & Tanner, W. (1974) *Biochim. Biophys. Acta* **350**, 225-235.
- Farkaš, V., Vagabov, V. M. & Bauer, Š. (1974) *Abstracts VII International Symposium on Carbohydrate Chemistry*, pp. 228.
- Sharma, C. B., Babczinski, P., Lehle, L. & Tanner, W. (1974) *Eur. J. Biochem.* **46**, 35-41.
- Schutzbach, J. S. & Ankel, H. (1971) *J. Biol. Chem.* **246**, 2187-2194.