

PLANT CULTURE EQUIPMENT

FRANK M. EATON

(WITH FOUR FIGURES)

Introduction

A detailed description is presented in this paper of small sand and water culture equipment. A number of large out-of-doors sand cultures both for tree and annual crops have also been constructed at the U. S. Regional Salinity Laboratory, Riverside, California. In their general features these latter cultures are like those described in an earlier publication (3). The more significant modifications are discussed.

The same principle of operation is used in all of the sand culture equipment. Briefly stated, each sand culture consists of a sand bed and a solution reservoir. Nutrient solution is pumped from the reservoir onto the surface of the sand at hourly or other selected intervals. The solution applied to the surface of the sand displaces to the reservoir a large part of the solution remaining in the sand from the previous flushing. Drainage to the reservoirs is provided by the use of a permeable aluminum silicate material manufactured in the form of bricks for the insulation of furnaces. These bricks (or discs) confine root growth to the sand and thus prevent the stoppage of drains. Inasmuch as the intervals of application of solution to the sand are controlled by time clocks, a minimum of manual attention is required.

Small sand cultures

The stoneware cultures, figures 1 to 3, were designed for nutritional studies in the greenhouses where the effects of a number of treatments are compared in replicated cultures. While the equipment shown was intended primarily for small plants, its usefulness for large plants is indicated by the tomatoes in figure 2. For use with large plants advantages of larger reservoirs are indicated, since the frequency with which new solutions are substituted for old ones, or the frequency with which determinations and additions of nutrient ions are made, can thereby be reduced. The pottery company that has cooperated in the manufacture of the stoneware has advised that they can build 35- or 40-liter stoneware reservoirs with bell-shaped tops that would accommodate the present sand trays and other fittings.

CHAPMAN'S and LIEBIG'S idea (1) of using air-lift pumps has been adopted in these cultures. These investigators made use of large earthenware tile reservoirs set in greenhouse floors.

The sand cultures shown in figure 3 are mounted on a rotating table to produce uniform conditions in an unevenly lighted greenhouse. Com-

pressed air is brought into the center of the revolving table through a mercury sealed connection. The revolving portion of the table top rests on the wheel assembly of a heavy truck trailer. The axle of this assembly is set in a concrete-filled excavation beneath the greenhouse floor.

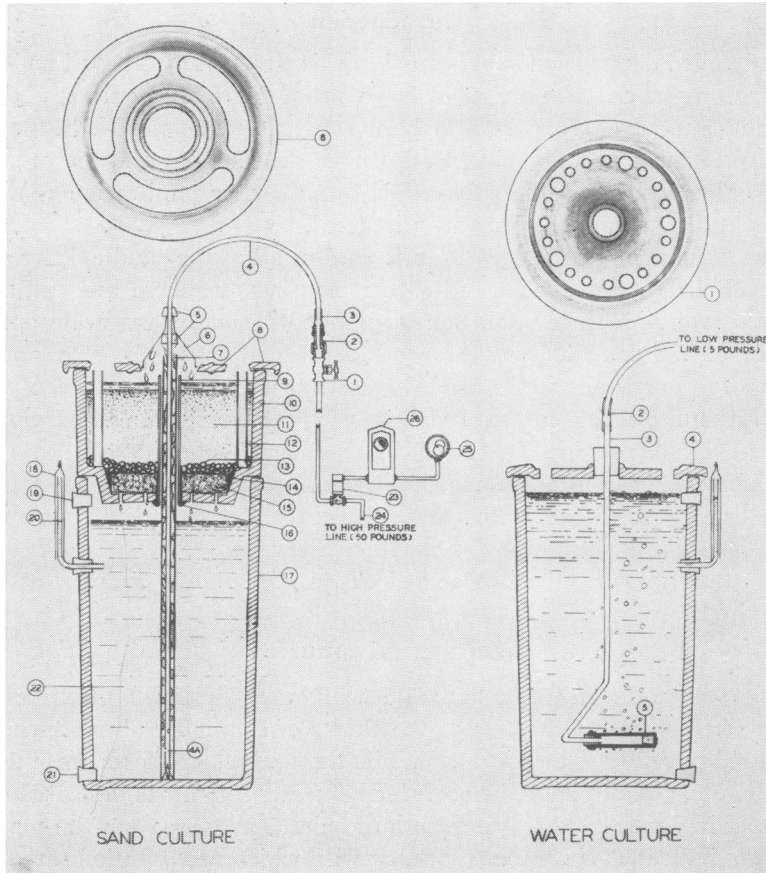

FIG. 1. Cross section view of sand culture (left) and water culture (right).

The following paragraphs, numbered to correspond to the designations of the parts in figure 1, left, describe the character of the various pieces of the sand culture equipment:

1. *Air valve*.—This is a $\frac{1}{4}$ -inch needle valve of the less expensive type. It is used for adjusting the rate of flow of air from the outlet at 4a. The valve has male threads at both ends (fig. 2, left).

2. *Hose connector*.—This $\frac{1}{4}$ -inch acetylene-welder type of connection has



FIG. 2. Sand cultures on greenhouse benches.



FIG. 3. Sand cultures mounted on a rotating table in unevenly lighted greenhouse.

a hexagonal nut which permits ready disconnection of the air line when the cultures are to be dissembled.

3. *Koroseal tubing*.—Tubing of this type¹ (suggested by L. A. RICHARDS) stands up under greenhouse light conditions much better than rubber tubing. It is heated in a water bath before being set in place.

4. *Air-discharge tubes*.—Soft aluminum tubing with $\frac{1}{4}$ -inch outside diameter. A $\frac{1}{32}$ -inch hole is bored through one wall at 4a to emit air. The lower end is closed by clamping it in a machine vise.

5. *Funnel supports*.—These are the two halves of a no. 2 rubber stopper.

6. *Aluminum funnel*.—Outside diameter of base, $2\frac{3}{4}$ inches.

7. *Solution delivery tube*.—Hard thin-walled aluminum tubing $22\frac{3}{4}$ inches long with $\frac{3}{4}$ -inch outside diameter. V-notches $\frac{3}{4}$ -inch deep are cut on opposite sides of the lower end to provide inlets for the solution. The delivery rate of solution by this tubing with an inside diameter of 17 mm. in single tests was 2.6 liters per minute compared with a rate of 1.3 liters per minute from a tube with 13-mm. inside diameter. Corrosion of this tubing can be delayed by dipping it in Bakelite varnish.²

8. *Glazed stoneware covers*.—These are used to suppress growth of algae and check surface evaporation. Slips of sheet aluminum or cardboard with U-shaped notches for the plant stems are laid over the openings in the cover after the plants have been thinned to final number.

9. *Glass sleeve and overflow*.—Pyrex glass tubing with inside diameter of 22 mm. and outside 30 mm., length 17 cm. To seal in place, the glass tube is extended through the circular opening in porous disc, 15, and bottom of the tray, 10, letting the lower end of the tube rest on the work bench. After placing a centimeter depth of coarse sand in the bottom of the V-shaped opening around the porous disc, hot G-K compound, 14, is poured in with a spoon until the groove is filled. A thin rim of G-K compound is then built up on the disc around tube. When this material has hardened, the tray is inverted and hot red sealing wax is added to fill up the space between the tube and rim of the opening in the bottom of the tray. The top of the overflow tube should now be about 1.5 cm. below the top of the tray.

10. *Sand tray*.—This piece of stoneware has a volume of about 6.5 liters.

11. *Quartz sand and magnetite*.—Five kilograms of sand is mixed with 25 grams of powdered magnetite, $\text{FeO} \cdot \text{Fe}_2\text{O}_3$. The layer of gravel in the bottom of the tray should be wetted before adding the sand. A sand, of which 50 per cent. is retained by a 60-mesh screen after passing a 40-mesh

¹ Supplied by B. F. Goodrich Company, size $\frac{3}{16}$ -inch inside diameter, with $\frac{1}{8}$ -inch wall thickness.

² A hard rubber tubing supplied by Kirkhill Rubber Company, Los Angeles, California, with $\frac{22}{32}$ -inch inside diameter and $\frac{25}{32}$ -inch outside diameter, also appears to be satisfactory in preliminary trials and it is somewhat less expensive.

screen, has been found to be satisfactory.³ In solutions at pH 6, the magnetite has supplied ample iron to all plants tested (1, 2, 3).

12. *Air vents*.—Without these glass tubes which extend into the gravel, air is locked in the sand when the trays are flushed, thus preventing a free, uniform, downward movement of solution.

13. *Quartz gravel*.—One kilogram of gravel of a size which passes a 4-mesh screen and is held on an 8-mesh screen is suitable. The sand does not work down into the gravel if the latter is wetted before filling.

14. *Asphalt compound*.—This product, which is sold under the trade name G-K sewer-joint compound, has a rather low melting point, but it maintains a good union with the glazed walls of the sand tray when it cools.⁴

15. *Porous disc*.—These are purchased in 6½-inch squares 1 inch thick. A 30-mm. hole is first bored through the center on a press drill with a steel tube. From 10 to 14 of them are then strung on a 30-mm. rod, clamped into a lathe, and then turned down to a diameter of 6½ inches. The material works easily. The permeability of the discs is about 600 ml. per minute when the trays are filled with sand and the solution is at the height of the overflow.

16. *Red sealing wax*.—This is used to seal the overflow tubes, 9, into the bottoms of the sand trays. Five grams of finely powdered sealing wax added to a liter of culture solution has been found to be somewhat toxic to tomato plants in water cultures. The small solid piece used in this seal has shown no ill effects.

17. *Reservoir*.—The jars shown have a capacity of 14.5 liters. They have three outlets, each of which takes a no. 2 rubber stopper. The opening at 19 is set 4 inches to the right of those at 20 and 21.

18. *Cap for water gauge*.—This is a piece of ½-inch aluminum tubing with one end closed. Its use prevents the growth of algae in the gauge.

19. *Water-addition opening*.—In replenishing solutions, this stopper is removed and the point of a self-closing radiator faucet inserted.

20. *Water gauge*.—This is a 5- or 6-mm. glass tube bent in the shape shown and painted black below cap.

21. *Outlet for emptying reservoirs*.

22. *Culture solution*.—Salts for 13 liters are used in making up 11 liters of solution. Two liters of water are then added to the surface of the sand and when draining has stopped, a wax mark is made on the water level gauge to indicate the initial volume. The five kilograms of sand retain between 1.6 and 1.8 liters of solution against gravity.

³ This sand is supplied by the Industrial Sands Division, Corona, California.

⁴ Atlas Mineral Products Company, The Deming Company, 4227 Whiteside Avenue, Los Angeles, California.

23. *Magnetic air valve.*⁵

24. *Air pressure line.*—Air pressures up to about 50 pounds are satisfactory. Where a large number of cultures are operated from a single air line, the latter pressure beyond the pressure regulator is desirable. A discharge rate of 0.7 cu. ft. of air per minute per culture gives a satisfactory solution delivery rate.

25. *Time switch.*—The General Electric TSA-14 time switch can be used alone without time-switch 26 if the cultures are flushed each hour throughout the 24 hour period. This timer makes a complete cycle every 60 minutes. The duration of the “on” period can be set for any fraction of the 60-minute period. Three minutes are ample for the complete replacement of the solution held by the sand, providing air pressures are maintained.

26. *Time switch.*⁶—This switch is connected in series with switch 25 in such a way that the circuit to the magnetic valve is completed only during an “on” period of both timers. The “on” and “off” pins on the 24-hour dial of the Sangamo timer cannot be inserted nearer together than 15 minutes. This switch is used to limit the flushing of the sand trays to selected hours.

Water cultures

In using the sand-culture solution reservoirs as water cultures, the air hose leading from each greenhouse bench is disconnected from the non-continuous high-pressure air line and attached to a continuous low pressure outlet. Carbon-tube aerators are employed following a suggestion originating with P. R. STOUT and D. I. ARNON of the University of California.

1 and 4. *Glazed stoneware cover.*—Two sizes of tapered holes are provided in this cover for mounting seedlings of various sized plants. The cotton mountings for seedlings stay in place better if the holes are not glazed.

2. *Rubber or Koroseal connection.*

3. *Glass or ¼-inch aluminum tubing.*

5. *Aerator.*—Plain carbon pipe,⁷ diameter inside ½-inch, outside ¾-inch. Five pounds of air pressure can be used without blowing the cork stoppers if they are inserted after having been dipped in hot G-K Compound.

Stoneware

The stoneware described is manufactured⁸ in accordance with specifications. Plain solid covers to fit trays and reservoirs of this size are available at nominal cost.

⁵ Made by Magnetic Controls.

⁶ Sangamo Type TC-11 (sold by Graybar Electrical Co.).

⁷ Supplied by National Carbon Company, Inc.

⁸ By the Pacific Clay Products, 306 West Avenue 26, Los Angeles, California. Reservoirs (U. S. 3), \$1.00; sand trays (U. S. 4), 60 cents; water-culture covers (U. S. 5) 50 cents; and sand-tray covers (U. S. 6), 60 cents.

The squares of insulating brick were cut to order (1 inch by $6\frac{1}{4}$ inches).⁹ There are a number of insulating bricks of similar composition and volume weight on the market, but the Vitrefrax has been the only one so far tested that had a high permeability.

The other pieces of the equipment are all standard products and the prices would accordingly vary with location and purchasing conditions.

Large out-of-doors sand cultures for annual and tree crops

The new sand cultures for annual crops grown to maturity, figure 4, have dimensions similar to the one previously described (3, fig. 2) except that the



FIG. 4. Out-of-doors sand cultures for annual crops.

depth of the reservoir has been increased from 18 to 29 inches, giving a capacity of 2,400 liters. Asphalt painted transite in pieces $\frac{1}{4}$ -inch thick are used in place of tin to suppress the growth of algae. The motor pump is placed in a housing at the end of the bed below the upper level of the solution. Aluminum silicate brick are used for drainage in place of gravel. The ends of 39 standard size brick ($2 \times 4.5 \times 9$ inches) are bevelled so that they rest on the correspondingly bevelled edges of the concrete cross tile. The walls of these unit type beds are 6 inches thick, thus permitting the use of a recess rather than angle iron to support the transite.

⁹ Furnished by the Vitrefrax Corporation, 5050 Pacific Blvd., Los Angeles, California, in lots of 100 at 35 cents each.

The 18 deep sand beds for tree crops at the U. S. Regional Salinity Laboratory, Riverside, California, have inside dimensions of $5 \times 10 \times 6$ feet deep. They are spaced 10×18 feet center to center. Whole permeable brick are laid above drainage ways cast in the concrete floor. A number of tubes for the escape of air during flushing are extended into the gravel laid above the permeable brick. The inside dimensions of the reservoirs are $7 \times 4 \times 6$ feet deep.

A high silica cement-lined pipe sold under the trade name "Durolite" is used for all plumbing with promising results from the standpoint of corrosion.

The concrete walls of these cultures are made nearly impermeable and chemically inert by a two-coat sprayed-on dressing of emulsified asphalt.¹⁰

BUREAU OF PLANT INDUSTRY
RIVERSIDE, CALIFORNIA

LITERATURE CITED

1. CHAPMAN, H. D., and LIEBIG, G. F. Adaption and use of automatically operated sand-culture equipment. *Jour. Agr. Res.* **56**: 73-80. 1938.
2. ————. Absorption of iron from finely ground magnetite by citrus seedlings. *Soil Sci.* **48**: 309-315. 1939.
3. EATON, F. M. Automatically operated sand-culture equipment. *Jour. Agr. Res.* **53**: 433-444. 1936.

¹⁰ The material used is sold under the name "Static Protective Coating" by The Flintkote Company.