

Multiple crm^- Mutations in Familial Hypercholesterolemia

Evidence for 13 Alleles, Including Four Deletions

Helen H. Hobbs, Eran Leitersdorf, Joseph L. Goldstein, Michael S. Brown, and David W. Russell

Departments of Molecular Genetics and Internal Medicine, The University of Texas Health Science Center at Dallas, Dallas, Texas 75235

Abstract

The low density lipoprotein (LDL) receptors in fibroblasts from 132 subjects with the clinical syndrome of homozygous familial hypercholesterolemia were analyzed by immunoprecipitation with an anti-LDL receptor monoclonal antibody. 16 of the 132 cell strains (12%) synthesized no immunodetectable LDL receptor protein, indicating the presence of two mutant genes that failed to produce cross-reacting material (crm^- mutations). DNA and mRNA from 15 of the 16 crm^- patients, representing 30 crm^- genes, were available for further study. Haplotype analysis based on 10 restriction fragment length polymorphisms (RFLPs) suggested that the 30 crm^- genes represent 13 mutant alleles. Four of the alleles produced no mRNA. Three of these four mRNA⁻ alleles had large deletions ranging from 6 to 20 kb that eliminated the promoter region of the gene. The fourth mRNA⁻ allele did not contain any deletion or alteration in the promoter sequence; the reason for the mRNA⁻ phenotype was not apparent. Nine alleles were positive for mRNAs, of which three encoded mRNAs of abnormal size. One of the abnormal mRNAs was produced by a gene harboring a deletion, and another was produced by a gene with a complex rearrangement. The third abnormal-sized mRNA (3.1 kb larger than normal) was produced by an allele that had no detectable alterations as judged by Southern blotting. The other six mRNA⁺ alleles appeared normal by Southern blotting and produced normal-sized mRNA but no receptor protein. The current studies demonstrate that mRNA analysis coupled with haplotype determination by Southern blot analysis can be used to classify crm^- mutations at a genetic locus where multiple alleles exist.

Introduction

Familial hypercholesterolemia (FH)¹ is an autosomal dominant disorder caused by mutations in the gene for the LDL receptor (1). This cell-surface receptor carries out two important functions in maintaining cholesterol homeostasis (2). First, it supplies cells with cholesterol for membrane synthesis by binding to plasma LDL particles and bringing them into the cell by receptor-mediated endocytosis. Second, the receptor

helps to maintain low plasma levels of these potentially atherogenic particles by clearing them from the circulation. A mutation in one LDL receptor gene is found in about 0.2% of individuals in most populations (1). These individuals, who are designated FH heterozygotes, produce one-half the normal number of LDL receptors, and consequently they have plasma LDL-cholesterol levels that are approximately twice the normal value. The increase in plasma LDL leads to premature atherosclerosis and an increased incidence of myocardial infarction in the fourth and fifth decades. In subjects with homozygous FH, both LDL receptor alleles bear mutations, the number of functional LDL receptors is severely reduced, and plasma LDL levels are more than five times higher than normal. Homozygous FH is found in one in one million individuals and is usually fatal before the age of 30, owing to coronary atherosclerosis (1).

The LDL receptor has been purified to homogeneity (3), and antireceptor monoclonal antibodies have been developed (4). When used as probes, these antibodies have revealed that FH is genetically heterogeneous (5, 6). At least four different classes of mutations can be distinguished. These disrupt synthesis, intracellular transport, LDL binding ability, or internalization of the LDL receptor (2, 7). Recently, we have isolated cloned DNAs corresponding to the human LDL receptor mRNA (8) and gene (9). Studies using these DNA probes have revealed that the LDL receptor gene spans about 45 kb of DNA on the distal short arm of chromosome 19 (9, 10). The gene is divided into 18 exons and 17 introns (9) and encodes a mature mRNA of 5.3 kb (8).

Through cloning and DNA sequencing, we have begun to analyze the molecular basis of the four classes of FH mutations (11–18). One class whose study is particularly facilitated by the availability of DNA probes are those that block the synthesis of the LDL receptor protein (so-called class 1 mutations). These mutations are referred to as crm^- alleles since they fail to produce cross-reacting material (crm) when studied immunologically. The availability of cloned DNAs allows one to define the RNA phenotype of a crm^- allele and to assess directly its genotype.

In the current studies, we have undertaken an extensive survey of crm^- alleles using both immunological and DNA probes. These studies reveal four different deletions and one complex rearrangement in the LDL receptor gene and indicate that crm^- alleles occur on at least 13 different chromosomal backgrounds, suggesting the existence of at least 13 different mutations in this class.

Methods

Materials. IgG-C7, a mouse monoclonal antibody that binds to the human LDL receptor, and IgG-2001, a control mouse monoclonal antibody directed against an irrelevant antigen, were prepared as previously described (5). Human lipoprotein-deficient serum ($d > 1.215$

Received for publication 22 July 1987 and in revised form 22 September 1987.

1. Abbreviations used in this paper: crm^- , negative for cross-reacting material; FH, familial hypercholesterolemia; RFLP, restriction fragment length polymorphism.

J. Clin. Invest.

© The American Society for Clinical Investigation, Inc.

0021-9738/88/03/0909/09 \$2.00

Volume 81, March 1988, 909–917

g/ml) was prepared as previously described (19). Restriction enzymes used in DNA blotting experiments were obtained from New England Biolabs (Beverly, MA) and Boehringer Mannheim Biochemicals, Inc. (Indianapolis, IN). DNA polymerase I (Klenow fragment) was obtained from Boehringer Mannheim Biochemicals, Inc. [α - 32 P]CTP (3,000 Ci/mmol) and [35 S]methionine ($\sim 1,100$ Ci/mmol) were purchased from New England Nuclear (Boston, MA). Zeta Probe nylon membranes were obtained from Bio-Rad (Richmond, CA), and Bio-trans nylon membranes were from ICN Biomedicals Inc. (Irvine, CA). Hoechst dye No. 33258 was obtained from Polysciences, Inc. (Warrington, PA).

Immunochemical analysis of [35 S]methionine-labeled LDL receptors. Human fibroblasts were obtained from skin biopsy specimens and grown in monolayer culture at 37°C in 5% CO₂. Approximately 3×10^4 cells from stock cultures were seeded into 60-mm Petri dishes according to a standard protocol and cultured for 5 d (19). Maximal synthesis of LDL receptors was induced by incubation in human lipoprotein-deficient serum for 16 h before study (19). For radiolabeling, the cells were preincubated in methionine-free DME for 30 min and then pulse-labeled with [35 S]methionine (90–110 μ Ci/ml) for 2 h at 37°C in the same medium. The cells were then incubated in complete medium for 2 h at 37°C (6). LDL receptors were immunoprecipitated from detergent-solubilized cell extracts with a monoclonal antibody (IgG-C7) directed against the ligand binding domain of the LDL receptor (6). As a control, an irrelevant monoclonal antibody (IgG-2001) was also employed (6). The immunoprecipitates were subjected to SDS-PAGE under reducing conditions and autoradiography was performed as described (6). Apparent molecular weights of the 35 S-labeled proteins were calculated from the migration positions of marker proteins (6).

Southern blotting analysis. Genomic DNA was isolated from cultured fibroblasts or peripheral blood as described (15) and digested for at least 2 h with 5–10 U of restriction enzyme per μ g of DNA in the presence of the buffer suggested by the manufacturer. After quantification by a fluorescence assay (20) using Hoechst dye No. 33258, 5 μ g of DNA was redigested with a twofold unit excess of enzyme. The DNA was then electrophoresed on 0.8% agarose gels and transferred to Biotrans nylon membranes. Single-stranded 32 P-labeled probes derived from the LDL receptor cDNA (8) were prepared by the methods of Church and Gilbert (21) and hybridized (5×10^6 cpm/ml) to filters at 42°C for 16 h in 50% (vol/vol) formamide, 0.05% (wt/vol) each of BSA, Ficoll 400, and polyvinyl pyrrolidone 360, $5 \times$ SSPE (0.9 M NaCl, 50 mM sodium phosphate, and 5 mM EDTA, pH 7.4), 1% (vol/vol) SDS, and 100 μ g/ml of denatured and sonicated salmon sperm DNA. After hybridization, filters were washed 4 h at 68°C in $0.5 \times$ SSC (75 mM NaCl and 7.5 mM sodium citrate) and 1% (vol/vol) SDS and subjected to autoradiography on Kodak XAR-5 film with intensifying screens.

RNA blotting analysis. Diploid human fibroblasts were cultured and induced for maximum expression of LDL receptors using a previously described protocol (17). Total RNA was isolated from cells by a guanidinium HCl procedure and analyzed by blotting after electrophoresis in glyoxal-containing agarose gels. Conditions for hybridization, probe synthesis, and washing were as described previously (17).

Haplotype analysis. DNA samples were digested with each of the restriction enzymes known to result in polymorphic patterns and analyzed by Southern blotting with the appropriate probes. Previously reported restriction enzymes that reveal restriction fragment length polymorphisms (RFLPs) in the LDL receptor gene include: Stu I (22), Pvu II (23, 24), Ava II (25), Apa I (26), Pst I (27), and Nco I (28). In addition, three previously unreported DNA polymorphisms for the enzymes Bsm I, Sph I, and Spe I were analyzed (Leitersdorf, E., J. L. Goldstein, M. S. Brown, and H. H. Hobbs, manuscript in preparation).

Results

To identify *crm*⁻ alleles at the LDL receptor locus, we screened 132 fibroblast cell strains established from subjects with the

clinical syndrome of homozygous FH. Cells were pulse-labeled with [35 S]methionine, chased for 2 h in the presence of excess unlabeled methionine, solubilized with detergent-containing buffers, and then subjected to immune precipitation with a monoclonal antibody (IgG-C7) directed against the LDL receptor (Fig. 1). In normal cells this antibody precipitated an LDL receptor of 160 kD. This protein was not precipitated by an antibody directed against an irrelevant antigen (IgG-2001) (Fig. 1A). 16 of the 132 FH cell strains showed no cross-reacting material with the IgG-C7 antibody. Three representative examples (FH 664, 132, and 551) are shown in Fig. 1, A and B. Each of the 16 *crm*⁻ individuals came from a separate family (Table I). Their ethnic backgrounds were diverse, and with only three exceptions parental consanguinity was denied. Four of these subjects (FH 49, 549, 808, and 859), who are of French Canadian descent, were described in detail in a previous study (29); they are included here for completeness.

We assayed 15 of the 16 *crm*⁻ FH cell lines for their content of LDL receptor mRNA (Fig. 2). Cells from the 16th subject (FH 250) were not available for analysis. Cells were cultured in the absence of exogenous lipoproteins to induce maximum expression of the LDL receptor mRNA, and total RNA was isolated by a guanidinium hydrochloride procedure and subjected to electrophoresis in agarose gels containing glyoxal. After transfer to nylon membranes, the immobilized RNA was hybridized to a mixture of 32 P-labeled cDNA probes complementary to three different regions of the LDL receptor mRNA. As a control for RNA loading, a probe complementary to the human β -actin mRNA was included in the hybridization solution. In five of the cell strains (FH 26, 49, 549, 808, and 859), no LDL receptor mRNA could be detected (Fig. 2A and E), even after deliberate overexposure of the autoradiogram (Fig. 2B). Normal amounts of β -actin mRNA were visualized in all of these lanes. Of these five subjects, four are of French Canadian descent (Table I), and we have previously shown that their failure to synthesize mRNA is a consequence of a > 10-kb deletion in the LDL receptor gene that removes the promoter region and exon 1 (29). The fifth individual (FH 26), an American, does not have this deletion (see below).

Seven of the *crm*⁻ cell lines (FH 61, 431, 485, 573, 664, 790, and 842) produced a normal-sized mRNA of 5.3 kb (Fig. 2A, C, and D), while one individual (FH 551) had both a normal mRNA and an elongated species of 8.4 kb (Fig. 2A).

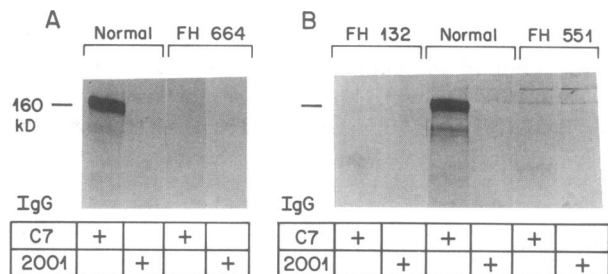

Figure 1. Electrophoresis of 35 S-labeled LDL receptors from a normal subject and three subjects with homozygous FH. Fibroblasts from the indicated subject were pulse-labeled for 2 h with [35 S]methionine and chased with unlabeled methionine for 2 h. The cell extracts were processed by immunoprecipitation with either mouse monoclonal antireceptor IgG-C7 or control monoclonal IgG-2001, followed by SDS gel electrophoresis as described in Methods. The dried gels were exposed to XAR-5 x-ray film for 2–4 d at -70°C .

Table I. Clinical and Genetic Data on FH Homozygotes with *crm*⁻ Phenotype

| FH homozygote | | | | | | | LDL receptor gene | | |
|---------------|----------|-----|-----|------------------|--------------------------|---------------------------|---|------------------|-------------|
| Number | Initials | Age | Sex | Ethnic origin | History of consanguinity | Size of LDL receptor mRNA | Functional region deleted or rearranged | Size of deletion | Haplotypes* |
| | | yr | | | | kb | | | |
| | | | | | | | | kb | |
| 49 | A.C. | 33 | F | French Canadian | Yes | — | Promoter & Exon 1 | >10 | aa |
| 549 | R.T. | 3 | M | French Canadian | No | — | Promoter & Exon 1 | >10 | aa |
| 808 | R.J. | 4 | F | French Canadian | No | — | Promoter & Exon 1 | >10 | aa |
| 859 | V.P. | 7 | F | French Canadian | No | — | Promoter & Exon 1 | >10 | aa |
| 26 | J.P. | 14 | F | American | No | —/— | Compound heterozygote: None detected | | bc |
| | | | | | | | Promoter & Exon 1 | ~6 | |
| 132 | O.C. | 18 | F | Portugese | No | —/6.2 | Compound heterozygote: Exons 1–18(?) | >40(?) | de |
| | | | | | | | Complex rearrangement [‡] | | |
| 431 | J.L. | 30 | M | American | No | 5.3 | None detected | | ff |
| 485 | A.M. | 12 | M | Colombian | No | 5.3 | None detected | | ff |
| 664 | T.H. | 21 | F | American | No | 5.3 | None detected | | ff |
| 842 | L.C. | 21 | F | Italian | No | 5.3 | None detected | | gg |
| 61 | D.R. | 6 | F | Italian-American | Yes | 5.3 | None detected | | hh |
| 250 | P.A. | 24 | F | Greek-Cypriot | No | ND [§] | None detected | | hh |
| 551 | T.S. | 31 | F | Japanese | No | 5.3/8.4 | None detected | | ii |
| 790 | Z.Y. | 27 | F | Chinese | No | 5.3 | None detected | | jk |
| 573 | M.C. | 7 | F | French | No | 5.3 | None detected | | ll |
| 651 | M.M. | 8 | M | Italian | Yes | 5.0 | Exons 13 & 14 | 4 | mm |

* See Table II. [‡] Possible duplication of exons 7–12. [§] ND, not done.

Two cell strains showed only abnormal mRNAs. FH 132 showed a 6.2-kb species (Fig. 2 D) and FH 651 a 5.0-kb LDL receptor mRNA (Fig. 2 A). In some RNA samples (FH 61 and 842 in Fig. 2 A and normal in Fig. 2 B), a faint band of ~ 8 kb is seen. We believe that this RNA represents an incompletely spliced nuclear RNA since its amount varies from nondetectable to trace in different preparations of RNA from a single individual.

In an effort to determine which *crm*⁻ individuals harbor the same mutation, the RFLP haplotypes of the chromosomes were analyzed (Table II). Genomic DNA was isolated from fibroblasts and digested separately with multiple restriction enzymes known to reveal 10 RFLPs. The frequency of the least common allele at each RFLP site varies from 5 to 47% in the general American white population, and most individuals from nonconsanguineous matings are heterozygous at more than one of these loci (Leitersdorf, E., et al., manuscript in preparation). The results from the 32 *crm*⁻ FH chromosomes are summarized in Table II. In some instances a deletion in the gene on one or both homologues prevented the ascertainment of certain polymorphic sites (indicated by the asterisks in Table II). 13 of the 16 patients were homozygous at all RFLPs examined, thus allowing an unambiguous assignment of haplotype. These haplotypes are designated *a* through *m* in Tables I and II. Three subjects (FH 26, 132, and 790) were heterozygous at one or more RFLP sites. Although a precise haplotype assignment could not be made in these cases, we gave each of them two letter designations in Tables I and II to indicate that two different haplotypes were present. Using this scheme, we were able to demonstrate the existence among these subjects of 13 distinct LDL receptor haplotypes. Inasmuch as mutations

in genes appear to arise after the formation of RFLP haplotypes (see below), these data suggest the existence of at least 13 separate *crm*⁻ alleles at the LDL receptor locus.

Southern blotting experiments revealed four different gross deletions of the LDL receptor gene among the *crm*⁻ subjects. One deletion, which prevents expression of LDL receptor mRNA, has been described previously at the molecular level (29). This deletion is found in a majority of French Canadians with FH. Another deletion, also associated with an absence of mRNA (Fig. 2), was detected in FH 26, an American who had two different haplotypes (Table II) and was thus a genetic compound. To test whether FH 26 carried the same deletion as that found in the French Canadians, DNA samples from a normal subject, FH 26, her parents, and one of the French Canadian homozygotes (FH 49) were digested with the restriction enzymes Kpn I and Xba I, and then analyzed by Southern blotting with a radioactive probe derived from exon 2 (Fig. 3). In the normal DNA, a fragment of 9 kb was detected (fragment A, Fig. 3), which was derived from an Xba I site in intron 1, and a Kpn I site in intron 2. This same fragment was present in the FH 26 DNA together with an abnormal fragment of ~ 13 kb (fragment C, Fig. 3). As diagramed in Fig. 3, analysis of the previously determined restriction map in this region of the gene (9) together with additional experiments (not shown) suggested that fragment C in the FH 26 DNA was produced by a deletion of ~ 6 kb spanning exon 1 and the Xba I site in intron 1. The 5' end of this fragment was derived from an Xba I site in the 5'-flanking region of the gene, and the 3' end was derived from the Kpn I site in intron 2 (Fig. 3). Digestion of DNA from a homozygous FH French Canadian subject (FH 49) with Xba I and Kpn I gave rise to an abnormal fragment of

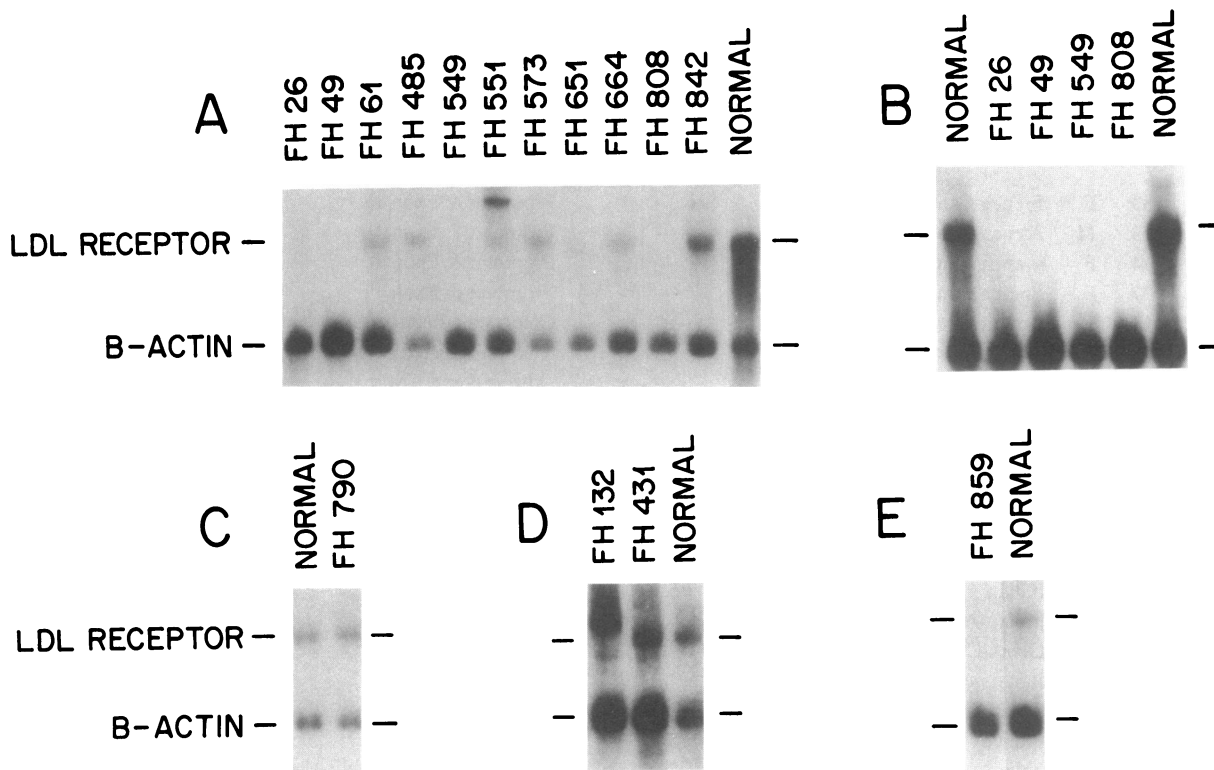

Figure 2. Blotting analysis of RNA isolated from the fibroblasts of 16 FH homozygotes who synthesize no LDL receptors. Total RNA (10 μ g) from the indicated subject was denatured with glyoxal and subjected to electrophoresis in 1.5% agarose gels in 40 mM 3'-(*N*-morpholino)propanesulfonic acid, pH 7.0 at room temperature for 16 h. After capillary transfer to Zeta Probe nylon membranes, baking at 80°C for 75 min, and prehybridization, the membranes were hy-

bridized at 42°C for 16 h with a mixture of three single-stranded ³²P-labeled probes complementary to different regions of the LDL receptor mRNA (17) and one probe complementary to the human β -actin mRNA (38). After hybridization, the filters were washed and used to expose Kodak XAR-5 film at -70°C with DuPont Cronex Lightning Plus intensifying screens. Exposure times varied from 24 to 72 h for the different panels (A-E).

15 kb (fragment B, Fig. 3), which was larger than the abnormal fragment in FH 26. Thus the deletion in FH 26 was different from that found in the French Canadians (29).

Analysis of DNA from the parents of FH 26 confirmed that she was a compound heterozygote who inherited the gene with the 6-kb deletion from her father and a different mutant allele from her mother (Fig. 3). This maternal allele showed no detectable difference from the normal allele in Southern blotting experiments.

As shown in Fig. 4, a third type of deletion was detected by Southern blotting in FH 651, an individual of Italian descent. When DNA from a normal subject and from FH 651 was digested with Xba I and then analyzed with a probe derived from exon 15, two different fragments were visualized. DNA from the normal individual contained a fragment of 12 kb derived from Xba I sites in intron 12 and intron 15, whereas DNA from FH 651 contained a fragment of 8 kb which was derived from these same Xba I sites, but apparently contained an internal 4-kb deletion (Fig. 4). Digestion of the FH 651 DNA with Kpn I and subsequent blotting with an exon 15 probe localized this deletion to a region spanning exons 13 and 14. The FH 651 DNA contained a larger Kpn I fragment of ~ 23 kb as compared with the normal fragment of 9 kb. This abnormal fragment resulted from deletion of the Kpn I site on the 3' side of exon 13. Additional Southern blotting experiments with different restriction enzymes showed that the dele-

tion harbored by FH 651 resembles an FH mutation that was recently cloned by Humphries and his colleagues (30, 31).

Fig. 5 shows the restriction digests of the DNA of FH 132, a compound heterozygote with gross structural alterations of each receptor allele. The results yielded a complex pattern of restriction fragments that was difficult to interpret in a definitive way. Digestion of normal DNA with Eco RV and analysis with an exon 7 probe revealed a fragment of ~ 23 kb. This normal fragment plus a novel DNA band of ~ 5 kb were detected in FH 132 (Fig. 5 A). When the same blot was probed with an exon 1 or exon 2 probe, no abnormal band was visualized (data not shown). Digestion of FH 132 DNA with Eco RI and analysis after blotting with an exon 11 probe revealed a normal fragment of ~ 23 kb and an abnormal fragment of ~ 2 kb (Fig. 5 B). The normal 23-kb band was derived from an Eco RI site in intron 10 and a site in the 3'-flanking region of the gene. Additional blotting experiments (data not shown) using Eco RI and probes derived from exons 13-18 disclosed no abnormal bands.

The presence of a normal fragment plus an abnormal fragment in two widely spaced regions of the FH 132 DNA suggested one of two possibilities: (a) this individual is a compound heterozygote with a different deletion in each of her LDL receptor genes, one at the 5' end of the gene removing exons 1-6 and the other at the 3' end of the gene removing exons 13-18; or (b) FH 132 is a compound heterozygote with a

Table II. Haplotype Analysis of FH Homozygotes with *crm*⁻ Phenotype[§]

| FH homozygote | | Restriction sites | | | | | | | | | | Haplotypes |
|---------------|------------------|-------------------|----------------------|--------------------|----------------------|-----------------------|---------------------------|------------------------|---------------------|----------------|--------------------|------------|
| Number | Ethnic origin | Bsm I 5' FR | Sph I intron 6 | Stu I exon 8 | Ava II exon 13 | Spe I intron 15 | Apa LI-5' intron 15 | Pvu II intron 15 | Nco I exon 18 | Pst I 3' FR | Apa LI-3' 3' FR | |
| 49 | French Canadian | ** | --- | ++ | --- | --- | --- | --- | --- | --- | --- | aa |
| 549 | French Canadian | ** | --- | ++ | --- | --- | --- | --- | --- | --- | --- | aa |
| 808 | French Canadian | ** | --- | ++ | --- | --- | --- | --- | --- | --- | --- | aa |
| 859 | French Canadian | ** | --- | ++ | --- | --- | --- | --- | --- | --- | --- | aa |
| 26 | American | *- | --- | ++ | --- | -+ | -+ | +- | ++ | --- | ++ | bc |
| 132 | Italian-American | -* | -* | + | -* | -* | -* | -* | -* | -* | -* | de |
| 431 | American | ++ | ++ | ++ | ++ | --- | ++ | --- | ++ | ++ | ++ | ff |
| 485 | Colombian | ++ | ++ | ++ | ++ | --- | ++ | --- | ++ | ++ | ++ | ff |
| 664 | American | ++ | ++ | ++ | ++ | --- | ++ | --- | ++ | ++ | ++ | ff |
| 842 | Italian | --- | ++ | ++ | ++ | --- | ++ | --- | --- | ++ | ++ | gg |
| 61 | Italian-American | ++ | --- | ++ | --- | --- | --- | ++ | ++ | --- | ++ | hh |
| 250 | Greek-Cypriot | ++ | --- | ++ | --- | --- | --- | ++ | ++ | --- | ++ | hh |
| 551 | Japanese | ++ | ++ | ++ | --- | ++ | ++ | --- | ++ | --- | ++ | ii |
| 790 | Chinese | +- | ++ | ++ | --- | ++ | ++ | --- | ++ | --- | ++ | jk |
| 573 | French | --- | ++ | ++ | --- | --- | ++ | --- | ++ | ++ | ++ | ll |
| 651 | Italian | ++ | ++ | ++ | ** | ** | ++ | --- | ++ | ++ | ++ | mm |

[§] Haplotype: +, restriction site present; -, restriction site absent; *, restriction site in deleted segment of the gene. The location of each polymorphic site is indicated below the restriction enzyme used to detect the polymorphism. 5' FR, 5'-flanking region; 3' FR, 3'-flanking region.

large deletion in one gene and a complex rearrangement in the other gene. Analysis of RNA favored the latter interpretation. FH 132 cells had a single abnormal RNA of 6.2 kb and no normal-sized mRNA (Fig. 2). The 6.2-kb mRNA hybridized with cDNA probes from both exon 4 and exon 17 (data not shown). If the 6.2-kb transcript originated from one of two alleles with a deletion, it would be expected to hybridize to

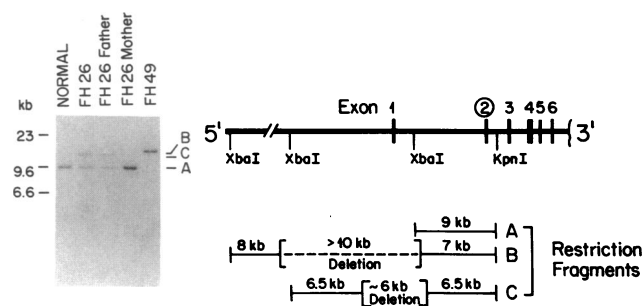

Figure 3. Southern blot analysis of DNA from the family of FH 26. Total genomic DNA (5 μ g) from the indicated individual was digested with Kpn I and Xba I, subjected to electrophoresis in 0.8% agarose, transferred to a nylon membrane, and hybridized to a ³²P-labeled probe derived from exon 2 of the normal LDL receptor gene. After washing as described in Methods, the filter was used to expose Kodak XAR-5 film for 48 h at -70°C in the presence of an intensifying screen. The visualized fragments are designated A, B, and C. Molecular weight markers in kilobases are shown on the left side of the autoradiogram. These were derived from electrophoresis of a Hind III digest of bacteriophage lambda DNA. A Kpn I and Xba I map of the relevant portion of the gene is shown on the right together with an interpretation of the results shown in the autoradiogram. The location of the probe is circled on the map. FH 49 is a French Canadian homozygote.

only one of these probes. Thus, the RNA analysis is most consistent with the 6.2-kb transcript arising from an allele harboring a complex rearrangement, possibly a partial duplication involving exons 7-12. This model implies that the other FH 132 allele is deleted completely or nearly completely in its entirety. This observation is supported by two other lines of evidence: (a) in Southern blots in which probes from exons 1 and 6 were used, the intensity of the normal bands was approximately one-half the intensity that would be expected from the amount of DNA that was loaded, implying that FH 132 had only single copy of these exons (data not shown); and (b) the FH 132 DNA showed only a single band at each of the 10 RFLP sites (Table II), even though this subject would be expected to have two different haplotypes based on the fact that she is a compound heterozygote. The complex rearrangement in the expressed allele of FH 132 probably involves a partial duplication of the gene. Definitive analysis will require cloning and sequencing of the two abnormal alleles.

Discussion

The analysis of fibroblasts from subjects with the homozygous form of FH has revealed at least four broad classes of mutations that disrupt the synthesis, intracellular transport, and binding and internalization functions of the LDL receptor (2, 7). Here, we have characterized at the molecular level one of these classes, namely, the mutations in which the synthesis of immunodetectable receptor protein is abolished (*crm*⁻ alleles). We have used a composite approach employing RNA blot hybridization to determine the presence of receptor mRNA and Southern blot analysis to search for deletions in the gene and to ascertain the RFLP haplotype on which the mutations occur. Among the 132 FH homozygote fibroblast strains that

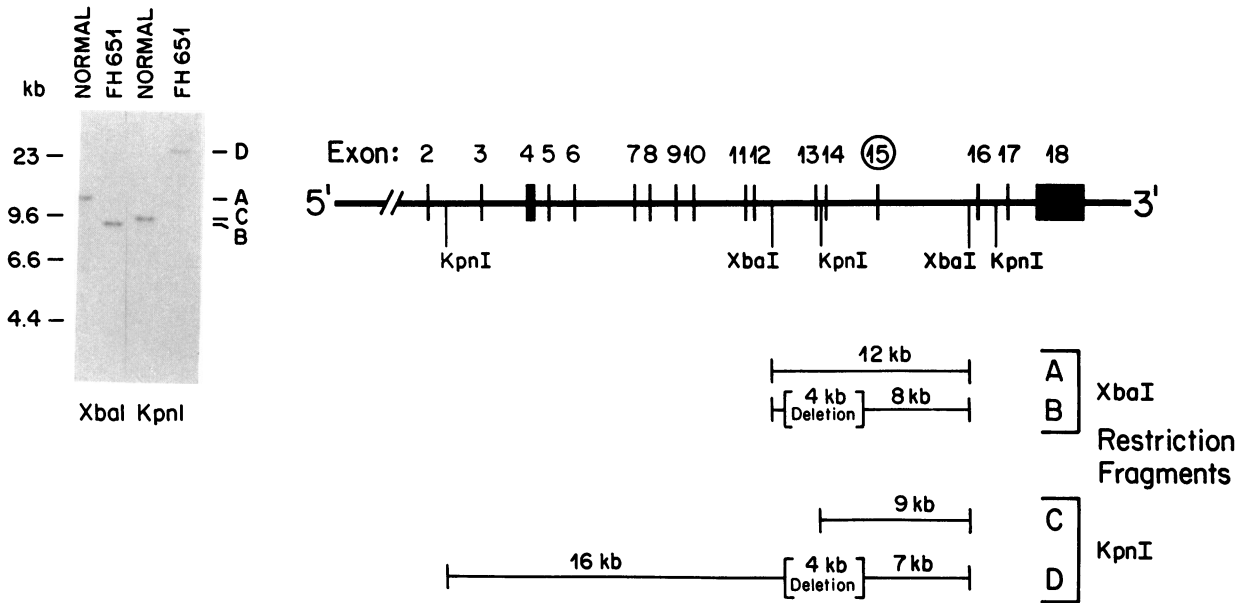

Figure 4. Southern blot analysis of FH 651 DNA. Total genomic DNA (5 μ g), isolated from a normal subject or FH 651, was digested with either Xba I or Kpn I and subjected to Southern blotting as described in the legend to Fig. 3. The probe was derived from exon 15, which is circled in the restriction endonuclease map shown at the

right of the autoradiogram. An interpretation of the four DNA fragments visualized in the experiment (A-D) is shown below the map. The filter was exposed to XAR-5 film for 48 h at -70°C in the presence of an intensifying screen.

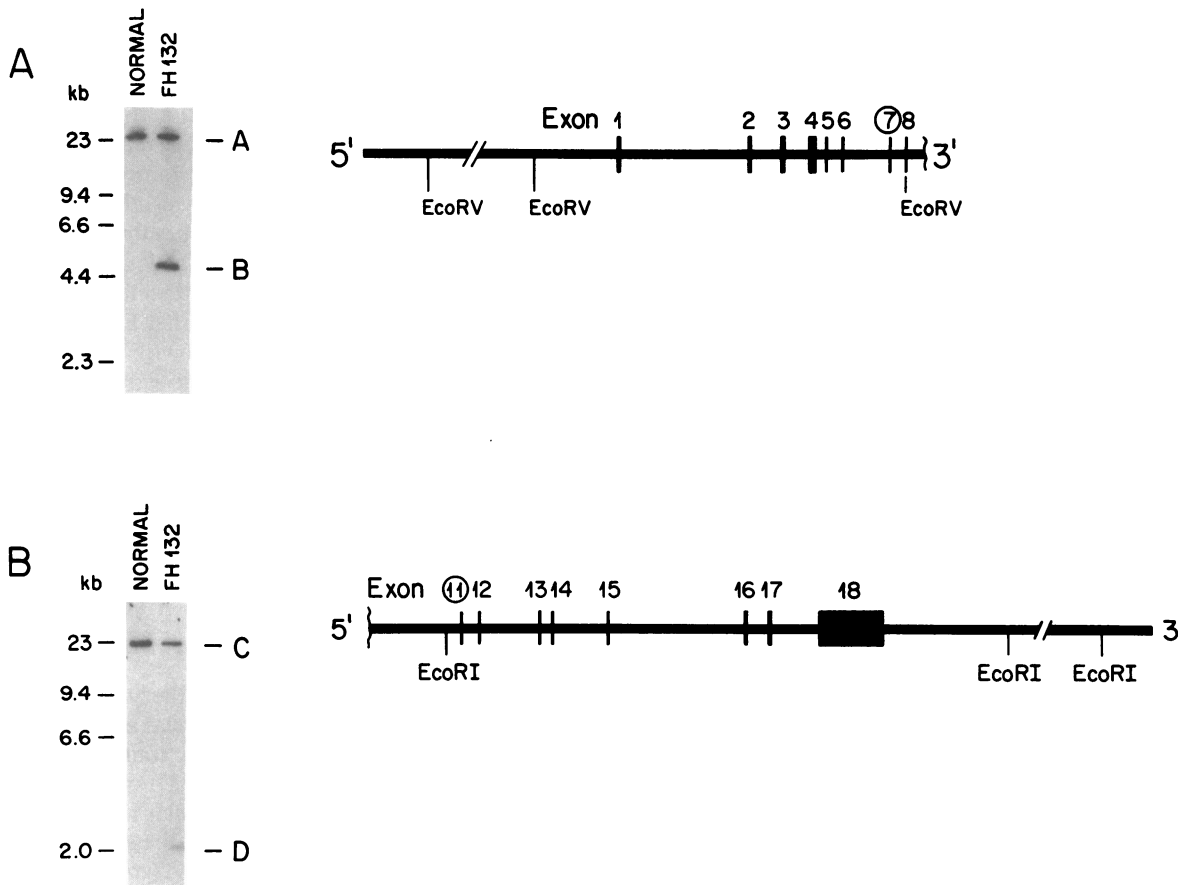

Figure 5. Southern blot analysis of FH 132 DNA. Total genomic DNA (5 μ g) was isolated from FH 132 and a normal subject and analyzed by Southern blotting as described in Fig. 3. FH 132 is a compound heterozygote with two different mutations in the LDL receptor gene. (A) The DNAs were digested with Eco RV and then probed with a radiolabeled fragment derived from exon 7 of the normal

LDL receptor gene (circled in schematic). After washing, the filter was used to expose XAR-5 film for 48 h at -70°C with an intensifying screen. An Eco RV map of the 5' portion of the gene is shown to the right of the autoradiogram. (B) The DNAs were digested with Eco RI and then probed with a radiolabeled fragment derived from exon 11 (circled).

were analyzed, 16 have two crm^- genes. Fibroblast strains from one of these subjects were not available for RNA analysis and so the current studies represent an analysis of the 30 crm^- genes in the remaining 15 patients. The results of this analysis are summarized in Fig. 6.

The current studies were performed with a monoclonal antibody that recognizes the first cysteine-rich repeat in the ligand binding domain of the LDL receptor (32). It is possible that some of the crm^- cell strains that contain mRNA produce an altered LDL receptor protein that lacks the epitope recognized by this antibody. Against this possibility is the previous demonstration that one cell line, FH 664, fails to produce a protein that is recognized by a polyclonal anti-receptor antibody (6). As described below, FH 664 is one of the three patients who is homozygous for the f haplotype and produces a normal-sized mRNA (Table I). Moreover, among the deletion-bearing genes that are $mRNA^+$, none has a deletion that removes the coding region for the epitope recognized by the monoclonal antibody.

The assignment of RFLP haplotypes was made possible by the presence of 10 polymorphic restriction fragment sites in or near the LDL receptor gene. Thirteen of the crm^- subjects were homozygous at all 10 restriction sites (Tables I and II), thus allowing unambiguous assignment of the haplotype of each of these chromosomes without the necessity of studying chromosomes from family members. Homozygosity for RFLPs in these patients suggests that each of them has inherited two copies of the same mutant gene, presumably as a result of common ancestry, even though consanguinity was usually denied.

In taking advantage of the haplotype analysis to classify the mutant alleles, we have based our conclusions on previous analyses of the β -globin gene locus (33) and the phenylalanine hydroxylase locus (34, 35). These studies have shown that the RFLP haplotypes of the chromosomes antedate the mutations in the genes. In general, each mutation occurs upon the background of a different RFLP haplotype. If two mutant genes

have different haplotypes, then it is likely that the two genes bear different mutations, especially if the haplotypes differ at more than one RFLP site.

Using the above criteria, we can first divide the 30 crm^- genes into two classes: those that fail to produce mRNA and those that produce mRNA (Fig. 6). We can then use the deletion analysis and haplotype assignment to estimate the number of different alleles within each class. Eleven of the genes are of the $mRNA^-$ type, and these comprise four different mutant alleles. Three of the four $mRNA^-$ alleles contain deletions that include the promoter, and these account for 10 of the 11 $mRNA^-$ genes. 8 of these 10 genes occurred in homozygous form in individuals of French Canadian descent (Tables I and II). We have previously shown that this mutant allele contains a deletion that removes more than 10 kb of the gene, including the promoter (29). A second promoter deletion was found in subject FH 26, a genetic compound who had two different RFLP haplotypes that were associated with two different $mRNA^-$ alleles (Tables I and II). One of the $mRNA^-$ alleles in FH 26 contained a 6-kb deletion that removed the promoter (Fig. 3). The other allele in FH 26 contained no visible deletion and is discussed below. A third promoter deletion occurred in FH 132, another genetic compound. The size of the deleted region cannot be conclusively determined from the available data, but appears to involve most of the gene, including the promoter region.

Among the four $mRNA^-$ alleles, only one was of the non-deletion type (Fig. 6). This was the second allele present in FH 26 (Fig. 3). All regions of this gene appeared normal in Southern blots. Moreover, in experiments using a gene-amplification technique (36), we found that the sequence of the immediate 5' flanking region of the gene was normal (Russell, D. W., unpublished observations). This sequence contains all of the signals that are known to be necessary for transcription (37). The $mRNA^-$ phenotype from this allele must be attributable either to improper processing of the mRNA or to some instability in its structure.

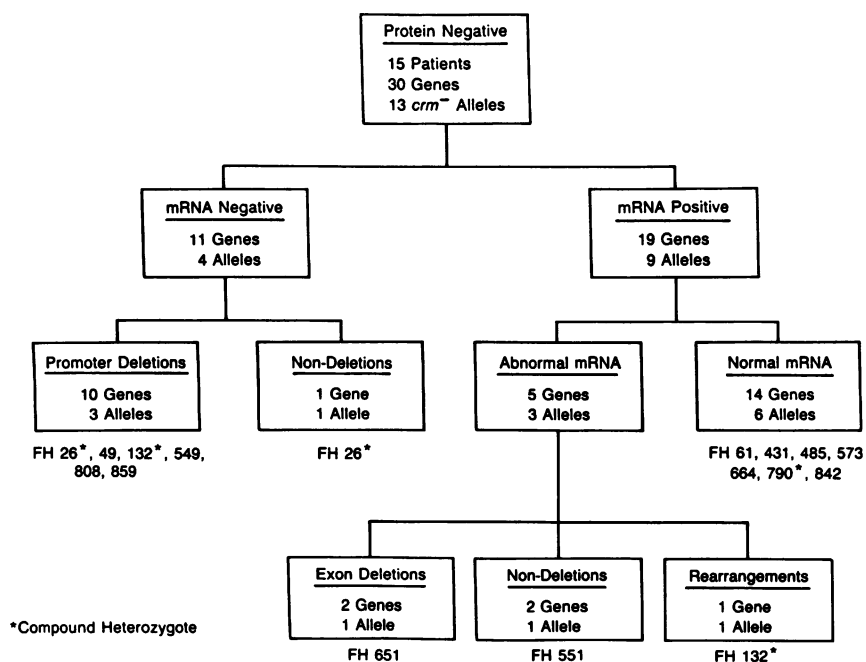

Figure 6. Genetic analysis of 15 FH homozygotes with the crm^- phenotype. These subjects were obtained from an initial screen of 132 FH homozygotes (see text). 16 crm^- cell strains were identified. One FH homozygote with a crm^- phenotype (FH 550; see Table I) was omitted from this analysis because measurements of receptor mRNA could not be obtained, owing to a lack of availability of cultured fibroblasts.

All of the FH homozygotes in the mRNA⁻ category who were homozygous for a visible deletion were also homozygous for their RFLP haplotypes. For example, the French Canadians all had the aa haplotypes (Table II). In contrast, the FH homozygote who had two different mutations (FH 26) was heterozygous for her RFLP haplotypes. FH 132, a compound heterozygote, appeared to be homozygous at each RFLP site, most likely because one of her alleles has a large deletion, as discussed above. All of the haplotypes in these latter two patients were different from each other, and they also differed from the haplotypes in the French Canadian individuals (Table II). These data support the notion that each mutation in the LDL receptor gene arose on the background of a specific RFLP haplotype and that the haplotype antedated the mutation.

Among the 30 genes with a crm⁻ phenotype, 19 were mRNA⁺ (Fig. 6). These 19 genes could be subdivided into nine alleles, three of which produced mRNAs of abnormal size. One of these latter alleles occurred in homozygous form in FH 651, who synthesized an mRNA of 5.0 kb as a consequence of a deletion that removed exon 13 and 14. Inasmuch as exons 13 and 14 account for ~ 300 bp of the normal 5.3-kb LDL receptor mRNA (9), the size of the FH 651 mRNA (5.0 kb) is consistent with the splicing of exon 12 to exon 15. Such an event would shift the translation reading frame of the deleted mRNA and result in a truncated protein that terminates after 48 bp of the exon 15 sequence (8, 9, 31). We have previously characterized a mutation in a subject known as FH 381, in which a deletion of 5 kb joined exon 13 to a portion of intron 15 (14). Although a shortened mRNA was present in FH 381, we were unable to detect any truncated LDL receptor protein within the cells or in the culture medium, which suggests that this protein was rapidly degraded. (FH 381 is not included in the current analysis because she is the heterozygous mother of a compound heterozygote in whom the second mutant allele produced an immunoprecipitable protein [13]). A similar explanation of protein instability can be invoked to explain the crm⁻ phenotype of FH 651.

The second RNA⁺ allele occurred in FH 132, who produced an mRNA of 6.2 kb that was derived from a gene harboring a complex rearrangement in one of the two alleles. The third RNA⁺ allele occurred in patient FH 551. This individual, who is homozygous at all ten RFLP sites, produced both an abnormally sized receptor mRNA (major product) and a normally sized mRNA (minor product). The genesis of the abnormal 8.4-kb mRNA in this homozygous subject is most readily attributable to a splicing defect. Southern blotting of genomic DNA revealed no alterations in gene structure. These results suggest that a small insertion, deletion, or point mutation may have altered a splice donor or acceptor site, giving rise primarily to an elongated mRNA. The latter mRNA could encode a very small protein or an unstable protein, thus explaining the crm⁻ phenotype.

The remaining six RNA⁺ alleles analyzed in this study synthesized an LDL receptor mRNA that was apparently normal in size (Fig. 6). By Southern blotting we were unable to detect any gross alterations in these genes, and thus we cannot address the underlying cause of the crm⁻ phenotype. It is likely, however, that many of these mutations result in premature stop codons. Three of these patients (FH 431, 485, and 664) are homozygous for the same RFLP haplotype (designated f in Tables I and II). Two are Americans and one is from

Colombia. The frequency of the f haplotype in white Americans is ~ 30% (Leitersdorf, E., et al., manuscript in preparation). It is possible that these three patients have the same mutation and that this mutation is a fairly common one among FH patients. However, since the f haplotype is common, it is also possible that these three patients have different mutations that have all occurred on the same haplotype background.

Acknowledgments

We thank Mark Lehrman for valuable suggestions. Shellie Craig, Daphne Davis, and Gloria Brunschede provided excellent technical assistance. Edith Womack, Lavon Sanders, and Deborah Darrie provided invaluable assistance in culturing the fibroblast cell strains.

This work was supported by grants from the National Institutes of Health (HL 20948) and the Robert A. Welch Foundation (I-971). H. H. Hobbs is supported by the Syntex Scholar Program. E. Leitersdorf is the recipient of a fellowship from the Fogarty International Center of the National Institutes of Health Research (1F-05-TW03742). D. W. Russell is the recipient of a National Institutes of Health Research Career Development Award (HL 01287).

References

1. Goldstein, J. L., and M. S. Brown. 1983. Familial hypercholesterolemia. In *The Metabolic Basis of Inherited Disease*. 5th ed. J. B. Stanbury, J. B. Wyngaarden, D. S. Fredrickson, J. L. Goldstein, and M. S. Brown, editors. McGraw-Hill Book Co., New York. 672-712.
2. Brown, M. S., and J. L. Goldstein. 1986. A receptor-mediated pathway for cholesterol homeostasis. *Science (Wash. DC)*. 232:34-47.
3. Schneider, W. J., U. Beisiegel, J. L. Goldstein, and M. S. Brown. 1982. Purification of the low density lipoprotein receptor, an acidic glycoprotein of 164,000 molecular weight. *J. Biol. Chem.* 257:2664-2673.
4. Beisiegel, U., W. J. Schneider, J. L. Goldstein, R. G. W. Anderson, and M. S. Brown. 1981. Monoclonal antibodies to the low density lipoprotein receptor as probes for study of receptor-mediated endocytosis and the genetics of familial hypercholesterolemia. *J. Biol. Chem.* 256:11923-11931.
5. Tolleshaug, H., J. L. Goldstein, W. J. Schneider, and M. S. Brown. 1982. Posttranslational processing of the LDL receptor and its genetic disruption in familial hypercholesterolemia. *Cell*. 30:715-724.
6. Tolleshaug, H., K. K. Hobgood, M. S. Brown, and J. L. Goldstein. 1983. The LDL receptor locus in familial hypercholesterolemia: multiple mutations disrupting the transport and processing of a membrane receptor. *Cell*. 32:941-951.
7. Russell, D. W., M. A. Lehrman, T. C. Südhof, T. Yamamoto, C. G. Davis, H. H. Hobbs, M. S. Brown, and J. L. Goldstein. 1987. The LDL receptor in familial hypercholesterolemia: use of human mutations to dissect a membrane protein. *Cold Spring Harbor Symp. Quant. Biol.* 51:811-819.
8. Yamamoto, T., C. G. Davis, M. S. Brown, W. J. Schneider, M. L. Casey, J. L. Goldstein, and D. W. Russell. 1984. The human LDL receptor: a cysteine-rich protein with multiple Alu sequences in its mRNA. *Cell*. 39:27-38.
9. Südhof, T. C., J. L. Goldstein, M. S. Brown, and D. W. Russell. 1985. The LDL receptor gene: a mosaic of exons shared with different proteins. *Science (Wash. DC)*. 228:815-822.
10. Lindgren, V., K. L. Luskey, D. W. Russell, and U. Francke. 1985. Human genes involved in cholesterol metabolism: chromosomal mapping of the loci for the low density lipoprotein receptor and 3-hydroxy-3-methylglutaryl-coenzyme A reductase with cDNA probes. *Proc. Natl. Acad. Sci. USA*. 82:8567-8571.
11. Lehrman, M. A., W. J. Schneider, T. C. Südhof, M. S. Brown,

- J. L. Goldstein, and D. W. Russell. 1985. Mutation in LDL receptor: Alu-Alu recombination deletes exons encoding transmembrane and cytoplasmic domains. *Science (Wash. DC)*. 227:140-146.
12. Lehrman, M. A., J. L. Goldstein, M. S. Brown, D. W. Russell, and W. J. Schneider. 1985. Internalization-defective LDL receptors produced by genes with nonsense and frameshift mutations that truncate the cytoplasmic domain. *Cell*. 41:735-743.
13. Davis, C. G., M. A. Lehrman, D. W. Russell, R. G. W. Anderson, M. S. Brown, and J. L. Goldstein. 1986. The J. D. mutation in familial hypercholesterolemia: substitution of cysteine for tyrosine in cytoplasmic domain impedes internalization of LDL receptors. *Cell*. 45:15-24.
14. Lehrman, M. A., D. W. Russell, J. L. Goldstein, and M. S. Brown. 1986. Exon-Alu recombination deletes 5 kilobases from low density lipoprotein receptor gene, producing null phenotype in familial hypercholesterolemia. *Proc. Natl. Acad. Sci. USA*. 83:3679-3683.
15. Hobbs, H. H., M. S. Brown, J. L. Goldstein, and D. W. Russell. 1986. Deletion of exon encoding cysteine-rich repeat of LDL receptor alters its binding specificity in a subject with familial hypercholesterolemia. *J. Biol. Chem.* 261:13114-13120.
16. Lehrman, M. A., W. J. Schneider, M. S. Brown, C. G. Davis, A. Elhammer, D. W. Russell, and J. L. Goldstein. 1987. The Lebanese allele at the LDL receptor locus: nonsense mutation produces truncated receptor that is retained in endoplasmic reticulum. *J. Biol. Chem.* 262:401-410.
17. Lehrman, M. A., D. W. Russell, J. L. Goldstein, and M. S. Brown. 1987. Alu-Alu recombination deletes splice acceptor sites and produces secreted LDL receptor in a subject with familial hypercholesterolemia. *J. Biol. Chem.* 262:3354-3361.
18. Lehrman, M. A., J. L. Goldstein, D. W. Russell, and M. S. Brown. 1987. Duplication of seven exons in LDL receptor gene caused by Alu-Alu recombination in a subject with familial hypercholesterolemia. *Cell*. 48:827-835.
19. Goldstein, J. L., S. K. Basu, and M. S. Brown. 1983. Receptor-mediated endocytosis of LDL in cultured cells. *Methods Enzymol.* 98:241-260.
20. Labarca, C., and K. Paigen. 1980. A simple, rapid, and sensitive DNA assay procedure. *Anal. Biochem.* 102:344-352.
21. Church, G. M., and W. Gilbert. 1984. Genomic sequencing. *Proc. Natl. Acad. Sci. USA*. 81:1991-1995.
22. Kotze, M. J., A. E. Retief, P. A. Brink, and H. F. H. Weich. 1986. A DNA polymorphism in the human low-density lipoprotein receptor gene. *S. Afr. Med. J.* 70:77-79.
23. Hobbs, H. H., M. A. Lehrman, T. Yamamoto, and D. W. Russell. 1985. Polymorphism and evolution of *Alu* sequences in the human low density lipoprotein receptor gene. *Proc. Natl. Acad. Sci. USA*. 82:7651-7655.
24. Humphries, S. E., A. M. Kessling, B. Horsthemke, J. A. Donald, M. Seed, N. Jowett, M. Holm, D. J. Galton, V. Wynn, and R. Williamson. 1985. A common DNA polymorphism of the low-density lipoprotein (LDL) receptor gene and its use in diagnosis. *Lancet*. i:1003-1005.
25. Hobbs, H. H., V. Esser, and D. W. Russell. 1987. A val polymorphism in the human LDL receptor gene. *Nucleic Acids Res.* 15:379.
26. Leitersdorf, E., and H. H. Hobbs. 1987. Human LDL receptor gene: two ApaLI RFLPs. *Nucleic Acids Res.* 15:2782.
27. Funke, H., J. Klug, P. Frossard, R. Coleman, and G. Assmann. 1986. Pst I RFLP close to the LDL receptor gene. *Nucleic Acids Res.* 14:7820.
28. Kotze, M. J., E. Langenhoven, E. Dietzsch, and A. E. Retief. 1987. A RFLP associated with the low-density lipoprotein receptor gene (LDLR). *Nucleic Acids Res.* 15:376.
29. Hobbs, H. H., M. S. Brown, D. W. Russell, J. Davignon, and J. L. Goldstein. 1987. Deletion in LDL receptor gene occurs in majority of French Canadians with familial hypercholesterolemia. *N. Engl. J. Med.* 317:734-737.
30. Horsthemke, B., A. M. Kessling, M. Seed, V. Wynn, R. Williamson, and S. E. Humphries. 1985. Identification of a deletion in the low density lipoprotein (LDL) receptor gene in a patient with familial hypercholesterolaemia. *Hum. Genet.* 71:75-78.
31. Horsthemke, B., U. Beisiegel, A. Dunning, J. R. Havvinga, R. Williamson, and S. Humphries. 1987. Unequal crossing-over between two alu-repetitive DNA sequences in the low-density-lipoprotein-receptor gene. A possible mechanism for the defect in a patient with familial hypercholesterolaemia. *Eur. J. Biochem.* 164:77-81.
32. van Driel, I. R., J. L. Goldstein, T. C. Südhof, and M. S. Brown. 1987. First cysteine-rich repeat in ligand-binding domain of low density lipoprotein receptor binds Ca²⁺ and monoclonal antibodies, but not lipoproteins. *J. Biol. Chem.* 262:17443-17449.
33. Orkin, S. H., and H. H. Kazazian, Jr. 1984. The mutation and polymorphism of the human β -globin gene and its surrounding DNA. *Annu. Rev. Genet.* 18:131-171.
34. DiLella, A. G., J. Marvit, K. Brayton, and S. L. C. Woo. 1987. An amino-acid substitution involved in phenylketonuria is in linkage disequilibrium with DNA haplotype 2. *Nature (Lond.)*. 327:333-336.
35. DiLella, A. G., J. Marvit, A. S. Lidsky, F. Guttler, and S. L. C. Woo. 1986. Tight linkage between a splicing mutation and a specific DNA haplotype in phenylketonuria. *Nature (Lond.)*. 322:799-805.
36. Saiki, R. K., S. Scharf, F. Faloona, K. B. Mullis, G. T. Horn, H. A. Erlich, and N. Arnheim. 1985. Enzymatic amplification of β -globin genomic sequences and restriction site analysis for diagnosis of sickle cell anemia. *Science (Wash. DC)*. 230:1350-1354.
37. Südhof, T. C., D. R. Van Der Westhuyzen, J. L. Goldstein, M. S. Brown, and D. W. Russell. 1987. Three direct repeats and a TATA-like sequence are required for regulated expression of the human LDL receptor gene. *J. Biol. Chem.* 262:10773-10779.
38. Ma, P. T. S., G. Gil, T. C. Südhof, D. W. Bilheimer, J. L. Goldstein, and M. S. Brown. 1986. Mevinolin, an inhibitor of cholesterol synthesis, induces mRNA for low density lipoprotein receptor in livers of hamsters and rabbits. *Proc. Natl. Acad. Sci. USA*. 83:8370-8374.