

ARTICLE

Germline mutations in *BRCA1*, *BRCA2*, *CHEK2* and *TP53* in patients at high-risk for HBOC: characterizing a Northeast Brazilian Population

Gabriela ES Felix^{1,2}, Camila Abe-Sandes¹, Taísa MB Machado-Lopes¹, Thaís F Bomfim¹, Rodrigo Santa Cruz Guindalini^{1,3}, Vanessa Catarine SAR Santos¹, Lorena Meyer¹, Polyanna C Oliveira^{1,2}, João Cláudio Neiva¹, Roberto Meyer¹, Maura Romeo¹, Maria Betânia Toralles¹, Ivana Nascimento¹ and Kiyoko Abe-Sandes^{1,2}

Considering the importance of *BRCA1*, *BRCA2*, *CHEK2* and *TP53* in the development of hereditary early-onset breast and ovarian cancer and that the genetic susceptibility profile of the Northeast population from Brazil has never been analyzed, this study aimed to verify the frequency of mutations of clinical significance in these genes in high-risk hereditary breast and ovarian cancer (HBOC) syndrome patients from that region. DNA samples from 106 high-risk unrelated patients mostly from Bahia, the biggest state in the Northeast region, were analyzed. These patients underwent full *BRCA1* gene sequencing, screening for common founder mutations in the *BRCA2*, *CHEK2* and *TP53* genes and genetic ancestry analysis with nine ancestry informative markers. The positive results were confirmed by two sequencing reactions. Three mutations of clinical significance were found: *BRCA1* p.R71G (4.71%), 3450del4 (3.77%) and *TP53* p.R337H (0.94%). The genetic ancestry analysis showed a high European ancestry contribution (62.2%) as well as considerable African (31.2%) and Amerindian (6.6%) ancestry contributions ($r^2 = 0.991$); this degree of heterogeneity was also significant in the population structure analysis ($r = 0.604$). This population is highly admixed with a different spectrum of genetic susceptibility, with the Galician founder mutation *BRCA1* p.R71G accounting for 50% of all identified mutations in high-risk HBOC patients. *TP53* p.R337H was also significantly frequent; thus, the combined screening of *BRCA1/2* and *TP53* should be offered to high-risk HBOC patients from Northeast Brazil.

Human Genome Variation (2014) 1, 14012; doi:10.1038/hgv.2014.12; published online 16 October 2014

INTRODUCTION

Breast and ovarian cancers are among the most common cancers in developed and developing countries.¹ Approximately 5–10% of familial cases are due to germline mutations in susceptibility genes, such as *BRCA1*, *BRCA2*, *CHEK2* and *TP53*. These susceptibility genes have key roles in cell cycle control, apoptosis and DNA repair.^{2,3}

Mutations in the *BRCA1* and *BRCA2* genes are associated with the hereditary breast and ovarian cancer (HBOC) syndrome. Patients who have HBOC syndrome have a personal and family history of cancer mainly in the following organs: breast, ovarian, prostate and pancreas.² In contrast, mutations in the *CHEK2* and *TP53* genes are also associated with breast and ovarian cancers, as well as with other cancers related to the Li–Fraumeni Syndrome and Li–Fraumeni-like syndrome.^{4,5}

Many studies have demonstrated that mutations in these susceptibility genes could result in early-onset carcinoma as well as in a worse prognosis; therefore, it is important to use genetic testing to identify these deleterious mutations, so that risk-reducing and risk-prevention strategies can be applied.^{6,7}

In previously characterized populations, it is easy to verify the genetic susceptibility of high-risk individuals, because some germline mutations have founder effects, such as the *BRCA1* c.66_67delAG and c.5266dupC mutations and *BRCA2* c.5946_5946delT in the

Ashkenazi population; *BRCA2* c.156_157insAlu in Portugal; *BRCA2* 999del5 in Iceland; *CHEK2* c.1100 in European populations; and *TP53* p.R337H in Southern Brazil.^{8–13}

Thus, knowing that ethnic differences in cancer incidence and mortality are the results of genetic and epidemiological risk factor interactions, it is crucial to characterize a population which will allow for a more accurate risk assessment and proper genetic counseling for the individuals.^{14,15}

The Brazilian population is one of the most heterogeneous in the world. Many populations have contributed to it, mainly Portuguese, African and Amerindian. However, other European populations, such as the Spanish and Italian, have also contributed to its genetic diversity.¹⁶ As the pattern of admixture in Brazil varies according to the region^{17–21} and no study has been performed with the population from the Northeast region of Brazil, our aim was to verify the frequency of mutations of clinical significance in *BRCA1*, *BRCA2*, *CHEK2* and *TP53* in 106 patients at high risk for HBOC from the Northeast region of Brazil.

MATERIALS AND METHODS

Study population

A total of 106 unrelated Brazilian patients at high risk for HBOC who were referred to the Genetics Clinic of the Hospital Universitário Edgar Santos

¹Laboratório de Imunologia e Biologia Molecular, Instituto de Ciências da Saúde, Universidade Federal da Bahia, Salvador, Brazil; ²Laboratório Avançado de Saúde Pública, Centro de Pesquisas Gonçalo Moniz, Fundação Oswaldo Cruz, Salvador, Brazil and ³Departamento de Radiologia e Oncologia, Faculdade de Medicina da Universidade de São Paulo, São Paulo, Brazil.

Correspondence: GES Felix (gesfelix@yahoo.com.br) or I Nascimento (ivanasci@gmail.com) or K Abe-Sandes (kabesandes@yahoo.com)

Received 27 May 2014; revised 11 July 2014; accepted 31 July 2014

from Universidade Federal da Bahia between 2008 and 2013 were included in the study. The research was approved by the Research Ethics Committee of the institutions that were involved and all of the patients provided informed consent.

During genetic counseling, clinical and epidemiologic data were obtained, and genetic testing was offered to affected individuals who met at least one of the following criteria: (a) two or more family members affected by breast cancer; (b) one family member affected by breast cancer and another affected by ovarian cancer; (c) three or more family members affected by breast or ovarian cancer, with at least one affected with ovarian cancer; (d) breast cancer diagnosed before 45yr of age; (e) ovarian cancer diagnosed before 50yr of age; (f) bilateral breast cancer; (g) male breast cancer at any age; and (h) cancer in multiple organs including breast cancer. The patients' available relatives were also analyzed.

Genotyping susceptibility genes

DNA was extracted from peripheral blood using the Genra Puregene Blood kit (QIAGEN, Hilden, Germany) or the AxyPrep Blood genomic DNA Miniprep kit (Axygen Biosciences, Union City, CA, USA). The screening for mutations in *BRCA1* was performed in two steps: (a) polymerase chain reaction (PCR) of each exon followed by single-strand conformation polymorphism analysis and electrophoresis of denatured DNA as previously described²² and (b) then all of the PCR fragments that presented a different migration pattern on the gel were analyzed by direct sequencing in an ABI PRISM 3130xl genetic analyzer (Applied BioSystems, Foster City, CA USA) using the BigDye™ terminator sequencing kit (Applied BioSystems) as recommend by the manufacturer. The primers used as well as the PCR cycling conditions are shown in Supplementary Table 1.

The initial screening for the mutations *BRCA2* (c.5946_5946delT and c.156_157insAlu), *CHEK2* (c.1100delC, c.444+1G>A and p.I157T) and *TP53* (p.R337H) was performed by AS-PCR followed by electrophoresis in agarose gels (2%) or PCR/RFLP, which consisted of the following steps: (a) PCR reaction, (b) verification of amplification by electrophoresis in agarose gels (1.5%), (c) digestion with the appropriate restriction enzyme and (d) scoring other electrophoreses in agarose gels (2.5%).

The primers and PCR cycling were based on Struwing et al.,⁸ Machado et al.,⁹ Bayram et al.²³ and Custodio et al.²⁴ (Supplementary Table 2). All of the RFLP reactions used enzymes reagents of New England Biolabs (New England Biolabs, Beverly, MA, USA) and were performed according to this manufacturer.

Each PCR reaction contained 0.25 μM each primer, 0.5 mM dNTPs, 10 mM Tris-HCl (pH 8.9), 50 mM KCl, 1.5 or 2.0 mM MgCl₂, 1 U Taq DNA polymerase (Invitrogen, Carlsbad, CA, USA), 25 ng genomic DNA and UltraPure DNase/RNase-Free Distilled Water (Invitrogen) up to 25 μl. Except in the PCR reaction for *TP53*'s mutation, Go Taq Flexi DNA polymerase was used (Promega, Madison, WI, USA).

The positive results were verified by two sequencing reactions. For the genotyping control, 10% of the negative samples were randomly selected and sequenced. The PCR reactions of the *BRCA2* c.156_157insAlu were run with a positive control. The gene reference sequences were NG_005905.2, NG_012772.3, NG_008150.1 and NG_017013.2, which are available in GenBank (NCBI, NIH, USA). The sequences were analyzed using the CLC Bio sequence viewer version 6.8.1 (a QIAGEN Company) and BioEdit version 7.1.9 (Ibis Biosciences, Carlsbad, CA, USA) or FinchTV 1.4.0 (Geospiza, Seattle, WA, USA).

Genetic ancestry analysis

A micro-panel of nine ancestry informative markers was used to estimate the genetic ancestry: *APO*, *AT3-I/D*, *CKMM*, *FY-NULL*, *GC*1S*, *GC*1F*, *LPL*, *PV92* and *SB19.3*. These ancestry informative markers were genotyped as described above by (a) PCR followed by electrophoresis, (b) PCR/RFLP, or (c) real-time PCR as described by Parra et al.²⁵ and Shriver et al.²⁶

The contents of the PCR reaction were as described above, except for the real-time PCR reactions, which used TaqMan SNP genotyping assays (Applied BioSystems) as recommended by the manufacturer and were monitored in ABI Prism 7700 Sequence Detection Systems (Applied Biosystems).

The restriction enzymes were also from New England Biolabs (New England Biolabs). The primers, enzymes, probes and PCR conditions are described in Supplementary Table 3.

Statistical analysis

The descriptive analyses were performed in Epi Info version 7. GENETOP 1.2²⁷ and ADMIX 95²⁸ were used to verify the allelic frequencies and estimate the genetic ancestry. The population structure was analyzed in STRUCTURE v.2.3.4²⁹ with 10,000 for the burn-in period interactions, 10,000 additional interactions and admixture option with the LOCPRIOR model and a *K* value from 1 to 3. The genotypes of the African (Nigerian), Amerindian and European (German and Spanish) populations were kindly provided by Dr Mark Shriver from Penn State University.

RESULTS

All of the patients were female, and most of the patients had cancer before 50 years of age, with a mean age at diagnosis of 43.06 years (SD = ± 10.67). The majority of the cases were breast cancer (91.4%), followed by ovarian cancer (4.7%) (Table 1). Among the breast cancer cases, the most common histological type was the invasive ductal carcinoma (IDC) at 69.30% (70/101), and among the ovarian cancer cases, the most common was serous adenocarcinoma, at 77.77% (7/9).

In addition to the personal cancer history, most of these women also had a family history (83.02%, Table 1), and the frequency of the cancers associated with HBOC (breast cancer, ovarian cancer, prostate cancer and pancreatic cancer) was significant among the first (81.82%)-, second (87.83%)- and third (78.71%)-degree relatives.

Regarding other risk factors, such as the use of oral contraceptives, parity and age at menarche, a significant percentage of the study population had used oral contraceptives for more than 5 years (64.15%) or also had children (76.42%), and the mean age at menarche was 12.89 years (SD = ± 1.63). Another risk factor that was analyzed was the smoking status, but a considerable portion of the subjects were nonsmokers (64.15%) (Table 1).

Knowing that the Brazilian population is composed of at least three ancestral population groups, a trihybrid admixture model was estimated in ADMIX 95, which showed a high European ancestry contribution 62.20% (s.e. = 0.034) and considerable African and Amerindian ancestry contributions, 31.20% (s.e. = 0.011) and 6.60% (s.e. = 0.036), respectively. This analysis was statistically significant ($r^2 = 0.991$), and the study population fit the Hardy-Weinberg Equilibrium ($P < 0.005$).

In addition, the population stratification analysis in STRUCTURE was also significant for $K=3$ ($r=0.604$); the bar plot in Figure 1 (left) shows the genetic admixture proportions of the Brazilian study population compared with the African, Amerindian and European populations based on the ancestry informative markers panel. The triangle plot in Figure 1 (right) demonstrates the distribution of the subjects according their genetic admixture and population of origin, in which is observed the heterogeneity degree of the study population clustered between the European and African populations. The average distances (expected heterozygosity) between individuals in the same cluster was greater in cluster 3 (0.319), in which the study population was more closely clustered than was that in cluster 1 (0.262) and cluster 2 (0.256), in which the African and Amerindian populations clustered (see triangle plot, Figure 1). The subjects also exhibited a distinct pattern in the assessment of self-reported race/color; most of the subjects self-reported as mulatto (40.57%), followed by white (34.91%) and black (20.75%). Almost all of the subjects were from the State of Bahia (83.02%), but there were also subjects from other regions of Brazil (15.09%) (Table 1).

Ten unrelated patients were identified with mutations of clinical significance; the most frequent mutation was *BRCA1* c.211A>G^{rs80357382} (4.71%; 5/10), followed by *BRCA1* c.3331_3334delCAAG^{rs80357777} (3.77%; 4/10) and *TP53* p. R337H^{rs121912664} (0.94%; 1/10). Six of these patients were from the countryside regions of the State of Bahia and four were from Salvador, the capital of Bahia. The clinic and pathological

Table 1. Baseline characteristics of the 106 patients analyzed

Characteristic	%	N
Cancer		
Breast	91.51	97
Ovarian	4.72	5
Breast and ovarian	3.77	4
Age at diagnostic^a		
< 50yrs	77.36	82
≥50yrs	22.64	24
Tumor location		
Unilateral	69.81	74
Bilateral	4.72	5
Missing	25.47	27
Origin		
Salvador, BA	30.19	32
Countryside of BA	52.83	56
Other regions of Brazil	15.09	16
Missing	1.89	2
Self-reported race/color		
White	34.91	37
Mulatto	40.57	43
Black	20.75	22
Others	3.77	4
Family history		
Without family history	16.98	18
Only 1st relatives	11.32	12
1st and 2nd relatives	17.92	19
1st and 3rd relatives	3.77	4
Only 2nd relatives	9.43	9
2nd and 3rd relatives	12.26	13
Only 3rd relatives	8.49	9
1st, 2nd and 3rd relatives	19.81	21
Oral contraceptive^b		
Yes	64.15	68
No	16.98	18
Missing	18.87	20
Parity		
Any birth	23.58	25
1–2 births	44.34	47
3–4 births	16.04	17
5 births	1.89	2
Missing	14.15	15
Smoker^c		
Yes	16.04	17
No	64.15	68
Missing	19.81	21

^aAge at diagnostic of the first cancer. ^bOral contraceptive for more than 5 years. ^cIt was considered as smoker the use of tobacco for more than 1 year.

characteristics of the mutation carriers are described in Table 2, and Figure 2 shows the sequencing fragments of the identified mutations.

All of the mutation carriers had a family history of breast and ovarian cancer involving first-, second- and/or third-degree relatives (80.00%), except for two carriers who had no suggestive family history of any cancer (patients #21.1 and #106.1, Table 2). The pedigrees of three subjects who are carriers for each mutation are shown in the Figure 3, which presents the segregation of these mutations among first- and second-degree relatives, except for

the *TP53* p.R337H mutation carrier (Patient #97.1) for whom no family members were available for testing.

No patient with the Galician founder mutation (*BRCA1* c.211A>G) reported a Spanish ancestry contribution in their families, whereas among the patients with the *BRCA1* c.3331_3334delCAAG (3450del4), three reported a Portuguese and/or French ancestry contribution and the fourth patient reported an Italian ancestry contribution. The *TP53* p.R337H mutation's carrier did not report her ancestry contribution. Table 2 presents the estimated genetic ancestry proportion for each mutation carrier, which was similarly estimated for the study population as a whole as described above.

DISCUSSION

Here, 106 unrelated high-risk subjects for HBOC from Northeast Brazil, a population that until now was uncharacterized, were analyzed. In this population, two mutations of clinical significance were found in *BRCA1*, 3450del4 and p.R71G (8.49%) and one in *TP53*, p.R337H (0.94%). These mutations were associated with aggressive clinic-pathological characteristics; most of the subjects had IDC and triple-negative tumors, and a family history of cancer involving first-, second- and/or third-degree relatives (Table 2 and Figure 3). Only two mutation carriers did not have a family history of any cancer, but both of these carriers had early-onset breast cancer (patients #21.1 and #106.1, Table 2).

The 3450del4 mutation has been described in many populations worldwide.^{30–34} In South America, this mutation has been described among patients with HBOC from other regions of Brazil^{33,34} and among patients with ovarian cancer from Colombia.³¹ In fact, in Colombia, 3450del4 was the only mutation of clinical significance, suggesting a founder effect. Here, this mutation also had a significant frequency among the patients from Northeast Brazil, with a frequency higher (3.77%) than that previously observed in the others regions of Brazil, at 0.16%³³ and 2.12%.³⁴

The other mutation that was found in this study, *BRCA1* p.R71G, which accounted for 50% of the mutations identified, is a Galician founder mutation that was first described by Vega *et al.*³⁵ Based on the mtDNA analysis, the Galician population is very homogeneous, with traits of a Culdesac population with a striking similarity to the Basque population owing to its geographic location and cultural barriers (dialect).³⁶ Others studies corroborate the restriction of this mutation in Galician or Hispanic descendants in Portugal,³⁷ USA^{38,39} and Asturias (Northern Spain).³⁰

Although no Brazilian patient with the p.R71G reported a Spanish ancestry contribution, these patients presented considerable European ancestry contributions (Table 2), which was statistically significant ($r=0.604$), and historical data corroborate the hypothesis that the Northeast region of Brazil has a high Spanish ancestry contribution, especially Galician, because the State of Bahia received more Galician immigrants than others states. In Salvador, the capital of Bahia, from 1883 to 1950, approximately 3–6 generations ago (~20 years per generation), 94.3% of the Spanish immigrants were from Galicia, of which 90.8% were from Pontevedra Province.^{40,41} It is also important to emphasize that the likelihood of a *de novo* mutation occurring in *BRCA1* and *BRCA2* genes is very low.⁴²

The third mutation that was found, *TP53* p.R337H (0.94%), is a low-penetrance mutation that has a founder effect in the Southern region of Brazil and is associated with breast cancer cases that are related to Li–Fraumeni-like syndrome syndrome.^{4,11} It seems that p.R337H originated in the Portuguese population because the haplotypes of the Portuguese (A3) and the Brazilian (A1) carriers differ by only one SNP, rs9894946:C>T.¹¹

The frequency of the *TP53* p.R337H mutation in Southeast and South Brazil varies from 0.51 to 8.6%,^{43–45} and in the Northeast

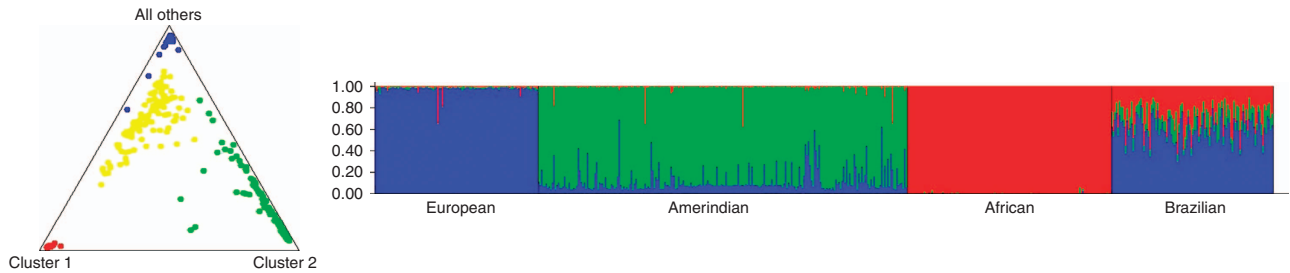

Figure 1. Distribution of the subjects according to their estimated ancestral background (triangle plot) and population structure for the trihybrid model (bar plot). Note: red dots, African population; green dots, Amerindian subjects; blue, European subjects; yellow dots, Brazilian population (study population).

Table 2. Characteristics of the patients with *BRCA1* and *TP53* mutations

Family/patient#	Cancer	Age at diagnostic ^a	Histology	Grade	U/B	ER	PgR	HER2	Self-reported color	Ancestry (%) ^b			Mutation
										Af	Am	Eu	
4.1	Ov/Br	38	-/Serous	-/II	U	—	—	—	White	14.6	10.1	75.3	<i>BRCA1</i> 3450del4
13.1	Br	47	IDC	—	U	—	—	—	White	29.2	9.6	61.2	<i>BRCA1</i> 3450del4
21.1	Br	32	IDC	—	U	—	—	—	White	19.8	14.4	65.8	<i>BRCA1</i> 3450del4
34.2	Br/Ov	39	IDC/serous	III/II	U	neg	neg	neg	White	27.0	6.5	66.5	<i>BRCA1</i> p.R71G
80.2	Br	46	Medular	X	U	neg	neg	neg	Mulatto	50.7	10.5	38.8	<i>BRCA1</i> p.R71G
97.1	Br	53	Lobular invasive	I	U	pos	pos	neg	White	17.4	6.3	76.3	<i>TP53</i> p.R337H
98.2	Br	38	IDC	III	U	neg	neg	neg	Mulatto	21.8	11.8	66.5	<i>BRCA1</i> 3450del4
103.1	Br	52	IDC	II	U	neg	neg	neg	Mulatto	17.5	10.1	72.4	<i>BRCA1</i> p.R71G
105.1	Br	39	IDC	III	U	neg	pos	neg	Mulatto	29.3	11.2	59.5	<i>BRCA1</i> p.R71G
106.1	Br	46	IDC	III	U	neg	neg	neg	Black	25.7	10.3	64.0	<i>BRCA1</i> p.R71G

Abbreviations: Af, African; Am, Amerindian; B, bilateral; Br, breast cancer; ER, estrogen receptor; Eu, European; HER2, human epidermal growth factor receptor; IDC, invasive ductal carcinoma; Ov, ovarian cancer; PgR, progesterone receptor; U, unilateral; —, data not available. ^aAge at diagnostic of the first cancer. ^bEstimated genetic ancestry.

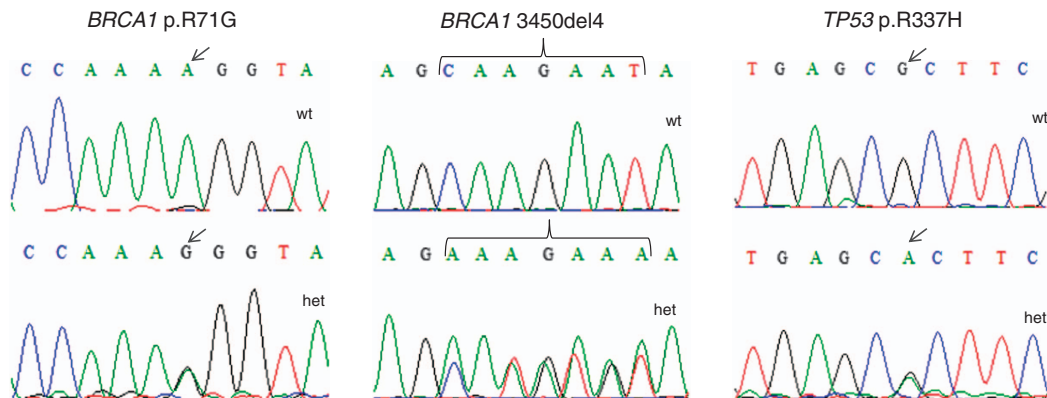

Figure 2. Sequencing fragments of carriers and noncarriers for the *BRCA1* p.R71G, *BRCA1* 3450del4 and *TP53* p.R337H mutations. Note: Het, heterozygous type; Wt, wild type.

population, this mutation occurred at a significant frequency (0.94%). However, here the mutation carrier had a family history that was suggestive of HBOC and not Li-Fraumeni Syndrome or Li-Fraumeni-like syndrome (Figure 2) based on the NCCN Clinical Practice Guidelines in Oncology v.1.2010⁴⁶ and criteria that were proposed by Li-Fraumeni, Birch, Eeles and Chompret.⁴⁷

However, this association was also recently found by Cury *et al.*⁴⁸ therefore, this finding demonstrated that in Brazil, the *TP53* p.R337H mutation is important for patients at high risk for HBOC as well as Li-Fraumeni Syndrome and Li-Fraumeni-like syndrome.

Consequently, in agreement with it has been recently proposed, the combined screening of *BRCA1*, *BRCA2* and *TP53* should be offered to high-risk patients as well as early-onset breast cancer patients from Brazil.^{44,49}

Interestingly, in this study we did not observe the *BRCA1* mutation that is the most frequent among the Brazilians: the *BRCA1* c.5266dupC (5382insC), which accounted for 56% of all of the identified mutations in patients from Southeast Brazil.⁵⁰ The highest frequency that was ever found in Brazil was 5% by Ewald *et al.*⁵¹ among high-risk patients for HBOC from Porto Alegre and Rio de Janeiro. Other studies in different regions of Brazil also

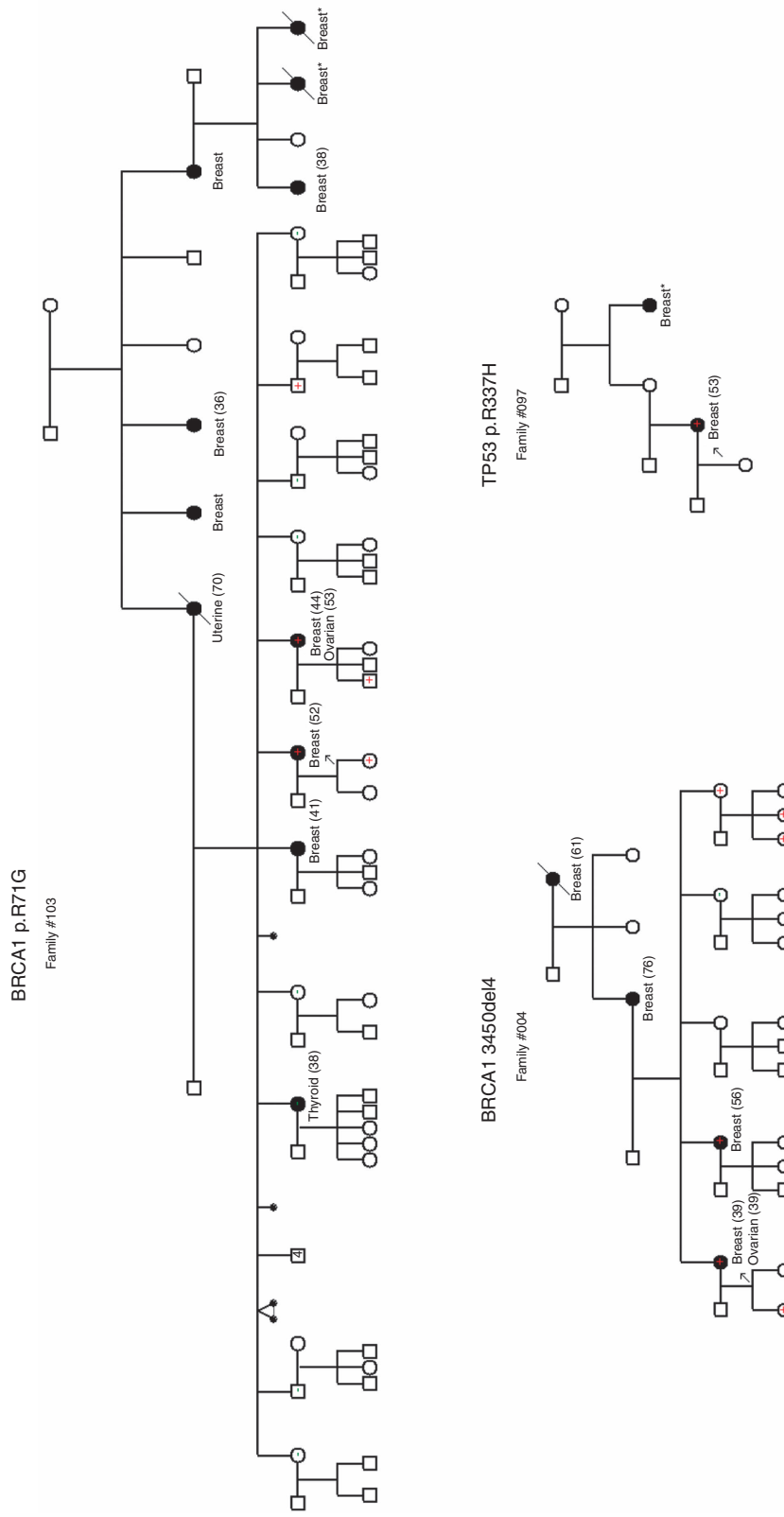

Figure 3. Pedigree of families harboring the *BRCA1* p.R71G, *BRCA1* 3450del4 and *TP53* p.R337H mutations. Note: positive (+) symbol, mutation carrier; negative (–) symbol, noncarrier; *age unknown. The numbers between parentheses represent the age at diagnosis in years.

found *BRCA1* c.5266dupC with a significant frequency,^{33,34,52} except among Ashkenazi women from Porto Alegre.⁵³

BRCA1 c.5266dupC was first described as an Ashkenazi founder mutation, but an analysis of the origin of this mutation in the European population demonstrated that c.5266dupC originated from a common ancestor in Northern Europe long before becoming an Ashkenazi founder mutation.⁵⁴ Because the Brazilian population has an ancestry contribution of many European populations, this mutation is likely to be found.

BRCA1 c.66_67delAG and *BRCA2* 6174delT, also considered Ashkenazi founder mutations,⁸ were found in other regions of Brazil^{34,53} as well as in Spanish and Latin America populations,^{26,35} and interestingly were not present in the population of Northeast Brazil; this result could also be because of the pattern of admixture of the Northeast population or even to the sampling size. However, the study population fit the Hardy–Weinberg Equilibrium ($P < 0.005$).

The other mutation of *BRCA2*, c.156_157insAlu, a Portuguese founder mutation,^{9,10} was also not found in this population, although historical data demonstrated that most of the European immigrants who arrived in Brazil were Portuguese, and it was the Portuguese that settled the country (1500), with a great immigrant flux between 1850 and 1970 that was two times greater than that of the Spanish population. However, when considering the number of immigrants by state, in 1950, Bahia State registered 2509 Spanish immigrants and 1531 Portuguese immigrants. In 1970, the number of Spanish immigrants was also higher than that of the Portuguese, at 3225 and 1586, respectively.^{16,55}

From the data presented here and the available historical data, it can be inferred that even though Salvador (the capital of the State of Bahia) was the first capital of Brazil (from 1549 to 1763), the presence of the Portuguese population in Bahia was smaller than that of the Spanish population, most likely due to the transference of the Portuguese court to Rio de Janeiro, the second capital of Brazil.¹⁶

In the estimated period of the first occurrence of *BRCA2* c.156_157insAlu in Portugal, 120–130 generations ago (~20 years per generation),⁹ the Portuguese immigrants were well established in Brazil, but because of economic and political motives, their presence was greater in Southeast Brazil, mainly in Rio de Janeiro and São Paulo. In Rio de Janeiro, *BRCA2* c.156_157insAlu was found in three unrelated patients with breast cancer.⁵⁶

Therefore, due to the bottleneck effect result of the Portuguese population movements, (a) immigration from Portugal to Brazil (settlement, 1500), (b) emigration from the Northeast to the Southeast regions of Brazil (the establishment of Rio de Janeiro as the capital of Brazil in 1973) and (c) others fluxes did not allow the fixation of *BRCA2* c.156_157insAlu in the population of Bahia.

The most frequent *CHEK2* germline mutations worldwide, c.1100delC, c.444+1G>A and p.I157T,^{5,57} were also not found in any of the analyzed patients. These data are interesting because mutations of low-penetrance genes are more likely to be found than are those of high-penetrance genes.

Nevertheless, it has to be considered that the presence of these mutations could also be related to the pattern of the admixture of the population. Other studies reported results similar to those presented here,^{22,52} and in Brazil, only one study found c.1100delC, but the affected individual had a family history matching the clinical criteria for hereditary breast and colorectal cancer.⁵⁸

In this study, the profile of a population that until now uncharacterized was analyzed; most of the subjects were from the largest state of the Northeast region (83.02%), but some were from other regions of Brazil (15.09%). In fact, it is important to consider that every population at some level is heterogeneous, some more than others, and that these variations can interfere with the level of genetic susceptibility.

Although the ancestry informative markers panel was relatively small, it could be observed that the study population was highly heterogeneous, presenting high levels of European ancestry contribution (62.20%), as well as significant African (31.20%) and Amerindian (6.60%) ancestry contributions. This high European ancestry contribution could be owing to fact that most of the subjects self-reported as white or mulatto (75.48%) and/or were from the countryside regions (52.83%), where there are more people with Caucasian traits than in Salvador, the capital of Bahia.^{17,18,59}

However, this degree of heterogeneity was confirmed in the population stratification analysis that was also statistically significant ($r=0.604$). In the bar plot, the degree of the genetic admixture of the study population was higher than that of the other population groups analyzed. In the triangle plot, the distribution of the study population was between the European and African populations. However, most Brazilian subjects clustered with the European populations, in which the degree of heterozygosity between individuals was higher (0.319) compared with the clusters of the African (0.262) and Amerindian (0.256) populations.

In Figure 1 (triangle plot), some individuals from the Amerindian population were not near its cluster (cluster 2) or seemed closer to the European cluster (cluster 3); this effect could be related to the size of the panel. Nonetheless, we must consider that there is genetic variation among and within populations; with this panel, a higher degree of heterogeneity of the study population was demonstrated.

In conclusion, in this highly admixed population, three founder mutations, *BRCA1* 3450del4 and p.R71G and *TP53* p.R337H, were found and can be added to the mutation panels that are used for high-risk HBOC patients and for early-onset breast cancer patients from this region. However, more importantly, these findings indicate that the combined screening of *BRCA1/2* and *TP53* is important and should be offered to high-risk patients. In addition, it is notable that this population seems to have a high Spanish ancestry contribution, considering that *BRCA1* p.R71G was found in a total of five unrelated patients. However, further genetic ancestry analysis could demonstrate whether the haplotype of these Brazilian patients is similar to that of the Galician patients.

COMPETING INTERESTS

The authors declare no conflict of interest.

ACKNOWLEDGEMENTS

We thank all of the patients and the institutions, NOB, Complexo HUPES/UFBA, HSA/OSID and CICAN, for their collaboration. We also thank Dr Fátima Vaz (Instituto Português de Oncologia, de Francisco Gentil) for kindly helping us develop the genotyping method for the *BRCA2* c.156_157insAlu mutation and Dr Mark Shriver (Penn State University) for kindly providing the genotypes of the African, Amerindian and European populations.

FUNDING

This study was supported by the Conselho Nacional de Desenvolvimento Científico e Tecnológico (Process #408858/2006-0) and Secretaria de Saúde do Estado da Bahia (Contract #028/2011).

REFERENCES

- 1 Jemal A, Bray F, Center MM, Ferlay J, Ward E, Forman D. Global Cancer Statistics. *CA Cancer J Clin* 2011; **61**: 69–90.
- 2 Smith EC. An overview of hereditary breast and ovarian cancer syndrome. *J Midwifery Womens Health* 2012; **57**: 577–584.
- 3 Apoustolou P, Fostira F. Hereditary breast cancer: the era of new susceptibility genes. *Biomed Res Int* 2013; **2013**: 74318.

- 4 Achatz MIW, Olivier M, Le Calvez F, Martel-Planche G, Lopes A, Rossi BM et al. The TP53 mutation, R337H, is associated with Li-Fraumeni and Li-Fraumeni-like syndromes in Brazilian families. *Cancer Lett* 2007; **245**: 96–102.
- 5 Allinen M M, Huusko P, Mäntyniemi S, Launonen V, Winqvist R. Mutation analysis of the CHEK2 gene in families with hereditary breast cancer. *Br J Cancer* 2001; **85**: 209–212.
- 6 Walsh T, Casadei S, Coats KH, Swisher E, Stray SM, Higgins J et al. Spectrum of mutations in BRCA1, BRCA2, CHEK2, e TP53 in families at high risk of breast cancer. *J Am Med Assoc* 2006; **295**: 1378–1388.
- 7 Bordeleau L, Panchal S, Goodwin P. Prognosis of BRCA-associated breast cancer: a summary of evidence. *Breast Cancer Res Treat* 2010; **119**: 13–24.
- 8 Struewing JP, Hartge P, Wacholder S, Baker SM, Berlin M, McAdams M et al. The risk of cancer associated with specific mutations of BRCA1 and BRCA2 among Ashkenazi Jews. *N Eng J Med* 1997; **336**: 1401–1408.
- 9 Machado PM, Brandão RD, Cavaco BM, Eugénio J, Bento S, Nave M et al. Screening for a BRCA2 rearrangement in high-risk breast/ovarian cancer families: evidence for a founder effect and analysis of the associated phenotypes. *J Clin Oncol* 2007; **25**: 2027–2034.
- 10 Peixoto A, Santos C, Rocha P, Pinheiro M, Príncipe S, Pereira D et al. The c.156_157insAlu BRCA2 rearrangement accounts for more than one-fourth of deleterious BRCA mutations in northern/central Portugal. *Breast Cancer Res Treat* 2009; **114**: 31–38.
- 11 Garritano S, Gemignani F, Palmero EI, Olivier M, Martel-Planche G, Le Calvez-Kelm F et al. Detailed haplotype analysis at the TP53 locus in p.R337H mutation carriers in the population of Southern Brazil: evidence for a founder effect. *Hum Mutat* 2010; **31**: 143–150.
- 12 Thorlacius S, Olafsdottir G, Tryggvadottir L, Neuhausen S, Jonasson JG, Tavtigian SV et al. A single BRCA2 mutation in male and female breast cancer families from Iceland with varied cancer phenotypes. *Nat Genet* 1996; **13**: 117–119.
- 13 Meijers-Heijboer H, van den Ouweland A, Klijn J, Wasielewski M, de Snoo A, Oldenburg R et al. Low-penetrance susceptibility to breast cancer due to CHEK2*1100delC in noncarriers of BRCA1 or BRCA2 mutations. *Nat Genet* 2002; **31**: 55–59.
- 14 Gilliland FD. Ethnic differences in cancer incidence: a marker for inherited susceptibility? *Environ Health Perspect* 1997; **105**: 897–900.
- 15 Neuhausen SL. Ethnic differences in cancer risk resulting from genetic variation. *Cancer* 1999; **86**: 2575–2582.
- 16 Instituto Brasileiro de Geografia e Estatística. *Brasil 500 anos de povoamento*, Centro de Documentação e Disseminação de Informações IBGE: Rio de Janeiro: Brasil, 2007.
- 17 Felix GES, Abe Sandes K, Bonfim TM, Bendicho MT, Cisneiros P, Guedes R et al. Ancestry informative markers and complete blood count parameters in Brazilian blood donors. *Rev Bras Hematol Hemoter* 2010; **32**: 282–285.
- 18 Abe-Sandes K, Bomfim TF, Machado TMB, Abe-Sandes C, Acosta AX et al. Ancestralidade genômica, nível socioeconômico vulnerabilidade ao HIV-aids na Bahia, Brasil. *Saúde Soc São Paulo* 2010; **19**: 75–84.
- 19 Luizon MR, Mendes-Junior CT, De Oliveira SF, Simões AL. Ancestry informative markers in Amerindians from Brazilian Amazon. *Am J Hum Biol* 2008; **20**: 86–90.
- 20 Parra FC, Amado RC, Lambertucci JR, Rocha J, Antunes CM, Pena SD. Color and genetic ancestry in Brazilians. *Proc Natl Acad Sci* 2003; **100**: 177–182.
- 21 Santos NP, Ribeiro-Rodrigues EM, Ribeiro-Dos-Santos AK, Pereira R, Gusmão L, Amorim A et al. Assessing individual interethnic admixture and population substructure using a 48-insertion-deletion (INSEL) ancestry-informative marker (AIM) panel. *Hum Mutat* 2010; **31**: 184–190.
- 22 Friedman L, Ostermeyer EA, Szabo CI, Dowd P, Lynch ED, Rowell SE, King Marie-Claire. Confirmation of BRCA1 by analysis of germline mutations linked to breast and ovarian cancer in ten families. *Nat Genet* 1994; **8**: 399–404.
- 23 Bayran S, Topaktaş M, Akkız H, Bekar A, Akgöllü E. CHEK2 1100delC, IVS2+1G>A and I157T mutations are not present in colorectal cancer cases from Turkish population. *Cancer Epidemiol* 2012; **36**: 453–457.
- 24 Custodio G, Taques GR, Figueiredo BC, Gugelmin ES, Oliveira Figueiredo MM, Watanabe F et al. Increased incidence of choroid plexus carcinoma due to the germline TP53 R337H mutation in Southern Brazil. *PLoS ONE* 2011; **6**: e18015.
- 25 Parra EJ, Marcini A, Akey J, Martinson J, Batzer MA, Cooper R et al. Estimating African American admixture proportions by use of population-specific alleles. *Am J Hum Genet* 1998; **63**: 1839–1851.
- 26 Shriver MD, Parra EJ, Dios S, Bonilla C, Norton H, Jovel C et al. Skin pigmentation, biogeographical ancestry and admixture mapping. *Hum Genet* 2003; **112**: 387–399.
- 27 Raymond M, Rousset F. GENEPOP (version 1.2): population genetics software for exact tests and ecumenicism. *J Hered* 1995; **86**: 248–249.
- 28 Chakraborty R. Gene identity in racial hybrids and estimation of admixture rates. In: Ahuja YR, Neel JV (eds). *Genetic Differentiation in Human and other Animal Populations*. Indian Anthropological Association: Delhi 1985: 171–180.
- 29 Falush D, Stephens M, Pritchard JK. Inference of population structure using multilocus genotype data: dominant markers and null alleles. *Mol Eco Notes* 2007; **7**: 574–578.
- 30 Blay P, Santamaria I, Pitiot AS, Luque M, Alvarado MG, Lastra A et al. Mutational analysis of BRCA1 and BRCA2 in hereditary breast and ovarian cancer families from Asturias (Northern Spain). *BMC Cancer* 2003; **13**: 243.
- 31 Rodriguez AO, Pardo GG, Royer R, Larson G, Weitzel JN et al. BRCA1 and BRCA2 mutations among ovarian cancer patients from Colombia. *Gynecol Oncol* 2012; **124**: 236–243.
- 32 Blesa JR, García JA, Ochoa E. Frequency of germ-line BRCA1 mutations among Spanish families from a Mediterranean area. *Hum Mut* 2000; **15**: 381–382.
- 33 Lourenço JJ, Vargas FR, Bines J, Santos EM, Lasmar CAP, Costa CH et al. BRCA1 mutations in Brazilian patients. *Genet Mol Biol* 2004; **27**: 500–504.
- 34 Esteves VF, Thuler LC, Amêndola LC, Koifman RJ, Koifman S, Frankel PP et al. Prevalence of BRCA1 and BRCA2 gene mutations in families with medium and high risk of breast and ovarian cancer in Brazil. *Braz J Med Biol Res* 2009; **42**: 453–457.
- 35 Vega A, Campos B, Bressac-De-Pailletres B, Bond PM, Janin N, Douglas FS et al. The R71G BRCA1 is a founder Spanish mutation and leads to aberrant splicing of the transcript. *Hum Mutat* 2001; **17**: 520–521.
- 36 Salas A, Comas D, Lareu MV, Bertranpetit J, Carracedo A. mtDNA analysis of the Galician population: a genetic edge of the European variation. *Eur J Hum Genet* 1998; **6**: 365–375.
- 37 Santos C, Peixoto A, Rocha P, Vega A, Soares MJ, Cerveira N et al. Haplotype and quantitative transcript analyses of Portuguese breast/ovarian cancer families with the BRCA1 R71G founder mutation of Galician origin. *Fam Cancer* 2009; **8**: 203–208.
- 38 John EM, Miron A, Gong G, Phipps AI, Felberg A, Li FP, West DW, Whittemore AS. Prevalence of pathogenic BRCA1 mutation carriers in 5 US racial/ethnic groups. *J Am Med Assoc* 2007; **298**: 2869–2876.
- 39 Weitzel JN, Lagos V, Blazer KR, Nelson R, Ricker C, Herzog J et al. Prevalence of BRCA mutations and founder effect in high-risk hispanic families. *Cancer Epidemiol Biomark Prev* 2005; **14**: 1666–1671.
- 40 Bacelar JA. *Galegos no Paraíso Racial*. Centro Editorial e Didático da UFBA. IANAMÁ: Salvador, Brasil, 1994.
- 41 Leira LP. *Galegos na Bahia de todos os Santos*Galicia en El Mundo Edicións. Editora Graciela Alba Burgos: Spain 2002: 10–22.
- 42 Zhang L, Fleischut MH, Kohut K, Spencer S, Wong K, Stadler ZK et al. Assessment of the prevalence of *de novo* mutations in the BRCA1 and BRCA2 genes. *Clin Genet* 2011; **80**: 97–98.
- 43 Ashton-Prolla P, Osorio CABT, Khoeler-Santos P, Graudenz MS, Palmero EI, Fernandes G et al. Contribution of TP53 p.R337H mutation to breast cancer prevalence in Brazil. *J Clin Oncol* 2012; (suppl 30): (abstr 1522).
- 44 Assumpção JG, Seidinger AL, Mastellaro MJ, Ribeiro RC, Zambetti GP, Ganti R et al. Association of the germline TP53 R337H mutation with breast cancer in southern Brazil. *BMC Cancer* 2008; **11**: 152.
- 45 Gomes MCB, Kotsopoulos J, de Almeida GL, Costa MM, Vieira R, Filho Fde A et al. The R337H mutation in TP53 and breast cancer in Brazil. *Hered Cancer Clin Pract* 2012; **10**: 3.
- 46 NCCN - National Comprehensive Cancer Network: Clinical Practice Guidelines in Oncology™. *Genetic/Familial High-Risk Assessment: Breast and Ovarian*, Hereditary Breast and/or Ovarian Cancer (HBOC-1) V.1; 2010. www.nccn.org.
- 47 Online Mendelian Inheritance in Man, OMIM Johns Hopkins University, Baltimore, MD. MIM Number: #151623. <http://omim.org/>. Accessed 4 January 2013.
- 48 Cury NM, Ferraz VE1, Silva WA Jr. TP53 p.R337H prevalence in a series of Brazilian hereditary breast cancer families. *Hered Cancer Clin Pract* 2014; **12**: 8.
- 49 McCuaig JM1, Armel SR, Novokmet A, Ginsburg OM, Demsky R, Narod AS et al. Routine TP53 testing for breast cancer under age 30: ready for prime time? *Fam Cancer* 2012; **11**: 607–613.
- 50 Gomes MC, Costa MM, Borojevic R, Monteiro AN, Vieira R, Koifman S, Koifman RJ et al. Prevalence of BRCA1 and BRCA2 mutations in breast cancer patients from Brazil. *Breast Cancer Res Treat* 2007; **103**: 349–353.
- 51 Ewald IP, Izetti P, Vargas FR, Moreira MA, Moreira AS, Moreira-Filho CA et al. Prevalence of the BRCA1 founder mutation c.5266dupin Brazilian individuals at-risk for the hereditary breast and ovarian cancer syndrome. *Hered Cancer Clin Pract* 2011; **9**: 12.
- 52 Carraro DM, Folgueira MAAK, Lisboa BCG, Olivieri EHR, Krepischi ACV, Carvalho AF et al. Comprehensive analysis of BRCA1, BRCA2 and TP53 germline mutation and tumor characterization: a portrait of early-onset breast cancer in Brazil. *PLoS ONE* 2013; **8**: e57581.
- 53 Dillenburg CV, Bandeira IC, Tubino TV, Rossato LG, Dias ES, Bittelbrunn AC et al. Prevalence of 185delAG and 5382insC mutations in BRCA1, and 6174delT in BRCA2 in women of Ashkenazi Jewish origin in southern Brazil. *Genet Mol Biol* 2012; **35**: 599–602.
- 54 Hamel N, Feng BJ, Foretova L, Stoppa-Lyonnet D, Narod SA, Imyanitov E et al. On the origin and diffusion of BRCA1 c.5266dupC (5382insC) in European populations. *Eur J Hum Genet* 2011; **19**: 300–306.

- 55 Levy MSF. O papel da migração internacional na evolução da população brasileira (1872 a 1972). *Rev de Saúde Pública* 1974; **3**: 49–90.
- 56 Moreira MAM, Bobrovnitshaia IG, Lima MA, Santos AC, Ramos JP, Souza KR *et al*. Portuguese c.156_157insAlu BRCA2 founder mutation: gastrointestinal and tongue neoplasias may be part of the phenotype. *Fam Cancer* 2012; **11**: 657–660.
- 57 Cybulski C, Górski B, Huzarski T, Masojć B, Mierzejewski M, Debniak T *et al*. CHEK2 is a multiorgan cancer susceptibility gene. *Am J Hum Genet* 2004; **75**: 1131–1135.
- 58 Abud J, Prolla JC, Rossi C, Palmero El, Vargas FR, Nunes LM *et al*. CHEK2 1100DEL C germline mutation: a frequency study in hereditary breast and colon cancer Brazilian families. *Arq Gastroenterol* 2012; **49**: 273–278.
- 59 Azevêdo E, Fortuna CM, Silva KM, Sousa MG, Machado MA, Lima AM *et al*. Spread and diversity of human populations in Bahia, Brazil. *Hum Biol* 1982; **54**: 329–341.



This work is licensed under a Creative Commons Attribution-NonCommercial-ShareAlike 3.0 Unported License. The images or other third party material in this article are included in the article's Creative Commons license, unless indicated otherwise in the credit line; if the material is not included under the Creative Commons license, users will need to obtain permission from the license holder to reproduce the material. To view a copy of this license, visit <http://creativecommons.org/licenses/by-nc-sa/3.0/>

Supplemental Information for this article can be found on the *Human Genome Variation* website (<http://www.nature.com/hgv>)