

Dimensional Accuracy of Hydrophilic and Hydrophobic VPS Impression Materials Using Different Impression Techniques - An Invitro Study

SREERAMULU BASAPOGU¹, AJAI PILLA², SUMAN PATHIPAKA³

ABSTRACT

Introduction: The dimensional stability of the impression material could have an influence on the accuracy of the final restoration. Vinyl Polysiloxane Impression materials (VPS) are most frequently used as the impression material in fixed prosthodontics. As VPS is hydrophobic when it is poured with gypsum products, manufacturers added intrinsic surfactants and marketed as hydrophilic VPS. These hydrophilic VPS have shown increased wettability with gypsum slurries. VPS are available in different viscosities ranging from very low to very high for usage under different impression techniques.

Aim: To compare the dimensional accuracy of hydrophilic VPS and hydrophobic VPS using monophasic, one step and two step putty wash impression techniques.

Materials and Methods: To test the dimensional accuracy of the impression materials a stainless steel die was fabricated as prescribed by ADA specification no. 19 for elastomeric impression materials. A total of 60 impressions were made. The materials were divided into two groups, Group 1 hydrophilic VPS (Aquasil) and Group 2 hydrophobic VPS (Variotime). These were further divided into three subgroups A, B, C for monophasic, one-step and two-step putty wash technique with 10 samples in each subgroup. The dimensional accuracy of the impressions

was evaluated after 24 hours using vertical profile projector with lens magnification range of 20X-125X illumination. The study was analyzed through one-way ANOVA, post-hoc Tukey HSD test and unpaired t-test for mean comparison between groups.

Results: Results showed that the three different impression techniques (monophasic, 1-step, 2-step putty wash techniques) did cause significant change in dimensional accuracy between hydrophilic VPS and hydrophobic VPS impression materials. One-way ANOVA disclosed, mean dimensional change and SD for hydrophilic VPS varied between 0.56% and 0.16%, which were low, suggesting hydrophilic VPS was satisfactory with all three impression techniques. However, mean dimensional change and SD for hydrophobic VPS were much higher with monophasic, mere increase for 1-step and 2-step, than the standard steel die ($p < 0.05$). Unpaired t-test displayed that hydrophilic VPS judged satisfactory compared to hydrophobic VPS among 1-step and 2-step impression technique.

Conclusion: Within the limitations of this study, it can be concluded that hydrophilic Vinyl polysiloxane was more dimensionally accurate than hydrophobic Vinyl polysiloxane using monophasic, one step and two step putty wash impression techniques under moist conditions.

Keywords: American dental association, Dimensional stability, Fixed prosthodontics, Impression techniques, Vertical profile projector

INTRODUCTION

Dental impression is a negative imprint of orofacial structures. Accuracy of impression is dependent on dimensional stability of impression material [1], and influenced by a number of factors such as impression technique, impression tray and properties of the impression materials [2]. An accurate impression is an important step in processing and final fitting of dental prosthesis [3].

Clinically elastic impression materials can be divided into two large groups:

- 1) Hydrocolloid impression materials that include agar-agar and alginate impression materials;
- 2) Synthetic elastomeric impression materials that include polysulfide, condensation silicone, addition silicone and polyether [4].

VPS impression materials were introduced in 1970's [5]. These materials have low polymerization shrinkage, low creep, good dimensional stability and surface detail reproduction. When compared with other types of impression materials, polyvinyl siloxane impression materials demonstrate superior dimensional stability, primarily because they do not release any by-product [6].

A significant limitation of VPS impression material is their hydrophobicity. There are two different aspects of the hydrophobic nature of VPS impression materials. The first aspect was related to surface free energy and the high contact angle of the solid polymerized VPS that had formed when polymerized VPS impression materials contact with the wet dental gypsum. The surface free energy of the unpolymerized, liquid phase of the impression material that lacks the ability to wet the oral tissues while impression making, forms the second aspect. Hence, certain intrinsic factors such as nonylphenoxypolyethanol homologues had been added by manufacturers to overcome the limitation of VPS hydrophobicity [7].

Impression techniques can be classified into monophasic and dual phase. Monophasic impression technique was completed in single step procedure by using medium viscosity impression materials; whereas putty and light body wash impression was used to complete the dual phase (1-step and 2-step putty/light body) impression technique [8].

AIM

In the present study dimensional accuracy of hydrophobic VPS and hydrophilic VPS compared using monophasic, single mix and

double mix impression techniques. The aims and objectives of this invitro study was

- To evaluate the dimensional accuracy of hydrophobic VPS using monophasic, one-step putty /light body impression and two - step putty/light body impression techniques.
- To evaluate the dimensional accuracy of hydrophilic VPS using monophasic, one-step putty /light body impression and two-step putty/light body impression techniques.
- To compare the dimensional accuracy of hydrophobic VPS and hydrophilic VPS using monophasic, one-step putty/light body impression and two-step putty/light body impression techniques.

MATERIALS AND METHODS

This invitro study was conducted in Department of Prosthodontics and Implantology, Government Dental College and Hospital, Hyderabad from the period 2012 to 2015. A stainless steel die was made according to ADA specification no 19. Die had a Ruled block and Mould [Table/Fig-1]. Ruled block had a height of 31 mm with diameter of inner ring and outer ring was 29.970 mm and 38 mm respectively. Mould had 30 mm inner ring and 38 mm outer ring with a height of 6mm.

Three vertical lines of width 0.016mm were made on the ruled block, which were labeled as X, Y, Z. The distance between two consecutive vertical lines was being 2.5 mm. Two horizontal lines were scored intersecting the vertical lines on either side with a distance of 25 mm between them. The intersection of vertical and

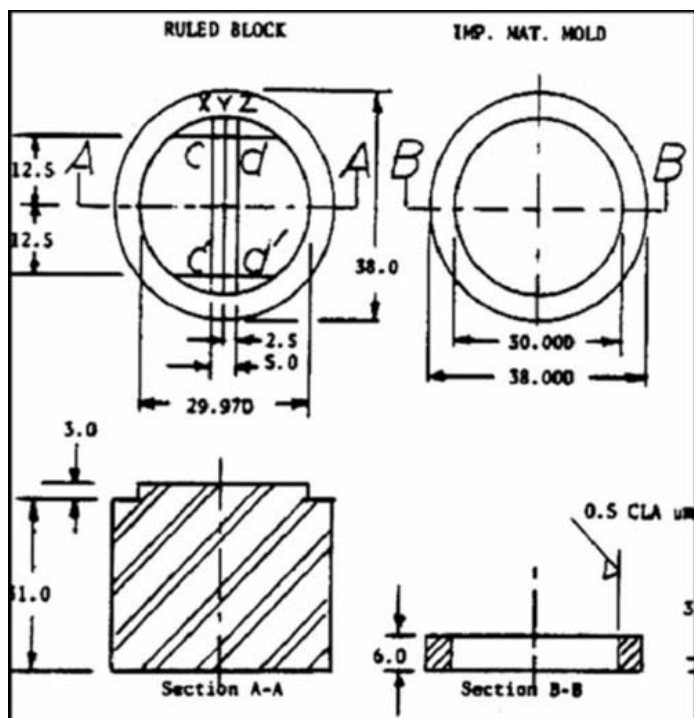

[Table/Fig-1]: Schematic scheme of Stainless steel die according to ADA specification No.19.

horizontal line Y was marked as x and x1 and served as the start and end points of measurements for dimensional accuracy.

Impression Procedure

30 impression samples each of hydrophilic VPS (aquasil) as Group 1 and hydrophobic VPS (variotype) as Group 2 were made using monophasic, 1-step and 2-step impression technique. These two groups were again divided into to three subgroups such as group A, B, C for monophasic, 1-step and 2-step putty wash impression technique. Each subgroup contained 10 impression samples. The impression materials used in this study were Aquasil (Dentsply/caulk, 78467, Kontanz, Germany) hydrophilic VPS of type 1

Product Name	Consistency	Batch No	Manufacturing company
Aquasil (Group 1)	Monophasic Light body Putty	Lot 130814 Lot 130430 Lot 1201001103	Dentsply/Caulk
Variotype (Group 2)	Monophasic Light body Putty	Lot 380148 Lot 390460 Lot 400352	Heraeus Kulzar

[Table/Fig-2]: Consistency, Batch No and Manufacturers of the impression materials evaluated.

Monophasic (Lot No 130814, Dentsply/Caulk), type 1 Light body (Lot No 130430, Dentsply/Caulk), Putty soft (Lot No 1201001103, Dentsply/Caulk) consistencies and hydrophobic VPS type 1 monophasic (Lot No 380148, Heraeus Kulzar), type 3 Light body (Lot No 390460, Heraeus Kulzar), easy putty (Lot No 400352, Heraeus Kulzar) [Table/Fig-2].

Prior to impression making, the die was cleaned ultrasonically so as to remove any residue. The die was air dried and care had been taken to avoid contamination of the die surface. Gloves have not used in this study as they inhibits polymerization process of elastomeric impression materials and also to avoid contamination of the die surface. By using auto mixing impression gun (Dentsply/Caulk), which was loaded with prepacked cartridges of impression material, the impressions were made. Fine mist of water ($32^{\circ}\text{C}\pm 2^{\circ}\text{C}$) was sprayed on to the surface of the die from a spray bottle before impression material was syringed onto the die surface. The mould was kept on the beveled area of the stainless steel die to ensure 3mm thickness of the impression.

For making impressions using monophasic technique, monophasic impression material was applied to the lined area of the die and was covered with polyethylene sheet. A glass plate was placed over it with a weight of 500gm on it and allowed to polymerize on stainless steel die for 12 minutes. The polymerization time was doubled, as recommended by the manufacturer, to compensate for impressions being made at room temperature (20°C) instead of at mouth temperature. No tray adhesive was used. The excess material was removed with a bard parker No.15 blade and impression was stored at room temperature. 10 impression samples each of hydrophilic VPS (Aquasil) and hydrophobic VPS (Variotype) were made using monophasic technique.

For making impressions using single mix technique light body was applied to the lined area of the die. Simultaneously, soft putty was mixed with finger tips for 30 seconds until the colour was uniform and was placed on the light body. Then the same procedure mentioned for monophasic impression was repeated. 10 impression samples each of hydrophilic VPS (Aquasil) and hydrophobic VPS (Variotype) were made using 1 step putty wash technique.

For making impressions using double mix impression technique (two-step putty wash technique), polyethylene spacer was placed on the die prior to putty impression to create space for light body material. Preliminary impression was first made using soft putty and was allowed to polymerize for 12 minutes. In second step the polyethylene spacer and putty impression were removed and light body impression material was syringed onto lined area of the die and on to the putty impression. A fine mist of water was sprayed from a standard distance of 15mm using spray bottle. Preliminary putty impression was reinserted along with light body and evaluated for fit on the die until mould made a firm contact with beveled area of the die. Ten impression samples each of hydrophilic VPS (Aquasil) and hydrophobic VPS (Variotype) were made using two-step putty wash technique.

EVALUATION OF DIMENSIONAL ACCURACY

In this study dimensional accuracy was determined by measuring the dimensional change of line Y between points x and x1 three times using the vertical profile projector [Table/Fig-3]. The three



[Table/Fig-3]: Vertical Profile Projector.

measured values were averaged and compared with the original length of line Y of the stainless steel die. The measurements were made after 24 hours of impression making. The percentage of dimensional change was measured using the formula: % dimensional change = $A-B/B \times 100$. (A- Length of measured line Y of this specimen in mm, B- length of line Y on stainless steel die.

STATISTICAL ANALYSIS

This study used one-way analysis of variance (ANOVA) to compare means within the groups. A post-hoc test for multiple mean comparisons was done using Tukey HSD test. Comparison between the groups was done using Unpaired t- test.

RESULTS

The mean values of hydrophilic VPS (Aquasil) for 10 measurements with each impression technique and the corresponding SD and % dimensional change were calculated. The percent errors were low, ranging from 0.56% to 0.16% [Table/Fig-4]. The mean values, SD and % dimensional change of hydrophobic VPS (Heraeus Kulzar) for 10 measurements according to impression technique were calculated. All impression dimensions were greater than that of stainless steel die [Table/Fig-5].

The one-way ANOVA for the samples of hydrophilic VPS [Table/Fig-6] revealed that all the dimensions were not significantly different among the impression techniques. Significant difference was noted

	Monophase	1-step	2-step
Mean	25.14	25.05	25.04
S.D	0.87	0.03	0.04
% dimensional change	0.56	0.20	0.16

[Table/Fig-4]: Means, S.D & % dimensional changes of hydrophilic VPS (Aquasil, Densply/Caulk) for the three impression techniques.

	Monophase	1-step	2-step
Mean	25.13	25.10	25.11
S.D	0.17	0.07	0.05
% dimensional change	0.50	0.40	0.44

[Table/Fig-5]: Means, S.D % dimensional changes of hydrophobic VPS (Variotem, Heraeus Kulzar) for three impression techniques.

Anova Test					
Source of Variation	Sum of Squares	Df	Mean Square	F-value	p-value
Between Subgroups	0.20	2	0.102	0.400	0.671 Not significant
Within Subgroups	22.23	87	0.256		
Total	22.44	89			

[Table/Fig-6]: Mean comparison among subgroups in group I using one-way ANOVA test. Statistical Analysis: ANOVA test. Statistically significant if $P < 0.05$, Df = degree of freedom

Anova Test					
Source of Variation	Sum of Squares	Df	Mean Square	F value	p-value
Between Subgroups	0.195	2	0.097	6.865	0.002 Significant
Within Subgroups	1.234	87	0.014		
Total	1.429	89			

[Table/Fig-7]: Mean comparison among sub groups in group 2 using one-way ANOVA test. Statistical Analysis: ANOVA test. Statistically significant if $P < 0.05$, Df = degree of freedom

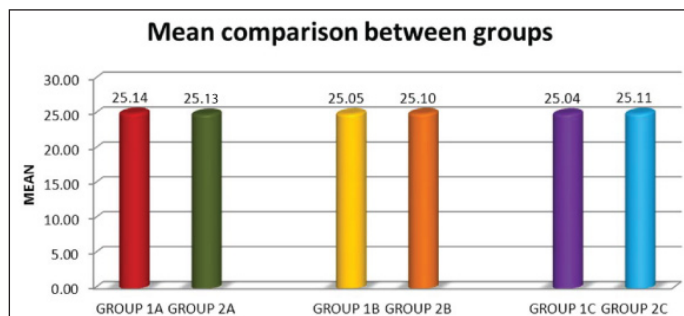

[Table/Fig-8]: Comparison of mean values between group I and group II using Monophase, 1-step, 2-step putty wash impression techniques.

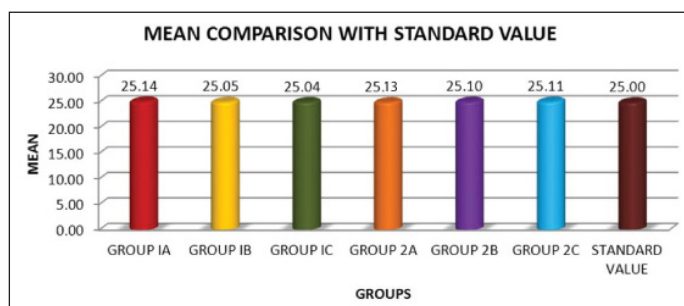

[Table/Fig-9]: Mean comparisons of group I and group II with standard value.

among the impression techniques among the hydrophobic VPS group using one-way ANOVA test [Table/Fig-7]. In general greater percentage deviation was observed for monophase impression technique in both the groups. Unpaired t-test revealed statistically significant ($p < 0.05$) difference between one-step and two- step techniques among the groups [Table/Fig-8,9].

DISCUSSION

In the present study, the accuracy of three impression techniques was investigated using hydrophilic VPS and hydrophobic VPS impression materials. In this study no gloves were used to manipulate the elastomeric impression material as well as to avoid contamination of the die surface. For all the groups, significantly larger dimension impression samples were observed compared to stainless steel model. The evidence from this investigation indicated that accuracy of the two impression materials used was not much adversely affected by the presence of moisture.

The results of this invitro investigation should be viewed cautiously because laboratory testing cannot exactly replicate clinical situations. In this investigation, impressions were made of standardized stainless steel dies. Metal dies were non-absorbent to liquids unlike oral tissues. Proteinaceous surfaces of prepared teeth and oral soft tissues had a lesser surface energy than surface free energy of a metal die. Wetting of impression material depended on surface energy of impressed surface. The source of moisture was water, not the saliva, which was again a drawback.

The monophase technique is the easiest to perform, but it has been reported to be the worst in terms of dimensional accuracy and surface defects, as compared to putty light body techniques, because of relatively high viscosity and reduced flow of material used. In one-step technique the putty tends to push the light body wash

off the prepared tooth, thus critical areas such as the finish line can be covered by putty that cannot record the details to a satisfactory level. Another difficulty with the one- step technique is that once the light body material is on the preparation, the putty needs to be brought into position and seated. During this critical phase, patients tongue or the elevated floor of the mouth can remove the light body material from the tooth. The two-step technique allows these problems to be overcome by diminishing the volume of polymerizing material at each stage, the final contraction can be reduced, and also the accuracy of the impression improved. Therefore, careful control of the bulk of light body impression material has been advocated because it affects the accuracy of stone casts.

When allowed to polymerize in moist field hydrophobic VPS has a lesser dimensional accuracy in comparison to hydrophilic VPS. ADA specification 19 protocol was used for measurement of dimensional accuracy. In previous studies dimensional changes of impression materials were measured on plaster casts poured of impressions by various devices like traveling microscope, digital vernier calipers, 3 dimensional Zeiss meter and stereomicroscope [9,10]. However, in this study to eliminate possibility of changes in stone casts, measurements were directly performed on the impression using Digital Profile Projector.

However, while the results from three impression techniques revealed two-step impression technique was advantageous in both hydrophilic and hydrophobic VPS with all three impression techniques. Impression accuracy was not technique-dependent as stated by Idris et al., [11]. Hung et al., comparatively studied the accuracy of two VPS impression techniques, the study was performed in 1 step and 2 step with a polyethylene spacer. They concluded that there was no difference between the two techniques [12]. However, Joseph Nilsson et al., stated that the technique is a crucial factor that influences the accuracy of the impression [13]. This invitro suggests that the technique can be significant factor in determining dimensional accuracy of impressions.

LIMITATIONS

1. In this study the metal dies were non-absorbent to liquids unlike oral tissues.
2. Source of moisture was water not the saliva in this study which again a drawback.

Clinical transfer: These results suggest that hydrophilic materials with 2 step impression technique leads to predictable success in the Fixed prosthodontics and Implantology procedures.

CONCLUSION

Within the limitations of this invitro study, the following conclusions can be drawn:

- Hydrophilic VPS yielded more dimensionally accurate impressions than hydrophobic VPS using one step, two step putty wash impression techniques.
- In monophasic technique, no much difference was found between the hydrophilic and hydrophobic VPS impression materials.
- Hydrophilic VPS yielded dimensionally accurate impressions in all the three impression techniques.
- Hydrophobic VPS gave better dimensionally accurate impressions in one step, two step putty wash techniques in comparison to monophasic impression technique.

REFERENCES

- [1] Markovic D, Puskar T, Hadzistevic M, Potran M, Blazic L, Hodolic J. The dimensional stability of elastomeric dental impression materials. *Contemporary Materials*. 2012;III-1:105-10.
- [2] Stober T, Johnson GH, Schmitter M. Accuracy of the newly formulated vinyl siloxane ether elastomeric impression materials. *J Prosthet Dent*. 2010;103(4):228-39.
- [3] Piwowarczyk A, Ottl P, Buchler A, Lauer HC, Hoffmann A. Invitro study of dimensional accuracy of selected materials for monophasic elastic impression making. *Int J Prosthodont*. 2002;15(2):168-74.
- [4] Chen SY, Liang WM, Chen FN. Factors affecting the accuracy of elastomeric impression materials. *J Dent*. 2004;32(8):603-09.
- [5] Wadhvani CP, Johnson GH, Lepe X, Raigrodski AJ. Accuracy of newly formulated fast-setting elastomeric impression materials. *J Prosthet Dent*. 2005;93(6):530-39.
- [6] Craig RH. A review of properties of rubber impression materials. *J Mich Dent Assoc*. 1977;59:254-61.
- [7] Petrie CS, Walker MP, O'mahony AM, Spencer P. Dimensional accuracy and surface detail reproduction of two hydrophilic vinyl polysiloxane impression materials tested under dry, moist, and wet conditions. *J Prosthet Dent*. 2003;90(4):365-72.
- [8] Caputi S, Varvara G. Dimensional accuracy of resultant casts made by a monophasic, one-step and two-step, and a novel two-step putty/light-body impression technique: An invitro study. *J Prosthet Dent*. 2008;99(4):274-81.
- [9] Reports of Council and bureaus revised American Dental Association Specification no.19 for Non-Aqueous, Elastomeric Dental impression materials. *J Am Dent Assoc*. 1977;94(4):733-41.
- [10] Pedroso LM, Paloma P, Paula SA, Pick OB. Dimensional stability of a novel polyvinyl siloxane impression technique. *Braz J Oral Sci*. 2014;13(2):118-23.
- [11] Idris B, Houston F, Claffey N. Comparison of the dimensional accuracy of one- and two-step techniques with the use of putty/wash addition silicone impression materials. *J Prosthet Dent*. 1995;74(5):535-41.
- [12] Hung SH, Purk JH, Tira DE, Eick JD. Accuracy of one-step versus two-step putty wash addition silicone impression technique. *J Prosthet Dent*. 1992;67(5):583-89.
- [13] Nissan J, Laufer BZ, Brosh T, Assif D. Accuracy of three polyvinyl siloxane putty-wash impression techniques. *J Prosthet Dent*. 2000;83(2):161-65.

PARTICULARS OF CONTRIBUTORS:

1. Associate Professor and Incharge, Department of Prosthodontics, GDCH, Hyderabad, Telangana, India.
2. Student, Department of Prosthodontics, GDCH, Hyderabad, Telangana, India.
3. Student, Department of Prosthodontics, GDCH, Hyderabad, Telangana, India.

NAME, ADDRESS, E-MAIL ID OF THE CORRESPONDING AUTHOR:

Dr. Sreeramulu Basapogu,
Associate Professor and Incharge, Department of Prosthodontics, Government Dental College & Hospital,
Afzalgunj, Hyderabad. 500012. Telangana, India.
E-mail: drsreeramulub@gmail.com

FINANCIAL OR OTHER COMPETING INTERESTS: None.

Date of Submission: **Oct 14, 2015**

Date of Peer Review: **Nov 24, 2015**

Date of Acceptance: **Jan 07, 2016**

Date of Publishing: **Feb 01, 2016**