

A RAPID "SIDE-ROOM" METHOD FOR THE DETERMINATION OF PLASMA FIBRINOGEN CONCENTRATION AS FIBRIN

BY

G. I. C. INGRAM AND MYRTLE O. MATCHETT

From the Louis Jenner Laboratory and Department of Clinical Pathology, St. Thomas's Hospital and Medical School, London

(RECEIVED FOR PUBLICATION MARCH 31, 1960)

A method is proposed for the rapid estimation of plasma fibrinogen concentration. The technique depends on the increase of optical density occurring when plasma clots. A kit is described which obviates the use of laboratory apparatus, so that the test may be performed in the ward side-room if a small centrifuge can be provided.

A calibration curve has been prepared for use with commercial opacity standards, and a measure of the error of the method has been obtained.

It would seem that when haemostatic function is in doubt, the fibrinogen concentration of plasma is more appropriately determined as material capable of clotting, i.e., as fibrin, than in terms of a precipitate thrown down by standard unphysiological conditions. While citrated plasma readily forms a clot on recalcification, methods previously suggested for the estimation of clot usually demand specialized equipment and are often time-consuming.

Rapid, simple methods recently proposed for

fibrinogen determination have been based on unphysiological procedures, or have employed the reaction with thrombin to provide a more qualitative test. The use of this latter test is obviously important and is discussed below, but there still seems to be a place for a method for rapidly estimating clot with simple equipment.

The optical opacity of plasma increases markedly on coagulation. The rise in opacity bears a close relation to fibrin mass, and the conditions which govern this relation have received

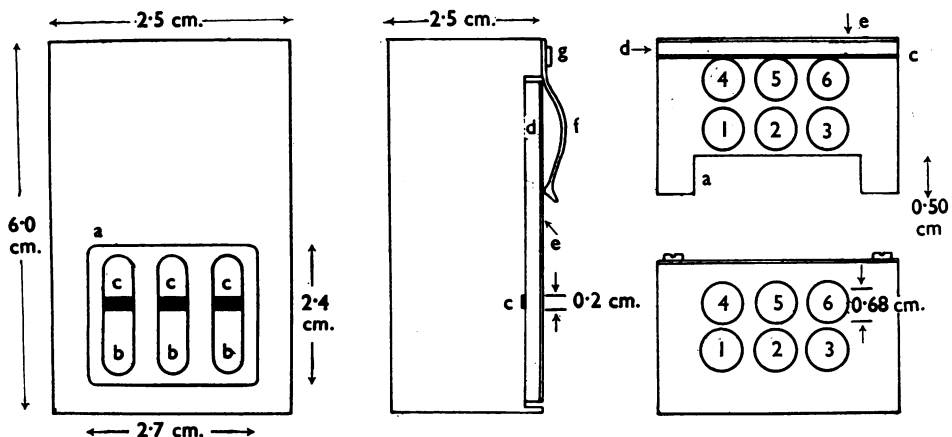

FIG. 1.—Diagram of the comparator block. The prototype was machined in ebonite, and the black line was drawn in Indian ink on a piece of glass cut from a shell-backed sheet such as is used for viewing by transmitted light the agglutination in the Race-Coombs test. The block is recessed at *a* over the viewing slits *b* through which is seen the black line *c* inscribed on the glass *d* with shell back *e*. The glass is held in position by the spring clip *f* bolted to the block at *g*.

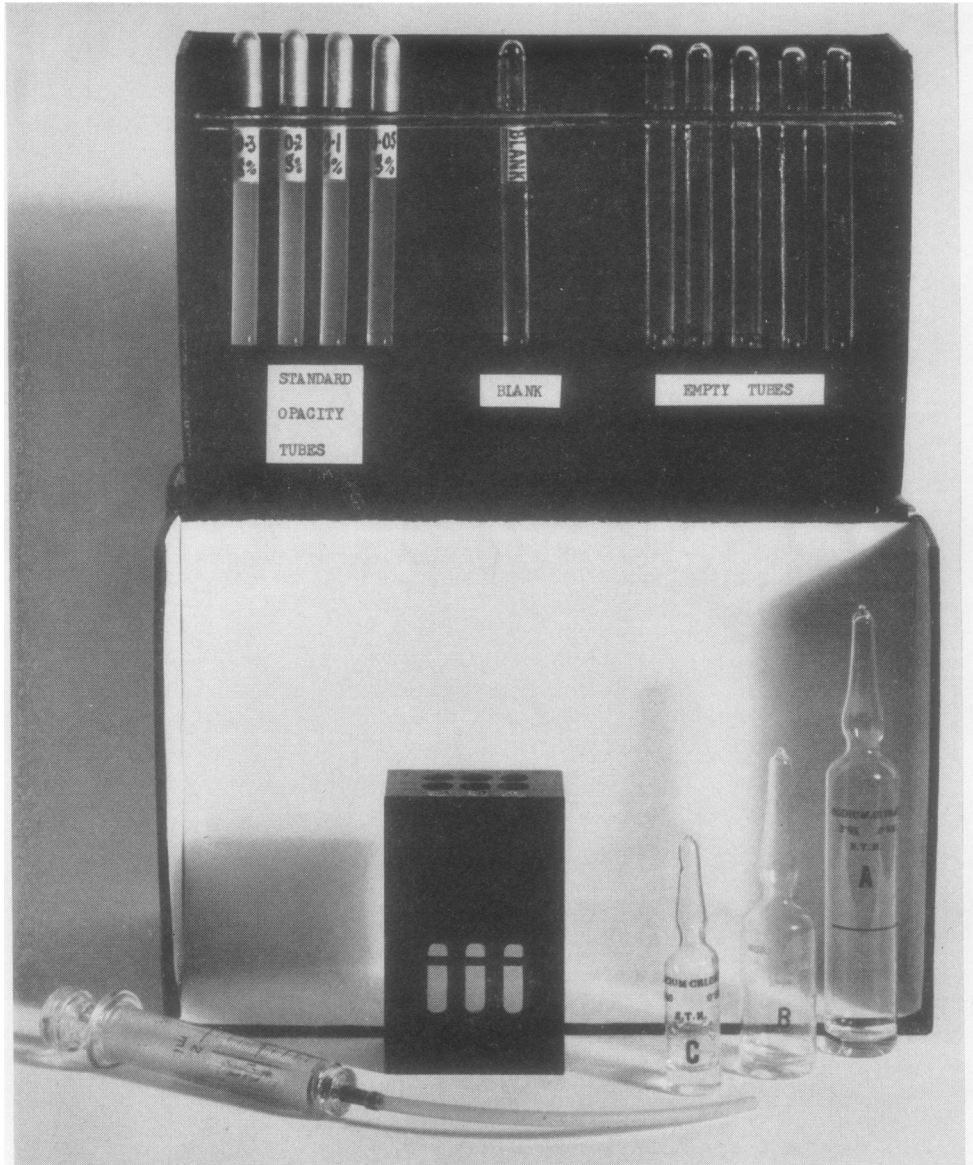

FIG. 2.—The side-room assembly. The ampoules contain measured volumes of the reagents required for a single test, and the opacity standards are calibrated in fibrinogen concentrations. If laboratory glassware is not available, the plasma can be measured by a syringe carrying a length of polythene catheter (as shown) or a wide-bore needle.

considerable attention (Nygaard, 1941; Burstein and Loeb, 1952). The method here proposed exploits this relationship.

Method

Principle.—Citratd plasma is recalcified and allowed to clot in a precipitin tube ($\frac{1}{4}$ in. \times 4 in.). The opacity of the clot is determined by comparison with a series of Brown and Kirwan's (1915) standard opacity tubes

which are commercially available. Colour correction is obtained by viewing the standard tubes through the same plasma similarly treated with saline in a two-row, six-hole comparator block.

To facilitate using in a side-room, the reagents may be prepared in ampoules containing the exact amounts required for each test; and the plasma may be manipulated with syringes if laboratory glassware is not available.

Equipment.—The following is required:

(1) A set of opacity standards, including a "blank" tube containing only the gelatin used to suspend the opaque material in the standards. It is suggested that for obstetric use it would be sufficient to provide four standards corresponding to 0.3 g.% (lower limit of normal late pregnancy), 0.2 g.% (lower limit of non-pregnant normal, i.e., presumptive haemostatic sufficiency), 0.1 and 0.05 g.% (representing moderate and severe deficiency respectively).

(2) A comparator block with six holes, to take ¼ in. tubes (17/64 in. drill) (Fig. 1).

(3) Empty ¼ in. × 4 in. glass tubes (three are required for a test).

(4) Flat-bottomed ampoules of reagents, containing (a) 0.5 ml. 3.8% sodium citrate solution in a 10 ml. ampoule, graduated at 5.0 ml.; the ampoule diameter should not exceed 5/8 in. so as to fit the test-tube-size metal bucket of a centrifuge; (b) 0.5 ml. 0.85% saline; (c) 0.5 ml. 0.025 M (0.28%) calcium chloride solution.

(5) Lengths of soft polythene catheter, about 3½ in.; size 4 fits a "record" syringe nozzle.

These items are shown together in Fig. 2. In addition, the only piece of standard equipment required is a centrifuge to spin the citrated blood, since the test must be made on plasma.

Technique.—(1) Open one each of the ampoules marked (a), (b), and (c), having shaken down any solution held in the necks. Stand the ampoules upright on the bench.

(2) Fill (a) up to the mark with blood and mix by gentle inversion. Centrifuge the ampoule for 5 min. at about 3,000 r.p.m. (see that the upper part of the opened ampoule projects sufficiently from the centrifuge bucket for easy withdrawal).

(3) If laboratory glassware is not available, push a length of polythene tubing or a long, wide-bore needle on to the nozzle of a 1 ml. or 2 ml. syringe. Suck up 1.0 ml. of clear plasma and run 0.5 ml. into (b) and into (c). Mix the contents of (b) and apportion the liquid between two of the glass tubes by means of the syringe. Then immediately mix the contents of (c) and similarly transfer about half its contents to a third tube. The tubes filled from (b) are placed in holes 1 and 3 of the comparator and the tube filled from () in hole 5.

(4) Set the comparator aside for 10 to 20 min. for clotting to occur. (If the clotting tube can be incubated at 37° C., 5–10 min. will suffice.)

(5) Place the "blank" tube in hole 2 of the comparator, and, viewing through the slits in the front face, match the opacity seen through the central slit against standard tubes placed in holes 4 and 6 and seen through the side slits. It is helpful to consider together adjacent pairs of standard tubes, to define the opacity range which brackets that of the test plasma.

Notes.—(1) See that all glass tubes are quite clean over the lowermost inch of their length.

(2) Hold the comparator against a uniform diffuse white light when viewing. Some workers may prefer to match opacities by the degree of blurring of the black line, while others may find it easier to judge by the relative darkening of the bright ground. Strictly speaking, the value obtained will always be an underestimate, because of the dilution of the plasma with the citrate solution,

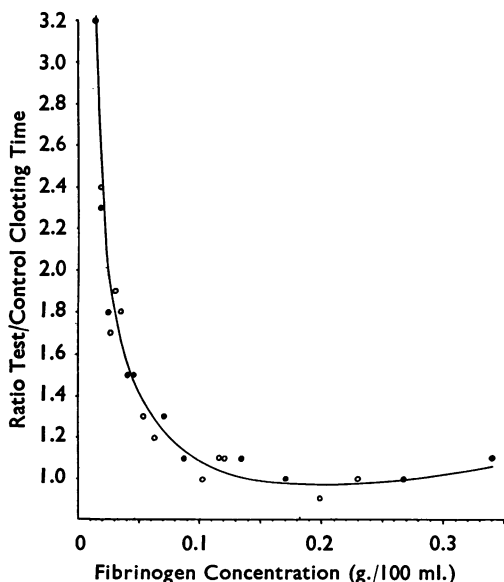

FIG. 3.—The relation between thrombin clotting time and fibrinogen concentration. The tests were made with a solution of human thrombin in M/80 calcium chloride solution, giving a control plasma clotting time of about 10 sec. when 2 volumes of thrombin solution were added to 1 volume of plasma. The plasma samples were those of Fig. 4.

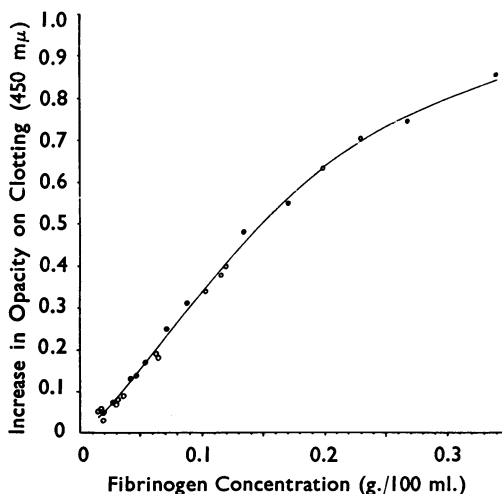

FIG. 4.—The relation between increase of plasma opacity on clotting and fibrinogen concentration. Measurements were made on 24 mixtures of whole and defibrinated plasmas prepared from normal and phenindione-treated subjects. Increase in opacity was obtained from the difference between the opacities (against water) of the recalcified, citrated plasma before and after clotting.

but the proportionate effect (which may be calculated in a given case from the haematocrit) is usually of such an order that the estimate is not less than 0.80 to 0.85 of the true value, an error which would be of small account under the proposed conditions of testing.

The quantitation of the method and an investigation of errors is given in the Appendix.

Relation Between Fibrinogen Concentration and Thrombin Clotting Time

One more point was investigated. Sharp, Howie, Biggs, and Methuen (1958) described three obstetrical cases in which the fibrinogen concentration had been reported normal but the thrombin clotting time was grossly prolonged. The significance of this finding is not yet clear, but it was thought of interest to provide a chart showing the relation between thrombin clotting time and the concentration of normal fibrinogen for comparison (Fig. 3). The readings were taken in the specimens providing the data for Fig. 4; the clotting times of the mixtures of whole and defibrinated plasmas were expressed as ratios of the clotting times of the corresponding untreated plasma pools.

We would like to thank our obstetrical colleagues for their encouragement in this investigation; and we are indebted to Dr. P. Armitage, of the Medical Research Council's Statistical Research Unit, for his advice on the investigation of the errors of the methods, and to Dr. A. J. Buller, of the Department of Physiology, St. Thomas's Hospital Medical School, for a discussion of the incremental sensitivity of the eye.

APPENDIX

Quantitative Basis

In developing the method, the relationship between opacity increase and fibrin mass was established by preparing from a number of pools of fresh, citrated human plasma several mixtures of whole and thrombin-defibrinated (Warner, Brinkhous, and Smith, 1936) plasma in differing proportions, and then measuring in each mixture both the opacity increase during clotting and the fibrin content (Ingram, 1952). The opacity measurements were made on a "unicam" S.P. 350 diffraction-grating spectrophotometer (with fixed slit-width), set at 450 $m\mu$ to obtain maximal dispersion. Plasma pools from both normal and phenindione-treated persons were examined, to detect systematic effects from at least a moderate coagulation defect. The results (Fig. 4) show a close correlation between the two series of measurements. There was no evidence of systematic differences between plasma pools or between plasmas from normal and phenindione-treated subjects.

Next, an aqueous suspension of the opaque material used in preparing the commercial Brown and Kirwan's standard opacity tubes was obtained by courtesy of the

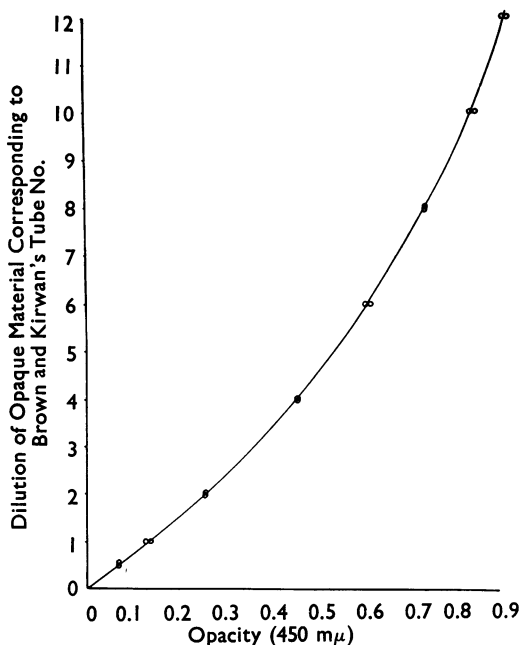

Fig. 5.—The opacity of the dilutions of opaque material used in the marketed series of Brown and Kirwan's standard tubes. (The numbers indicating the tube opacities are the numerators of the fractions, 12/12, 11/12, 10/12, . . .) The readings were taken under the same conditions as were employed for Fig. 3.

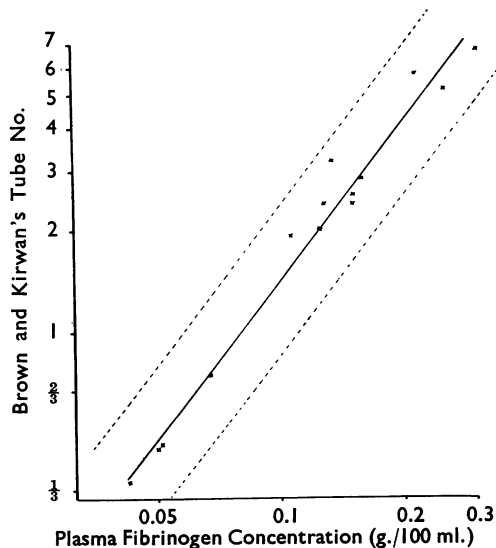

Fig. 6.—Calibration curve for Brown and Kirwan's standard opacity tubes (Wellcome Foundation Ltd.) in terms of fibrin content of clotted plasma. Fourteen different concentrations of fibrinogen in plasma were each examined in the comparator by six observers. The figure shows the mean readings for each fibrinogen concentration, and the ± 2 S.D. limits for a single observer testing single samples of different plasmas on different occasions. The correlation coefficient for the 84 readings is +0.96 and the equation to the line is $Y = 52 X^{1.6}$ where Y is the opacity of the standard tube in conventional numbering, and X is the fibrinogen concentration of the plasma in g./100 ml.

TABLE I
ANALYSIS OF VARIANCE OF 84 READINGS OF THE COMPARATOR WITH PLASMAS OF KNOWN FIBRINOGEN CONTENT

Contribution		Degrees of Freedom	Sums of Squares	Mean Square	Variance Ratios
1.	<i>Between fibrinogen concentrations</i>	13			
	Either				
	(i) Between slopes	6	9.40		
	(ii) Due to parallel lines	1	837.43	1.57	n.s.
	(iii) Between concentrations within plasmas	7	846.83		
	(iv) " plasmas	6	529.98		
	Or				
	(v) Deviation of plasma means from line having the " within plasmas " slope	6	28.57	4.76	3.84†
	(vi) Deviations within plasmas from parallel lines	6	9.40		
	(vii) Deviations from overall slope	12	37.97		
	(viii) Overall slope	1	1,338.85		
2.	<i>Between observer pairs</i>	2			
	(i) Regression on skill	1	6.45	6.45	5.19†
	(ii) About regression	1	0.30		
3.	<i>Fibrinogen concentration × observer pairs</i>	26	32.25	1.24 (2.18*)	1.00
4.	<i>Error, within observer pairs</i>	42			
	(i) Systematic	3	5.93	1.98 (3.47*)	
	(ii) Residual	39	22.07	0.57 (1.00)	
	Total	83	1,443.82		

Seven plasma samples each provided two fibrinogen concentrations and each one was estimated by six observers. The analysis was made in logs. to facilitate the computations involving the regression of comparator reading on fibrinogen concentration. The transformation had the incidental effect that the variability of the lower readings became rather greater than that of the higher readings. The error within observer pairs (4, i) showed no evidence of a regression on skill. The significant interaction (3) is thought to be due to circumstantial differences between different occasions of observation, such as differing intensities of lighting, and is therefore used to test the significance of the main effects.

Level of significant variance ratios: * 5%; † 1%; n.s., not significant at 5%.

Wellcome Foundation Ltd. Dilutions (10/12, 8/12, 6/12 . . .) were prepared corresponding to the usual series of tubes marketed and their opacities were measured under similar conditions. The results (Fig. 5) show that this range conveniently covers that of fibrinogen concentrations of clinical importance in obstetric emergencies.

The direct calibration of Brown and Kirwan's tubes in the comparator was made by visual comparison, as in ordinary use, with a series of mixtures of whole and defibrinated plasmas from seven individual citrated blood samples, so that each sample provided two differing mixtures. The fibrin contents of the mixtures were determined as before, and in each instance comparator readings were taken by six persons, who remained the same throughout the series, namely, the authors, two experienced laboratory workers who had not previously used this technique, and two laboratory secretaries, the three groups representing three degrees of skill with the method. The observers stated their score to the nearest standard tube, without interpolating. The paired mixtures from each plasma were examined concurrently, but each pair was handled on a different day. Eighty-four readings were thus obtained, six of each of 14 different concentrations of fibrinogen, over seven days.

The results are shown graphically in Fig. 6, in which the mean readings for the six observers are plotted against fibrinogen concentration to show the (significant) scatter of plasma means about the regression line calculated for all the 84 readings.

The analysis of variance is given in Table I. From this the various components of the error of a single reading may be obtained. For instance, taking the degree of variation found among observers and among plasmas

and choosing an observer and a plasma sample at random on any day, if the fibrinogen concentration were read from the regression line of Fig. 6, the true fibrinogen concentration would be expected to lie between the limits:

Estimated value × 1.41 to estimated value × 1/1.41 in 19 out of 20 trials. If, however, the sources of variation are considered separately, the corresponding limits are given in Table II, where they are computed so as to provide a test for the significance of the difference between two readings, since this is likely to be a more difficult assessment than the simple detection of abnormality.

It is clear from the analysis that there was little discrepancy between observers in matching the appro-

TABLE II
ESTIMATES OF ERROR OF METHOD EXPRESSED AS A TEST FOR SIGNIFICANCE OF DIFFERENCE BETWEEN TWO INDIVIDUAL RESULTS UNDER VARIOUS CONDITIONS (95% CONFIDENCE LEVEL)

Conditions	Critical Ratio
1. Different observers taking single readings on different plasmas on different occasions	1.61
2. The same observer taking single readings on different plasmas on different occasions	1.57
3. Different observers taking single readings on different occasions on the same plasma	1.53
4. The same observer taking single readings on different occasions on the same plasma	1.49

To be significantly different, the two results must differ by a ratio greater than the critical value tabulated. Thus, suppose an observer obtains a reading of 0.10 g./100 ml. on a given patient, the same observer then obtains a subsequent reading of, say, 0.18 g./100 ml. Can he confidently say that a rise in the fibrinogen concentration has occurred? Yes, because the conditions are those of (4) in the Table, assuming that other properties of the patient's plasma, such as the colour, are unaltered: the ratio between his readings is 1.8, which exceeds the tabulated critical ratio of 1.49.

priate turbidity standard to given sample of clotted plasma.

On the basis suggested above, it may be estimated from Fig. 6 that the four turbidity standards to be provided should have optical densities corresponding to about 7.6 units (± 0.3 g./100 ml.), 4.1 units (± 0.2 g./100 ml.), 1.3 units (± 0.1 g. \times 100 ml.), and 0.5 units (± 0.05 g./100 ml.) on the conventional Brown and Kirwan scale used in preparing the standards commercially. The lower three of these fibrinogen values form a two-fold dilution series, so that the ratios between them clearly exceed the highest critical ratio given in Table II. This means that, with these four proposed standard tubes, it is very unlikely that experimental error would lead to an erroneous match in the pathological range.

Discussion

The analysis of variance (Table I) shows four significant variance ratios. Taking first the observer effects: (4, i), the systematic error within observer pairs, simply means that the readings of each individual observer were on the average distinguishable from those of his fellow; and (2, i), the regression on skill, reflects the finding that less "skilled" observers tended to record higher readings than the more "skilled"; but the whole of the observer variation amounts only to an S.D. range of $1.06\times$ to $1/1.06\times$ a given fibrinogen reading. The variation ascribed to different plasma samples (1, v) represents a corresponding S.D. range of $1.08\times$ to $1/1.08\times$; variation from different occasions of testing (representing

the interaction, 3) yields an S.D. range of $1.09\times$ to $1/1.09\times$; and the residual error mean square, (4, ii), gives a range of $1.12\times$ to $1/1.12\times$ for the random variation of a single reading. Thus systematic differences between observers, plasma samples, or occasions of testing are likely to be smaller than the random error.

There is one point of general interest which emerges from a comparison of Figs. 4 and 6. When Fig. 4 (the spectrophotometer readings) is replotted in log-log transformation, the slope of the regression of optical density on fibrinogen concentration is, as would be expected, near unit ν (the fit is linear except at the upper end) whereas the log-log regression obtained with the eye data of Fig. 6 has a significantly higher slope ($b=1.57$). This might be related to the yellow-green colour of plasma, since it is known that the incremental sensitivity of the eye is generally non-linear (Barlow, 1958).

REFERENCES

- Barlow, H. B. (1958). In *Visual Problems of Colour* [National Physical Symposium, No. 8]. H.M.S.O., London.
- Brown, H. C., and Kirwan, E. W. O'G. (1915). *Indian J. med. Res.*, **2**, 763.
- Burstein, M., and Loeb, J. (1952). *Rev. Hémat.*, **7**, 385.
- Ingram, G. I. C. (1952). *Biochem. J.*, **51**, 583.
- Nygaard, K. K. (1941). *Hemorrhagic Diseases*, pp. 137-139. Mosby, St. Louis.
- Sharp, A. A., Howie, B., Biggs, R., and Methuen, D. T. (1958). *Lancet*, **2**, 1309.
- Warner, E. D., Brinkhous, K. M., and Smith, H. P. (1936). *Amer. J. Physiol.*, **114**, 667.