

Fast and slow twitch units in a human muscle

R. E. P. SICA AND A. J. McCOMAS

From the Muscular Dystrophy Research Laboratories, Newcastle General Hospital, Newcastle upon Tyne

SUMMARY A study has been made of the isometric twitches of single motor units in the extensor hallucis brevis (EHB) muscle in man. The twitch contraction times ranged from 35 to 98 msec and the pooled results indicated the presence of at least two types of unit. The recorded twitch tensions also varied considerably (from 2 to 14 g) but were not related to the twitch speeds. The twitch tension developed by the whole EHB muscle depended on the initial length of the muscle and on the age of the subject. The EHB muscle was estimated to contain approximately 56 motor units.

It has recently been shown that individual mammalian motor units can be differentiated in terms of the velocities of their isometric twitches into 'fast' and 'slow' types (Andersen and Sears, 1964; McPhedran, Wuerker, and Henneman, 1965; Wuerker, McPhedran, and Henneman, 1965; Burke, 1967). Furthermore, the twitch characteristics of an entire muscle have been shown to depend on the proportions of fast and slow motor units within that muscle. So far as the situation in man is concerned, it is known that there are also considerable differences in the twitch velocities of muscles and it has been assumed that, as in animals, these reflect the existence of fast and slow units (McComas and Thomas, 1968). In the present paper we have tested this assumption by studying single motor units in the extensor hallucis brevis muscle and have compared their properties with those of the whole muscle. In addition it has been possible to investigate the relationship between the initial length of the muscle and its active tension and to show that this relationship changes with age.

METHODS

SUBJECTS Single motor units were investigated in 31 healthy subjects of both sexes aged between 18 and 36; a further 36 subjects aged between 3 and 94 were used for studies on the whole muscle. The subject rested comfortably on a bed in the supine position; one leg was supported on a sandbag with the foot resting in a specially designed holder (see below). The foot was warmed with an infra-red lamp so that the temperature of the skin overlying the extensor digitorum brevis (EDB) could be maintained at 36° to 38°C.

MECHANICAL RECORDING SYSTEM (Fig. 1) In order to record the isometric twitch of the extensor hallucis brevis

(EHB) the foot was first positioned in the adjustable holder in Fig. 1 which was itself mounted on the universal joint A (Maxiclamp, Spencer Franklin Ltd.). The heel of the subject was fixed by a curved Perspex block (B) which could be moved in the long axis of the holder so that feet of varying sizes could be accommodated. The sole rested against a flat aluminium plate (C) containing a window (D). By sliding a piece of Perspex (E) to one side or the other the great toe of either foot could be made to protrude through the window and to connect with the strain gauge (F). The strain gauge was attached by a wire hook to a stout copper ring round the proximal phalanx of the great toe. The strain gauge was attached to a U-shaped bar (G) which pivoted about an axis coincident with the first metatarsophalangeal joint. This arrangement ensured that force was always exerted on the strain gauge in the same direction irrespective of the position of the U-bar. The initial length or tension of the muscle was varied by moving the U-bar through an angle which could be read from a scale. The strain gauge (Statham type G1-80-350) had a maximum capacity of 2 kg and formed one arm of a Wheatstone bridge energized by a 12 volt d.c. supply; it gave an output of 20 μ V/g. The output from the bridge underwent d.c. amplification (1000 \times) and was displayed on a storage oscilloscope (Hewlett Packard type 141A). The output was also fed to a Biomec 1000 computer (Data Laboratories Ltd.) through a capacity-coupled amplifier with a time-constant of 10 seconds. The smallest signal that could be detected from noise without averaging was 1 g. The resonant frequency of the strain gauge itself was 2.2 kHz; when the toe was attached to the strain gauge the resonant frequency of the system fell to 500 Hz and the corresponding rise time for a suddenly applied force was 0.6 msec.

PROCEDURE FOR STUDIES ON WHOLE MUSCLE The arrangements for stimulating the deep peroneal nerve and for recording evoked potentials from EDB have been described elsewhere (McComas, Fawcett, Campbell, and Sica, 1971). In the present study a single maximal

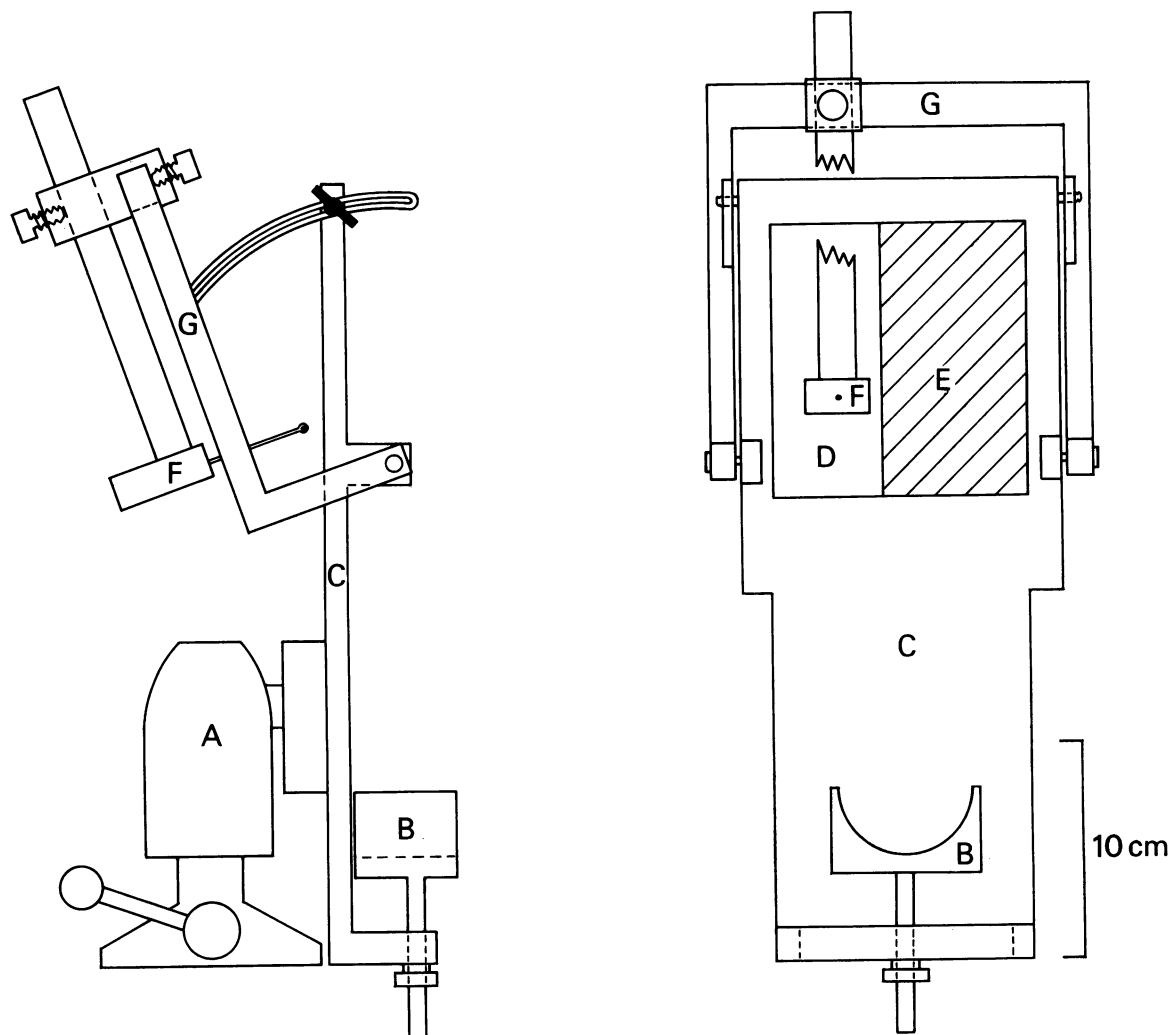

FIG. 1. Adjustable foot holder for EHB twitch experiments, viewed from the side (left) and the front (right). In the latter view the U-bar has been rotated into a plane parallel with that of the base-plate (C). For description of parts and technique of use, see text.

stimulus was delivered to the deep peroneal nerve and the isometric twitch recorded. In early experiments, it was shown that repetitive activity in the motor nerve terminals did not occur, since the responses to single and double stimuli, 200 μ sec. apart, were identical (Fig. 2A; see also Brown and Matthews, 1960). However, if an 'F' wave (Magladery and McDougal, 1950) was present in the electromyogram the twitch was repeated after a delay of 10 seconds (to prevent 'staircase' phenomena, cf. Desmedt and Hainaut, 1968; Slomić, Rosenfalck, and Buchthal, 1968). In some subjects it proved difficult to excite the short extensor maximally without involving

the long extensor as well; in these subjects the stimulating electrodes were moved distally so that the cathode lay over the lateral terminal branch of the deep peroneal nerve at the medial border of EDB. With the cathode in this distal position, it was not possible to monitor the electromyogram and thereby to detect 'F' wave discharges. Instead several isometric twitches were recorded and, if there were differences in the contraction times, the smallest value was selected. The muscles were examined at optimal initial tensions; these were 0.8 to 1.2 kg in subjects between the ages of 16 and 60 and less for younger or older subjects (see Results).

SINGLE UNIT STUDIES In each subject both legs were studied and stimuli were applied first to the deep peroneal nerve and then to its medial terminal branch. The stimuli were delivered every two seconds and their intensities were gradually increased from subthreshold values until all-or-nothing responses could be seen on the oscilloscope. Sixteen twitches were then averaged with a Biomac 1000 computer, together with two 5 msec. calibration pulses each representing 5 g and separated from the other by 120 or 250 msec. All recordings were made at initial tensions of 1.0-1.2 kg.

STATISTICAL TREATMENT Means have been expressed with standard deviations throughout the text. Significances of differences between means were calculated using the Student *t* test.

RESULTS

EFFECT OF PASSIVE STRETCH The relationship between the initial tension imposed upon the EHB muscle and the tension developed during the isometric twitch was investigated in subjects of different ages. Figure 2B shows that in young adults (bottom) a linear relationship between these two factors was maintained until a tension was reached which corresponded to the limit of passive plantar flexion of the great toe. An example of the mechanical response of the muscle with the toe in this extreme position is given in Fig. 2A.

It should be noted that only part of the recorded initial tension in Fig. 2B will have been transmitted to EHB, since the remainder will have been dissipated on other tissues attached to the dorsum of the great toe, especially the tendon of the long extensor muscle. In contrast to young subjects, elderly ones developed an appreciable fraction of the maximum twitch tension when the toe was in the resting position and no passive stretch had been applied. In these subjects a relatively small initial tension was required for the development of maximum twitch tension. If the toe was plantarflexed beyond the position corresponding to this optimal initial tension, the force of the isometric twitch declined (Fig. 2B, top). In middle-aged subjects the optimal initial tension could also be determined and lay close to the limit of passive flexion of the toe (Fig. 2B, middle).

TWITCH CHARACTERISTICS IN SUBJECTS OF DIFFERENT AGES Figure 3(a, b) (see also Fig. 5) shows the contraction and half-relaxation times of maximal isometric muscle twitches in 59 controls aged 3 to 58. In 29 of these subjects the twitch was also examined in the opposite EHB muscle. These paired results were found to be in good agreement; thus the mean discrepancy between the contraction times was $5.2 \pm 7.2\%$, while the corresponding value for the

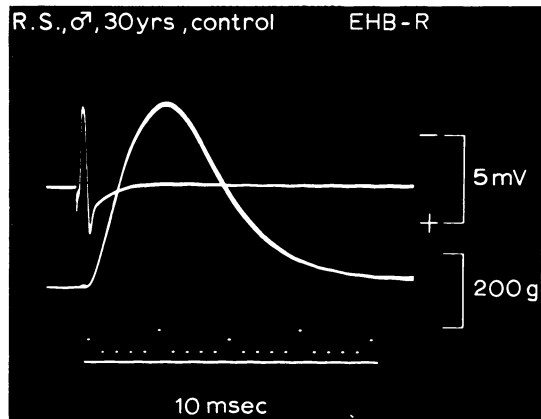

FIG. 2A. Superimposed electrical and mechanical responses of EHB muscle to stimulation of deep peroneal nerve with (1) a single shock, and (2) two shocks separated by 200 μ sec. The close correspondence between the two records indicates absence of 'back-firing' in the motor nerve terminals (see text). In the control subject the active tension was 520 g, while the contraction and half-relaxation times were 57 and 42 msec respectively.

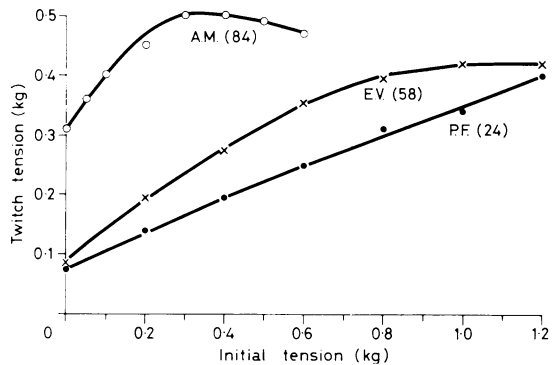

FIG. 2B. Effect of passive muscle stretch on twitch tensions in three subjects at different ages. Curves have been fitted by eye; values in brackets indicate ages of subjects. The resting length of a muscle corresponded to zero initial tension, while plantar flexion of the great toe was complete when 1.0 to 1.2 kg had been applied. The curves represent typical results at the different ages; altogether 26 subjects were investigated.

half-relaxation time was $13.2 \pm 11.1\%$. These values and those of single units (see later) will have been affected by the elasticity of the muscle tendons; thus the twitches recorded from tendon-free muscles would have been faster than those observed in the present study. In Fig. 3(a) it can be seen that, in subjects aged between 3 and 58, there was no correlation between contraction time and age. However,

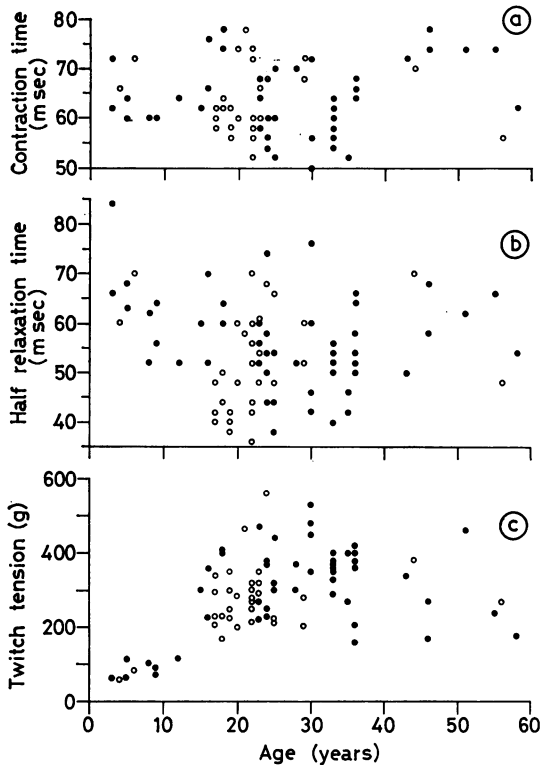

FIG. 3. EHB twitch parameters in subjects at different ages. (a) Contraction time, $r = 0.07$; (b) half-relaxation time, $r = -0.08$; (c) twitch tension. In (b), although the correlation coefficient for the values over the entire age spectrum is small, there is a significant difference between results in children and adults (see text).

although the twitch contraction times of 3 year old children had already attained mature values, the mean half-relaxation time for the 14 children aged 16 or less was still significantly prolonged compared with that of older subjects (62.8 ± 8.8 and 52.5 ± 9.7 msec respectively, $P = <0.001$). Finally, in Fig. 3(c) the maximal twitch tensions of the same subjects are shown. Since the recorded tensions would be affected by the distance between the attachment of the strain gauge to the toe and the metatarsophalangeal joint, care was taken to make this distance as constant as possible in the adults (2-3 cm). From measurements made on a foot post-mortem it appeared that the tension developed by an adult muscle was approximately 3.5 times the recorded value. This reduction in the recorded value was due to the fact that the EHB tendon was attached to the base of the proximal phalanx and, also, that the angle of insertion was oblique. In

the youngest subjects examined the distance of the ring from the metatarsophalangeal joint (1-1.5 cm) was half that in adults; therefore the true tension would probably have been almost twice the recorded value. In the present study the maximum twitch tensions, like the time courses, were found to be similar in the two EHB muscles of control subjects, the mean difference amounting to $21.3 \pm 17.2\%$ (29 subjects). However a small difference was detected in relation to sex, such that the twitches for 26 adult (17 to 58 years) male subjects were slightly stronger than those for 19 females (means 333 ± 91 and 285 ± 81 g respectively, $P = >0.05$).

SINGLE UNIT STUDIES Single motor units were activated by threshold stimulation of motor axons at the ankle and on the dorsum of the foot (see Methods); at each site the stimulus intensity was adjusted until all-or-nothing responses, indicative of single motor unit excitation, were obtained (Fig. 4(c)). In early experiments trouble was experienced with pulse artefacts which were thought to have been transmitted from the dorsalis pedis artery to the overlying EHB tendon. This difficulty was overcome by applying an arterial occlusion cuff at calf level and making single unit recordings within the next two minutes. This short ischaemic period was not thought to affect the single unit responses, since those of the whole muscle were unchanged after a further three minutes of arterial occlusion (Fig. 4 (a, b)). In Fig. 4 (d, e) the averaged responses of two motor units are shown; one of these units had a relatively fast twitch with a contraction time of 42 msec (d) while the other had a slower twitch with a contraction time of 91 msec (e). In some subjects it was possible to record fast and slow twitches of different units within the same muscle.

The variation in contraction times is evident in Fig. 5 where the values for 122 single units have been compared with those for the corresponding 61 EHB muscles (31 subjects). It can be seen that the contraction times of the single units varied from 35 to 98 msec, a range much greater than that of the whole muscle (50 to 78 msec). The single unit results were distributed in two groups with contraction times of 35 to 74 and 78 to 98 msec respectively; the significance of the skewed distribution of values within the first group is considered later (see Discussion).

The twitch tensions of the 122 units investigated were found to range from 2 to 14 g with a mean value of 5.5 g (Fig. 6(a)). Consideration was given to the possibility that a motor unit might exhibit a functional relationship between the speed of its twitch and the amount of tension developed; however this possibility was not supported by the experimental results (Fig. 6(b)).

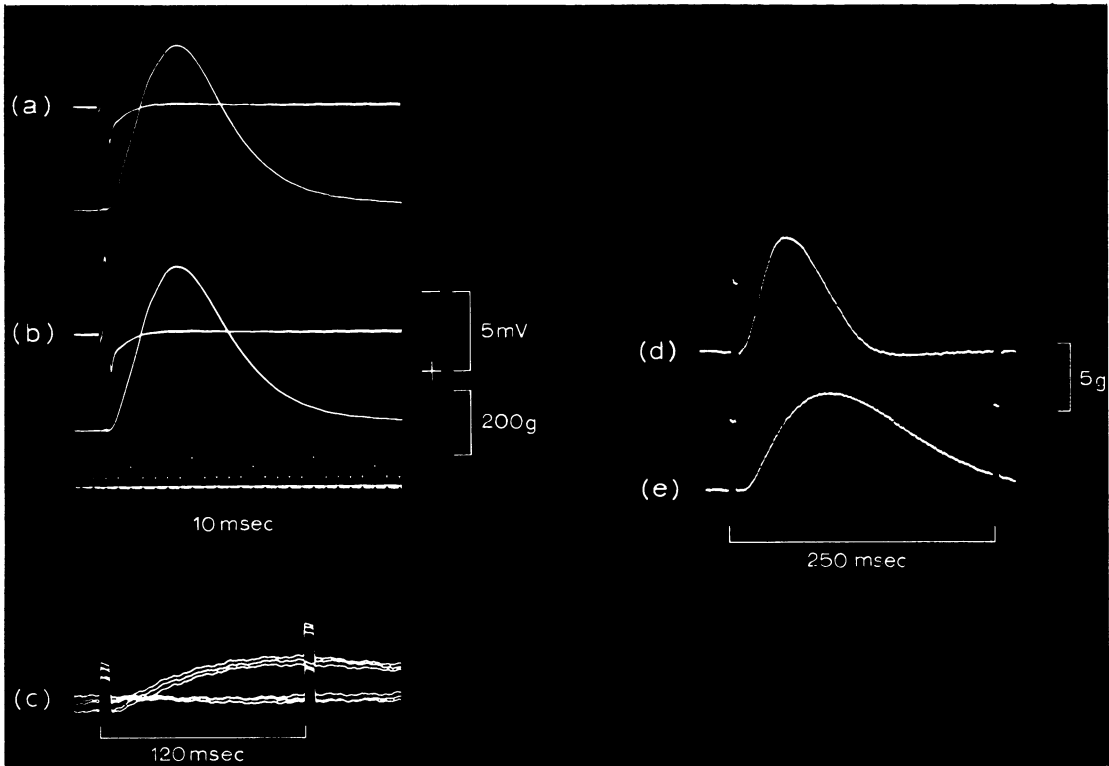

FIG. 4. *EHB twitches; (a) and (b) are twitches of whole muscle before (a) and after (b) five minutes ischaemia. (c) Responses of muscle in a patient to threshold stimulation of deep peroneal nerve; 'all-or-nothing' behaviour suggests excitation of single motor units. (d), (e) Averaged responses of two motor units with different twitch speeds.*

DISCUSSION

It has been known since the time of Ranvier (1873) that mammalian muscles differ considerably in their speeds of contraction and more recently similar observations have been made in man (Buller, Dornhorst, Edwards, Kerr, and Whelan, 1959; McComas and Thomas, 1968; Marsden and Meadows, 1970). Furthermore, studies in animals have shown that these differences result from variable proportions of 'fast' and 'slow' twitch units within muscles (Andersen and Sears, 1964; McPhedran *et al.*, 1965; Wuerker *et al.*, 1965; Burke, 1967). So far as human muscles are concerned, Buchthal and Schmalbruch (1969) have recorded the twitches of bundles of muscle fibres in the biceps and triceps muscles but nothing is known of the properties of individual motor units. In the present study we have found that it is possible to activate motor axons selectively and to record the ensuing motor unit twitches. Since, in

these experiments, the muscle was connected to the strain gauge through the naturally occurring length of tension, the twitches will have been affected by the added elasticity. Nevertheless, although the true twitch speeds and tensions will have been greater than those actually recorded, valid comparisons of the results for different units may still be made, since the lengths of tendon will have been approximately the same in different subjects. Furthermore in each subject it was possible to examine two units within the same muscle and to show that their properties were sometimes strikingly different.

In terms of contraction times, the pooled results fell into two groups. One group of units had relatively 'fast' twitches with contraction times of 35 to 74 msec, while the corresponding values of the 'slow' group were 78 to 98 msec. Similarly, in the cat fast and slow twitch motor units have been identified in the triceps surae (McPhedran *et al.*, 1965; Wuerker *et al.*, 1965; Burke, 1967) and intercostal muscles

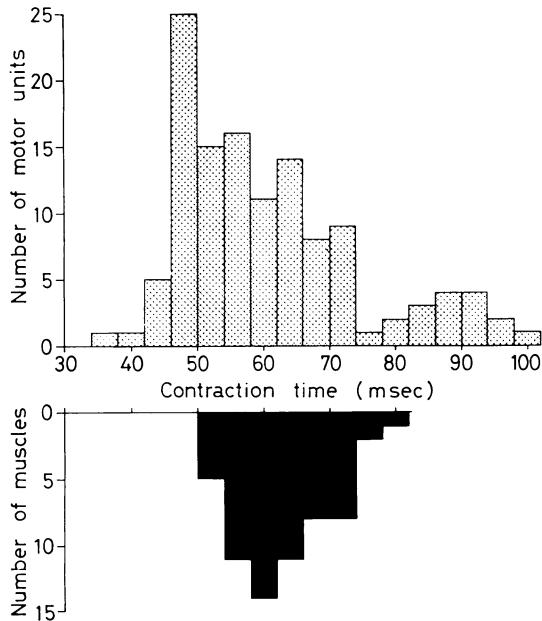

FIG. 5. Contraction times of single EHB motor units (shaded columns) compared with those of the entire muscles (black columns) in the same subjects.

(Andersen and Sears, 1964). In the present study, the contraction times of the two groups of units were rather slower than those reported in the cat, though this may have been due, at least in part, to the elasticity of the EHB tendon (see above). The skewed distribution of 'fast' contraction times in the human EHB was of interest and might have reflected the existence of two populations of units with overlapping twitch speeds. In this context, it is of interest that Stein and Padykula (1962) were able to distinguish clearly three types of muscle fibre in the rat on the basis of their histochemical staining reactions. Although a full histochemical study of the EHB muscle has not yet been undertaken, the myosin ATPase reaction has revealed at least two groups of fibres (Jennekens, 1971).

The mean contraction time of 63.4 ± 8.2 msec for the whole EHB muscle in the present study was in good agreement with the value of 67.1 ± 10.4 msec previously determined for EDB by a different technique (McComas and Thomas, 1968). In this earlier study, the first dorsal interosseus muscle of the hand had a similar twitch speed to EHB, while the frontalis muscle was faster and the lateral gastrocnemius slower. In view of the present findings concerning the properties of single units, it now seems reasonable to suppose that the frontalis muscle is composed mainly of fast twitch units,

while the gastrocnemius contains a large proportion of slow ones. In the EDB muscle itself the single unit results suggest that there are rather more fast than slow twitch units, provided the stimulation technique did not favour excitation of axons belonging to the fast twitch units. Suggestive evidence from another direction also supports this conclusion. Thus, in a 44 year old male patient with a neuropathy affecting type II muscle fibres exclusively, only 55 motor units were estimated in EDB compared with the control mean of 199 (McComas *et al.*, 1971); in this patient the EHB contraction time was 98 msec.

There is, as yet, no evidence in man to indicate the age at which there is completion of the differentiation of muscle fibres in terms of their twitch speeds. It is known that in the newly born kitten,

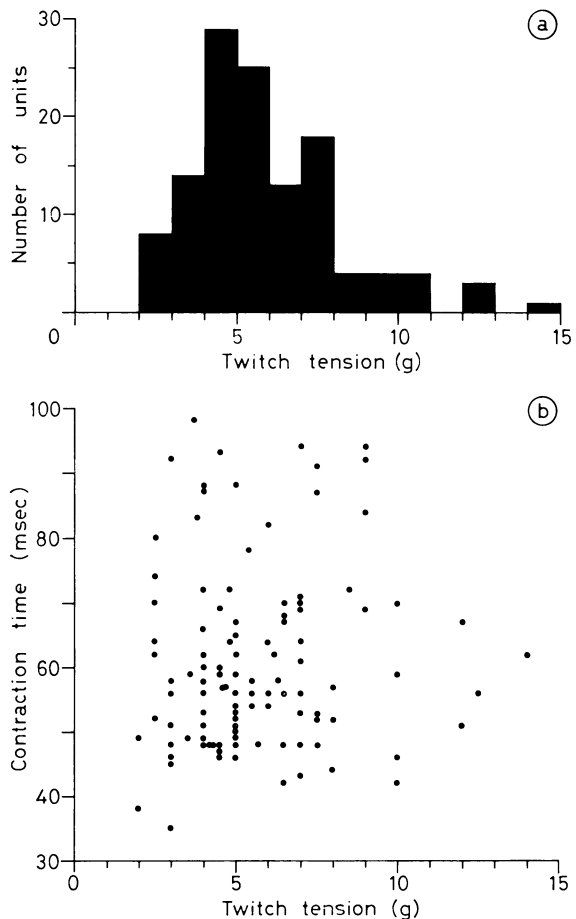

FIG. 6. (a) Twitch tensions of 122 single EHB motor units (mean = 5.5 ± 2.2 g). (b) Relationship between contraction time and tension developed in twitches of single motor units ($r = 0.10$).

for example, the twitches of all muscles are relatively slow and that those of certain muscles become progressively faster during the next few weeks (Buller, Eccles, and Eccles, 1960). The present results suggest that in man this maturation process is well advanced by the age of 3, since the twitch contraction times have already attained adult values.

The recorded values of twitch tension developed by individual motor units are of considerable interest and were found to range from 2 to 14 g. The real tensions would have been approximately 3.5 times greater than this, due to the mechanically disadvantageous insertion of the extensor tendon on to the proximal phalanx of the great toe (see Results). Although the tetanic responses of units were not investigated, it is probable that these would have been at least eight times greater than the twitch tensions; thus, the human adductor pollicis muscle possesses a shorter tendon than the EHB and was found to have twitch/tetanus ratios of 0.125 (Desmedt, 1967) and 0.094 (Slomić *et al.*, 1968). If these considerations are taken into account, it is probable that some units in the human muscle can exert tetanic tensions as great as 400 g. In this study no correlation was observed between the twitch tension of a unit and its speed of contraction. In contrast, Burke (1967) found that, in the cat, slow units exerted relatively small tensions, while those of fast units varied considerably.

The twitch tensions of motor units are of interest in another respect, since they have enabled an estimate to be made of the number of units in EHB. Thus the mean motor unit twitch tension was 5.5 g, while that of the entire EHB was 313 g, suggesting that approximately 56 units were present. However the extensor hallucis brevis (EHB) is only one of four subdivisions of the extensor digitorum brevis (EDB) muscle belly. If each subdivision contained the same number of units, and if each unit exerted tension on only a single tendon, then the total number of units in EDB would be approximately 224—that is, 56×4 . This result is in good agreement with the value of 199 ± 60 estimated by another physiological technique (McComas *et al.*, 1971).

The influence of the naturally occurring length of tendon on the twitch amplitude has been mentioned already (see above). The results of this study suggest that, during ageing, either this influence becomes less or else some other structural change takes place within the muscle belly itself. Thus it was observed that, when the muscle was at its resting length, a much larger fraction of the maximum twitch tension could be exerted in an elderly subject than in a young one. This difference might be related, at least in part, to the loss of elasticity in tissues which is known to occur with ageing. The present results

are of interest for another reason, since they show that the EHB muscle of a young subject is unable to develop its full twitch tension even when maximally stretched by plantar flexion of the great toe. This finding suggests that the correspondence generally thought to exist between the 'optimum' and 'resting' lengths of a muscle *in situ* is not present for all muscles, at least in young subjects.

We wish to acknowledge the generous help of Dr. M. J. Campbell and Mr. P. R. W. Fawcett during some of the early experiments; in addition, we are greatly indebted to Mr. C. Wallace, Mr. T. Blogg, and Mr. L. Smith for technical services and to Mrs. Y. Chisholm for secretarial assistance. Financial support was received from the Muscular Dystrophy Group of Great Britain, the Muscular Dystrophy Associations of America Inc. and the Medical Research Council. One of us (R.E.P.S.) held a British Council Scholarship.

REFERENCES

- Anderson, P., and Sears, T. A. (1964). The mechanical properties and innervation of fast and slow motor units in the intercostal muscles of the cat. *J. Physiol. (Lond.)*, **173**, 114-129.
- Buchthal, F., and Schmalbruch, H. (1969). Spectrum of contraction times of different fibre bundles in the brachial biceps and triceps muscles of man. *Nature (Lond.)*, **222**, 89.
- Brown, M. C., and Matthews, P. B. C. (1960). The effect on a muscle twitch of the back response of its motor nerve fibres. *J. Physiol. (Lond.)*, **150**, 332-346.
- Buller, A. J., Dornhorst, A. C., Edwards, R., Kerr, D., and Whelan, R. F. (1959). Fast and slow muscles in mammals. *Nature (Lond.)*, **183**, 1516-1517.
- Buller, A. J., Eccles, J. C., and Eccles, R. M. (1960). Differentiation of fast and slow muscles in the cat hind limb. *J. Physiol. (Lond.)*, **150**, 399-416.
- Burke, R. E. (1967). Motor unit types of cat triceps surae muscle. *J. Physiol. (Lond.)*, **193**, 141-160.
- Desmedt, J. E. (1967). The isometric twitch of human muscle in the normal and the dystrophic states. In *Exploratory Concepts in Muscular Dystrophy and Related Disorders*, pp. 224-231. Edited by A. T. Milhorat. Excerpta Medica Foundation: Amsterdam.
- Desmedt, J. E., and Hainaut, K. (1968). Kinetics of myofibril activation in potentiated contraction: staircase phenomenon in human skeletal muscle. *Nature (Lond.)*, **217**, 529-532.
- Jennekens, F. G. I. (1971). *In preparation*.
- Magladery, J. W., and McDougal, D. B. Jr. (1950). Electrophysiological studies of nerve and reflex activity in normal man. I. Identification of certain reflexes in the electromyogram and the conduction velocity of peripheral nerve fibres. *Bull. Johns. Hopk. Hosp.*, **86**, 265-290.
- Marsden, C. D., and Meadows, J. C. (1970). The effect of adrenaline on the contraction of human muscle. *J. Physiol. (Lond.)*, **207**, 429-448.
- McComas, A. J., Fawcett, P. R. W., Campbell, M. J., and Sica, R. E. P. (1970). Electrophysiological estimation of the number of motor units within a human muscle. *J. Neurol. Neurosurg., Psychiat.*, **34**, 121-131.
- McComas, A. J., and Thomas, H. C. (1968). Fast and slow twitch muscles in man. *J. neurol. Sci.*, **7**, 301-307.

- McPhedran, A. M., Wuerker, R. B., and Henneman, E. (1965). Properties of motor units in a homogeneous red muscle (soleus) of the cat. *J. Neurophysiol.*, **28**, 71-84.
- Ranvier, L. (1873). Propriétés et structures différentes des muscles rouges et des muscles blancs, chez les lapins et chez les raies. *C.R. Acad. Sci. (Paris)*, **77**, 1030-1034.
- Slomić, A., Rosenfalck, A., and Buchthal, F. (1968). Electrical and mechanical responses of normal and myasthenic muscle, with particular reference to the staircase phenomenon. *Brain Res.*, **10**, 1-78 (special issue).
- Stein, J. M., and Padykula, H. A. (1962). Histochemical classification of individual skeletal muscle fibres of the rat. *Amer. J. Anat.*, **110**, 103-124.
- Wuerker, R. B., McPhedran, A. M., and Henneman, E. (1965). Properties of motor units in a heterogeneous pale muscle (M. gastrocnemius) of the cat. *J. Neurophysiol.*, **28**, 85-99.

Notice

We regret that, because of the recent postal strike, this issue is smaller than usual.