

## Resolvins and omega three polyunsaturated fatty acids: Clinical implications in inflammatory diseases and cancer

Kazuki Moro, Masayuki Nagahashi, Rajesh Ramanathan, Kazuaki Takabe, Toshifumi Wakai

Kazuki Moro, Masayuki Nagahashi, Toshifumi Wakai, Division of Digestive and General Surgery, Niigata University Graduate School of Medical and Dental Sciences, Niigata City 951-8510, Japan

Rajesh Ramanathan, Kazuaki Takabe, Division of Surgical Oncology, Department of Surgery, Virginia Commonwealth University School of Medicine and the Massey Cancer Center, Richmond, VA 23298-0011, United States

**Author contributions:** Moro K, Nagahashi M and Takabe K contributed to this work, generated the figures and wrote the manuscript; Ramanathan R proofread English writing; Wakai T designed the aim of the editorial.

**Supported by** The Japan Society for the Promotion of Science (JSPS) Grant-in-Aid for Scientific Research, Nos. 15H05676 and 15K15471 for Nagahashi M and No. 15H04927 for Wakai T; Nagahashi M is supported by the Uehara Memorial Foundation, Nakayama Cancer Research Institute, Takeda Science Foundation, and Tsukada Medical Foundation; Takabe K is supported by NIH/NCI, No. R01CA160688; Takabe K is supported by Susan G. Komen Investigator Initiated Research, No. IIR12222224; Moro K and Nagahashi M are supported by Tohoku Cancer Professional Training Promotion Plan.

**Conflict-of-interest statement:** The authors declare no conflicts of interest in association with the present study.

**Open-Access:** This article is an open-access article which was selected by an in-house editor and fully peer-reviewed by external reviewers. It is distributed in accordance with the Creative Commons Attribution Non Commercial (CC BY-NC 4.0) license, which permits others to distribute, remix, adapt, build upon this work non-commercially, and license their derivative works on different terms, provided the original work is properly cited and the use is non-commercial. See: <http://creativecommons.org/licenses/by-nc/4.0/>

**Correspondence to:** Masayuki Nagahashi, MD, PhD, Associate Professor, Division of Digestive and General Surgery, Niigata University Graduate School of Medical and Dental Sciences, 1-757 Asahimachi-dori, Chuo-ku, Niigata City 951-8510, Japan. [mnahashi@med.niigata-u.ac.jp](mailto:mnahashi@med.niigata-u.ac.jp)  
Telephone: +81-25-2272228

Fax: +81-25-2270779

Received: January 7, 2016  
Peer-review started: January 9, 2016  
First decision: March 1, 2016  
Revised: March 14, 2016  
Accepted: April 5, 2016  
Article in press: April 6, 2016  
Published online: July 16, 2016

### Abstract

Inflammation is a central process in several disorders and contributes to cancer progression. Inflammation involves a complex cascade of pro-inflammatory and anti-inflammatory signaling events with protein and lipid mediators. Recent advances in lipid detection have revealed the importance of lipid mediators in inflammation. Omega three polyunsaturated fatty acids ( $\omega$ -3 PUFA) are found naturally in fish oil and have been extensively studied in multiple inflammatory diseases with improved outcomes. Resolvins are thought to be the active metabolites of  $\omega$ -3 PUFA, and are responsible for facilitating the resolving phase of acute inflammation. Clinically, resolvins have been associated with resolution of acute kidney injury and acute lung injury, micro and macro vascular response to injury, and inhibition of microglia-activated inflammation in neurodegenerative disorders. In addition to inflammatory diseases,  $\omega$ -3 PUFA and resolvins appear to modulate cancer progression.  $\omega$ -3 PUFA intake has been associated with reduced inflammation in colorectal cancer, and favorable phenotype in breast cancer. Resolvins offer promising therapeutic potential as they may modulate inflammation with minimal side-effects, in contrast to currently available anti-inflammatory medications. This review describes the roles of  $\omega$ -3 PUFA and resolvins in the inflammatory cascade, various inflammatory diseases, and specific cancers. Additionally, it will discuss the clinical therapeutic potential of resolvins as

targets in inflammatory diseases and cancers.

**Key words:** Anti-inflammatory lipid mediators; Resolvin; Omega three polyunsaturated fatty acids; Inflammatory diseases; Cancer

© **The Author(s) 2016.** Published by Baishideng Publishing Group Inc. All rights reserved.

**Core tip:** There is general consensus that inflammation closely relates not only with inflammatory diseases, but also cancer. Recently several lipid mediators, such as resolvins, were found to be pro-resolving mediators that facilitate the resolution of acute inflammation and help to prevent excessive inflammation. Thus, it is speculated that resolvins may have anti-inflammatory therapeutic potential. Here we review the roles of resolvins in inflammation and inflammatory diseases and explore the potential of lipid mediators for clinical application.

Moro K, Nagahashi M, Ramanathan R, Takabe K, Wakai T. Resolvins and omega three polyunsaturated fatty acids: Clinical implications in inflammatory diseases and cancer. *World J Clin Cases* 2016; 4(7): 155-164 Available from: URL: <http://www.wjgnet.com/2307-8960/full/v4/i7/155.htm> DOI: <http://dx.doi.org/10.12998/wjcc.v4.i7.155>

## INTRODUCTION

Inflammation is known to be involved in a multitude of disease processes. For instance, inflammation evokes not only inflammatory diseases such as gastroenteritis and hepatitis, but is also involved in the pathogenesis of obesity<sup>[1]</sup>, diabetes mellitus<sup>[2]</sup>, and neurological diseases<sup>[3]</sup>. Pro-inflammatory mediators, such as tumor necrosis factor (TNF) from fat cells causes inflammation in obesity, tumorigenesis and progression of cancer<sup>[4-7]</sup>. Recently, the mechanism of inflammation in these disease processes have been investigated and several key families of inflammatory mediators have been identified<sup>[8]</sup>.

Key families of mediators include protein mediators, such as TNF and interleukins (IL)<sup>[9]</sup>, and eicosanoid mediators, such as prostaglandins (PG)<sup>[10]</sup> and thromboxanes<sup>[11]</sup>, which function at the cellular level<sup>[12]</sup>. Another key family of lipid mediators are eicosapentaenoic acid (EPA) and docosahexaenoic acid (DHA) from fish oil<sup>[13]</sup>, which are signaling molecules made of lipids that regulate inflammation differently from eicosanoids and protein mediators. It has been suggested that the anti-inflammatory effects of EPA or DHA are due to their metabolite, resolvins<sup>[14,15]</sup>. Resolvins actively facilitate the resolving phase of acute inflammation, as opposed to classic protein mediators which mainly act during the onset phase of inflammation<sup>[8]</sup>. It is expected that controlling these lipid mediators will possibly prevent and/or provide

treatment options for diseases related to inflammation. Herein, we review the roles of resolvins in inflammation and related diseases, and explore the potential of the lipid mediators for future clinical, therapeutic application.

## AN EMERGING ROLE OF PRO-RESOLVING LIPID MEDIATORS IN INFLAMMATION

Lipid mediators are bioactive lipids produced locally by specific biosynthetic processes evoked by extracellular stimuli. In response to stimuli, they are exported to the extracellular space and bind to their specific G protein-coupled receptors on the target cells to transmit signals. They are then sequestered rapidly through specific enzymatic and non-enzymatic processes<sup>[16]</sup>. Since lipid mediators work in autocrine, paracrine, and endocrine manners, they can be regarded as local hormones or autacoids<sup>[17]</sup>. Lipid mediators regulate multiple cellular functions including cell proliferation, migration, and survival. They are related to multiple pathological conditions including autoimmune diseases, inflammatory diseases, and cancer. Lipid mediators are produced on demand, and occasionally stored as precursors to facilitate rapid mobilization when required. In the next paragraphs, the role and pathophysiology of lipid mediators in acute and chronic inflammation will be described.

There are two phases in acute inflammation: The onset phase, and the resolving phase<sup>[8]</sup> (Figure 1). Some lipid mediators, such as eicosanoids, play important roles in both phases (Figure 2). During the onset phase, lipid mediators such as PG and leukotrienes (LT) function as pro-inflammatory mediators, in addition to cytokines such as TNF and IL. After tissue injury or trauma, PGE2 and LTB4 increase vascular permeability, initiate infiltration of the neutrophils into the injured tissue, and remove dead cells. Further, it has been revealed that sphingolipids, such as sphingosine-1-phosphate, and lysophosphatidic acid, also play a critical role as pro-inflammatory lipid mediators in the onset phase of acute inflammation<sup>[18-22]</sup>. Although the role of pro-inflammatory lipid mediators during the onset phase has been well studied, the mechanisms of pro-resolving lipid mediators in the resolving phase of acute inflammation has not been as well elucidated.

The classic model of resolution of acute inflammation includes sequestration of pro-inflammatory cytokines, clearance of neutrophils from epithelial surfaces, phagocytosis of apoptotic neutrophils, and removal of inflammatory debris and microbial invaders<sup>[23]</sup>. This has been traditionally considered a passive process that limits excessive infiltration of neutrophils, however, it has been recently discovered that lipid mediators actively facilitate the resolution of acute inflammation to prevent excessive inflammation<sup>[24,25]</sup>. At the height of the inflammatory response, pro-resolving lipid mediators are produced, and promote resolution of the inflammation<sup>[8]</sup>. Pro-resolving lipid mediators stimulate

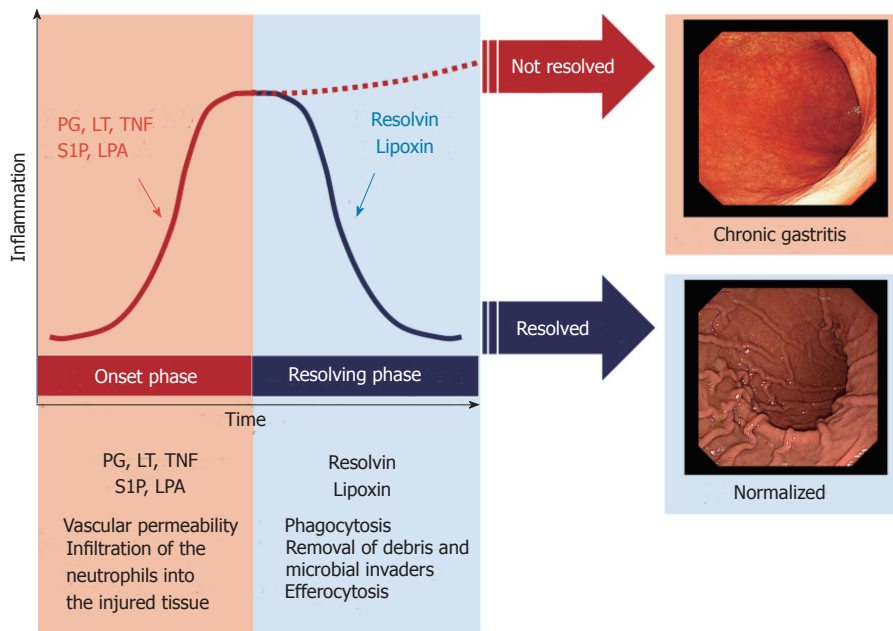

**Figure 1** A course of acute inflammation with two phases: The onset phase and the resolving phase. Acute inflammation is caused by stresses such as tissue injuries, microbial infections or surgical intervention. There are two phases in acute inflammation: The onset phase, and the resolving phase. Usually, the inflammation is resolved through these phases. When the inflammation is not resolved, it develops diseases with chronic inflammation. For instance, inflammation in stomach caused by microbial infections follow a course of the two phases in acute inflammation. When the acute inflammation is not resolved through the resolving phase, it develops chronic gastritis. PG: Prostaglandins; LT: Leukotrienes; TNF: Tumor necrosis factor; S1P: Sphingosine-1-phosphate; LPA: Lysophosphatidic acid.

macrophage switching from the pro-inflammatory M1 phenotype to the anti-inflammatory M2 phenotype in the latter part of onset phase<sup>[26]</sup>. During the transition from the onset phase toward the resolving phase, representative pro-resolving lipid mediators, such as lipoxin and resolvins, actively stimulate the recruitment of non-inflammatory monocytes. Lipoxin is a metabolite of the arachidonic acid pathway and plays a vital role in reducing excessive tissue injury and chronic inflammation. In the resolving phase, both resolvin and lipoxin play important roles in phagocytosis, removal of debris and microbial invaders, and efferocytosis (Figure 1). Efferocytosis is the process where neutrophils and dead cells presenting for apoptosis are taken into the phagocytes and removed from the site of inflammation<sup>[27]</sup>. When efferocytosis does not work well, neutrophils are not dealt with adequately and they release inflammatory cytokines. Lack of efferocytosis results in prolonged chronic inflammation (Figure 1)<sup>[28,29]</sup>. Considering that resolvins promote efferocytosis in the resolving phase, and it is reasonable to assume that the lack of resolvin results in prolonged inflammation. Indeed, it has been reported that supplementation with pro-resolving mediators reduces the development of chronic inflammation in animal studies. Taken together, it is suggested that resolvins have the clinical potential to slow the progression of chronic diseases.

## HISTORY OF $\omega$ -3 POLYUNSATURATED FATTY ACID AND RESOLVINS

Increasing evidence has revealed that acute and

chronic inflammation are involved in the pathogenesis of many diseases, such as vasculopathies<sup>[30]</sup>, metabolic syndrome<sup>[31]</sup>, neurological diseases<sup>[32]</sup>, and cancer<sup>[7]</sup>. Elucidation of the mechanism of pro-resolving mediators in these diseases may provide new insights into treatment options<sup>[33-35]</sup>. Among the previously-discovered pro-resolving lipid mediators, resolvins have been shown to play a central anti-inflammatory role<sup>[36]</sup>.

In the 1970s, an epidemiological study revealed the benefits of dietary  $\omega$ -3 polyunsaturated fatty acids (PUFA) for the first time, whereby coronary atherosclerosis occurred far less among Greenland Eskimos, who consume more fish oil, than people in industrialized countries who do not consume as much fish oil<sup>[37]</sup>. Although  $\omega$ -3 PUFA has long been thought to have anti-inflammatory properties, the molecular mechanism of how they resolve inflammation is unclear. Dr. Serhan is credited with first discovering a group of new compounds that were generated in resolving inflammatory exudates in murine air pouches with  $\omega$ -3 PUFA. He hypothesized that those new compounds play an active role in the process of resolving inflammation through  $\omega$ -3 PUFA. Indeed, these new compounds proved to have the potential to inhibit human leukocyte migration and infiltration *in vivo*<sup>[15]</sup>. In 2000, Dr. Serhan identified a new lipid mediator derived from  $\omega$ -3 PUFA that promoted the resolving phase of acute inflammation and it was later named "resolvin"<sup>[14]</sup>. Recently advances in mass spectrometry have enabled accurate quantification of the mass amounts of lipid mediators, including resolvins, and gradually have demonstrated their function.

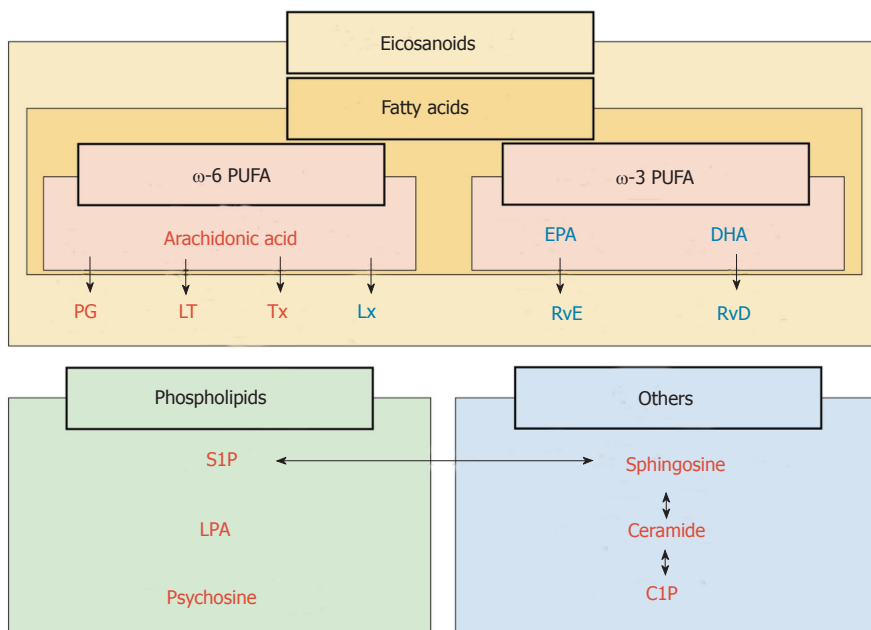

**Figure 2 Classification of lipid mediators of inflammation.** Lipid mediators are classified with fatty acids, phospholipids and others. Among the fatty acids, eicosanoids are the derivatives of polyunsaturated fatty acids (PUFA), which are present in dietary sources, such as fish oil ( $\omega$ -3 PUFA) and vegetable oil ( $\omega$ -6 PUFA).  $\omega$ -6 PUFA generates prostaglandins (PG), leukotrienes (LT), thromboxanes (Tx) and lipoxins (Lx). Resolvin originates from eicosapentaenoic acid (EPA) and docosahexaenoic acid (DHA), which are components of  $\omega$ -3 PUFA. Resolvin derived from EPA and DHA are termed resolvin E (RvE) and resolvin D (RvD) series, respectively, both of which act as pro-resolving mediators. Phospholipids including sphingosine-1-phosphate (S1P) and lysophosphatidic acid (LPA) and others including ceramides and ceramide-1-phosphate (C1P) usually act as pro-inflammatory mediators. Red: Pro-inflammatory mediators; Blue: Pro-resolving mediators.

PUFA are present in various dietary sources, such as fish oil ( $\omega$ -3 PUFA) and vegetable oil ( $\omega$ -6 PUFA).  $\omega$ -6 PUFA generates arachidonic acids which are the precursors to PG, LT and lipoxin.  $\omega$ -3 PUFA generates EPA and DHA. Resolvins derived from EPA and DHA are termed resolvin E (RvE) and resolvin D (RvD) series, respectively<sup>[14]</sup> (Figure 2). Resolvins are biosynthesized from  $\omega$ -3 PUFA by specific enzymes including lipoxygenase (LOX). RvD1 is biosynthesized *via* 15/5-lipoxygenase (LO) within vascular endothelial cells. To date, six members of this family has been identified (RvD1-6)<sup>[38]</sup>. Moreover RvD is also biosynthesized *via* aspirin-acetylated COX-2, and we call aspirin triggered RvD (AT-RvD). Although the structures and biosynthetic routes of RvDs are identified, their physiological functions remain to be clarified.

RvEs are endogenously produced during endothelial cell-leukocyte interaction. The complete stereochemistry revealed that the first member of this family, RvE1, has multiple biosynthetic routes. Within vascular endothelial cells, aspirin-acetylated COX-2 converts EPA into 18R-hydro (peroxy)-eicosapentaenoic acid (HEPE) through the enzymatic reaction of 5-LOX. HEPE is rapidly taken up by activated leukocytes and further metabolized into RvE1<sup>[39]</sup>. RvE1 is also produced through an aspirin-independent pathway *via* cytochrome P450-driven oxygenation of EPA<sup>[40]</sup>. RvE2 is also biosynthesized in endothelial cells like RvE1. RvE1 and RvE2 are mainly biosynthesized in neutrophils, and react with 5-LOX, which is known to increase during the onset phase of acute inflammation<sup>[39,41]</sup>.

RvE3 is generated from 18-HEPE *via* the 12/15-LOX pathway. A recent study demonstrated that eosinophils contribute to the biosynthesis of RvE3. RvE3 inhibited neutrophil chemotaxis *in vitro* at low nanomolar concentrations. It is, therefore, intriguing to consider RvE3 as a potential endogenous anti-inflammatory compound to protect against an aberrant or uncontrolled innate inflammatory response<sup>[42]</sup> (Figure 3).

## LIPID MEDIATORS IN INFLAMMATORY DISEASE

It has been shown that excessive inflammation contributes to widely occurring human diseases. Various kinds of natural foods such as fish oil and plants contain  $\omega$ -3 PUFA, and many studies have been conducted to examine its benefits on human health. Many clinical studies related to  $\omega$ -3 PUFA have been conducted since the Greenland Eskimos study in 1970s, and have revealed that it improves various disease conditions, especially those with acute and chronic inflammation. Although it has been revealed that  $\omega$ -3 PUFA displays anti-inflammatory effects, the underlying mechanisms were unknown. Later, it has been discovered that resolvins play a pivotal role in resolving inflammation through  $\omega$ -3 PUFA. Although there have only been a small number of studies testing the effect of resolvins in humans, it remains very promising considering previous positive results with  $\omega$ -3 PUFA<sup>[43-46]</sup>. Further, recent advances in mass spectrometry have enabled quantification of absolute amounts of specific lipid



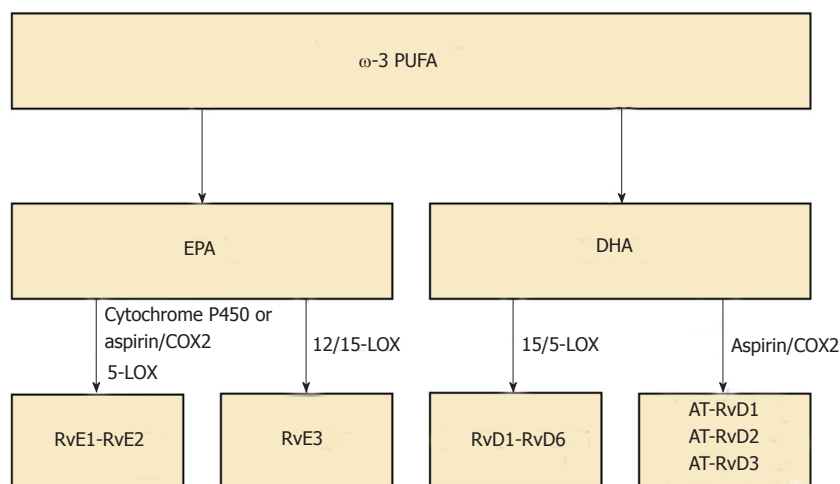

**Figure 3 Classification of resolvins.** Resolvins are biosynthesized from  $\omega$ -3 polyunsaturated fatty acids (PUFA) by specific enzymes including lipoxygenase (LOX). Resolvin E (RvE) is endogenously produced from eicosapentaenoic acid (EPA) during endothelial cell-leukocyte interaction. RvE1 and RvE2 are biosynthesized through two different pathways via cytochrome P450-driven oxygenation of EPA or via aspirin-acetylated cyclooxygenase 2 (COX-2). RvE3 is generated via the 12/15-LOX pathway. In addition, resolvin D (RvD) is biosynthesized from docosahexaenoic acid (DHA) via 15/5-LOX within vascular endothelial cells. To date, six members of this family has been identified RvD1-6. Also, RvD is also biosynthesized via aspirin-acetylated COX-2, and we call aspirin triggered RvD (AT-RvD).

mediators<sup>[36]</sup>. This has enabled measuring the amount of specific resolvins in human tissues, such as blood or sputum at different time points in inflammatory conditions. These studies have revealed the importance of resolvins in the inflammatory disease processes in the human body. In the following paragraphs, representative studies describing pro-resolving lipid mediators in various human diseases will be reviewed.

Wang *et al.*<sup>[43]</sup> reported a randomized clinical trial, in which 64 adult patients with gastrointestinal diseases, such as gastric cancer and colonic cancer, were randomly assigned to total parenteral nutrition with either  $\omega$ -3 PUFA enriched emulsion or medium-chain triacylglycerols/long-chain triacylglycerols for 5 d after surgery. They found that the  $\omega$ -3 PUFA enriched emulsion significantly increased the concentrations of pre-resolving mediators leukotriene B5 and B4, and significantly decreased the inflammatory cytokines IL-6, TNF- $\alpha$ , and nuclear factor- $\kappa$ B in plasma. This result suggests that  $\omega$ -3 PUFA in total parenteral nutrition has an anti-inflammatory effect in patients with gastrointestinal diseases<sup>[43]</sup>.

Peritonitis is defined as an inflammation of the peritoneum, commonly due to intraperitoneal bacterial or fungal infection associated with bowel perforation. Spite *et al.*<sup>[44]</sup> demonstrated that intraperitoneal administration of RvD2 improved survival of peritonitis in mice by enhancing bacterial clearance without immune suppression in a cecal ligation and puncture-initiated sepsis model.

Tomio *et al.*<sup>[46]</sup> investigated the effect of dietary  $\omega$ -3 PUFA in inflammation by monitoring cystic endometriotic lesions in fat-1 mice, which are genetically modified to convert  $\omega$ -6 PUFA into  $\omega$ -3 PUFA<sup>[45]</sup>. Endometriosis is an inflammatory disease of the female reproductive tract associated with ectopic implants of endometrial tissue. The number and weight of cystic endometriotic lesions

in fat-1 mice two weeks after inoculation were less than half to those of controls where all of them were fed a special diet high in  $\omega$ -6 PUFA and low in  $\omega$ -3 PUFA. They concluded that  $\omega$ -3 PUFAs protects against the development of endometriosis<sup>[46]</sup>.

Resolvins have been shown to demonstrate a protective effect in kidney diseases. Zivkovic *et al.*<sup>[47]</sup> reported serum lipid mediator levels analyzed by mass spectrometer in IgA nephropathy patients who were supplemented with either fish oil or corn oil placebo. IgA nephropathy patients supplemented with fish oil showed lower production of arachidonic acid metabolites in serum and improved proteinuria<sup>[47]</sup>. Furthermore, Zhang *et al.*<sup>[48]</sup> found that RvD1 is protective against Adriamycin-induced podocyte damage in a mouse model of acute kidney injury.

Acute lung injury and other lung diseases lack effective curative treatments. Cystic fibrosis (CF) is an autosomal recessive disease that causes chronic inflammation in the lung due to chronic obstructive pulmonary disease and frequent lung infections. Yang *et al.*<sup>[49]</sup> measured RvE1 in sputum from CF patients using mass spectrometry. Patients with detectable levels of the RvE1 in sputum demonstrated better lung function compared to patients with undetectable levels, indicating that higher concentration of the RvE1 in sputum is associated with less inflammation in the lungs of CF patients<sup>[49]</sup>. Wang *et al.*<sup>[50]</sup> found that pretreatment with RvD1 reduced the lung damage in a mouse model of acute lung injury and acute respiratory distress syndrome induced by oxidative stress of lipopolysaccharide by decreasing the recruitment of neutrophils and stimulating their apoptosis. These clinical, translational studies suggest the important role of the lipid mediators in these diseases.

The role of resolvins has been assessed not only in acute, but also in chronic inflammatory diseases.

The complications of diabetes mellitus involve chronic inflammation-mediated micro- and macro-vascular damage, disruption of lipid metabolism, and abnormalities of neutrophil-mediated events. Herrera *et al.*<sup>[51]</sup> used transgenic mice over-expressing the human RvE1 receptor in type 2 diabetes mice and investigated the impact of RvE1 on the phagocytosis of *Porphyromonas gingivalis* in type 2 diabetes. They found that RvE1 increased the neutrophil count and that phagocytosis of *Porphyromonas gingivalis* was significantly increased in mice over-expressing the human RvE1 receptor<sup>[51]</sup>. Atherosclerosis is another chronic inflammatory disease of the vascular wall. Miyahara *et al.*<sup>[52]</sup> utilized the balloon induced arterial injury in rabbits and found that RvDs broadly reduced vascular smooth muscle cell responses to vascular injury.

Amyotrophic lateral sclerosis (ALS), Parkinson's, Alzheimer's, and Huntington's disease are neurodegenerative diseases associated with progressive loss of structure and/or function of neurons. Xu *et al.*<sup>[32]</sup> found that RvD1 inhibited the pro-inflammatory responses of inflammatory mediators induced by LPS in murine microglia. This is significant because the inhibition of microglia-activated inflammation is an accepted potential treatment strategy for these diseases<sup>[32]</sup>.

There has been an interest in whether the increasing dietary intake of  $\omega$ -3 PUFA may improve cognitive function. Hashimoto *et al.*<sup>[53]</sup> divided healthy people over 55 years old in two groups; people taking DHA 1.7 g and EPA 0.4 g, and people consuming olive oil. The four-year cohort study identified a delay in deterioration of cognitive function among people in the DHA and EPA group, with higher scores in MMSE (mini-mental state examination). This indicated that taking  $\omega$ -3 PUFA may slow the deterioration of cognitive function in aging<sup>[53]</sup>. However, Quinn *et al.*<sup>[54]</sup> subsequently divided patients with Alzheimer disease into two groups; the group of patients taking DHA 2 g and those taking corn oil. After an 18 mo double-blinded follow-up, they concluded that supplementation with DHA compared with placebo did not slow the rate of cognitive and functional decline in patients with mild to moderate Alzheimer disease<sup>[54]</sup>. Though the effect of  $\omega$ -3 PUFA in cognitive function remains unclear, the mechanism of  $\omega$ -3 PUFA likely includes its anti-inflammatory action.

## LIPID MEDIATORS IN CANCER

Cancer is one of the leading causes of death worldwide, accounting for 8.2 million deaths in 2012. Inflammation is involved with cancer progression, especially among certain types of cancer caused by viral infection<sup>[27,55]</sup>. Such examples include hepatitis C virus and liver cancer<sup>[56,57]</sup>, human papillomavirus and cervical cancer of the uterus<sup>[58,59]</sup>, *Helicobacter pylori* and gastric cancer<sup>[60,61]</sup>, and schistosomiasis infection and bladder cancer<sup>[62,63]</sup>. Further, some autoimmune conditions that cause inflammation can lead to cancer, such as autoimmune hepatitis and liver cancer<sup>[64]</sup>. Chronic

inflammation can also lead to cancer, such as reflux esophagitis and esophageal cancer<sup>[65,66]</sup>, anal fistula and fistula cancer<sup>[67]</sup>, and inflammatory bowel disease and colorectal cancer (CRC)<sup>[68]</sup>.

In CRC patients, dietary  $\omega$ -3 PUFA levels have been associated with reduced blood levels of IL-6 and increased albumin. Moreover, in CRC patients undergoing chemotherapy, supplementation with dietary 0.6 g/d of EPA + DHA for 9 wk reduced C-reactive protein levels, indicating less systemic inflammation. Furthermore, it has been shown that the level of total  $\omega$ -3 PUFA is lower in the serum of CRC patients compared to healthy controls<sup>[69]</sup>.

In breast cancer,  $\omega$ -3 PUFA is receiving a lot of attention. Leslie *et al.*<sup>[70]</sup> studied whether  $\omega$ -3 PUFA reduces breast tumors in female transgenic mice. They fed mice a fish oil- containing  $\omega$ -3 PUFA diet for 20 wk and measured tumor onset, size, and multiplicity. They found that tumor size significantly reduced in a dose dependent manner. In addition, in a study by Kiyabu *et al.*<sup>[71]</sup>, 38234 Japanese women aged 45-74 years were followed for a mean duration of 14.1 years and diagnosed with 556 new breast cancers. They found that development of estrogen receptor positive (ER+), progesterone receptor positive (PR+) breast cancers, which are a favorable breast cancer phenotype, were positively associated with intake of  $\omega$ -6 PUFA, whereas it was negatively associated with intake of  $\omega$ -3 PUFA. Overall breast cancer risk, however, was not associated with the intake of combined fish oil PUFA ( $\omega$ -3 PUFA and  $\omega$ -6 PUFA)<sup>[71]</sup>. This provides evidence of an interaction between fish oil PUFA and breast cancer phenotype, however additional studies are required to more clearly elucidate the associations.

Cancer is not only generated by genetic alterations as a result of intrinsic or exogenous mutagens, but also by long-term exposure to acute or chronic inflammation. Persistent inflammation might promote cell transformation through DNA damage, which is one of critical processes of carcinogenesis. Inflammation can also lead to the release of matrix metalloprotease, high mobility group box, which promotes cancer progression by regulating replicative potential, angiogenesis, apoptosis, and self-sufficiency in growth signals<sup>[72]</sup>. Considering that resolvins is a potent anti-inflammatory mediator, we cannot help but speculate that it suppress cancer progression in the context of inflammation-related carcinogenesis. In fact, Kuang *et al.*<sup>[73]</sup> found that resolvins D1 and E1 prevent liver injury and the changes of hepatitis to liver cancer in mice. Moreover, resolvins have been shown to suppress epithelial mesenchymal transition (EMT), which is a key event in metastasis of cancer. Interestingly, Lee *et al.*<sup>[74]</sup> found that resolvins inhibited transforming growth factor (TGF)- $\beta$ 1-induced EMT of A549 human lung cancer cells *in vitro*. TGF- $\beta$ 1, which is known to induce EMT of lung cancer cells, is one of the featured mediators in the resolution of inflammation and key components comprising the tumor microenvironment. Thus, modulation of TGF- $\beta$ 1

by resolvins offers therapeutic potential in treating and/or preventing metastatic spread of cancer<sup>[75]</sup>. Currently, there are only a small number of studies that investigate the correlation between resolvins and cancer in humans, but the spread of tandem mass spectrometry will make it possible to gain more data regarding the suppressive or protective effect of resolvins on cancer progress not only in experimental models, but also in human patients.

## FUTURE DIRECTIONS

Given its unique function with minimal side-effects, resolvins could represent a new class of anti-inflammatory drugs. Currently, non-steroidal anti-inflammatory drugs (NSAIDs), steroids and opioids are commonly used to treat inflammation and pain caused by injury. NSAIDs in particular are used for a wide spectrum of pathologies including short- and long-term pain relief and various inflammatory conditions. However, NSAIDs can cause several serious adverse effects such as gastric ulceration and renal damage, which are frequently observed in patients with arthritis and other rheumatologic conditions requiring chronic NSAID use<sup>[76]</sup>. The potential side effects with steroids are well known with systemic and psychological side effects including abnormal lipogenesis and fat distribution, adrenal insufficiency, osteoporosis, glaucoma, menstrual irregularity, and immune compromise<sup>[77]</sup>. Despite these side effects, steroids remain the first-line therapies for several diseases such as inflammatory bowel disease, rheumatoid arthritis and other autoimmune conditions. We cannot help speculate that treatment with lipid mediators, such as resolvins, may be a breakthrough for these patients.

It is well established that aspirin decreases the development and progression of colon adenomas. Aspirin irreversibly inactivates the cyclooxygenase enzyme, thus decreasing the production of inflammatory precursors PG and thromboxanes. However, the side effects of aspirin have prevented it to be widely used for chemoprevention of colon cancer. Hull *et al*<sup>[78]</sup> are currently conducting a trial investigating whether EPA is as effective as aspirin, or has additive effect. Another ongoing trial randomizes patients with colonoscopy-identified colon adenomas to either EPA intake or placebo for one year with measured levels of  $\omega$ -3 PUFA and RvE1 in plasma, urine, erythrocytes and rectal mucosa. These studies will provide further evidence regarding the efficacy of resolvins in affecting cancer progression.

It is widely accepted that preoperative optimization of immune function improves the postoperative outcome. Due to the minimal side effects, resolvins could be given perioperatively unlike many other drugs due to its absence of impact on wound healing. It is well known that surgical stress and inflammation cause global metabolic suppression. Preoperative

restoration of immune function could potentially reduce postoperative infectious complication, reduce use of resources, and improve patient outcomes. It may also prompt early ambulation and avoid disuse syndrome.

## CONCLUSION

In summary,  $\omega$ -3-PUFA plays important roles in inflammation-related diseases, with resolvins playing a central mechanistic role. Resolvins may be a key player for treatment of inflammation-related diseases. Further investigation will be needed to develop new therapies utilizing the anti-inflammatory lipid mediators for people suffering with those inflammation-related diseases and cancers.

## REFERENCES

- 1 **Bastard JP**, Maachi M, Lagathu C, Kim MJ, Caron M, Vidal H, Capeau J, Feve B. Recent advances in the relationship between obesity, inflammation, and insulin resistance. *Eur Cytokine Netw* 2006; **17**: 4-12 [PMID: 16613757]
- 2 **Pradhan AD**, Manson JE, Rifai N, Buring JE, Ridker PM. C-reactive protein, interleukin 6, and risk of developing type 2 diabetes mellitus. *JAMA* 2001; **286**: 327-334 [PMID: 11466099 DOI: 10.1001/jama.286.3.327]
- 3 **Akiyama H**, Barger S, Barnum S, Bradt B, Bauer J, Cole GM, Cooper NR, Eikelenboom P, Emmerling M, Fiebich BL, Finch CE, Frautschy S, Griffin WS, Hampel H, Hull M, Landreth G, Lue L, Mrak R, Mackenzie IR, McGeer PL, O'Banion MK, Pachter J, Pasinetti G, Plata-Salaman C, Rogers J, Rydel R, Shen Y, Streit W, Strohmeier R, Tooyoma I, Van Muiswinkel FL, Veerhuis R, Walker D, Webster S, Wegrzyniak B, Wenk G, Wyss-Coray T. Inflammation and Alzheimer's disease. *Neurobiol Aging* 2000; **21**: 383-421 [PMID: 10858586]
- 4 **Coussens LM**, Werb Z. Inflammation and cancer. *Nature* 2002; **420**: 860-867 [PMID: 12490959 DOI: 10.1038/nature01322]
- 5 **Balkwill F**, Mantovani A. Inflammation and cancer: back to Virchow? *Lancet* 2001; **357**: 539-545 [PMID: 11229684 DOI: 10.1016/S0140-6736(00)04046-0]
- 6 **Matsuo Y**, Sawai H, Funahashi H, Takahashi H, Sakamoto M, Yamamoto M, Okada Y, Hayakawa T, Manabe T. Enhanced angiogenesis due to inflammatory cytokines from pancreatic cancer cell lines and relation to metastatic potential. *Pancreas* 2004; **28**: 344-352 [PMID: 15084984]
- 7 **Patterson WL**, Georgel PT. Breaking the cycle: the role of omega-3 polyunsaturated fatty acids in inflammation-driven cancers. *Biochem Cell Biol* 2014; **92**: 321-328 [PMID: 25098909 DOI: 10.1139/bcb-2013-0127]
- 8 **Serhan CN**, Brain SD, Buckley CD, Gilroy DW, Haslett C, O'Neill LA, Perretti M, Rossi AG, Wallace JL. Resolution of inflammation: state of the art, definitions and terms. *FASEB J* 2007; **21**: 325-332 [PMID: 17267386 DOI: 10.1096/fj.06-7227rev]
- 9 **Samuelsson B**. Leukotrienes: mediators of immediate hypersensitivity reactions and inflammation. *Science* 1983; **220**: 568-575 [PMID: 6301011]
- 10 **Flower RJ**. Prostaglandins, bioassay and inflammation. *Br J Pharmacol* 2006; **147** Suppl 1: S182-S192 [PMID: 16402103 DOI: 10.1038/sj.bjp.0706506]
- 11 **Nolan E**, O'Meara YM, Godson C. Lipid mediators of inflammation in obesity-related glomerulopathy. *Nephrol Dial Transplant* 2013; **28** Suppl 4: iv22-iv29 [PMID: 24081855 DOI: 10.1093/ndt/gft392]
- 12 **Gabay C**, Kushner I. Acute-phase proteins and other systemic responses to inflammation. *N Engl J Med* 1999; **340**: 448-454 [PMID: 9971870 DOI: 10.1056/nejm199902113400607]
- 13 **Meister D**, Ghosh S. Effect of fish oil enriched enteral diet on

- inflammatory bowel disease tissues in organ culture: differential effects on ulcerative colitis and Crohn's disease. *World J Gastroenterol* 2005; **11**: 7466-7472 [PMID: 16437718]
- 14 **Serhan CN**, Clish CB, Brannon J, Colgan SP, Chiang N, Gronert K. Novel functional sets of lipid-derived mediators with antiinflammatory actions generated from omega-3 fatty acids via cyclooxygenase 2-nonsteroidal antiinflammatory drugs and transcellular processing. *J Exp Med* 2000; **192**: 1197-1204 [PMID: 11034610]
- 15 **Serhan CN**. Pro-resolving lipid mediators are leads for resolution physiology. *Nature* 2014; **510**: 92-101 [PMID: 24899309 DOI: 10.1038/nature13479]
- 16 **Murakami M**. Lipid mediators in life science. *Exp Anim* 2011; **60**: 7-20 [PMID: 21325748]
- 17 **Stables MJ**, Gilroy DW. Old and new generation lipid mediators in acute inflammation and resolution. *Prog Lipid Res* 2011; **50**: 35-51 [PMID: 20655950 DOI: 10.1016/j.plipres.2010.07.005]
- 18 **Shimizu T**. Lipid mediators in health and disease: enzymes and receptors as therapeutic targets for the regulation of immunity and inflammation. *Annu Rev Pharmacol Toxicol* 2009; **49**: 123-150 [PMID: 18834304 DOI: 10.1146/annurev.pharmtox.011008.145616]
- 19 **Nagahashi M**, Matsuda Y, Moro K, Tsuchida J, Soma D, Hirose Y, Kobayashi T, Kosugi SI, Takabe K, Komatsu M, Wakai T. DNA damage response and sphingolipid signaling in liver diseases. *Surg Today* 2015 Oct 29; Epub ahead of print [PMID: 26514817 DOI: 10.1007/s00595-015-1270-8]
- 20 **Nagahashi M**, Ramachandran S, Kim EY, Allegood JC, Rashid OM, Yamada A, Zhao R, Milstien S, Zhou H, Spiegel S, Takabe K. Sphingosine-1-phosphate produced by sphingosine kinase 1 promotes breast cancer progression by stimulating angiogenesis and lymphangiogenesis. *Cancer Res* 2012; **72**: 726-735 [PMID: 22298596 DOI: 10.1158/0008-5472.can-11-2167]
- 21 **Liang J**, Nagahashi M, Kim EY, Harikumar KB, Yamada A, Huang WC, Hait NC, Allegood JC, Price MM, Avni D, Takabe K, Kordula T, Milstien S, Spiegel S. Sphingosine-1-phosphate links persistent STAT3 activation, chronic intestinal inflammation, and development of colitis-associated cancer. *Cancer Cell* 2013; **23**: 107-120 [PMID: 23273921 DOI: 10.1016/j.ccr.2012.11.013]
- 22 **Ramachandran S**, Shida D, Nagahashi M, Fang X, Milstien S, Takabe K, Spiegel S. Lysophosphatidic acid stimulates gastric cancer cell proliferation via ERK1-dependent upregulation of sphingosine kinase 1 transcription. *FEBS Lett* 2010; **584**: 4077-4082 [PMID: 20804754 DOI: 10.1016/j.febslet.2010.08.035]
- 23 **Godson C**, Mitchell S, Harvey K, Petasis NA, Hogg N, Brady HR. Cutting edge: lipoxins rapidly stimulate nonphlogistic phagocytosis of apoptotic neutrophils by monocyte-derived macrophages. *J Immunol* 2000; **164**: 1663-1667 [PMID: 10657608]
- 24 **Schwab JM**, Chiang N, Arita M, Serhan CN. Resolvin E1 and protectin D1 activate inflammation-resolution programmes. *Nature* 2007; **447**: 869-874 [PMID: 17568749 DOI: 10.1038/nature05877]
- 25 **Gronert K**, Maheshwari N, Khan N, Hassan IR, Dunn M, Laniado Schwartzman M. A role for the mouse 12/15-lipoxygenase pathway in promoting epithelial wound healing and host defense. *J Biol Chem* 2005; **280**: 15267-15278 [PMID: 15708862 DOI: 10.1074/jbc.M410638200]
- 26 **Titos E**, Rius B, González-Pérez A, López-Vicario C, Morán-Salvador E, Martínez-Clemente M, Arroyo V, Clària J. Resolvin D1 and its precursor docosahexaenoic acid promote resolution of adipose tissue inflammation by eliciting macrophage polarization toward an M2-like phenotype. *J Immunol* 2011; **187**: 5408-5418 [PMID: 22013115 DOI: 10.4049/jimmunol.1100225]
- 27 **Recchiuti A**, Serhan CN. Pro-Resolving Lipid Mediators (SPMs) and Their Actions in Regulating miRNA in Novel Resolution Circuits in Inflammation. *Front Immunol* 2012; **3**: 298 [PMID: 23093949 DOI: 10.3389/fimmu.2012.00298]
- 28 **Karp CL**, Flick LM, Park KW, Softic S, Greer TM, Keledjian R, Yang R, Uddin J, Guggino WB, Atabani SF, Belkaid Y, Xu Y, Whitsett JA, Accurso FJ, Wills-Karp M, Petasis NA. Defective lipoxin-mediated anti-inflammatory activity in the cystic fibrosis airway. *Nat Immunol* 2004; **5**: 388-392 [PMID: 15034576 DOI: 10.1038/ni1056]
- 29 **Chan MM**, Moore AR. Resolution of inflammation in murine autoimmune arthritis is disrupted by cyclooxygenase-2 inhibition and restored by prostaglandin E2-mediated lipoxin A4 production. *J Immunol* 2010; **184**: 6418-6426 [PMID: 20435922 DOI: 10.4049/jimmunol.0903816]
- 30 **Campanholle G**, Ligresti G, Gharib SA, Duffield JS. Cellular mechanisms of tissue fibrosis. 3. Novel mechanisms of kidney fibrosis. *Am J Physiol Cell Physiol* 2013; **304**: C591-C603 [PMID: 23325411 DOI: 10.1152/ajpcell.00414.2012]
- 31 **Dandona P**, Aljada A, Chaudhuri A, Mohanty P, Garg R. Metabolic syndrome: a comprehensive perspective based on interactions between obesity, diabetes, and inflammation. *Circulation* 2005; **111**: 1448-1454 [PMID: 15781756 DOI: 10.1161/01.cir.0000158-483.13093.9d]
- 32 **Xu MX**, Tan BC, Zhou W, Wei T, Lai WH, Tan JW, Dong JH. Resolvin D1, an endogenous lipid mediator for inactivation of inflammation-related signaling pathways in microglial cells, prevents lipopolysaccharide-induced inflammatory responses. *CNS Neurosci Ther* 2013; **19**: 235-243 [PMID: 23521911 DOI: 10.1111/cns.12069]
- 33 **Knab LM**, Grippo PJ, Bentrem DJ. Involvement of eicosanoids in the pathogenesis of pancreatic cancer: the roles of cyclooxygenase-2 and 5-lipoxygenase. *World J Gastroenterol* 2014; **20**: 10729-10739 [PMID: 25152576 DOI: 10.3748/wjg.v20.i31.10729]
- 34 **Schwenger KJ**, Allard JP. Clinical approaches to non-alcoholic fatty liver disease. *World J Gastroenterol* 2014; **20**: 1712-1723 [PMID: 24587650 DOI: 10.3748/wjg.v20.i7.1712]
- 35 **Cabré E**, Domènech E. Impact of environmental and dietary factors on the course of inflammatory bowel disease. *World J Gastroenterol* 2012; **18**: 3814-3822 [PMID: 22876032 DOI: 10.3748/wjg.v18.i29.3814]
- 36 **Arita M**. Mediator lipidomics in acute inflammation and resolution. *J Biochem* 2012; **152**: 313-319 [PMID: 22923733 DOI: 10.1093/jb/mvs092]
- 37 **Dyerberg J**, Bang HO, Hjorne N. Fatty acid composition of the plasma lipids in Greenland Eskimos. *Am J Clin Nutr* 1975; **28**: 958-966 [PMID: 1163480]
- 38 **Serhan CN**, Dalli J, Colas RA, Winkler JW, Chiang N. Protectins and maresins: New pro-resolving families of mediators in acute inflammation and resolution bioactive metabolome. *Biochim Biophys Acta* 2015; **1851**: 397-413 [PMID: 25139562 DOI: 10.1016/j.bbali.2014.08.006]
- 39 **Oh SF**, Pillai PS, Recchiuti A, Yang R, Serhan CN. Pro-resolving actions and stereoselective biosynthesis of 18S E-series resolvins in human leukocytes and murine inflammation. *J Clin Invest* 2011; **121**: 569-581 [PMID: 21206090 DOI: 10.1172/jci42545]
- 40 **Arita M**, Bianchini F, Aliberti J, Sher A, Chiang N, Hong S, Yang R, Petasis NA, Serhan CN. Stereochemical assignment, antiinflammatory properties, and receptor for the omega-3 lipid mediator resolvin E1. *J Exp Med* 2005; **201**: 713-722 [PMID: 15753205 DOI: 10.1084/jem.20042031]
- 41 **Tjonahen E**, Oh SF, Siegelman J, Elangovan S, Percarpio KB, Hong S, Arita M, Serhan CN. Resolvin E2: identification and anti-inflammatory actions: pivotal role of human 5-lipoxygenase in resolvin E series biosynthesis. *Chem Biol* 2006; **13**: 1193-1202 [PMID: 17114001 DOI: 10.1016/j.chembiol.2006.09.011]
- 42 **Isobe Y**, Arita M, Matsueda S, Iwamoto R, Fujihara T, Nakanishi H, Taguchi R, Masuda K, Sasaki K, Urabe D, Inoue M, Arai H. Identification and structure determination of novel anti-inflammatory mediator resolvin E3, 17,18-dihydroxyeicosapentaenoic acid. *J Biol Chem* 2012; **287**: 10525-10534 [PMID: 22275352 DOI: 10.1074/jbc.M112.340612]
- 43 **Wang J**, Yu JC, Kang WM, Ma ZQ. Superiority of a fish oil-enriched emulsion to medium-chain triacylglycerols/long-chain triacylglycerols in gastrointestinal surgery patients: a randomized clinical trial. *Nutrition* 2012; **28**: 623-629 [PMID: 22113064 DOI: 10.1016/j.nut.2011.08.004]
- 44 **Spite M**, Norling LV, Summers L, Yang R, Cooper D, Petasis NA, Flower RJ, Perretti M, Serhan CN. Resolvin D2 is a potent regulator



- of leukocytes and controls microbial sepsis. *Nature* 2009; **461**: 1287-1291 [PMID: 19865173 DOI: 10.1038/nature08541]
- 45 **Kang JX**. Fat-1 transgenic mice: a new model for omega-3 research. *Prostaglandins Leukot Essent Fatty Acids* 2007; **77**: 263-267 [PMID: 18042365 DOI: 10.1016/j.plefa.2007.10.010]
- 46 **Tomio K**, Kawana K, Taguchi A, Isobe Y, Iwamoto R, Yamashita A, Kojima S, Mori M, Nagamatsu T, Arimoto T, Oda K, Osuga Y, Taketani Y, Kang JX, Arai H, Arita M, Kozuma S, Fujii T. Omega-3 polyunsaturated Fatty acids suppress the cystic lesion formation of peritoneal endometriosis in transgenic mouse models. *PLoS One* 2013; **8**: e73085 [PMID: 24039864 DOI: 10.1371/journal.pone.0073085]
- 47 **Zivkovic AM**, Yang J, Georgi K, Hegedus C, Nording ML, O'Sullivan A, German JB, Hogg RJ, Weiss RH, Bay C, Hammock BD. Serum oxylipin profiles in IgA nephropathy patients reflect kidney functional alterations. *Metabolomics* 2012; **8**: 1102-1113 [PMID: 23833568 DOI: 10.1007/s11306-012-0417-5]
- 48 **Zhang X**, Qu X, Sun YB, Caruana G, Bertram JF, Nikolic-Paterson DJ, Li J. Resolvin D1 protects podocytes in adriamycin-induced nephropathy through modulation of 14-3-3 $\beta$  acetylation. *PLoS One* 2013; **8**: e67471 [PMID: 23840712 DOI: 10.1371/journal.pone.0067471]
- 49 **Yang J**, Eiserich JP, Cross CE, Morrissey BM, Hammock BD. Metabolomic profiling of regulatory lipid mediators in sputum from adult cystic fibrosis patients. *Free Radic Biol Med* 2012; **53**: 160-171 [PMID: 22580336 DOI: 10.1016/j.freeradbiomed.2012.05.001]
- 50 **Wang L**, Yuan R, Yao C, Wu Q, Christelle M, Xie W, Zhang X, Sun W, Wang H, Yao S. Effects of resolvin D1 on inflammatory responses and oxidative stress of lipopolysaccharide-induced acute lung injury in mice. *Chin Med J (Engl)* 2014; **127**: 803-809 [PMID: 24571866]
- 51 **Herrera BS**, Hasturk H, Kantarci A, Freire MO, Nguyen O, Kansal S, Van Dyke TE. Impact of resolvin E1 on murine neutrophil phagocytosis in type 2 diabetes. *Infect Immun* 2015; **83**: 792-801 [PMID: 25486994 DOI: 10.1128/iai.02444-14]
- 52 **Miyahara T**, Runge S, Chatterjee A, Chen M, Mottola G, Fitzgerald JM, Serhan CN, Conte MS. D-series resolvins attenuates vascular smooth muscle cell activation and neointimal hyperplasia following vascular injury. *FASEB J* 2013; **27**: 2220-2232 [PMID: 23407709 DOI: 10.1096/fj.12-225615]
- 53 **Hashimoto M**, Kato S, Tamai T, Tanabe Y, Mitarai M, Matsumoto I, Ohno M. Beneficial effects of daily dietary omega-3 polyunsaturated fatty acid supplementation on age-related cognitive decline in elderly Japanese with very mild dementia: a 2-year randomized, double-blind, placebo-controlled trial. *J Aging Res Clin Practice* 2012; **1**: 193-201
- 54 **Quinn JF**, Raman R, Thomas RG, Yurko-Mauro K, Nelson EB, Van Dyck C, Galvin JE, Emond J, Jack CR, Weiner M, Shinto L, Aisen PS. Docosahexaenoic acid supplementation and cognitive decline in Alzheimer disease: a randomized trial. *JAMA* 2010; **304**: 1903-1911 [PMID: 21045096 DOI: 10.1001/jama.2010.1510]
- 55 **Nathan C**, Ding A. Nonresolving inflammation. *Cell* 2010; **140**: 871-882 [PMID: 20303877 DOI: 10.1016/j.cell.2010.02.029]
- 56 **Bahnassy AA**, Zekri AR, El-Bastawisy A, Fawzy A, Shetta M, Hussein N, Omran D, Ahmed AA, El-Labbady SS. Circulating tumor and cancer stem cells in hepatitis C virus-associated liver disease. *World J Gastroenterol* 2014; **20**: 18240-18248 [PMID: 25561791 DOI: 10.3748/wjg.v20.i48.18240]
- 57 **Bruix J**, Sherman M. Management of hepatocellular carcinoma. *Hepatology* 2005; **42**: 1208-1236 [PMID: 16250051 DOI: 10.1002/hep.20933]
- 58 **Walboomers JM**, Jacobs MV, Manos MM, Bosch FX, Kummer JA, Shah KV, Snijders PJ, Peto J, Meijer CJ, Muñoz N. Human papillomavirus is a necessary cause of invasive cervical cancer worldwide. *J Pathol* 1999; **189**: 12-19 [PMID: 10451482 DOI: 10.1002/(sici)1096-9896(199909)189]
- 59 **Groves IJ**, Coleman N. Pathogenesis of human papillomavirus-associated mucosal disease. *J Pathol* 2015; **235**: 527-538 [PMID: 25604863 DOI: 10.1002/path.4496]
- 60 **Parsonnet J**, Friedman GD, Vandersteen DP, Chang Y, Vogelman JH, Orentreich N, Sibley RK. Helicobacter pylori infection and the risk of gastric carcinoma. *N Engl J Med* 1991; **325**: 1127-1131 [PMID: 1891020 DOI: 10.1056/nejm199110173251603]
- 61 **Hwang JJ**, Lee DH, Lee AR, Yoon H, Shin CM, Park YS, Kim N. Characteristics of gastric cancer in peptic ulcer patients with Helicobacter pylori infection. *World J Gastroenterol* 2015; **21**: 4954-4960 [PMID: 25945009 DOI: 10.3748/wjg.v21.i16.4954]
- 62 **Silverman DT**, Hartge P, Morrison AS, Devesa SS. Epidemiology of bladder cancer. *Hematol Oncol Clin North Am* 1992; **6**: 1-30 [PMID: 1556044]
- 63 **Botelho MC**, Figueiredo J, Alves H. Bladder cancer and urinary Schistosomiasis in Angola. *J Nephrol Res* 2015; **1**: 22-24 [PMID: 26167543 DOI: 10.17554/j.issn.2410-0579.2015.01.4]
- 64 **Watanabe T**, Soga K, Hirono H, Hasegawa S, Shibasaki K, Kawai H, Aoyagi Y. Features of hepatocellular carcinoma in cases with autoimmune hepatitis and primary biliary cirrhosis. *World J Gastroenterol* 2009; **15**: 231-239 [PMID: 19132775]
- 65 **Seery JP**. Stem cells of the oesophageal epithelium. *J Cell Sci* 2002; **115**: 1783-1789 [PMID: 11956310]
- 66 **Chai J**, Jamal MM. Esophageal malignancy: a growing concern. *World J Gastroenterol* 2012; **18**: 6521-6526 [PMID: 23236223 DOI: 10.3748/wjg.v18.i45.6521]
- 67 **Nushijima Y**, Nakano K, Sugimoto K, Nakaguchi K, Kan K, Maruyama H, Doi S, Okamura S, Murata K. A case of primary carcinoma associated with anal fistula. *Gan To Kagaku Ryoho* 2014; **41**: 1872-1874 [PMID: 25731359]
- 68 **Freeman HJ**. Colorectal cancer risk in Crohn's disease. *World J Gastroenterol* 2008; **14**: 1810-1811 [PMID: 18350616]
- 69 **Mocellin MC**, Camargo CQ, Nunes EA, Fiates GM, Trindade EB. A systematic review and meta-analysis of the n-3 polyunsaturated fatty acids effects on inflammatory markers in colorectal cancer. *Clin Nutr* 2016; **35**: 359-369 [PMID: 25982417 DOI: 10.1016/j.clnu.2015.04.013]
- 70 **Leslie MA**, Abdelmagid SA, Perez K, Muller WJ, Ma DW. Mammary tumour development is dose-dependently inhibited by n-3 polyunsaturated fatty acids in the MMTV-neu(ndl)-YD5 transgenic mouse model. *Lipids Health Dis* 2014; **13**: 96 [PMID: 24916956 DOI: 10.1186/1476-511x-13-96]
- 71 **Kiyabu GY**, Inoue M, Saito E, Abe SK, Sawada N, Ishihara J, Iwasaki M, Yamaji T, Shimazu T, Sasazuki S, Shibuya K, Tsugane S. Fish, n-3 polyunsaturated fatty acids and n-6 polyunsaturated fatty acids intake and breast cancer risk: The Japan Public Health Center-based prospective study. *Int J Cancer* 2015; **137**: 2915-2926 [PMID: 26147326 DOI: 10.1002/ijc.29672]
- 72 **Tang D**, Kang R, Livesey KM, Cheh CW, Farkas A, Loughran P, Hoppe G, Bianchi ME, Tracey KJ, Zeh HJ, Lotze MT. Endogenous HMGB1 regulates autophagy. *J Cell Biol* 2010; **190**: 881-892 [PMID: 20819940 DOI: 10.1083/jcb.200911078]
- 73 **Kuang H**, Hua X, Zhou J, Yang R. Resolvin D1 and E1 alleviate the progress of hepatitis toward liver cancer in long-term concanavalin A-induced mice through inhibition of NF- $\kappa$ B activity. *Oncol Rep* 2016; **35**: 307-317 [PMID: 26531230 DOI: 10.3892/or.2015.4389]
- 74 **Lee HJ**, Park MK, Lee EJ, Lee CH. Resolvin D1 inhibits TGF- $\beta$ 1-induced epithelial mesenchymal transition of A549 lung cancer cells via lipoxin A4 receptor/formyl peptide receptor 2 and GPR32. *Int J Biochem Cell Biol* 2013; **45**: 2801-2807 [PMID: 24120851 DOI: 10.1016/j.biocel.2013.09.018]
- 75 **Gemmill RM**, Roche J, Potiron VA, Nasarre P, Mitas M, Coldren CD, Helfrich BA, Garrett-Mayer E, Bunn PA, Drabkin HA. ZEB1-responsive genes in non-small cell lung cancer. *Cancer Lett* 2011; **300**: 66-78 [PMID: 20980099 DOI: 10.1016/j.canlet.2010.09.007]
- 76 **Leone S**, Ottani A, Bertolini A. Dual acting anti-inflammatory drugs. *Curr Top Med Chem* 2007; **7**: 265-275 [PMID: 17305569]
- 77 **Mori H**, Fujihara S, Nishiyama N, Kobara H, Oryu M, Kato K, Rafiq K, Masaki T. Cytomegalovirus-associated gastric ulcer: a side effect of steroid injections for pyloric stenosis. *World J Gastroenterol* 2013; **19**: 1143-1146 [PMID: 23467493 DOI: 10.3748/wjg.v19.i7.1143]
- 78 **Hull MA**, Sandell AC, Montgomery AA, Logan RF, Clifford GM, Rees CJ, Loadman PM, Whitham D. A randomized controlled trial of eicosapentaenoic acid and/or aspirin for colorectal adenoma

prevention during colonoscopic surveillance in the NHS Bowel Cancer Screening Programme (The seAFood Polyp Prevention

Trial): study protocol for a randomized controlled trial. *Trials* 2013; **14**: 237 [PMID: 23895505 DOI: 10.1186/1745-6215-14-237]

**P- Reviewer:** Hsu CP, Hammes M, Lin ZY **S- Editor:** Ji FF  
**L- Editor:** A **E- Editor:** Wu HL





Published by **Baishideng Publishing Group Inc**

8226 Regency Drive, Pleasanton, CA 94588, USA

Telephone: +1-925-223-8242

Fax: +1-925-223-8243

E-mail: [bpgoffice@wjgnet.com](mailto:bpgoffice@wjgnet.com)

Help Desk: <http://www.wjgnet.com/esps/helpdesk.aspx>

<http://www.wjgnet.com>

