



Isolation and identification of *Listeria monocytogenes*

K G Kerr, R W Lacey

Introduction

The incidence of human listeriosis continues to increase. The causative organism, *Listeria monocytogenes*, is responsible for a variety of clinical syndromes in several high risk groups. Infection in pregnant women commonly causes a benign self limiting flu-like illness in the mother, but may ultimately result in abortion, stillbirth, or the birth of a live child with signs of neonatal listeriosis at birth or within the first few days of life. Somewhat analogous to β haemolytic group B streptococcus, a late onset form of neonatal listeriosis has also been identified. In non-pregnant adults and in juveniles many studies indicate that disease of the central nervous system, usually meningitis, is the commonest form of the disease, accounting for about two thirds of cases. Primary bacteraemia accounts for roughly 25% of cases and the remainder consists of endocarditis and an ever increasing variety of focal infections. Although commonly considered a disease of the immunosuppressed, up to 30% of adults have no apparent predisposing condition.¹

Microbiological and epidemiological evidence from both sporadic and epidemic cases strongly implicates contaminated foodstuffs, such as soft cheese, as the source of the organism. In the investigation of a case of human listeriosis suspect foodstuffs should be examined for the presence of *L. monocytogenes*. This is often impracticable as the incubation period for listeriosis may be as long as five weeks and incriminated foodstuffs are likely to have been eaten or discarded in the interim.

In adult listeriosis blood and cerebrospinal fluid should be cultured. Samples of faeces may also be obtained. Focal infections are reported with increasing frequency and pus, cardiac valve vegetations, corneal scrapings, etc, should be submitted for culture where appropriate. In suspected maternofetal listeriosis blood cultures may be taken from pregnant women with a "flu like" illness. Neonates with sepsis should have blood and cerebrospinal fluid cultures taken. Genital tract secretions and rectal swabs or faeces should be obtained from their mothers. In

cases of abortion or stillbirth placental and fetal necropsy samples should be submitted for culture as the typical features of listeriosis may be absent or inapparent on both gross inspection and subsequent histological examination. Where possible, food histories are obtained and high risk foodstuffs (such as paté and soft cheese), are cultured and quantitative counts performed.

Transport of specimens

Samples should reach the laboratory as soon as possible. If there is a delay the samples can be refrigerated. Food samples should be conveyed to the laboratory in an ice box or "cool bag", if quantitative counts are to be performed.

Non-cultural examination of specimens

Gram staining of cerebrospinal fluid and specimens from normally sterile sites may suggest a diagnosis of listeriosis. *Listeria* usually appear as short, Gram positive rods which may be seen both intra- and extracellularly. Sometimes it may be difficult to distinguish *Listeria* from coryneforms and streptococci in Gram smears. It should be noted that results of cytological and biochemical analysis of cerebrospinal fluid in listeria meningitis may not suggest a pyogenic meningitic process—for example, hypoglycorrhachia is not a consistent finding,² Gram stains of samples likely to be contaminated with other organisms may yield a predominance of short Gram positive rods.

Other methods for the direct detection of *Listeria* spp include enzyme linked immunosorbent assays, fluorescence antibody techniques, and the polymerase chain reaction: these have yet to be fully evaluated and cannot at present be recommended for use in the diagnosis of listeriosis.

Isolation from normally sterile sites

L. monocytogenes is easily isolated from specimens taken from normally sterile sites and

This Broadsheet has been prepared by the authors at the invitation of the Association of Clinical Pathologists who reserve the copyright. Further copies of this Broadsheet may be obtained from the Publishing Manager, Journal of Clinical Pathology, BMA House, Tavistock Square, WC1H 9JR

ACP copyright

Department of
Microbiology, University of Leeds, Leeds
LS2 9JT

K G Kerr
R W Lacey

Correspondence to:
Dr K G Kerr

Accepted for publication
18 December 1990

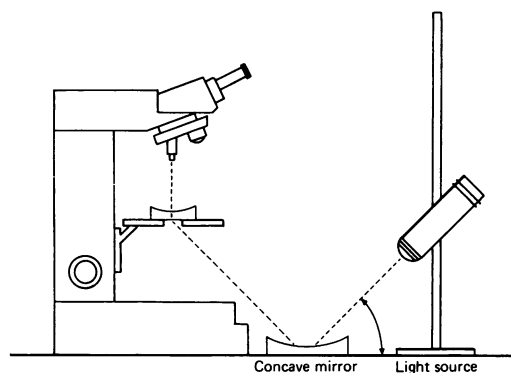

Figure 1 The Henry technique.

will grow well on non-selective media such as blood agar after 18 hours' incubation. *Listeria* spp grow over a wide temperature range with an optimum in the range 30–37°C. Although the organisms grow best under microaerophilic conditions, aerobic or anaerobic incubation is perfectly acceptable for the clinical laboratory. Growth under anaerobic conditions enhances the zones of haemolysis around haemolytic *Listeria* spp. Alternatively, stabbing the agar with the loop during plating out of a specimen will enhance haemolysis of cultures incubated aerobically.

Specimens of cerebrospinal fluid and from normally sterile sites, where numbers of organisms may be low should be enriched in brain heart infusion broth before subculture.

Culture of clinical specimens likely to be contaminated with other organisms and from food or environmental samples is complicated by the fact that there are a plethora of selective enrichment techniques currently available. Despite attempts at standardisation there is no universally accepted method for isolating *Listeria monocytogenes* from contaminated specimens and it is recommended that each laboratory familiarise itself with one of the methods described below.

Traditionally, selective enrichment of such material has involved cold enrichment at 4°C. Growth at low temperature, however, may be slow and thus may considerably delay the isolation and identification of the organism. More recently, selective enrichment broths have been introduced (see below). These media contain acriflavine, and it should be remembered that this substance is actually inhibitory for *Listeria monocytogenes*, especially towards organisms which may have been sublethally damaged by heat, antimicrobial drugs, etc. It should also be noted that some fosfomycin containing agars such as Oxford medium may inhibit the growth of *L. ivanovii*.

Isolation from specimens likely to be contaminated with other organisms

Make a 1 in 10 dilution of the specimen in FDA *Listeria* Enrichment Broth³: LEB (Lab M, Bury, Lancs BL9 6AU) and incubate in air at 30°C and subculture on to either Oxford agar (Oxoid, Basingstoke, Hants RG24 0PW; Lab M, Bury, Lancs; Mast Laboratories, Bootle, Merseyside L20 1EA), PALCAM (Oxoid), or

LPM agar (Appendix) after 24 and 48 hours of incubation. Incubation may be extended to seven days, but it is uncertain as to whether this increases isolation rates. Treatment of broth samples with 0.5% KOH (1:10 w/v) before plating on to solid media has also been recommended but is probably unnecessary in most instances. For the examination of foodstuffs, 25 g of food is homogenised in 225 ml of LEB in a stomacher and incubated as above. Quantitative counts on selective agar should be performed after homogenisation of the sample. Colonies of *Listeria* spp and other aesculin hydrolysing organisms on both PALCAM and Oxford agar are surrounded by a black halo. PALCAM agar also contains mannitol and an indicator—phenol red. *L. monocytogenes* and most other *Listeria* spp are mannitol non-fermenters; thus black colonies which do not turn the surrounding agar yellow merit further investigation. It should be noted that the complex responsible for the black discoloration of the medium diffuses widely on prolonged incubation at both room temperature and 37°C and plates, thus making it difficult to identify individual aesculin hydrolysing colonies. On LPM, as with other clear isolation media, *Listeria* spp may be identified by a characteristic blue green appearance of the colonies when viewed by obliquely transmitted light—the Henry technique, as modified by Gray (fig 1). This technique is often decried as unreliable and difficult to master, but with a little time and effort it should not be beyond the capabilities of most laboratory workers. Some light sources and mirrors may not be suitable for this technique.² Gray's original paper contains several colour plates illustrating the typical appearance of *L. monocytogenes* when using oblique transillumination, and is recommended for those who wish to use this technique.⁴

Identification of *Listeria* spp

Colonies which are aesculin hydrolysing on Oxford agar, aesculin hydrolysing and mannitol non-fermenting on PALCAM, and blue green on LPM on using the Henry technique are subcultured to blood agar for purity and observation of β haemolysis. With foodstuffs more than one *Listeria* species and more than one serotype of *L. monocytogenes* may be present and several colonies should be picked. It should be noted that the zone of haemolysis surrounding colonies of *L. monocytogenes* and *L. seeligeri* is usually narrow (1–2 mm), and in some instances it may be necessary to remove the colony from the agar for this to be observed. *L. ivanovii* produces a much wider zone of haemolysis on blood agar. Several discrete zones of haemolysis may be observed with this organism. Most cases of human listeriosis are caused by *L. monocytogenes*, but anecdotal reports have implicated the haemolytic species *L. seeligeri* and *L. ivanovii* as causative agents of the disease. Non-haemolytic *Listeria* spp are non-pathogenic and of little interest to the clinical laboratory. We therefore

Identification of (haemolytic) *Listeria* spp*

Organism	Character of haemolysis	Glucose	Salicin	Mannitol	Acid from:		α methyl mannoside	CAMP test	
					xylose	rhamnose		<i>S aureus</i>	<i>R equi</i>
<i>L monocytogenes</i>	Narrow zone†	+	+	-	-	+	+	+	-
<i>L seeligeri</i>	Narrow zone	+	+	-	+	-	-‡	++	-
<i>L ivanovii</i>	Wide zone(s)	+	+	-	+	-	-	-	+

* All strains are catalase, VP, aesculin positive, urease negative and motile at 20°C but not at 37°C (see text).

† It is essential to identify haemolysis as the non-pathogenic, non-haemolytic *L innocua* is biochemically indistinguishable from *L monocytogenes*.

‡ Occasional ($\leq 10\%$) strains may be positive.

†† Positive reactions are weak and may be difficult to identify.

recommended that only haemolytic isolates are examined further. It is essential to identify haemolysis, as the non-pathogenic, non-haemolytic *L innocua* is biochemically indistinguishable from *L monocytogenes*.

Colonies of *Listeria* spp are 0.3–1.5 mm in diameter, are non-pigmented, and reputed to have a sour, buttery smell. Morphology of *Listeria* spp on Gram staining is variable, but in young cultures the organisms appear as short ($0.5 \times 1.2 \mu\text{m}$) diphtheroid-like Gram positive rods, although larger rods or coccal forms may be seen. Coccal forms are most likely to be seen on examination of broth cultures or from clinical material. Smears from older cultures, especially broth cultures, may appear Gram negative.

If gram staining is suggestive of *Listeria*, perform catalase and oxidase tests. Catalase positive, oxidase negative colonies are assessed for motility. *Listeria* spp exhibit characteristic "tumbling" motility when examined using a hanging drop technique. It must be emphasised that flagella are not produced at temperatures above 30°C and thus the organisms are non-motile. To assess motility inoculate two brain heart infusion broths and incubate one at 37°C and the other at room temperature. A known *L monocytogenes* isolate must be included as a positive control. Examine both preparations after six and again at 24 hours' incubation. When incubated at room temperature nearly all cells in the culture are motile, whereas at 37°C cells are poorly or non-motile. If large numbers of colonies are to be examined microtitre trays with wells containing broth may be examined with an inverted microscope. Strains which exhibit tumbling motility at 30°C and not at 37°C should be regarded as presumptive *Listeria* spp and should be submitted to further examination. Tests to confirm identification of an isolate as a *Listeria* sp. are as follows: acetylmethylcarbinol production (Voges Proskauer test; Bacto MR-VP medium, Difco, East Molesey, Surrey KT8 0SE); fermentation of glucose and salicin (see below); and aesculin hydrolysis (if colonies have been isolated on LPM or other non-aesculin containing media). Bile aesculin medium should not be used as bile salts inhibit the growth of *Listeria* spp. *Listeria* spp are urease negative.

Identification of haemolytic *Listeria* spp

Identification to species level of these strains depends, at present, on carbohydrate fermenta-

tion tests and CAMP test reactivity using both *Staphylococcus aureus* and *Rhodococcus equi*. Carbohydrates tested are L rhamnose, D xylose, and α methyl D mannoside (in addition to glucose and salicin for genus level identification). They should be filter sterilised and added to peptone water broths containing a phenol red indicator and the pH adjusted to 7.6.⁵ Final concentrations should be 1%; with the exception of α methyl D mannoside (0.5%). Broths are incubated in air at 37°C for up to seven days. Expected results are shown in the table. Several commercially available kits are available for the determination of carbohydrate fermentation tests. The following are recommended.

API50CH (API Basingstoke, Hants RG22 6HY). This system consists of 49 substrates including those which are relevant for genus level identification of *Listeria*, such as glucose, aesculin, and salicin.⁶

MAST ID (Mast Laboratories, Bootle, Merseyside). This uses an agar incorporation technique. When used with a multipoint inoculation system, this method permits the screening of large numbers of strains and is, therefore, particularly useful in the examination of potentially contaminated foodstuffs. It also includes tests useful for identification to genus level, such as aesculin, glucose, salicin, Voges-Proskauer and urease.⁶

ROSCO system (Lab M, Bury, UK). Substrates for both species and genus carbohydrate fermentation, in addition to Voges-Proskauer urease and aesculin hydrolysis tests, are available. This system depends on detection of preformed enzymes, thus giving results after four hours' incubation if heavy inocula are used.

CAMP Test Originally referring to synergistic haemolysis between *Streptococcus agalactiae* and β haemolysin producing strains of *S aureus*, this test has been modified for use in the identification of β haemolytic *Listeria* spp. *L ivanovii* gives a positive reaction with *Rhodococcus (Corynebacterium) equi*. *L monocytogenes* and *L seeligeri* are positive with *S aureus*, although the latter is often only very weakly positive. In this test a thin (3 mm) layer of sheep blood agar (5% v/v in nutrient or typtose agar) is poured on a nutrient agar base. After drying, either *S aureus* and *R equi* are streaked across the plate and test strains are

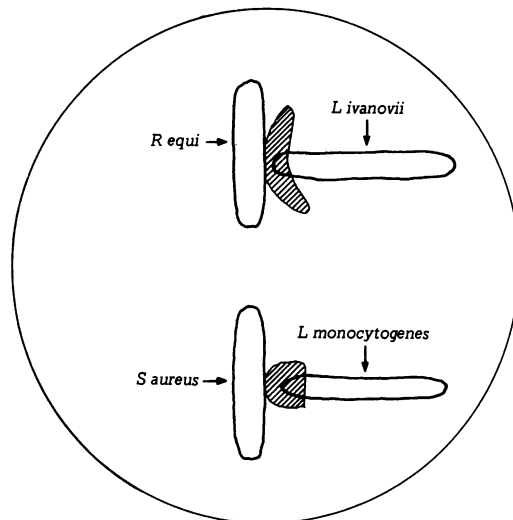

Figure 2 CAMP reaction for *L. ivanovii* and *L. monocytogenes*.

streaked at 90° to the *S. aureus* or *R. equi*. Plates are then incubated at 37°C in air overnight. With *R. equi* and *L. ivanovii* an easily identifiable arrow head zone of haemolysis, typical of the reaction between *S. agalactiae* and *S. aureus* in the conventional CAMP test, is seen. The reaction between *L. seeligeri* and *L. monocytogenes*, however, is less obvious and a blunter, less extensive, zone of haemolysis is noted. Several points must be emphasised with regard to the CAMP test (fig 2). Firstly, only sheep erythrocytes should be used. As some lots may contain inhibitors, cells should be washed twice in phosphate buffered saline before use. Secondly, when inoculating the sheep blood agar plates, test strains should be streaked so that they are no closer than 1 mm to the producer organism. The test is not valid if the inocula touch or intersect. Thirdly, known controls of *L. ivanovii* and *L. monocytogenes* should be included on each plate. Finally, not all strains of *S. aureus* are appropriate for use in the CAMP test, and the use of *S. aureus* NCTC 1803 (and NCTC *R. equi* 1621) have been recommended.⁷

Carbohydrate fermentation, other biochemical tests and CAMP reactions are summarised in the table.

Serology

Isolates identified as *L. monocytogenes* may be further characterised by serotyping. Commercially produced antisera which agglutinate serotypes 1 and 4 — the causative agents of most human cases of listeriosis — are available (Difco, East Molesey, Surrey). Both slide and tube agglutination techniques can be performed (see manufacturer's instructions). Agglutination tests should not be performed on isolates which have not been completely characterised because of serological cross-reactions with many other Gram positive organisms, including haemolytic streptococci.

Appendix

LPM agar⁸

Phenylethanol agar (Difco)	35.5 g/l
Glycine anhydride	10 g/l
Lithium chloride	5 g/l
Moxalactam (Sigma, Poole, Dorset BH17 7TG)	20 mg/l

- Gellin BG, Broome CU. Listeriosis. *JAMA* 1989;261:1313–20.
- Larber B. Diagnosis and management of listeriosis. *Arch Intern Med* 1985;6:68–77.
- McClain D, Lee WH. Development of the USDA-FSIS method of isolation of *Listeria monocytogenes* from raw meat and poultry. *J Assoc Off Anal Chem* 1988;71:660–4.
- Gray ML. A rapid method for the detection of colonies of *Listeria monocytogenes*. *Zentralbl Bakteriol Parasitenkd Infektranskr Hyg I Orig* 1957;169:373–7.
- Rocourt J, Schrettenbrunner A, Seeliger HPR. Differentiation biochimique des groupes génomiques de *Listeria monocytogenes* (sensulato). *Ann Microbiol (Inst Pasteur)* 1983;134A:65–71.
- Kerr KG, Rotowa NA, Hawkey PM, Lacey RW. Evaluation of the Mast ID and API 50CH systems for identification of *Listeria* spp. *Appl Environ Microbiol* 1990;56:652–60.
- McGlauchlin J. The identification of *Listeria* species. *DMRQC Newsletter* 1988;3:1–3.
- Lee WH, McClain D. Improved *Listeria monocytogenes* selective agar. *Appl Environ Microbiol* 1986;52:1215–17.