

Short reports

New sternal puncture needle

A Islam

Abstract

The needles most commonly used for obtaining bone marrow aspirates from the sternum are the Salah and Klima needles. They were designed in the 1930s, and except for the introduction of different kinds of stops and guards there has been no change in their basic structure and design. These instruments are small, do not fit properly in the operator's hand, and the lack of a T-bar handle often makes them difficult to manoeuvre; their introduction into the sternum by twisting or rotary movement of the hand can be cumbersome. To overcome all of these disadvantages an instrument was designed which is larger, provides better grip, and offers improved manoeuvrability. The stilette of this aspiration needle has a domed handle which rests snugly in the operator's hand and affords operator comfort, while the specially shaped large T-bar handle at the proximal end of the needle provides adequate and firm grip and also ensures precise control during the sternal puncture procedure.

Sternal puncture is extensively used in the investigation and diagnosis of various blood dyscrasias and has been found to be a valuable procedure.¹⁻³ Since its introduction in the early 1930s, however, there has been very little change in the construction and basic design of the conventional sternal puncture needles. These instruments are small, do not fit properly in the operator's hand, and are often difficult to manoeuvre during the sternal puncture procedure. We therefore designed a larger and more user friendly needle to surmount the known disadvantages of conventional needles.

Methods

The instrument consists of three parts (fig 1). The needle has an overall length of 45 mm, a uniform external diameter of 1.6 mm, and a constant internal diameter of 1.25 mm, except for the 2-3 mm distal portion where it is bevelled to produce a tip (cutting edge) very similar to hypodermic needles. The proximal end of the needle has been fitted with a large metal bar specially shaped for firm grip and a standard male luer-lock to receive the nozzle of a syringe and to fit the female luer-lock of the stilette and dome handle. The male luer-

lock of the needle also has a sloped stop for easy positioning and for resting the metal stud fixed on the female luer-lock of the stilette. This arrangement facilitates the positioning of the cutting edge of the stilette and needle in the same plane the unlocking and withdrawal of the stilette (by gentle anti-clockwise rotary motion) during the sternal puncture procedure.

The stilette is a solid shaft of 1.1 mm in diameter except for the distal portion where it ends in a 2-3 mm bevelled tip to fit the bevelled tip of the needle to facilitate easy penetration of the soft tissue and bony cortex. The proximal end of the stilette has been fitted with a female luer-lock mounted on the inner side of the dome handle to receive the male luer-lock of the needle. The proximal end of the stilette is capped with a hemispherical smooth, dome-shaped solid nylon handle, 30 mm in diameter and 15 mm deep with a 7-10 mm lightly milled edge. It rests snugly in the operator's hand and the two together (the dome and the bar handle) provide a uniquely designed instrument to carry out the sternal puncture procedure with ease, comfort (fig 2), and confidence.

The guard is adjustable and can be fixed at any point over the needle by tightening the screw. The adjustable guard is provided mainly to control the depth of penetration

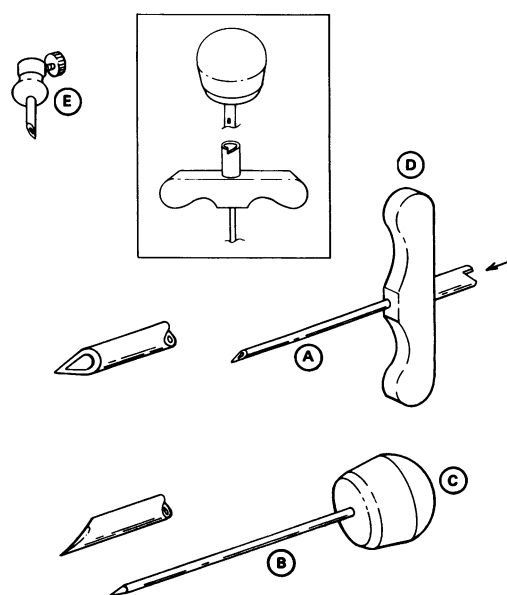

Figure 1 Needle (A), stilette (B), dome handle (C), the T-bar handle (D), and the guard (E). Inset shows the details of the luer-lock attachment of the needle and the handle. The sloped stop at the proximal end of the needle is shown by an arrow.

Department of
Hematologic
Oncology,
Roswell Park
Memorial Institute,
666 Elm Street,
Buffalo, New York,
NY 14263, USA
A Islam

Correspondence to:
Dr A Islam

Accepted for publication
7 February 1991

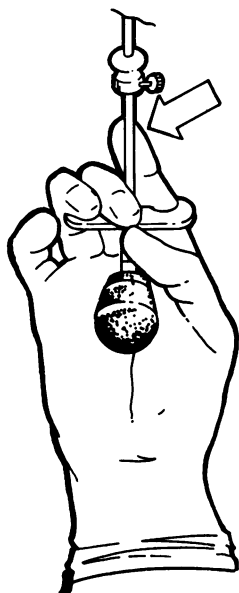

Figure 2 Diagrammatic representation of the position of the index finger over the shaft which helps stabilise the needle and permits enhanced control during the sternal puncture procedure.

during the sternal puncture and also as a precaution and protection against accidents. In obese patients, however, it may be necessary to remove the guard from the needle before attempting to enter the sternum. In such circumstances the positioning of the index finger over the shaft (fig 2) of the needle helps stabilise the needle and permits adequate control during the sternal puncture procedure.

ASPIRATION PROCEDURE

The patient is placed on his or her back with the head and neck comfortably rested on a soft low lying pillow. The region over the sternomanubrial junction including the area down to the fourth intercostal space in the midsternum is then prepared with alcohol and iodine. In adults the sternal puncture is performed in the upper part of the sternal body, at the level of the second intercostal space, half way between the midsternal line and the left sternal border. After sterilising the skin and local anaesthesia of the skin, subcutaneous tissue, and periosteum the needle with its stilette in place is slowly and gently advanced and directed towards the sternum with the index finger over the shaft (or over the appropriately adjusted and fixed guard) so as to hit the bone at a right angle (fig 2). When the sternum is reached it is then penetrated by gentle rotary motion of the needle. Entrance into the sternal marrow cavity is recognised by a "sudden" give of the needle which indicates that the outer table (anterior lamina of the sternum) has been perforated. Once the needle is in place in the marrow cavity the stilette is removed by anti-clockwise rotary motion of the dome handle, a tight fitting dry syringe (2.5 or 10 ml) is attached to the needle, and aspiration of 0.5 to 2.0 ml of marrow is performed. After aspiration the stilette is promptly replaced and the needle is withdrawn by firmly holding the shaft and bar together with the handle of the stilette. After withdrawal of the needle a firm pressure is applied for one or two minutes over the site of the puncture to stop any bleeding and then a small gauze dressing is applied.

Results

The needle has been extensively tested on cadavers. It has also been used in three medical centres. The operators have found the design and construction of the needle satisfactory and a considerable improvement over the conventional sternal puncture needle. They have also found the needle easy to manipulate and convenient to operate; patients have accepted its application without complaint.

Discussion

Since 1929, when Arinkin first introduced the technique of aspiration biopsy of sternal bone marrow,¹ sternal puncture has become one of

the most common intraosseous diagnostic procedures used in the field of haematology. Although the area in adults which yields the largest quantity of bone marrow is the posterior ilium, the sternum remains the most widely used site for obtaining bone marrow aspirate samples for marrow examination and haematological diagnosis. This preferential selection may be due to the fact that this is an area of functioning haematopoietic marrow which is near the surface of the body and is easily accessible.

The needles most commonly used for obtaining bone marrow aspirate samples from the sternum are the Salah and Klima needles. They were designed in the 1930s and except for the introduction of different kinds of stops and guards there has been very little change over the years in their basic structure and design. Inherent in the structure of these conventional sternal puncture needles, but almost totally unappreciated, is the fact that these instruments are very small and they do not fit snugly in the operator's hand. In addition, the absence of a T-bar handle makes their introduction into the sternum by twisting or rotary movement of the hand cumbersome and difficult.

The aspiration needle described here was designed to obtain bone marrow aspirate from the sternum and to overcome the inherent disadvantages associated with the conventional sternal puncture needles. The advantageous features of the new needle are as follows: (i) the carefully tooled bevelled sharp-pointed cutting tip of the stilette, and the needle easily penetrates the soft tissue as well as the bony cortex of the sternum; (ii) the large T-metal bar at the proximal end of the needle permits a secure and firm grip, while the smooth dome shaped handle fits snugly in the palm of the operator's hand; (iii) due to the configuration of the handle and its dome there is no discomfort even when forceful thrusting is necessary; (iv) the sloped stop at the proximal end of the needle facilitates easy locking of the stilette during the needle assembly, keeping both the bevelled edge of the needle and stilette in the same plane; (v) the latter device also helps smooth and easy unlocking and withdrawal of the stilette before aspiration; (vi) the adjustable guard can be fixed firmly at any point over the shaft of the needle and help prevent too deep penetration by the needle. Furthermore, this needle is larger and stronger and therefore more effective in obtaining bone marrow aspirates from the sternum than the conventional sternal puncture needles.

I thank Mr DR Bevan of Downs Surgical Ltd for his useful advice and keen interest in the development of this instrument. This work was carried out while the author was working at the Hammersmith Hospital, London.

- 1 Arinkin MJ. Intravital Untersuchungs Methodik des Knochenmarks. *Folia Haematol (Leipz)* 1929;38:233.
- 2 Limarzi LR. Diagnostic value of sternal marrow aspiration. *Illinois Medical Journal* 1939;75:38.
- 3 Rubenstein MA. The technique and diagnostic value of aspiration of bone marrow from the iliac crest. *Ann Intern Med* 1950;32:1095.