



# HHS Public Access

Author manuscript

*J Phon.* Author manuscript; available in PMC 2017 March 01.

Published in final edited form as:

*J Phon.* 2016 March ; 55: 149–181. doi:10.1016/j.wocn.2015.12.003.

## The role of prominence in determining the scope of boundary-related lengthening in Greek

**Argyro Katsika**

Haskins Laboratories, 300 George Street, Suite 900 New Haven, CT 06511, Tel.: + 1 203 865 6163, ext 269, Fax: + 1 203 865 8963, argyro.katsika@haskins.yale.edu

### Abstract

This study aims at examining and accounting for the scope of the temporal effect of phrase boundaries. Previous research has indicated that there is an interaction between boundary-related lengthening and prominence such that the former extends towards the nearby prominent syllable. However, it is unclear whether this interaction is due to lexical stress and/or phrasal prominence (marked by pitch accent) and how far towards the prominent syllable the effect extends. Here, we use an electromagnetic articulography (EMA) study of Greek to examine the scope of boundary-related lengthening as a function of lexical stress and pitch accent separately. Boundaries are elicited by the means of a variety of syntactic constructions. The results show an effect of lexical stress. Phrase-final lengthening affects the articulatory gestures of the phrase-final syllable that are immediately adjacent to the boundary in words with final stress, but is initiated earlier within phrase-final words with non-final stress. Similarly, the articulatory configurations during inter-phrasal pauses reach their point of achievement later in words with final stress than in words with non-final stress. These effects of stress hold regardless of whether the phrase-final word is accented or de-accented. Phrase-initial lengthening, on the other hand, is consistently detected on the phrase-initial constriction, independently of where the stress is within the preceding, phrase-final, word. These results indicate that the lexical aspect of prominence plays a role in determining the scope of boundary-related lengthening in Greek. Based on these results, a gestural account of prosodic boundaries in Greek is proposed in which lexical and phrasal prosody interact in a systematic and coordinated fashion. The cross-linguistic dimensions of this account and its implications for prosodic structure are discussed.

### Keywords

Prosodic boundaries; boundary-related lengthening; boundary-related shortening; gestural coordination; pauses; Articulatory Phonology; Greek

---

**Publisher's Disclaimer:** This is a PDF file of an unedited manuscript that has been accepted for publication. As a service to our customers we are providing this early version of the manuscript. The manuscript will undergo copyediting, typesetting, and review of the resulting proof before it is published in its final citable form. Please note that during the production process errors may be discovered which could affect the content, and all legal disclaimers that apply to the journal pertain.

## 1.0 Introduction

### 1.1 Prosodic boundaries, boundary-related lengthening and its scope

The aim of this paper is to examine the scope of the temporal effect of prosodic boundaries, called boundary-related lengthening, to determine the role of lexical and phrasal prominence in it, and to develop a theoretical account that captures it. Prosodic boundaries are essential for organizing speech, chunking it into units adequate for speech processing (production and perception) and language acquisition. They emerge from *grouping*, one of the two main functions of *prosody*, which is the component of grammar that organizes speech by encoding *grouping* and *prominence* (cf. Fletcher, 2010 for an overview). *Grouping* groups speech units together forming larger cognitive constituents. For instance, syllables are grouped together into words, words into phrases, and phrases into larger phrases. Prosodic boundaries usually separate constituents of the same type, like phrases from each other (see Selkirk, 1996 for a proposal in which some boundaries separate constituents of different types). *Prominence* marks syllables within words (i.e., stressed syllables) and words within phrases (i.e., accented words) as rhythmically or conceptually important relatively to their non-prominent counterparts.

Standard phonological theories view prosody as a hierarchical structure, with grouping and prominence arising from this organization (e.g., Beckman & Pierrehumbert, 1986; Hayes, 1989; Nespor & Vogel, 1986; Selkirk, 1984). Lower-level constituents (e.g., words) are grouped together forming higher-level constituents (e.g., phrases). Although the number of levels that the prosodic hierarchy of a language has is debated, there is general agreement on the need for at least a minor and a major phrase above the word level (see Turk & Shattuck-Huganagel, 1996 for an overview). Minor and major phrases are often referred to as *Intonational Phrases* (IP) and *intermediate phrases* (ip) respectively, adopting the terms proposed by the Autosegmental-Metrical model of intonational phonology (Beckman and Pierrehumbert, 1986; Pierrehumbert, 1980). As for prominence, lexical stress (lexical prominence) is marked for most languages at the prosodic word level, and accentuation (phrasal prominence) is marked at the intermediate phrase level mainly via specific pitch movements called *pitch accents*. Viewed that way, the role of prosody can be rephrased as encoding hierarchies of groupings and prominences.

Prosodic boundaries are associated with spatio-temporal, tonal and pausal events that characterize their strength, specifying therefore their prosodic level and grammatical and communicative function. On the spatio-temporal domain, boundary-adjacent articulations are temporally longer both pre- and post-boundary (often referred to as *boundary-related lengthening*), spatially larger, especially the first articulation post-boundary (referred to as *strengthening*), and with the temporal intervals corresponding to their duration overlapping less with each other across the boundary as opposed to their non boundary-adjacent counterparts (e.g., lengthening: Beckman & Edwards, 1992; Byrd & Saltzman, 1998; strengthening: Cho & Keating, 2001, 2009; Fougeron, 2001; Fougeron & Keating, 1997; Keating, Cho, Fougeron & Hsu, 2004; overlap: Byrd, 2000; Byrd, Kaun, Narayanan & Saltzman, 2000; Byrd & Saltzman, 1998). Acoustically, both phrase-final and phrase-initial segments are longer than phrase-medial ones (e.g., phrase-finally: Cooper & Paccia-Cooper,

1980; Klatt, 1975; Lehiste, 1973; Oller, 1973; Shattuck-Hufnagel & Turk, 1998; Turk, 1999; Turk & Shattuck-Hufnagel, 2007; Umeda, 1975; Wightman, Shattuck-Hufnagel, Ostendorf & Price, 1992; phrase-initially: e.g., Cho, McQueen & Cox, 2007; Klatt, 1975; Oller, 1973; Shattuck-Hufnagel & Turk, 1998; Tabain, 2003a). It is the magnitude of these spatio-temporal effects that marks boundary strength, since the effects increase cumulatively across the prosodic hierarchy, becoming larger the stronger the boundary (e.g., pre-boundary lengthening: e.g., Byrd, 2000; Byrd & Saltzman, 1998; Cambier-Langeveld, 1997; Cho, 2006; Tabain, 2003b; Tabain & Perrier, 2005; post-boundary lengthening: Byrd & Saltzman, 1998; Cho, 2006; Cho & Keating, 2001; Fougeron, 2001; Keating et al., 2004; Tabain, 2003b; pre-boundary strengthening: Fougeron & Keating, 1997; Keating, Wright & Zhang, 1999; Tabain, 2003b; post-boundary strengthening: e.g., Cho & Keating, 2001; Fougeron, 2001; Fougeron & Keating, 1997; Keating et al., 1999; Keating et al., 2004; Tabain, 2003b; overlap: Byrd, 2000; Byrd & Choi, 2006; Cho, 2004). The cumulative nature of boundary lengthening has also been detected acoustically (cf. Fougeron & Keating, 1997; Keating et al., 1999).

On the tonal domain, specific falling or rising pitch movements occur at the end of phrases belonging in high prosodic levels (cf. Silverman, Beckman, Pitrelli et al., 1992). The ones associated with intermediate phrases are called *phrase accents*, and the ones associated with intonational phrases are called *boundary tones*, using the terms introduced by Autosegmental Metrical Phonology. Since the end of an intonational phrase (higher in the hierarchy) always coincides with the end of an intermediate phrase (lower in the hierarchy), a boundary tone is always preceded by a phrase accent. A subset of strong, phrase-level, boundaries might also include pauses. These are heard as silences. In terms of articulation, the small number of studies on the issue indicates that grammatical pauses (contrasted to ungrammatical ones, such as hesitations) involve articulatory configurations (Gick, Wilson, Koch & Cook, 2004; Katsika, Krivokapi, Mooshammer, Tiede & Goldstein, 2014, the latter being complementary study to the current one) with stable spatial and velocity characteristics (Ramanarayanan, Byrd, Goldstein & Narayanan, 2010; Ramanarayanan, Bresch, Byrd, Goldstein & Narayanan, 2009; Ramanarayanan, Goldstein, Byrd, & Narayanan, 2013) and which are regularly timed with respect to boundary tones (Katsika et al., 2014) (see Krivokapi, 2014 for an overview).

Our focus here is on the scope of boundary-related lengthening, i.e., the temporal interval over which the effect extends pre- and post-boundary including pauses. Although the effect itself is broadly attested and its scope is considered not to vary with prosodic level (cf. Cambier-Langeveld, 1997; Katsika, 2009), the exact domain of the affected speech and whether and how this is affected by prominence (lexical or phrasal or both) is not well understood.

Pre-boundary, a large number of studies targeted phrase-final words of different number and structure of syllables in different languages and language varieties using different types of measures, such as acoustic or articulatory (e.g., acoustic studies: British English: Campbell & Isard, 1991; American English: Nakatani, O'Connor & Aston, 1981; Oller, 1973; Turk & Shattuck-Hufnagel, 2007; British English: White, 2002; Dutch: Cambier-Langeveld, 1997; Hebrew: Berkovits 1993a, 1993b, 1994; Estonian: Krull, 1997; Greek: Katsika, 2009;

articulatory studies (all on American English): Beckman & Edwards, 1992; Byrd, 2000; Byrd, Krivokapi & Lee, 2006; Byrd, Lee, Riggs & Adams, 2005; Byrd & Saltzman, 1998; Edwards, Beckman & Fletcher, 1991; Krivokapi, 2007a). The largest and most reliable part of boundary-related lengthening was detected on the rhyme of the phrase-final syllable. Moreover, the duration of that rhyme was found to be more important for perceiving prosodic boundaries in comparison to other candidates, such as the phrase-final foot (Wightman et al., 1992). Turning back to speech production, additional, but smaller, systematic effects were observed earlier than the final rhyme. In particular, lengthening extended to the onset of the final syllable when the final vowel was short (not a diphthong or reduced) (Cambier-Langeveld, 1997; Oller, 1973) or when lexical stress was not final (Oller, 1973). With respect to stress, there are additional indications that boundary-related lengthening could extend further away from the boundary, reaching the stressed syllable (e.g., Berkovits, 1994; Krull, 1997; Nakatani et al., 1981), even when the stress was more than two syllables away from the boundary (e.g., acoustics: Turk & Shattuck-Hufnagel, 2007; White, 2002; articulation: Byrd & Riggs, 2008). The limited research on the effect of remotely positioned stress on the scope of phrase-final lengthening so far is inconclusive. The effect yielded one domain of boundary-related lengthening extending from the coda of the stressed syllable to the boundary in British English (White, 2002), but two separate domains, naming the rhyme of the final syllable and the rhyme of the stressed syllable (with any intervening syllables remaining unaffected), in American English (Turk & Shattuck-Hufnagel, 2007 and replication by Rusaw, 2011, 2013; see also Shattuck-Hufnagel & Turk, 1998; Turk, 1999). It needs to be noted however that the amount of lengthening detected on the syllable intervening between the stressed and final syllables in British English was substantially small (approximately 10 ms). Further research in American English via articulatory data found speaker-specific effects of stress on the scope of boundary lengthening, but not systematic boundary-related lengthening within the stressed syllable when the latter was not phrase-final (Byrd & Riggs, 2008; see also Riggs & Byrd, 2011). Given that only consonantal articulations were examined in these studies, the possibility of articulations involved in the stressed vowel being systematically lengthened across speakers remains open. Speaker idiosyncrasies were also detected via acoustic measures in Greek, in which boundary lengthening reliably affected the phrase-final syllable and extended towards the stressed syllable on a speaker-specific basis (Katsika, 2009). A systematic effect of stress was not found in German, in which the whole phrase-final word lengthened acoustically as a function of boundary regardless of stress position (Silverman, 1990; see also Kohler, 1983).

Post-boundary, the scope of the effect has not received a lot of attention. So far, a series of studies, mainly articulatory, indicate that lengthening is limited to the initial segment (Byrd et al., 2006; Byrd & Saltzman, 1998; see also Bombien, Mooshammer, Hoole & Kühnert, 2010, and Cho & Keating, 2009; see also Katsika, 2009 (acoustic)). This pattern is independent from the position of stress within the phrase-initial word, with any such effects of stress being speaker-specific (Byrd & Riggs, 2008). An interaction between stress and post-boundary lengthening, this time cross-boundary, is reported in an acoustic study of American English (Shattuck-Hufnagel & Turk, 1998). This study, which examined one speaker's reiterant speech, found phrase-initial lengthening only when the pre-boundary final syllable was stressed. The effect was limited to the initial syllable and was larger on the



onset than the rhyme. Related to the scope of post-boundary effects, articulations following the initial syllable have been found to present small, but systematic, effects of shortening, considered compensatory in nature (Byrd et al., 2006).

In addition to the general patterns and stress-related speaker idiosyncrasies described above, there is large cross-speaker variation in the scope of boundary-related lengthening (e.g., Byrd et al., 2006; Byrd et al., 2005; Krivokapi , 2007a). Furthermore, given that most studies use a restricted set of materials, the material-specific patterns of boundary-related lengthening are not yet known. Regardless of what the scope of the effect is, most evidence concurs in that it is manifested in a progressive manner, decreasing with distance from boundary (e.g., Berkovits, 1993a, b, 1994; Cambier-Langeveld, 1997; Campbell & Isard, 1991; Nakatani et al., 1981; Oller, 1973, White, 2002).

With respect to inter-phrasal pauses (for an overview see Krivokapi , 2014), their duration was found to increase with prosodic complexity or boundary strength (Krivokapi , 2007b; Krivokapi & Byrd, 2012; see also Katsika, 2009) and with the length of the surrounding phrases (Ferreira, 1991; Fuchs, Petrone, Krivokapi & Hoole, 2013; Krivokapi , 2007a, b; Wheeldon & Lahiri, 1997). Pausal duration was also affected by complexity of syntactic structure (e.g., Ferreira, 1991).

To summarize, previous research has not conclusively identified and has not yet accounted for the patterning of boundary-related lengthening. The effect is systematic immediately preceding and following the boundary, with more remote manifestations possibly being specific to the language or the speaker. Nevertheless, the position of lexical stress in the vicinity of boundaries emerges as a possible determining factor. It is yet to be determined whether this is purely an effect of lexical stress or an effect of pitch accent instead. Most previous studies did not separate the lexical from the phrasal aspect of prominence. To our knowledge, Turk and Shattuck-Hufnagel (2007) is the only study that considered lexical stress separately from pitch accent, and concluded that it is the lexical aspect of prominence that was of relevance. No decisive generalizations can be drawn though, since this part of their analysis included only disyllabic words spoken by one speaker. Furthermore, it still remains to be assessed how far the effect extends after the final pre-boundary prominent syllable. Does it cross the boundary, especially when inter-phrasal pauses are involved? Are the pauses themselves affected?

To specifically address these issues, the current study focuses on Greek, a language in which lexical stress is used contrastively. Our earlier acoustic research on the scope of boundary-related lengthening as a function of prominence position in Greek detected systematic lengthening on the boundary-adjacent segments, speaker-specific interactions between prominence and boundary-related lengthening, and longer pause durations the stronger the boundary (Katsika, 2009). However, that study did not distinguish between lexical stress and pitch accent, and did not control for intonation. Here, we consider Electromagnetic Articulography data to systematically examine across a wide range of intonational contours what the role of both lexical prominence (stress) and phrasal prominence (pitch accent) is in influencing the scope of boundary-related lengthening, including how long in advance of a phrase edge these effects are initiated and their relation to inter-phrasal pauses. Pauses were

not targeted by design, but were included in our investigation since the majority of the elicited boundaries contained pauses, which were also related to specific articulatory configurations. In light of these data, we also assess whether the effect extends over a continuous domain or not, and whether it does so progressively. Discussion of these issues is bridged with results of our complementary work on the coordination of boundary tones in Greek (Katsika et al., 2014). Our ultimate goal is to develop a theoretical account of the temporal dynamics of prosodic boundaries able to accommodate both typological variation and speaker idiosyncrasies, offering a better understanding of the human speech production system, language and cognition. In doing so, we also provide one of the first set of articulatory data on prosody in Greek. The hypotheses tested along with their expected outcomes are described in Section 1.4, after Articulatory Phonology, the theoretical framework adopted here, and Greek prosody are introduced in Sections 1.2 and 1.3 respectively.

## 1.2 Articulatory Phonology

This work is couched within Articulatory Phonology (e.g., Browman & Goldstein, 1992; Goldstein, Byrd & Saltzman, 2006) and its Task-Dynamics computational implementation (e.g., Saltzman & Munhall, 1989; Nam & Saltzman, 2003; Saltzman, Nam, Krivokapi & Goldstein, 2008). Within this framework, phonology and phonetics are isomorphic and linguistic entities result from dynamic systems. Phonological representations are composed of linguistically relevant gestures that control the speech organs called *gestures*. There are three types of gestures: *constriction*, *tone* and *clock-slowing* gestures.

Constriction and tone gestures are specified for abstract linguistics tasks, are realized by coordinated actions of specific articulators, have spatio-temporal properties, and are triggered by internal oscillators that are coupled to each other either in-phase (synchronously) or antiphase (sequentially) (constriction gestures: e.g., Goldstein, Byrd, & Saltzman, 2006; lexical tone gestures: Gao, 2008; see also Mücke, Nam, Hermes & Goldstein, 2012 for pitch accents, and Katsika et al., 2014 for boundary tones). Constriction and tone gestures differ from each other in that they involve different articulators and are specified for different tasks. Constriction gestures involve coordinated actions of the jaw, lips, tongue, velum and glottis in order to achieve specific constriction locations and degrees (e.g., labial closure). Tone gestures, on the other hand, engage the coordination of the lungs, the trachea, the larynx and a number of muscles, such as the thyroarytenoid, cricoarytenoid and cricothyroid muscles (cf. Hirose, 2010) in order to achieve linguistically relevant variations in the frequency of vibration of the vocal folds (i.e., the task of tone gestures is specified at the F0 space, e.g., low F0 or high F0) (Gao, 2008; cf. Fougeron & Jun, 1998; McGowan & Saltzman, 1995).

Clock-slowing gestures (e.g., Byrd & Saltzman, 2003; Saltzman et al., 2008) are substantially different from constriction and tone gestures in that they are not related to specific articulators, and consequently, they lack spatial properties. Their task is to achieve linguistically relevant modulations of the spatial and temporal properties of the constriction gestures, and presumably of the tone gestures as well, that are coactive with them. The scope of their effects is determined on the basis of two dimensions: 1) the coordination of clock-

slowing gestures with the other gestures, and 2) the temporal interval during which they are active. Both of these dimensions are currently not clearly defined due to the limited amount and complex nature of empirical data. The first type of clock-slowing gestures proposed was  $\pi$ -gestures, which are activated at prosodic boundaries, and their task is to locally slow down the central clock that determines the global speech pace (Byrd & Saltzman, 2003; see also Byrd, 2000; Byrd et al., 2000). The amount of slowing is proportional to their maximum activation level determined by the strength of the prosodic boundary, and their extent over time by their activation interval. Figure 1 schematically represents a  $\pi$ -gesture overlapping with the constriction gestures spanning a prosodic boundary.

As the figure shows,  $\pi$ -gestures act locally at the boundary, over a continuous activation interval, and their activation shape is such that the maximal effects occur close to the boundary, and decrease with distance from it. Finally, boundaries of different strengths are not different in type of effect, only in degree. These properties capture the empirical findings that constriction gestures adjacent to boundaries become longer, larger and further apart, and that these effects extend over a continuous domain in a progressive (i.e., decreasing with distance from boundary) and cumulative (i.e., increasing with boundary strength) manner (Byrd & Saltzman, 2003). The temporal initiation of these effects depends on the coordination of  $\pi$ -gestures with the other gestures. The original proposal was that  $\pi$ -gestures are coordinated with the edge of the phrase (Figure 2a), with this coordination being flexible, meaning that “*the prosodic events may overlap the segmental events and need not precisely share an edge with an individual gesture, segment, syllable or phrase*” (Byrd & Saltzman, 2003, p. 161). According to Byrd & Riggs (2008), if empirical data show that prominence plays a role in the initiation time of the boundary effects, the  $\pi$ -gesture model will need to adjust in one of the following two ways: i) the  $\pi$ -gesture is shifted as a whole towards the prominent syllable (*coordination shift*; Figure 2b), or ii) the edge of the  $\pi$ -gesture extends towards the prominent syllable and its activation interval becomes longer (*extension*; Figure 2c).

Recently, the concept of clock-slowing gestures has expanded to capture prominence-related effects as well (Saltzman et al., 2008). The newly revised clock-slowing gestures are called  $\mu$ -gestures, standing for modulation gestures. For historical reasons, the boundary-related gestures are still referred to as  $\pi$ -gestures, and the name  $\mu$ -gestures is reserved here for the prominence-related gestures. With this definition,  $\mu$ -gestures are active during prominence (lexical or phrasal) and, like  $\pi$ -gestures, control the spatio-temporal profile of the gestures that are co-active with them. This type of clock-slowing gestures (i.e., the  $\mu$ -gestures) were proposed along with a network of hierarchically nested coupled oscillators standing for prosodic levels (Saltzman et al., 2008). However, the current version of the model has not yet incorporated most of the prosodic effects, including boundary-related lengthening, as resulting from this nested hierarchy. For this reason, this network is not further discussed here.

### 1.3 Greek prosody

This section summarizes some aspects of Greek prosody that are relevant for this study (see Arvaniti, 2007 for an overview). Two phrasal levels have been assumed for Greek, naming

intermediate phrases (ip) and Intonational Phrases (IP) (Arvaniti & Baltazani, 2005). These are associated with specific phrase accents and boundary tones respectively (see Arvaniti & Baltazani, 2005 for a complete list). They also present boundary-related lengthening in a cumulative fashion, meaning the amount of lengthening is larger in IP (higher level) than in ip (lower level) (Kainada, 2007). The current study examines the scope of that lengthening as a function of lexical stress and nuclear pitch accent (i.e., the last pitch accent of a phrase). In Greek, lexical stress is placed in one of the final three syllables of the word, and is unpredictable and contrastive (e.g., [ti' lɛ fɔ nɛ ] “phones, n.” – [tɪɛ ' fɔ nɛ ] “call, 2<sup>nd</sup> person imp.” – [tɪlɛ fɔ ' nɛ ] “3<sup>rd</sup> person ind.”). The main phonetic correlates of Greek stress are duration and amplitude (see Arvaniti, 2007 and references therein). Following the Tone and Break Indices system (ToBI) notation (English: Silverman et al., 1992; Greek: Arvaniti & Baltazani, 2005), nuclear pitch accents are either singleton tones (L\* or H\*) or bitonal tones (L+H\* or H\*+L), related to the stressed syllable of the accented word. Specifically, the F0 peaks of the H\* and L+H\* and the F0 minimum of L\* co-occur with the stressed vowel, while the F0 peak of the H\*+L occurs just before the stressed syllable (Arvaniti & Baltazani, 2005; Arvaniti, Ladd & Mennen, 2006b).

#### 1.4 Hypotheses and predictions

This Electromagnetic Articulography study examines the scope of boundary-related lengthening (including any pauses) as a function of lexical stress and pitch accent in Greek. In other words, the following questions need to be answered: 1) When is the effect initiated, 2) when is the effect terminated, 3) does the initiation and termination of the effect and/or the temporal profile of pauses depend on the position of lexical stress or pitch accent, and 4) does the effect stretch continuously between its onset and its offset?

Here, we define the initiation of boundary-related lengthening as coinciding with the most distant constriction gesture before the boundary undergoing the effect. Due to the complex nature of previous findings, it is difficult to formulate a concrete prediction as to when this initiation might occur. Grounded on evidence from our preliminary acoustic study (Katsika, 2009), it is expected that in Greek boundary-related lengthening be initiated within the boundary-adjacent syllable (see similar findings in English e.g., Byrd et al., 2006; Krivokapi, 2007a; Wightman et al., 1992), with initiation within the earlier prominent syllable of the phrase-final word being speaker-dependent (also in agreement with Byrd & Riggs, 2008; Riggs & Byrd, 2011). However, this does not preclude the possibility of the effect being initiated closer to, but possibly not within, the prominent syllable (not including the prominent syllable, with the patterns being speaker-specific: Byrd & Riggs, 2008; Riggs & Byrd, 2011; including the prominent syllable: Turk & Shattuck-Hufnagel, 2007; White, 2002). Compared to acoustic data, articulatory data allow a finer segmentation of the consonants and the vowels, and such a subtle systematic effect of prominence on boundary-related lengthening could be detected. It is not clear, however, whether this effect would be due to lexical stress or to pitch accent, despite some indications supporting the former (Turk and Shattuck-Hufnagel, 2007). It is unlikely that in Greek boundary-related lengthening is initiated upon the onset of the phrase-final word, as assumed to be the case in German (Kohler, 1983; Silverman, 1990).

The termination of the boundary-related lengthening is taken to be the last constriction gesture affected after the boundary. The majority of previous studies concur that lengthening does not stretch long after the boundary, but remains local within the phrase-initial syllable, especially within its first segment, with more remote expressions of the effect being speaker-dependent (e.g., Byrd et al., 2006; Byrd & Riggs, 2008; Byrd & Saltzman, 1998; Krivokapi, 2007a). However, there is acoustics-based evidence suggesting that boundary lengthening appears post-boundary only if the last pre-boundary prominence is on the phrase-final syllable (Shattuck-Hufnagel & Turk, 1998). If this is indeed the case, then the offset of boundary will be located pre-boundary, and its extension post-boundary will be considered conditioned by prominence. It cannot be predicted yet whether this conditioning, if detected, will be stress- or pitch accent-driven.

In order to examine whether boundary lengthening affects a continuous interval of speech, all the constriction gestures that undergo the effect need to be detected. Clear predictions cannot be drawn as to whether the effect would extend over a continuous domain (cf. White, 2002) or not (cf. Turk & Shattuck-Hufnagel, 2007; and replication of this study by Rusaw, 2011, 2013). The effect is predicted to be progressive, i.e., decreasing with distance from the boundary (e.g., Berkovits, 1993a, b, 1994). Continuity and progressiveness are also in accordance with the predictions of the  $\pi$ -gesture model (Byrd & Saltzman, 2003).

As for pauses, no specific predictions on their relation with stress and pitch accent can be induced due to absence of previous research on the matter.

## 2.0 Methods

### 2.1 Participants

This study had eight (5 female, 3 male) participants, ages between 19 and 31. All participants were native speakers of standard Greek, who at the time of their participation were associates of Yale University and had been in the United States of America between 1 and 6 years. They were naïve to the purpose of the study and had no self-reported speech, hearing or vision problems. Participants gave informed consent and received financial compensation for their participation. The Yale University Human Investigation Committee approved the protocols reported here.

### 2.2 Experimental design and stimuli

To detect the scope of boundary lengthening two BOUNDARY conditions were compared to each other, namely intonational phrase (IP) boundaries were compared to word (W) boundaries (see Figure 3 and Table 1 for a summary of the experimental design and a list of the stimuli). The stimuli of the IP set consisted of two sequential intonational phrases, referred to as IP<sub>1</sub> and IP<sub>2</sub>. In the W set, the stimuli consisted of single intonational phrases, used as controls for the IP set. The scope of boundary lengthening was examined over the final word of IP<sub>1</sub> and the initial word of IP<sub>2</sub>. These words were phrase-medial and consecutive in the W condition. To examine the effect of pre-boundary lexical stress (STRESS) on the scope of boundary lengthening, the IP<sub>1</sub>-final word was one of the following neologisms: *MAmima*, *maMima* and *mamiMA* (capital letters stand for lexical stress).

These neologisms compose a stress minimal set, consisting of identical sequence of segments but stressed contrastively in one of the following ways:

1. On their first syllable, i.e., the antepenult, yielding stress-initial words (S1).
2. On their second syllable, i.e., the penult, yielding stress-medial words (S2).
3. On their third syllable, i.e., the ultima, yielding stress-final words (S3).

Neologisms were used to minimize constriction gesture variability while ensuring F0 continuity and optimizing articulator traceability<sup>1</sup>. Each neologism stood for a different narcotic plant. This meaning was chosen in order to suit the context of all the types of stimuli sentences used, described in detail below. The participants learnt these meanings during the training session that preceded the experiment by one to three days by the means of example sentences. Other than the IP<sub>1</sub>-final words, the stimuli contained real words of Greek.

To assess a possible effect of the lexical stress of the pre-boundary word on the scope of lengthening post-boundary, the trisyllabic word metaKSI (“among”, capital letters represent the lexically stressed syllable) was used IP<sub>2</sub>-initially across all stimuli. This word was selected because it is stressed on the ultima ensuring maximum distance of the stress from the preceding boundary, and due to the sequence of consonants of different place of articulation (i.e., /m/, /t/ and /ks/), which adds articulatory variability by being very different from the immediately preceding test word, while guaranteeing three clear consecutive articulatory targets (i.e., labial vs. tongue tip vs. tongue dorsum constriction). However, this implies that the V constrictions of metaKSI are formed by the same speech organ as two of its C constrictions, involving thus a great amount of coarticulation.

To examine the role of pitch accent (ACCENT) and disentangle it from that one of lexical stress (STRESS), two sets of syntactic constructions were used for eliciting IP<sub>1</sub>, one set in which the IP<sub>1</sub>-final word was accented (A) and another one in which it was de-accented (D) (see Figure 3 and Table 1). Specifically, following Greek ToBI (Arvaniti & Baltazani, 2005), affirmative declaratives (AD), yes-no questions (YNQ), causative clauses (CC) and parenthetical clauses (PC) were used for eliciting accented IP<sub>1</sub>-final words, and negative declaratives showing reservation (ND), wh-questions (WhQ) and imperative requests (IR) were used for eliciting de-accented IP<sub>1</sub>-final words. The boundaries elicited by the accented set (A) differ both in terms of intonation and in terms of impressionistic strength. With respect to intonation, affirmative declaratives and parenthetical clauses involve a L-L% combination of phrase accent and boundary tone, yes-no questions a H-L% combination, and causative clauses a L-H% combination (see Arvaniti & Baltazani, 2005). As for boundary strength, affirmative declaratives and yes-no questions are produced with a

<sup>1</sup>The neologisms used nasals as consonants to ensure F0 continuity. The labial nasal /m/ was preferred to the coronal /n/, so that the articulators responsible for the consonants and the vowels used different speech organs (lips vs. tongue). In that way, the articulators were traceable while co-articulation effects were minimized. The alternation between the high-front vowel /i/ and the mid/low-back vowel /a/ ensured that the vocalic constriction targets were as far apart as possible, and thus the articulatory movement from one vowel to the other could be clearly tracked.



stronger IP boundary than causative clauses and parenthetical clauses, as corroborated by the fact that the two latter types correspond to subordinate clauses and are represented in the orthography with a comma. The three de-accented constructions, on the other hand, involve the same intonation contour (L-H\* L-!H%; see also Arvaniti & Baltazani, 2005) and the same strength of boundary. Three additional sets of stimuli were used to elicit the control W boundary conditions (i.e., with no IP boundary between the two test words). Specifically, a set of affirmative declaratives and a set of negative declaratives showing reservation were used to elicit the IP<sub>1</sub>-final words of the IP set in accented and de-accented phrase-medial positions respectively, while another set of affirmative declaratives were used to elicit the IP<sub>2</sub>-initial words of the IP set in accented phrase-medial positions. In all 10 constructions employed, the last pitch accent of the phrase, namely the nuclear accent, denotes broad focus.<sup>2</sup> The experimental design is summarized in Figure 3.

Hence, ten stimuli sentences were employed for each member of the stress minimal triplet (i.e. *MAmima*, *maMIma*, and *mamiMA*), yielding 30 stimuli in total. In all stimuli, seven syllables preceded and thirteen syllables followed the neologisms, with the two syllables neighboring the neologism on each side being unstressed. Contextualizing sentences were employed in order to elicit the expected intonation contour for all constructions except yes-no questions and causative clauses, for which context was not necessary.

Table 1 lists the stimuli for the stress-initial IP<sub>1</sub>-final words (i.e., SI: *MAmima*). For stress-medial (S2: *maMIma*) and stress-final (S3: *mamiMA*) test words, the same sentence frames were used. Nine blocks of the test material were constructed, each containing one repetition of the thirty test sentences in a randomized order, summing up to 270 sentences per participant.

### 2.3 Apparatus and recording procedure

For the experiment, the AG500 three-dimensional electromagnetic transduction device (Carstens Medizinelektronik) at the physiology lab at Haskins Laboratories was used. Five receiver coils were attached to areas of interest, namely the tongue dorsum, tongue body, tongue tip, upper lip and lower lip. Six additional receiver coils were attached to reference points, and specifically to the upper incisor, left and front sides of the jaw, left and right ears, and nose. Each experimental session was preceded by the standard calibration procedure, as developed by Hoole, Zierdt and Geng (2003). Acoustic data were acquired along with the articulatory data using a Sennheiser shotgun microphone at a sampling rate of 16 kHz. The microphone was positioned roughly 12 inches away from the participant.

The participants received training familiarizing them with the neologisms, the targeted intonational contours, and the stimuli presentation 1–3 days before the experimental session. The training session lasted 20–30 minutes. The experimental session lasted between 2 and 3 hours, and included coil attachment, review of the instructions for the task, practice trials, data acquisition, breaks, and coil removal. Both the instructions and the speech materials

<sup>2</sup>A subset of the constructions involving an IP boundary was used to examine the coordination of boundary tones. These were the yes-no questions, the causative clauses, the negative declaratives, the wh-questions and the imperative requests. In these constructions, the combination of phrase accent and boundary tone involved alternating tones detectable at F0 inflection points. The results of this analysis are reported and discussed in Katsika et al. (2014).

were presented on a computer screen, using custom software (developed by Mark Tiede, Haskins Laboratories). The computer monitor was placed around 60 inches away from the participant. The participants were instructed to pay attention to the position of lexical stress on the test words (Greek orthography has a specific symbol (´ ´) for stress, e.g., *μάμιμα*, *μαμίμα*, *μαμιμά*), the punctuation signs, which indicated the phrasing of the sentences, and the words in bold, which denoted that these words were bearing the main information of the sentence. As for the presentation of the stimuli, context sentences appeared first in green letters. Some seconds later their respective target sentence appeared in blue letters. The participants read the context sentences silently and the target ones aloud at their normal speech rate. Sentences produced with speech errors, interruptions or disfluencies were repeated. In order to minimize head movement, participants were shown a real-time display of upper incisor position.

## 2.4 Analysis

The TAPADM (Three-dimensional Articulographic Position and Align Determination with MATLAB™, developed by Andreas Zierdt) pre-processing procedure was applied to the data (cf. Hoole et al., 2003). This procedure smoothens, corrects and translates the data to the occlusal plane, and also functions as a checking method for the reliability of the data. In parallel, the data were subject to a preliminary acoustic inspection to determine whether they were produced with the targeted F0 contour. These two sets of analyses combined revealed that the datasets from three participants were not eligible for further analysis due to the amount of dropped or noisy data from at least one receiver coil (one speaker) or inadequate F0 production (two speakers). The remaining five participants are referred to as F01, F02, F03, F04 and M05 (four female and one male). From the data acquired from these five participants less than 3% were eliminated from the analysis due to abnormalities in their displacement or velocity signal. The data were further examined for their prosodic boundaries using GrToBI (Arvaniti & Baltazani, 2005), on the basis of which some tokens were excluded from further analysis because they were lacking a boundary where expected. For instance, speaker F04 did not produce prosodic boundaries in the parenthetical clause condition. With the exception of F04's parenthetical clauses, the analysis included between 5 and 15 tokens per STRESS condition in each syntactic construction per speaker. Thus, some conditions included more than 9 tokens, which, as a reminder, was the number of repetitions required for each sentence by the experimental design. This is because in some cases additional repetitions were acquired for a variety of reasons (e.g., resumption of the recording after interruption due to software error or after the participant's request for a break).

The resulting datasets were subject to semi-automatic kinematic labeling using custom software (Mark Tiede, Haskins Laboratories). Specifically, the consonant (C) and vowel (V) constriction gestures comprising the last pre-boundary word (i.e., MAmima, maMIma or mamiMA) and the C gestures of the first post-boundary word (i.e., metaKSI) of each token were labeled, where boundary is either an Intonational Phrase (IP) boundary or a word (W) boundary. Pre-boundary, both the C and the V gestures were labeled, because each type of gesture involved a different principle articulator (the C gestures used the lips while the V gestures used the tongue dorsum), and thus their targets could be clearly located. Post-

boundary, only the C gestures were labeled, because the experimental design involved different articulators for each consonant (lips for /m/, tongue tip for /t/, and tongue dorsum for /ks/) but allowed a greater amount of coarticulation between the V and the non-labial C constrictions. It is thus acknowledged that the measures taken from post-boundary non-labial C constrictions include the co-articulatory contribution of the neighboring V constriction. However, this does not influence our analysis since the comparison is between the two boundary (IP and W) counterparts of the same constriction. The labial C gestures (/m/) were labeled on the lip aperture tract, the coronal C gestures (/t/) on the tongue tip vertical displacement tract, and the velar C gestures (/k/) along with the V gestures (/e, i, e/) on the tongue dorsum vertical displacement tract. The kinematic labels (shown in Figure 4) consisted of marking the following landmark timepoints for constriction formation of the C and V gestures: onset timepoint, peak-velocity timepoint, target timepoint, constriction maximum timepoint, and timepoint of release of constriction formation. Additionally, for the C gestures the constriction release phase of the gesture was also marked for the timepoint of peak velocity and timepoint of end of release (offset). These timepoints were identified on the basis of velocity criteria, i.e., velocity minima for constriction maxima and thresholds of velocity ranges between two consecutive alternating velocity extrema (i.e., one minimum and one maximum). These thresholds were set to 20%, except for the C onset and offset that were set to 10%, due to the small amplitude of lip aperture for the C constrictions (see Figure 5). The velocity of lip aperture was used for the labial consonants, and the tangential (xyz-) velocity for all the other constrictions. Using these timepoints, the duration of the formation and the release phases of each test C gesture and the duration of the formation phase of each V gesture was calculated. The duration of the release of V gestures was not calculated, because the release of a V gesture coincides with the formation of the following V gesture. As shown in Figure 4, formation is defined as the interval between the onset of the gesture and the release including the target, and release as the interval between the release and the offset of the gesture.

Figure 5 illustrates lip aperture (LA) and tongue dorsum vertical displacement (TDz) during pre- and post-boundary words. The example involves a de-accented (wh-question) phrase-final stress-medial (S2) word with the timepoints for the last pre-boundary C and V marked. The figure also contains a representative example of the articulatory configuration during acoustic pauses. It needs to be noted that this study was not designed to investigate pauses, but a large number of pauses was elicited, inspection of which revealed that they involve specific articulatory configurations, which we call here pause postures (PP). In these configurations, the tongue and the lips, after achieving the articulatory targets for the IP<sub>1</sub>-final C (/m/) and V (/e/), maintain for a substantial amount of time a position within the middle range of tongue dorsum vertical displacement and lip aperture respectively, before they move to a more extreme position, from which they start their opposite advancement towards their next constriction target in IP<sub>2</sub> (/m/ and /e/). The fact that articulators, after their middle-range long-lasting posture, reach a more extreme point, which is also in the opposite direction from their upcoming constriction target, suggests that this posture is not just preparatory for an upcoming event, but rather, is related to the pause itself. These properties generalize over speakers, pointing to a default, and possibly language-specific, articulatory setting during pauses (cf. Gick et al., 2004). Albeit not by design, we examined

the duration of the formation of these pause postures as a function of STRESS and ACCENT. PP formation was measured at the tongue dorsum vertical displacement as the interval between the offset of the phrase-final V gesture and the onset of the long-lasting plateau related to the acoustic pause. The onset of this plateau was detected using the same method as for V maximal constrictions described above and illustrated in Figure 4.

Two sets of analyses were conducted. One set, called within-speaker, treated each speaker separately due to the large number of speaker-specific properties reported in previous research (e.g., Byrd et al., 2006; Byrd et al., 2005; Krivokapi, 2007a). The other set of analyses, called across-speaker, focused on the effects that generalize across speakers. Both sets of analyses examined the accented constructions separately from the de-accented ones, since the control sentences were different for the two groups. The set of accented constructions included the data pooled from AD, YNQ, CC and PC, and the set of de-accented constructions included the data pooled from ND, WhQ and IR. The scope of boundary-related lengthening was assessed by examining which test gestures were longer in IP than in W in each Stress. To examine speaker-specific effects, planned comparisons via pair-wise t-tests ( $\alpha = 0.05$ ) between the two types of boundary (IP and W) were conducted for each speaker. For the effects generalized across speakers, we employed repeated measures ANOVAs on the duration of each test gesture with BOUNDARY (levels: IP and W) as the fixed factor and speaker (F01, F02, F03, F04 and M05) as the repeated factor. As for the speaker-specific properties of pauses, the durations of the PP formation of each speaker was subject to ANOVAs with STRESS (levels: S1, S2, S3) as factor. In cases in which the ANOVAs showed significant effects ( $\alpha = 0.05$ ), pair-wise comparisons using the Bonferroni adjustment followed up ( $\alpha = 0.05$ ). We also report comparisons with  $0.05 < \alpha < 0.07$  as marginally significant (m.s.). The generalized properties of PP formation were assessed by the means of repeated measures ANOVAs with STRESS (levels: S1, S2, S3) as the fixed factor and speaker (F01, F02, F03, F04 and M05) as the repeated factor. An additional set of analysis examined the durations of each test gesture and of the PP formation as a function of ACCENT. For this analysis, CC (causative clauses, i.e., one of the accented conditions) and D (all the de-accented constructions with an IP boundary) were used. Of the accented constructions, only CC was selected because of its similarity in terms of boundary-marking intonation with the D. The statistical analyses were carried out in the R statistical environment (R Development Core Team, 2013).

## 3.0 Results

### 3.1 Within-speaker analysis

**3.1.1 De-accented conditions**—Tables 2a and 2b contain the results of the within-speaker analysis for de-accented IP<sub>1</sub>-final words and their sequential IP<sub>2</sub>-initial words respectively. Table 3 juxtaposes the pre-boundary and the post-boundary results, summarizing these comparisons. The constriction gestures are given in the order the consonants and the vowels appear in the orthography of the test words. However, during speech there is substantial temporal overlap during speech between the C and V gestures belonging in the same syllable.

**Initiation of boundary-related lengthening:** As Tables 2a and 3 explicitly depict, lexical stress has an effect on the point in time that boundary-related lengthening is initiated. When stress is final (S3), the initiation of the effect occurs within the C and V gestures that are immediately adjacent to the boundary (C3-R and V3). These two gestures are partially co-produced, and thus, the initiation point of the effect can be considered to coincide with both of them. When stress is not final, on the other hand, the effect is initiated further away from the boundary, with its exact initiation point being speaker-specific and not necessarily within the stressed syllable itself. F04 is the only speaker whose boundary-related lengthening reaches back to the stressed syllable in both non-final STRESS conditions (S1 and S2). Note that Speaker F03, who initiates the lengthening slightly earlier (C3-F) within the phrase-final syllable of stress-final words (S3) as compared to the other speakers, still shows an earlier initiation of the effect in words with non-final stress (S1 and S2). The stress-affected pattern of boundary-related lengthening initiation holds for all speakers except F01, whose lengthening remains constant across STRESS conditions over the release of the final C and the final V (C3-R and V3).

**Termination of boundary-related lengthening:** Post-boundary, lengthening systematically affects the forming gesture of the word-initial C (C4), which is the gesture immediately adjacent to the boundary. This pattern is observed for all speakers except M05, who shows post-boundary lengthening only on the release of the phrase-initial C (C4-R) in S2. Some instances of post-boundary lengthening later than the phrase-initial C are observed. These are either on the release of the initial C (C4-R) or closer to lexical stress of the word (C5-R, C6-F or C6-R). Since instances of the latter type are relatively scarce, it can be concluded that the termination of boundary-related lengthening occurs within the phrase-initial syllable.

**Continuity of boundary-related lengthening:** Between the effect's initiation and termination points established above, lengthening can be considered extending over a continuous interval of speech, despite the small number of sporadic discontinuities observed. Pre-boundary, the three instances of discontinuity detected (i.e., F02's C3-F and F04's C2-R in S1 and F02's V2 in S2) can be disregarded, since the skipped is co-produced with a gesture that presents boundary-related lengthening (e.g., the formation gesture of the final consonant of F02 in S1 does not lengthen, but its coproduced vowels gesture does). Post-boundary, the rare instances of discontinuity might be possibly related to the lexical stress of the phrase-initial word, since in these cases the effect skips several gestures after the ones in the initial syllable and affects either the last gesture before the stressed syllable or the first gesture of that syllable. Future research systematically varying the position of the first post-boundary stress will assess the validity of this hypothesis. Note that speaker M05 presents a different type of discontinuity, in which the forming gesture of the initial C does not lengthen, but its subsequent release does. In this case, it is still the first C that lengthens.

**Boundary-related shortening:** Outside the scope of boundary-related lengthening, some gestures are also found to be shorter in IP than in W. This boundary-related shortening is rather unsystematic pre-boundary, but quite consistent post-boundary. Pre-boundary, the shortening effect is speaker-dependent, with usually no more than two speakers shortening

the same gesture. Although the gestures undergoing the shortening are not identical across speakers, they are all early in the word, away from the boundary. An interesting observation is that shortening tends to either start or end closer to the boundary as the stress is later in the phrase-final word. For example, for F01 shortening ends in the initial V (V1) in S1, in the medial C release (C2-R) in S2 and in the final C formation (C3-F) in S3. This observation suggests that stress has a similar effect on both lengthening and shortening, with both temporal effects being somewhat attracted towards the stressed syllable. Post-boundary, the boundary-related shortening effect is mainly detected on the formation of the second post-boundary C (C5-F). Instances of shortening further away from the boundary are observed, but they are scarcer (e.g., F02's C6-F in S1 and S2, F03's C6-F and F04's C6-R in S1).

To summarize, boundary-related lengthening is initiated within the phrase-final C and V gestures in words with final stress but earlier in words with non-final stress, and is terminated within the phrase-initial C gesture. The effect extends over a continuous interval of speech, outside of which, instances of boundary-related shortening are observed. Pre-boundary, boundary-related shortening tends to be attracted towards the stressed syllable. Post-boundary, it systematically occurs one syllable away from the boundary.

**3.1.2 Accented conditions:** The results of the within-speaker analysis for the accented conditions are presented in Tables 4a and 4b, and summarized in Table 5 (for within speaker comparisons for each accented condition separately, the reader is referred to Appendix A).

As these tables show, the same patterns hold for the accented constructions as for the de-accented ones with respect to all aspect of the boundary-related modifications assessed here.

**Initiation of boundary-related lengthening:** It is apparent from the tables (4a and 5) that the position of lexical stress plays a role in the initiation of the effect. Although the specifics are speaker-dependent, pre-boundary lengthening is initiated earlier in words with non-final stress than in words with final stress. The effect is limited to the boundary adjacent C releasing and V gestures (C3-R and V3) in words with final stress, and extends up to the releasing gesture of the onset consonant of the penultimate syllable (C2-R) in words with non-final stress. Like in the de-accented conditions, the effect of stress position does not hold for speaker F01, whose pre-boundary lengthening remains confined within the final C release and V gestures regardless of STRESS.

**Termination of boundary-related lengthening:** As Tables 4b and 5 illustrate, post-boundary lengthening is systematically found on the forming gesture of the initial C (C4-F), less consistently on the release of that initial C (C4-R) or on one of the gestures closer or on the stressed syllable of the phrase-initial word (C5-R or C6-F). Based on the systematic effects, it can be deduced that boundary-related lengthening is terminated within the phrase-initial syllable. Similar patterns were observed and similar conclusions were drawn with respect to the de-accented conditions.

**Continuity of boundary-related lengthening:** In accented constructions, similarly to the de-accented ones, boundary-related lengthening extends over a continuous interval of speech, with its starting point being dependent on the position of stress within the phrase-final word



and its ending point being the phrase-initial syllable. Some instances of discontinuity are observed, but they are sporadic and unsystematic.

**Boundary-related shortening:** Like in de-accented conditions, boundary-related shortening is detected outside the scope of lengthening. Pre-boundary, shortening is present early within the phrase-final word, albeit in a rather unsystematic way. For the speakers that present shortening, the effect is initiated within the formation of the first C (C1-F) in stress-initial words (S1), within the release of the first C (C1-R) or within the first (V1) in stress-medial (S2) and stress-final words (S3). These results, combined with similar findings in de-accented conditions, suggest that pre-boundary, the locus of the shortening effect, although not systematic, tends to be attracted to the position of stress. Post-boundary, like in the de-accented conditions, shortening is detected on the medial C gesture (C5) of the phrase-initial word across STRESS conditions. Shortening is observed on other post-boundary gestures as well, but very sporadically.

In sum, the boundary-temporal modifications occurring in the context of accented phrase-final words are similar to those occurring in the context of de-accented phrase-final words. Lengthening systematically affects the boundary-adjacent gestures, namely the release of the phrase-final C, the phrase-final V, and the formation of the phrase-initial C. The position of the phrase-final lexical stress affects the scope of lengthening pre-boundary, with the effect being attracted towards the stressed syllable in words with non-final stress, but not post-boundary. In parallel, tendencies of shortening are observed. Pre-boundary, shortening seems to be stress-related, being initiated or terminated close to the stressed syllable. Post-boundary, shortening remains on the formation of C of the medial syllable, independently of the position of lexical stress on the pre-boundary phrase-final word.

**3.2 Across-speaker analysis**—The results of the repeated measures ANOVAs that were conducted in order to detect which of the within-speaker patterns generalize across speakers and constructions are summarized in Figure 6 (for the respective figures per speaker the reader is referred to Appendix B).

As the figure illustrates, the main patterns detected by the within-speaker analysis are retained in the cross-speaker analysis, meaning the lexical stress-driven effect on lengthening and shortening pre-boundary, the consistent loci of lengthening and shortening post-boundary, and the continuous scope of the effect.

**Initiation of boundary-related lengthening:** In de-accented constructions, lengthening is limited to the last C and the last V gesture in stress-final words (S3: C3-R:  $F(1,4) = 21.98$ , V3:  $F(1,4) = 31.09$ ;  $p < 0.05$ ), but extends to the penultimate syllable in words with non-final stress ([S1: V2:  $F(1,4) = 6.907$ ,  $p = 0.058$  (m.s.); C3-F:  $F(1,4) = 12.33$ ,  $p < 0.05$ ; C3-R:  $F(1,4) = 106.2$ ,  $p < 0.05$ ; V3:  $F(1,4) = 77.71$ ,  $p < 0.05$ ]; [S2: C3-F:  $F(1,4) = 6.257$ ,  $p = 0.066$  (m.s.); C3-R:  $F(1,4) = 119$ , V3:  $F(1,4) = 12.73$ ;  $p < 0.05$ ]). In accented constructions, the effect of lexical stress on the initiation of boundary-related lengthening is preserved in stress-initial words (S1), but it disappears in stress-medial (S2) words. Specifically, in accented stress-final words (S3), boundary-related lengthening affects the boundary-adjacent C3-R ( $F(1,4) = 7.874$ ,  $p < 0.05$ ) and V3 ( $F(1,4) = 13.84$ ,  $p < 0.05$ ). The effect extends

towards the stressed syllable in stress-initial words (S1) reaching the V gestures of the penultimate syllable, exactly like in the de-accented constructions (V2:  $F(1,4) = 7.658, p = 0.05$ , C3-F:  $F(1,4) = 9.639$ , C3-R:  $F(1,4) = 27.73$ , V3:  $F(1,4) = 8.209; p < 0.05$ ). However, in stress-medial words (S2) boundary-related lengthening remains within the boundary-adjacent C and V gestures (C3-R:  $F(1,4) = 21.12$ , V3:  $F(1,4) = 15.04; p < 0.05$ ). Presumably, this is because in stress-medial words the accented penultimate undergoes accentuation-related lengthening confounding the boundary-related effect (see Section 3.3 for details on accentuation-related lengthening).

**Termination of boundary-related lengthening:** Phrase-initially, boundary-related lengthening systematically affects the forming gesture of the first C (C4-F) regardless of the pre-boundary position of lexical stress and/or pitch accent ([de-accented: S1:  $F(1,4) = 30.34, p < 0.05$ ; S2:  $F(1,4) = 19.49, p < 0.05$ ; S3:  $F(1,4) = 9.677, p = 0.05$ ]; [accented: S1:  $F(1,4) = 24.31, p < 0.05$ ; S2:  $F(1,4) = 22.68, p < 0.05$ ; S3:  $F(1,4) = 24.66, p < 0.05$ ]). Three rather unsystematic cases of lengthening after the initial C gesture are observed. In two cases, the releasing gesture of the first C (C4-R) lengthens as well (S1 in de-accented:  $F(1,4) = 35.4, p < 0.05$ ; S2 in accented:  $F(1,4) = 11.21, p = 0.05$ ). In the third case, the forming gesture of the last C (C6-F) lengthens in S2 in the accented constructions ( $F(1,4) = 5.166, p < 0.05$ ). The latter case might reflect an interaction between the boundary-related lengthening and the position of stress in the phrase-initial word, an issue that will be explicitly assessed in future research.

**Continuity of boundary-related lengthening:** As is clear from Figure 6, boundary lengthening affects a continuous interval of speech, starting from either the penult or the ultima depending on the position of stress within the phrase-final word and extending to the initial syllable post-boundary.

**Progressiveness of boundary-related lengthening:** Figure 6 also shows that when the effect extends further away from the final C and V gesture, it is progressive. This means that the amount of lengthening decreases with distance from the boundary. (The figures in the Appendix show that this pattern generalizes across speakers and constructions.)

**Boundary-related shortening:** Some gestures further away from the boundary are shorter in IP as compared to W. Pre-boundary, the distribution of these gestures is related to the position of lexical stress, which is especially apparent in the accented constructions. In stress-initial words (S1), it is only the first C gesture that lengthens (C1-F: de-accented:  $F(1,4) = 7.569, p = 0.05$ ; accented:  $F(1,4) = 11.71, p < 0.05$ ). In words with non-initial stress, shortening is observed later in the word reaching closer to the stressed syllable ([de-accented: S2: no shortening; S3: V1:  $F(1,4) = 28.02, p < 0.05$ ]; [accented: S2: C1-R:  $F(1,4) = 16.42, p < 0.05$ ; V1:  $F(1,4) = 22.26, p < 0.05$ ; S3: C1-F:  $F(1,4) = 27.18, p < 0.05$ , V1:  $F(1,4) = 21.56, p < 0.05$ ; V2:  $F(1,4) = 7.919, p < 0.05$ ]). Post-boundary, shortening is systematically detected on the forming gesture of the penult's C (C5-F) across STRESS and ACCENT conditions ([de-accented: S1:  $F(1,4) = 7.059, p = 0.05$ ; S2:  $F(1,4) = 13.12, p < 0.05$ ; S3:  $F(1,4) = 8.31, p < 0.05$ ]; [accented: S1:  $F(1,4) = 32.15, p < 0.05$ ; S2:  $F(1,4) = 5.002, p = 0.09$ ; S3:  $F(1,4) = 10.41, p < 0.05$ ]).

**3.3 Accentuation-related lengthening on the phrase-final words**—This section isolates the effect of pitch accent on the duration of boundary-adjacent constriction gestures by comparing the accented to de-accented phrase-final words by the means of repeated measures ANOVAs with ACCENT (levels: A, D) as the fixed factor and speaker as the repeated factor. Table 9 and Figure 7 summarize the results of this analysis. As a reminder, for this analysis the accented conditions are represented solely by causative clauses (CC), since this is the most similar accented construction to the de-accented ones in terms of intonation. Both CC and the de-accented constructions involve a boundary-related rising pitch movement at the end of the test words, and differ in that the test words bear a pitch accent in CC but not in the de-accented constructions. It needs to be noted, however, that in causative clauses (like in parenthetical clauses as well) this pitch accent is the nuclear accent of a subordinate clause, which might influence the amount of the accentuation-related lengthening in such clauses in comparison to main clauses, like the other accented constructions used here (affirmative declaratives and yes-no questions).

The analysis revealed that in words stressed on the initial syllable (S1), accentuation-related lengthening is detected mainly on that syllable (C1-F:  $F(1,4) = 14.37$ , V1:  $F(1,4) = 17.47$ ;  $p < 0.05$ ). A smaller amount of lengthening is also detected on constriction gestures comprising the medial syllable (C2-F:  $F(1, 4) = 20.42$ ,  $p < 0.05$ ; C2-R:  $F(1,4) = 6.429$ ,  $p = 0.06$  (m.s.)). Accentuation-related lengthening on the syllable following the stressed one has been described as the spillover effect in the literature (cf. Dimitrova & Turk, 2012). In stress-medial words (S2), the most amount of lengthening is found on the vowel of the stressed syllable (V2:  $F(1,4) = 10.89$ ,  $p < 0.05$ ), with the onset of the syllable also lengthening (C2-F:  $F(1,4) = 29.71$ ,  $p < 0.05$ ). The spillover effect is apparent in this case also, affecting C3-F ( $F(1,4) = 7.541$ ,  $p = 0.05$ ). In addition, the syllable preceding the stressed one shows small amount of lengthening (C1-F:  $F(1,4) = 23.29$ ,  $p < 0.05$ ; V1:  $F(1,4) = 6.198$ ,  $p = 0.07$  (m.s.)). In stress-final phrase-final words (S3), accentuation-related lengthening is small. In the stressed syllable, the releasing gesture of the onset C lengthens (C3-R:  $F(1,4) = 19.5$ ,  $p < 0.05$ ). A small amount of lengthening is also observed in the consonant of the preceding syllable (C2-F:  $F(1,4) = 5.878$ ,  $p = 0.07$  (m.s.); C2-R:  $F(1,4) = 10.19$ ,  $p < 0.05$ ).

For the purposes of this study, it is interesting to note that the most accentual lengthening is detected on the vowel of the stressed syllable in stress-medial words (V2 in S2), with the following C gesture (C3-F) undergoing a significant amount of lengthening as well. This accentual-related lengthening might account for the absence of boundary-related lengthening in these positions (see Section 3.2).

### **3.4 Duration of pause posture formation as a function of stress and accent**—

Figure 8 summarize the within-speaker (8a) and cross-speaker (8b) analyses on the duration of pause posture (PP) formation.

The within-speaker analysis by the means of ANOVAs for each speaker separately with STRESS (levels: S1, S2, S3) and ACCENT (levels: accented, de-accented) as factors performed on the duration (in ms) of PP formation showed a main effect of STRESS for all speakers (F01:  $F(2, 222) = 34442$ , F02:  $F(2, 199) = 49132$ , F03:  $F(2, 165) = 55994$ , F04:  $F(2, 169) = 28545$ , M05:  $F(2, 182) = 58949$ ;  $p < 0.05$ ). According to the followed-up pairwise

comparisons, PP formation is longer in stress-final (S3) than in stress-initial (S1:  $p < 0.05$ ) and stress-medial words (S2: F01, F02, F03 and M05:  $p < 0.05$ ; the effect is marginal for F04:  $p = 0.06$ ). The ANOVAs also revealed a main effect of ACCENT for speaker F03 ( $F(1, 165) = 13.613, p < 0.05$ ), with PP formation being longer in accented than in de-accented phrase-final words ( $p < 0.05$ ). An interaction effect between the two factors was detected for speakers F01 ( $F(2, 222) = 20553, p < 0.05$ ) and M05 ( $F(2, 182) = 8.289, p < 0.05$ ). For these speakers, a set of pair-wise comparisons per ACCENT condition and a set of pair-wise comparisons per STRESS condition were performed. It was shown that for speaker F01 the STRESS did not have a significant effect on the duration of PP formation in de-accented phrase-final words, but it did in accented phrase-final words, with pause postures formation being longer in stress-final (S3) than stress-initial (S1) ( $p < 0.05$ ) or stress-medial (S2) ( $p < 0.05$ ) words. Speaker M05 on the other hand presents shorter PP formation in stress-medial words (S2) than stress-initial (S1) ( $p < 0.05$ ) and stress-final (S3) words in the de-accented condition ( $p < 0.05$ ), while he shows the same pattern as the other speakers in the accented condition, in which PP formation is longer in stress-final (S3) words than in either stress-initial (S1) ( $p < 0.05$ ) or stress-medial (S2) ( $p < 0.05$ ) words. Moreover, longer PP formation is found in the de-accented condition than in the accented one in stress-initial words (S1) for speaker M05 ( $p < 0.05$ ) and in stress-medial words (S2) for speaker F01 ( $p < 0.05$ ). However, in stress-final words (S3), speaker F01 shows longer PP movements in the accented than in the de-accented condition ( $p < 0.05$ ).

The repeated measures ANOVAs with STRESS (levels: S1, S2, S3) and ACCENT (levels: accented, de-accented) as the fixed factors and speaker as the repeated factor confirmed the effect of the position of stress on PP formation ( $F(2, 20) = 33.039, p < 0.05$ ) such that PP formation is longer in words with final stress (S3) than in words with non-final stress (S1 and S2,  $p < 0.05$  for both), regardless of the accentual status (accented or de-accented) of the IP<sub>1</sub>-final word.

**3.4 Summary of results**—In Greek, the lexical stress of the phrase-final word affects the temporal profile of that word and the following pause, regardless of the presence or not of a pitch accent. Boundary-related lengthening is initiated within the final V gesture and the overlapping release of the onset C in words with final stress, but earlier in words with non-final stress, coinciding either with the formation of the final C or with the V gesture of the penultimate syllable, depending on the speaker. Boundary-related shortening, which is observed further away from the boundary, albeit sporadic and small in amount, is initiated and/or terminated close to the stressed syllable, and the most affected gesture either belongs to or is close to the stressed syllable. Finally, pause posture formation is longer in the context of stress-final words than either stress-medial or stress-initial words. Post-boundary, the effects are not affected by either the stress or the accentual status of the final word pre-boundary. Lengthening consistently affects the initial C, especially its formation phase, and shortening the formation phase of the following C. Boundary-related lengthening extends over a continuous interval of speech, and is progressive, decreasing with distance from the boundary.

## 4.0 Discussion

Our data show that the most systematic effect of pre-boundary lengthening in Greek is found on the C and V gestures that immediately precede the boundary. This pattern holds for all possible positions of stress. In stress-final words, the effect is retained within these gestures, while in words with non-final stress the effect is initiated earlier, but which exactly gestures are affected differ across speakers. For instance, for some speakers lengthening extends to the formation of the final C, remaining within the limits of the phrase-final syllable, while for others it extends to the penultimate syllable. These findings point to a dual conclusion about boundary-related lengthening in Greek. First, the effect is mainly limited to phrasal edges, and second, it is attracted towards the stressed syllable.

The first part of this conclusion is reinforced by the very concept of boundary events, the function of which is to mark the edges of phrases (cf. Beckman & Pierrehumbert, 1986; White, 2014). It is also in accordance with previous experimental findings. Articulatory studies have shown that boundary lengthening is confined to boundary-adjacent constrictions (Byrd et al., 2006; Byrd & Riggs, 2008; Krivokapi, 2007a), and acoustic studies have proposed phrase-final syllable, and specifically its rhyme, as the domain of the boundary lengthening effect (Berkovits, 1993a, 1993b, 1994; Cambier-Langeveld, 1997; Campbell & Isard, 1991; Nakatani et al., 1981; Oller, 1973; Wightman et al., 1992).

The second part of this conclusion, meaning that the position of lexical stress is a decisive factor in determining when boundary-related lengthening is initiated, finds empirical parallels from American and British English, in which the stressed syllable of the phrase-final word systematically lengthens as a function of boundary (Turk & Shattuck-Hufnagel, 2007 and White, 2002 respectively). According to these studies, in both American and British English, the domain of boundary-related lengthening includes the stressed syllable. The fact that in Greek boundary-related lengthening expands towards the stressed syllable without necessarily including it might be due to typological differences between Greek and English. Since the data is not sufficient to support this hypothesis, further research on this matter is needed. Evidence for less systematic tendencies of attraction of boundary-related lengthening towards the stress exists elsewhere in the literature and with respect to several languages, like English (Byrd & Riggs, 2008; Nakatani et al., 1981; Oller, 1973), Hebrew (Berkovits, 1994) and Estonian (Krull, 1997). The current findings further contribute to this body of research, by distinguishing lexical stress from pitch accent, and highlighting the importance of lexical stress in determining the initiation of boundary-related lengthening regardless of the presence of a pitch accent or not. Accentuation, although not significantly affecting the scope of boundary-related lengthening, plays a role in the amount of the effect, as shown in Section 3.3.

The effect of phrase-final lexical stress extends to the pause postures following the phrase-final word, with the articulatory movements into these postures being longer in words with final stress as opposed to words with non-final stress. This effect of stress does not extend to the phrase-initial word that follows the pause, with post-boundary lengthening consistently affecting only the initial C gesture. This pattern is not necessarily different from the finding reported in Shattuck-Hufnagel (1998), according to which post-boundary lengthening in American English manifests itself only when the final word of the previous phrase is

prominent (Shattuck-Hufnagel & Turk, 1998). The data from American English did not contain pauses. It is thus still possible that the last lexical stress of a phrase in Greek affects the boundary-related lengthening of the following phrase in cases of weaker boundaries that do not involve pauses. With respect to post-boundary lengthening in Greek, it is constantly and systematically detected on the movement forming the first constriction of the phrase, at least in boundaries involving pauses, agreeing with previous articulatory findings of American English (e.g., Byrd et al., 2006; Byrd & Riggs, 2008; Byrd & Saltzman, 1998; Bombien et al., 2010; Krivokapi, 2007a).

In addition to the scope of pre-boundary lengthening and the duration of pause posture formation, lexical stress in Greek is related to boundary-related shortening. Albeit scarce and small, pre-boundary shortening is manifested by all speakers, indicating that lexical stress and boundaries interact in a complex manner. To our knowledge, boundary-related shortening has been reported in the literature only in relation to post-boundary material, and has been attributed to a compensatory effect, caused by the return of constriction gestures to prosodically unaffected timing (Byrd et al., 2006). The pre-boundary shortening observed in Greek cannot be related to restoring the constrictions' temporal properties that have been perturbed by lengthening. In our view, the pre-boundary shortening effect is a byproduct of a mutual attraction between lexical stress and boundary-related lengthening. Under this scenario, the stress-related lengthening effect in phrase-final words is less than the respective effect phrase-medially, yielding gestures that are shorter in the former case than in the latter. Shortening is also observed post-boundary in our data, manifesting itself in a more systematic way than pre-boundary, regularly affecting the forming gesture of the penultimate syllable's onset consonant. The constant position of this effect is accountable by the compensation hypothesis put forward by Byrd et al. (2006). However, on the basis of the present data (only stress-final words are examined here post-boundary), possible interaction between the domain of post-boundary shortening and the position of phrase-initial lexical stress cannot be excluded.

Our findings also indicate that boundary lengthening extends over a single continuous domain (cf. Byrd & Riggs, 2008; White, 2002; Wightman et al., 1992; but see Turk & Shattuck-Hufnagel, 2007 and its replication by Rusaw 2011, 2013). The manifestation of the effect is such that the amount of lengthening decreases with distance from the boundary (like in e.g., Berkovits, 1993a, b, 1994).

In order to put all these pieces together, we propose the following account of boundary lengthening in Greek within the framework of Articulatory Phonology and the  $\pi$ -gesture model. This account is schematically represented in Figure 9 (the reader is referred to Katsika et al., 2014 for the part of the account that addresses boundary tones).

We propose that in Greek the  $\pi$ -gesture has a dual coordination, being coordinated both with the phrase-final V gesture and with the last stress-related  $\mu$ -gesture of the phrase. The coordination of the  $\pi$ -gesture with the phrase-final V is assumed to be anti-phase, which means that the  $\pi$ -gesture is initiated as the V gesture reaches its articulatory target, explaining the fact that boundary-related lengthening affects the release phase, but not the formation phase, of the last C, and presumably the part of the vowel that overlaps with that C



release. The coordination of the  $\pi$ -gesture with the  $\mu$ -gesture is uncertain on the basis of the current data, and further research is needed to determine this relationship. However, in-phase coordination between these two prosodic gestures is conceptually a more appropriate account of the attraction of the  $\pi$ -gesture towards the  $\mu$ -gesture of the stressed syllable. When stress is final, the phrase-final V and the  $\mu$ - gestures coincide, and as a result the  $\pi$ -gesture, and consequently its lengthening effect as well, is initiated within the phrase-final V. When stress is not final, the  $\mu$ -gesture and the phrase-final V gesture occur in different syllables, and the  $\pi$ -gesture is pulled towards the stressed syllable via its coordination with the  $\mu$ -gesture. The fact that this movement towards the stressed syllable is partial and not complete (the  $\pi$ -gesture moves towards the stressed syllable without necessarily reaching it) implies that the coordination with the  $\mu$ -gesture and the coordination with the phrase-final V gesture are not equal in strength. Rather, the coordination with the  $\mu$ -gesture is weaker than the coordination with the final V gesture. This weak coordination causes a slight shift of the  $\pi$ -gesture towards the  $\mu$ -gesture, initiating boundary lengthening earlier within words with non-final stress as opposed to words with final stress (compare (a) and (b) to (c) in Figure 9). As argued in the previous paragraph, the fact that a shortening effect is observed near or on the stressed syllable suggests that the  $\mu$ -gesture is slightly shifted towards the  $\pi$ -gesture as well. As the  $\pi$ -gesture shifts away from the boundary in words with non-final stress towards the  $\mu$ -gesture, less of the pause posture is co-active with it, and as a result the movement into achieving the pause posture is shorter in phrase-final words with non-final stress than their final-stress counterparts. Thus, the account proposed here, although significantly different from the alternatives proposed in Byrd and Riggs (2008) and illustrated in Figure 3, is similar to the ‘coordination shift’ alternative in that the  $\pi$ -gesture shifts as a whole in reaction to stress position, and rejects the ‘extension’ alternative, in which the  $\pi$ -gesture’s onset extends to the stress while its offset remains stable.

The fact that the position of phrase-final stress exerts an effect on pause postures, but not on the scope of boundary-related lengthening over the following phrase-initial word suggests that phrase-initial lengthening is caused by another  $\pi$ -gesture, which is coordinated with and extends over the first constriction of the phrase. Whether the phrase-initial  $\pi$ -gesture is also coordinated with another gesture, like for example the  $\mu$ -gesture that is related to the lexical stress of the phrase-initial word, cannot be addressed by the current experimental design, and remains an open question for future research. The presence of a second, phrase-initial,  $\pi$ -gesture might not be necessary in all boundaries (cf. Byrd, Lee & Campos-Astorkiza, 2008 for gestural overlap spanning boundaries; see also Byrd & Saltzman, 2003), but seems needed in the following two cases: 1) when no other phrase precedes, as for instance at the very beginning of a discourse, and 2) when a grammatical pause intervenes between the current and the preceding phrase (these pauses are not to be confused with ungrammatical pauses that are related to speech disfluencies). In the case of grammatical pauses, it can be assumed that pause postures are the result of the maximum clock-slowing effect of the  $\pi$ -gesture, which, when reached, slows the articulators so much that they actually stop. The assumption that the articulators stop is based on the very long durations of pauses. However, the position at which the articulators stop does not seem to be random or context-dependent, but targeted (cf. Ramanarayanan et al., 2013), possibly reflecting a default articulatory setting (cf. Gick et al., 2004). That the articulatory configuration related to pauses observed

in our data is targeted, and thus planned, is also supported by our recent finding that pause postures are achieved at a fixed time from the onset of boundary tones (Katsika et al., 2014). This relationship between boundary tones and pause postures in combination with the widely accepted observation that boundary tones occur at strong boundaries while grammatical pauses occur in a subset of these strong boundaries was taken as an indication that prosodic events are a function of  $\pi$ -gesture's level of activation (Katsika et al., 2014). Boundary tones are activated when  $\pi$ -gestures reach a specific high level of activation, and pause postures are activated when  $\pi$ -gestures reach another specific, even higher, level of activation (see Figure 9). This proposal is congruous with the notion that lengthening increases cumulatively (e.g., pre-boundary: Byrd, 2000, Byrd & Saltzman, 1998, Cho, 2006, Tabain, 2003b, Tabain & Perrier, 2005), but its scope remains stable across the levels of prosodic hierarchy (Cambier-Langeveld, 1997). It further extends this notion to capture boundary tones and pauses in a unifying manner, since both these types of prosodic events are dependent on whether the  $\pi$ -gesture reaches the appropriate levels, which are in turn related to specific amounts of lengthening. If the assumption that, when achieving these pause postures, the articulators stop is valid, a second, phrase-initial  $\pi$ -gesture would be needed to reinitiate articulatory movement. Everything else being equal, the phrase-final and phrase-initial  $\pi$ -gestures might overlap depending on the length of their temporal intervals. The proposal for two  $\pi$ -gestures being active at pause-containing boundaries fits well with Ferreira's suggestion that pauses consist of two parts, one related to the phrase preceding the pause and the other related to the phrase following the pause (e.g., Ferreira, 1991).

This proposal, in addition to capturing the facts of Greek, puts forward a novel account that views prosodic boundaries in an integrated fashion, since the boundary prosodic events (i.e., boundary-related lengthening, boundary tones and pauses) emerge from a single system, and allows typological extensions (outlined below). This view has two main tenets. First, boundary prosodic events (i.e., boundary-related lengthening, boundary tones and pauses) are interdependent, and second, lexical prosody does not only interact with phrasal prosody, but functions as the interface between the latter and constriction gestures. The interdependency between boundary events, by addressing their very nature, is expected to hold cross-linguistically. Given the current little knowledge on the prosodic hierarchy of most languages and on the articulatory profile of pauses, this hypothesis still awaits validation. Future research will need to examine whether phrase-final lengthening is a universal phenomenon, whether boundary tones presuppose the presence of lengthening in order to mark typical boundaries, whether, in turn, grammatical, planned, pauses presuppose the presence of boundary tones, and what the timing relationship among lengthening, boundary tones and pauses is. Future research will also need to investigate and integrate into the account prosodic boundaries that have less common communicative functions, such as careful deliberation and attentional focus, in which boundary-related lengthening has been found to occur in the absence of boundary tones and vice versa, and which have been described for that reason as containing mismatches between the two types of events (Beckman & Elam, 1997).

As for the notion of the interface, the hypothesis that lexical prosody (e.g., stress) functions as the interface between phrasal prosody and constriction gestures is compelling and could offer an account for both boundaries and prominence. It is already well accepted that in

prominence accentuation-related lengthening and the accompanying pitch accents are associated with stressed syllables. We could similarly assume that at boundaries, the stress-related  $\mu$ -gesture, whose coordination with the constriction gestures comprising the lexical item is by definition fixed in the lexicon, functions as the 'go' signal for the phrase-final  $\pi$ -gesture, which by being phrasal does not have a fixed coordination within lexical items. Assuming that lexical prosody interfaces between the boundary events and articulation at least phrase-finally makes conceptual sense, since both the stress-related  $\mu$ -gesture and the  $\pi$ -gesture are clock-slowness gestures that phrase-finally need to occur one after the other. Without the 'go' signal from lexical prosody, the cognitive system would have needed 'to look ahead' and detect the last lexical event in advance in order to coordinate the  $\pi$ -gesture with it. In parallel, the assumption that phrase-initial  $\pi$ -gestures are coordinated only with the first constriction gesture of the phrase is also conceptually reasonable. It seems plausible for our cognitive system to be able 'to know' to initiate a non-lexical event, such as a phrase-initial  $\pi$ -gesture, coupled with a lexical event that comes first in a list of other lexical events. This account, however speculative in nature, sets a basis for formalizing hypotheses and for investigating and revealing typological dimensions. For example, in different languages the  $\pi$ -gesture might have a stronger coordination with the  $\mu$ -gesture than with the final V gesture or the coordination with the final V gesture might be completely lacking. This could explain patterns like the ones observed in American (e.g., Turk & Shattuck-Hufnagel, 2007) or British English (White, 2002), in which boundary-related lengthening consistently affects the stressed syllables regardless of its distance from the boundary. Alternatively, other languages might have the  $\pi$ -gesture coordinated just with a constriction gesture, such as the first constriction gesture of the phrase-final word, which could capture the pre-boundary lengthening patterns reported for German (Kohler, 1983; Silverman, 1990). It needs to be noted though that the patterns in German might still be related to lexical stress, since in German lexical stress is mainly positioned on the first syllable of each morpheme. The possibility of the  $\pi$ -gesture being coordinated solely with the phrase-final V is not excluded either, but due to the look-ahead problem mentioned above, it is not the most preferred option. It is thus expected to be encountered the least across the world's languages and to present the shortest scope of the effect. If the hypothesis that lexical prosody serves as the interface, or is the most preferred interface, between phrasal prosody and the constriction gestures of lexical items is valid, this should hold across languages with different lexical prosodies. A representative list would include, in addition to languages with lexical stress, languages that employ lexical tones (e.g., Chinese), lexical pitch accent (e.g., Japanese), both lexical tone and lexical stress (e.g., Ma'ta), both lexical stress and lexical pitch accent (e.g., Serbo-Croatian), and accentual phrases (e.g., French) (for the lexical prosody of these languages see Fletcher, 2010 and references within).

The current study and its complementary part (Katsika et al., 2014) revealed significant effects of lexical stress on boundary-related phrasal events and proposed an account of prosodic boundaries in Greek with promising cross-linguistic extensions, highlighting the importance of kinematic data and speaker-specific investigation in detecting fine-tuned effects.

## Acknowledgments

This work was supported by NIH grant NIDCD DC 008780 to Louis Goldstein, and NIH grant NIDCD DC 002717 to Douglas Whalen. The author is grateful to Jelena Krivokapi, Louis Goldstein, Christine Mooshammer and Mark Tiede for their support and assistance. Special thanks go to Amalia Arvaniti, Hosung Nam, Elliot Saltzman, Stefanie Shattuck-Hufnagel, and Douglas Whalen for their useful feedback.

## Reference list

- Arvaniti A. Greek phonetics: The state of the Art. *Journal of Greek Linguistics*. 2007; 8:97–208.
- Arvaniti, A.; Baltazani, M. Intonational analysis and prosodic annotation of Greek spoken corpora. In: Jun, S-A., editor. *Prosodic Typology: The Phonology of Intonation and Phrasing*. Oxford, U.K: Oxford University Press; 2005. p. 84-117.
- Arvaniti A, Ladd DR, Mennen I. Tonal association and tonal alignment: evidence from Greek polar questions and contrastive statements. *Language and Speech*. 2006b; 49:421–450. [PubMed: 17326587]
- Beckman, ME.; Edwards, J. *Speech Perception, Production and Linguistics Structure*. Tokyo, Japan: Ohmsha; 1992. Intonational categories and the articulatory control of duration; p. 359-375.
- Beckman, ME.; Elam, GA. Guidelines for ToBI labelling. Manuscript and accompanying speech materials. 1997. available from [ling.ohio-state.edu/tobi](http://ling.ohio-state.edu/tobi)
- Beckman ME, Pierrehumbert JB. Intonational structure in Japanese and English. *Phonology Yearbook*. 1986; 3:255–309.
- Berkovits R. Progressive utterance-final lengthening in syllables with final fricatives. *Language and Speech*. 1993a; 36:89–98. [PubMed: 8345773]
- Berkovits R. Utterance-final lengthening and the duration of final-stop closures. *Journal of Phonetics*. 1993b; 21:476–489.
- Berkovits R. Durational effects in final lengthening, gapping, and contrastive stress. *Language and Speech*. 1994; 37:237–250. [PubMed: 7861912]
- Bombien L, Mooshammer C, Hoole P, Kuehnert B. Prosodic and segmental effects on EPG contact patterns of word-initial German clusters. *Journal of Phonetics*. 2010; 38:388–403.
- Browman CP, Goldstein LM. Articulatory Phonology: An overview. *Phonetica*. 1992; 45:155–180.
- Byrd D. Articulatory vowel lengthening and coordination at phrasal junctures. *Phonetica*. 2000; 57:3–16. [PubMed: 10867568]
- Byrd, D.; Choi, S. *Papers in Laboratory Phonology X*. Berlin, Germany: Mouton de Gruyter; 2006. At the Juncture of prosody, phonology, and phonetics - The interaction of phrasal and syllable structure in shaping the timing of consonant gestures; p. 31-60.
- Byrd, D.; Kaun, A.; Narayanan, S.; Saltzman, E. Phrasal signatures in articulation. In: Kingston, J.; Beckman, ME., editors. *Papers in Laboratory Phonology V: Acquisition and the Lexicon*. Cambridge, U.K: Cambridge University Press; 2000. p. 70-87.
- Byrd D, Krivokapi J, Lee S. How far, how long: On the temporal scope of phrase boundary effects. *Journal of the Acoustical Society of America*. 2006; 123:4456–4465.
- Byrd D, Lee S, Campos-Astorkiza R. Phrase-boundary effects on the temporal kinematics of sequential tongue tip consonants. *Journal of the Acoustical Society of America*. 2008; 120:1589–1599.
- Byrd D, Riggs D. Locality interactions with prominence in determining the scope of phrasal lengthening. *Journal of the International Phonetic Association*. 2008; 38:187–202. [PubMed: 19888443]
- Byrd D, Saltzman E. Intra-gestural dynamics of multiple phrasal boundaries. *Journal of Phonetics*. 1998; 26:173–199.
- Byrd D, Saltzman E. The elastic phrase: Modeling the dynamics of boundary-adjacent lengthening. *Journal of Phonetics*. 2003; 31:149–180.
- Cambier-Langeveld, T. The domain of final lengthening in the production of Dutch. In: Coerts, J.; de Hoop, H., editors. *Linguistics in the Netherlands*. Amsterdam, Netherlands: John Benjamins; 1997. p. 13-24.

- Campbell WN, Isard SD. Segment durations in a syllable frame. *Journal of Phonetics*. 1991; 19:37–47.
- Cho T. Prosodically conditioned strengthening and vowel-to-vowel coarticulation in English. *Journal of Phonetics*. 2004; 32:141–176.
- Cho, T. *Papers in Laboratory Phonology VIII: Varieties of Phonological Competence (Phonology and Phonetics)*. Berlin, Germany: Mouton de Gruyter; 2006. Manifestation of prosodic structure in articulatory variation: Evidence from lip kinematics in English; p. 519-548.
- Cho T. Prosodic strengthening in transboundary V-to-V lingual movement in American English. *Phonetica*. 2008; 65:45–61. [PubMed: 18523366]
- Cho T, Keating P. Articulatory and acoustic studies on domain-initial strengthening in Korean. *Journal of Phonetics*. 2001; 29:155–190.
- Cho T, Keating P. Effects of initial position versus prominence in English. *Journal of Phonetics*. 2009; 37:466–485.
- Cho T, McQueen J, Cox E. Prosodically driven phonetic detail in speech processing: The case of domain-initial strengthening in English. *Journal of Phonetics*. 2007; 35:210–243.
- Cooper, WE.; Paccia-Cooper, J. *Syntax and Speech*. Cambridge, MA: Harvard University Press; 1980.
- Dimitrova S, Turk A. Patterns of accentual lengthening in English four-syllable words. *Journal of Phonetics*. 2012; 40:403–418.
- Edwards J, Beckman ME, Fletcher J. The articulatory kinematics of final lengthening. *Journal of the Acoustical Society of America*. 1991; 89:369–382. [PubMed: 2002175]
- Ferreira F. Effects of length and syntactic complexity on initiation times for prepared utterances. *Journal of Memory and Language*. 1991; 30:210–233.
- Fletcher, J. *The Prosody of Speech: Timing and Rhythm*. In: Hardcastle, WJ.; Laver, J.; Gibbon, FE., editors. *The Handbook of Phonetic Sciences*. Hoboken, NJ: Wiley-Blackwell; 2010. p. 523-602.
- Fougeron C. Articulatory properties of initial segments in several prosodic constituents in French. *Journal of Phonetics*. 2001; 29:109–135.
- Fougeron C, Jun S. Rate effects on French intonation: prosodic organization and phonetic realization. *Journal of Phonetics*. 1998; 26:45–69.
- Fougeron C, Keating P. Articulatory strengthening at edges of prosodic domains. *Journal of the Acoustical Society of America*. 1997; 101:3728–3740. [PubMed: 9193060]
- Fuchs S, Petrone C, Krivokapi J, Hoole P. Acoustic and respiratory evidence for utterance planning in German. *Journal of Phonetics*. 2013; 41:29–47.
- Gao, M. PhD thesis. Yale University; 2008. *Mandarin Tones: an Articulatory Phonology Account*.
- Gick B, Wilson I, Kock K, Cook C. Language-specific articulatory settings: Evidence from inter-utterance rest position. *Phonetica*. 2004; 61:220–233. [PubMed: 15824488]
- Goldstein, LM.; Byrd, D.; Saltzman, E. The role of vocal tract gestural action units in understanding the evolution of phonology. In: Arbib, M., editor. *From action to language: The mirror neuron system*. Cambridge, U.K: Cambridge University Press; 2006. p. 215-249.
- Hayes, B. The prosodic hierarchy in meter. In: Kiparsky, P.; Youmans, G., editors. *Phonetics and Phonology, Vol. 1: rhythm and meter*. New York, N.Y: Academic Press, Inc; 1989. p. 201-259.
- Hirose, H. Investigating the Physiology of Laryngeal Structures. In: Hardcastle, WJ.; Laver, J.; Gibbon, FE., editors. *The Handbook of Phonetic Sciences*. Hoboken, NJ: Wiley-Blackwell; 2010. p. 130-152.
- Hoole, P.; Zierdt, A.; Geng, C. Beyond 2D in articulatory data acquisition and analysis; *Proceedings of The 15th International Congress of Phonetic Sciences*; 2003. p. 265-268.
- Kainada Evia, . Prosodic Boundary Effects on Durations and Vowel Hiatus in Modern Greek; *Proceedings of the 16th International Congress of Phonetic Sciences*; Saarbrücken: Uneversität des Saarlandes; 2007. p. 1225-1228.
- Katsika A. Boundary- and prominence-related lengthening and their interaction. *Journal of the Acoustical Society of America*. 2009; 125:2572–2572.
- Katsika A, Krivokapi J, Mooshammer C, Tiede M, Goldstein L. The coordination of boundary tones and their interaction with prominence. *Journal of Phonetics*. 2014; 44:62–82. [PubMed: 25300341]

- Keating, P.; Cho, T.; Fourgeron, C.; Hsu, C. *Papers in Laboratory Phonology VI: Phonetic Interpretation*. Cambridge, U.K: Cambridge University Press; 2004. Domain-initial articulatory strengthening in four languages; p. 143-161.
- Keating P, Wright R, Zhang J. World-level asymmetries in consonant articulation. *UCLA Working Papers in Phonetics*. 1999; 97:157–173.
- Klatt DH. Vowel lengthening is syntactically determined in a connected discourse. *Journal of Phonetics*. 1975; 3:129–140.
- Kohler K. Prosodic boundary signals in German. *Phonetica*. 1983; 40:89–134.
- Krivokapi J. PhD thesis. University of Southern California; 2007a. The planning, production and perception of prosodic structure.
- Krivokapi J. Prosodic planning: effects of phrasal length and complexity on pause duration. *Journal of Phonetics*. 2007b; 35:162–179. [PubMed: 18379639]
- Krivokapi J. Gestural Coordination at prosodic boundaries and its role for prosodic structure and speech planning processes. *Philosophical Transactions of the Royal Society B*. 2014; 369:20130397. <http://dx.doi.org/10.1098/rstb.2013.0397>.
- Krivokapi J, Byrd D. Prosodic boundary strength: an articulatory and perceptual study. *Journal of Phonetics*. 2012; 40:430–442. [PubMed: 23441103]
- Krull, D. Prepausal lengthening in Estonian: Evidence from conversational speech. In: Lehiste, I.; Ross, J., editors. *Estonian Prosody: Papers from a Symposium*. Institute of Estonian Language and Authors; 1997.
- Lehiste I. Rhythmic units and syntactic units in production and perception. *Journal of the Acoustical Society of America*. 1973; 54:1228–1234. [PubMed: 4765807]
- McGowan RS, Saltzman EL. Incorporating aerodynamic and laryngeal components into task dynamics. *Journal of Phonetics*. 1995; 23:255–269.
- Mücke, D.; Nam, H.; Hermes, A.; Goldstein, LM. Coupling of tone and constriction gestures in pitch accents. In: Hoole, P.; Bombien, L.; Pouplier, M.; Mooshammer, C.; Kühnert, B., editors. *Consonant Clusters and Structural Complexity*. Berlin: Mouton de Gruyter; 2012. p. 205-230.
- Nakatani LH, O'Connor KD, Aston CH. Prosodic aspects of American English speech rhythm. *Phonetica*. 1981; 38:84–106.
- Nespor, M.; Vogel, I. *Prosodic phonology*. Dordrecht: Foris; 1986.
- Oller KD. The effect of position in utterance on speech segment duration in English. *Journal of the Acoustic Society of America*. 1973; 54:1235–1247.
- Pierrehumbert, JB. PhD thesis. M.I.T; 1980. The phonology and phonetics of English intonation.
- Riggs D, Byrd D. The scope of phrasal lengthening: Articulatory and acoustic evidence. *Journal of the Acoustical Society of America*. 2011; 130:2549–2549.
- Ramanarayanan, V.; Byrd, D.; Goldstein, L.; Narayanan, S. *Proceedings of Interspeech 2010*. Makuhari, Japan: 2010 Sep. Investigating articulatory setting – pauses, ready position and rest – using real-time MRI.
- Ramanarayanan V, Bresch E, Byrd D, Goldstein L, Narayanan S. Analysis of pausing in spontaneous speech using real-time magnetic resonance imaging of articulation. *Journal of the Acoustical Society of America, Express Letters*. 2009; 126:EL160–EL165.
- Ramanarayanan V, Goldstein L, Byrd D, Narayanan S. A real-time MRI investigation of articulatory setting across different speaking styles. *Journal of the Acoustical Society of America*. 2013; 134:510–519. [PubMed: 23862826]
- Rusaw EC. A biologically inspired neural network for modeling phrase-final lengthening. *Journal of the Acoustical Society of America*. 2011; 130:2553–2553.
- Rusaw, EC. PhD thesis. University of Illinois at Urbana-Champaign; 2013. Modeling temporal coordination in speech production using an artificial central pattern generator neural network.
- Saltzman, E. Task dynamic co-ordination of the speech articulators: a preliminary model. In: Heuer, H.; Fromm, C., editors. *Generation and Modulation of Action Patterns*. Berlin, Germany: Springer-Verlag; 1986. p. 129-144.
- Saltzman E, Munhall KG. A dynamical approach to gestural patterning in speech production. *Ecological Psychology*. 1989; 1:333–382.



- Saltzman, E.; Nam, H.; Krivokapi, J.; Goldstein, L. A task-dynamic toolkit for modeling the effects of prosodic structure on articulation; Proceedings of the Speech Prosody 2008 Conference pages; 2008. p. 175-184.
- Selkirk, E. Phonology and Syntax: The Relation Between Sound and Structure. Cambridge, MA: M.I.T. Press; 1984.
- Selkirk, E. The prosodic structure of function words. In: Morgan, J.L.; Demuth, K., editors. Signal to Syntax: Bootstrapping from Speech to Grammar in Early Acquisition. Mahwah, NJ: Lawrence Erlbaum Associates; 1996. p. 187-214.
- Shattuck-Hufnagel S, Turk A. The domain of phrase-final lengthening in English. Journal of the Acoustical Society of America. 1998; 103:2889–2889.
- Silverman, K. The separation of prosodies: comments on Kohler's paper. In: Kingston, J.; Beckman, M.E., editors. Papers in Laboratory Phonology I: Between the Grammar and Physics of Speech. Cambridge, U.K.: Cambridge University Press; 1990. p. 139-151.
- Silverman, K.; Beckman, M.E.; Pitrelli, J.; Ostendorf, M.; Wightman, C.; Price, P.; Pierrehumbert, J.; Hirschberg, J. ToBI: a standard labeling English prosody; Proceedings of the International Conference of Spoken Language Processing; 1992. p. 867-870.
- Tabain M. Effects of prosodic boundary on /aC/ sequences: acoustic results. Journal of the Acoustical Society of America. 2003a; 113:516–531. [PubMed: 12558288]
- Tabain M. Effects of prosodic boundary on /aC/ sequences: articulatory results. Journal of the Acoustical Society of America. 2003b; 113:2834–2849. [PubMed: 12765400]
- Tabain M, Perrier P. Articulation and acoustics of /i/ at prosodic boundaries in French. Journal of Phonetics. 2005; 33:77–100.
- Turk, A.E. Structural influences on boundary-related lengthening in English; Proceedings of the 14th International Congress of Phonetic Sciences; 1999. p. 237-240.
- Turk A.E., Shattuck-Hufnagel S. Multiple targets of phrase-final lengthening in American English words. Journal of Phonetics. 2007; 35:445–472.
- Umeda N. Vowel duration in American English. Journal of the Acoustical Society of America. 1975; 58:434–445. [PubMed: 1184837]
- White, L. PhD thesis. The University of Edinburgh; 2002. English Speech Timing: A domain and locus approach.
- Wightman C.W., Shattuck-Hufnagel S, Ostendorf M, Price P.J. Segmental durations in the vicinity of prosodic phrase boundaries. Journal of the Acoustical Society of America. 1992; 91:1707–1717. [PubMed: 1564206]
- Wheeldon L, Lahiri A. Prosodic units in speech production. Journal of Memory and Language. 1997; 37:356–381.
- White L. Communicative function of prosodic form in speech timing. Speech communication. 2014; 63:38–54.

## Appendix A

The planned t-test comparisons of the durations (in ms; with SD within parentheses underneath the respective durations) of the constriction gestures of the accented IP<sub>1</sub>-final words (a: C1-V3) and their subsequent IP<sub>2</sub>-initial words (b: C4-C6) across BOUNDARIES (IP vs. W) per STRESS (S1, S2, S3) for each

**Tables A1a-A8b**

speaker (F01, F02, F03, F04 and M05) and construction (ADYNQCPCP). Dark gray and light gray cells represent significantly longer (>) and shorter (<) IP than W respectively (p < 0.05)). White cells represent insignificant comparisons. Key: C = consonant, V = vowel, F = formation, R = release.

a (AD)	C1-/m/		V1-/e/	C2-/m/		V2-/l/	C3-/m/		V3-/a/	
	F	R		F	R		F	R		
S1 (stress-initial)	F01	96 < 106 (7, 8)	43 = 42 (4, 5)	127 = 138 (15, 16)	79 < 85 (6, 7)	36 = 41 (4, 8)	143 = 140 (5, 7)	74 = 72 (7, 14)	62 > 45 (9, 12)	168 = 157 (14, 22)
	F02	109 = 132 (29, 27)	73 = 79 (15, 14)	164 < 197 (33, 28)	80 = 90 (9, 13)	41 = 41 (9, 18)	157 = 149 (16, 24)	93 > 70 (11, 16)	89 > 62 (12, 16)	156 > 109 (27, 23)
	F03	114 < 124 (7, 7)	81 = 78 (6, 12)	202 = 212 (13, 18)	105 = 95 (9, 16)	54 = 53 (10, 16)	187 = 169 (12, 24)	89 > 69 (5, 15)	74 > 44 (10, 13)	146 > 120 (17, 15)
	F04	123 = 122 (16, 10)	64 = 69 (4, 6)	182 = 181 (10, 19)	97 = 97 (6, 6)	41 = 36 (4, 6)	175 > 165 (12, 8)	86 > 66 (12, 7)	97 > 47 (40, 8)	167 > 112 (30, 14)
	M05	78 = 86 (6, 13)	58 < 69 (6, 13)	154 < 186 (11, 20)	74 = 77 (7, 8)	56 = 56 (9, 11)	138 > 131 (9, 8)	55 = 58 (6, 11)	97 = 86 (19, 20)	168 = 176 (14, 19)
S2 (stress-medial)	F01	84 = 81 (6, 5)	38 < 42 (4, 3)	112 < 128 (7, 12)	84 < 97 (7, 7)	47 < 53 (4, 8)	171 = 174 (19, 13)	93 < 103 (7, 10)	81 > 52 (8, 11)	181 = 159 (18, 33)
	F02	78 = 83 (19, 5)	59 < 66 (6, 2)	159 = 177 (27, 25)	103 = 111 (16, 15)	66 = 59 (16, 10)	186 = 170 (30, 51)	93 > 84 (8, 9)	82 > 45 (16, 16)	143 > 118 (23, 16)
	F03	92 = 92 (9, 4)	47 = 46 (8, 3)	137 < 159 (5, 26)	106 = 115 (11, 13)	61 = 54 (9, 10)	217 > 193 (11, 11)	124 > 89 (5, 12)	88 > 50 (11, 7)	183 > 150 (11, 29)
	F04	104 = 105 (6, 10)	46 = 46 (4, 4)	123 < 135 (8, 8)	102 = 100 (14, 9)	59 = 58 (7, 4)	223 = 207 (24, 24)	111 > 89 (5, 9)	90 > 51 (8, 14)	162 = 143 (18, 32)
	M05	67 = 67 (8, 18)	51 = 52 (10, 8)	141 = 149 (21, 15)	71 = 75 (6, 10)	52 < 74 (9, 7)	153 = 164 (11, 14)	82 = 83 (8, 8)	81 = 75 (9, 17)	181 = 193 (18, 13)
S3 (stress-final)	F01	77 = 78 (6, 7)	39 = 35 (2, 3)	93 = 98 (10, 9)	63 < 69 (6, 8)	38 = 37 (6, 4)	128 < 140 (8, 7)	74 < 88 (5, 6)	77 = 72 (12, 19)	188 = 174 (9, 25)
	F02	76 = 77 (15, 14)	49 = 54 (7, 9)	109 = 120 (11, 21)	54 < 69 (12, 18)	35 = 45 (14, 15)	166 = 170 (17, 21)	134 = 115 (21, 29)	84 > 69 (10, 12)	182 = 186 (18, 36)
	F03	77 = 79 (13, 7)	42 = 46 (7, 6)	113 < 132 (8, 21)	74 = 79 (14, 8)	50 = 51 (9, 8)	159 = 164 (14, 21)	110 = 107 (10, 8)	80 > 60 (4, 8)	189 > 158 (8, 18)
	F04	105 = 111 (12, 17)	38 = 41 (4, 5)	114 = 126 (11, 19)	71 = 73 (6, 7)	40 = 40 (4, 7)	164 = 167 (9, 8)	98 = 100 (8, 15)	100 > 65 (7, 7)	187 > 153 (16, 23)
	M05	63 = 68 (5, 10)	43 < 51 (6, 8)	109 < 126 (9, 14)	64 = 62 (7, 8)	35 < 45 (10, 8)	136 = 141 (17, 12)	77 = 76 (10, 12)	86 < 102 (11, 17)	187 < 201 (9, 14)

b (AD)	C4-/m/		C5-/l/		C6-/ks/		
	F	R	F	R	F	R	
S1 (stress-initial)	F01	111 > 70 (32, 6)	104 > 76 (30, 22)	72 < 89 (12, 10)	54 > 38 (9, 9)	89 > 78 (6, 6)	66 = 68 (11, 7)
	F02	144 > 72 (41, 11)	93 = 94 (20, 26)	99 = 126 (33, 47)	76 = 57 (20, 17)	83 = 86 (13, 12)	56 = 59 (17, 18)
	F03	146 > 90 (27, 18)	72 = 86 (25, 32)	107 = 115 (18, 25)	57 = 54 (9, 7)	192 < 212 (47, 36)	107 > 82 (45, 33)
	F04	118 > 64 (16, 17)	72 = 70 (19, 30)	92 = 105 (9, 21)	63 = 59 (13, 6)	181 = 179 (36, 33)	105 < 113 (48, 31)
	M05	66 > 56 (12, 9)	66 = 63 (9, 7)	62 < 80 (7, 17)	64 = 59 (7, 8)	93 = 96 (7, 8)	46 = 40 (6, 7)
S2 (stress-medial)	F01	104 > 79 (21, 12)	96 = 74 (37, 16)	73 = 85 (13, 16)	53 = 53 (10, 16)	89 > 80 (9, 11)	65 = 66 (12, 10)
	F02	123 > 81 (39, 24)	100 = 116 (40, 30)	88 = 108 (29, 25)	70 = 64 (15, 14)	82 < 93 (26, 13)	67 = 60 (31, 17)
	F03	150 > 91 (48, 28)	91 = 80 (28, 30)	102 < 129 (14, 19)	49 = 50 (14, 8)	201 = 175 (53, 60)	94 = 106 (43, 43)
	F04	119 > 71 (21, 30)	73 = 78 (20, 33)	104 = 117 (23, 22)	57 = 59 (4, 5)	183 = 185 (35, 45)	82 = 87 (23, 38)
	M05	61 = 62 (7, 15)	67 > 56 (7, 6)	70 = 70 (12, 13)	49 < 58 (8, 8)	97 = 95 (7, 4)	45 = 41 (9, 6)
S3 (stress-final)	F01	116 > 93 (24, 13)	110 > 82 (22, 24)	72 < 93 (9, 12)	54 > 45 (7, 10)	88 = 84 (13, 10)	69 = 65 (10, 6)
	F02	158 > 89 (47, 15)	103 > 70 (23, 7)	110 = 94 (32, 8)	59 = 71 (28, 16)	81 = 84 (22, 12)	74 = 65 (36, 17)
	F03	144 > 113 (25, 34)	72 = 79 (27, 26)	105 < 152 (29, 54)	58 = 52 (6, 11)	169 = 179 (53, 49)	105 = 81 (37, 32)
	F04	112 > 77 (17, 8)	70 < 97 (17, 36)	98 < 129 (9, 38)	59 = 57 (5, 6)	175 = 181 (42, 39)	85 = 116 (33, 36)
	M05	78 = 62 (18, 13)	82 = 66 (28, 5)	73 = 74 (16, 14)	55 = 59 (11, 10)	94 = 95 (5, 6)	42 = 43 (7, 9)



a (Y/NQ)	C1-/m/		V1-/v/	C2-/m/		V2-/l/	C3-/m/		V3-/a/	
	F	R		F	R		F	R		
S1 (stress-initial)	F01	92 < 106 (8, 8)	49 > 42 (3, 5)	148 = 138 (11, 16)	79 < 85 (6, 7)	41 = 41 (6, 8)	135 = 140 (7, 7)	71 = 72 (6, 14)	84 > 45 (6, 12)	182 > 157 (32, 22)
	F02	115 = 132 (18, 27)	71 = 79 (10, 14)	183 = 197 (21, 28)	88 = 90 (6, 13)	39 = 41 (10, 18)	153 = 149 (13, 24)	91 > 70 (10, 16)	93 > 62 (6, 16)	183 > 109 (27, 23)
	F03	109 < 124 (5, 7)	73 = 78 (5, 12)	194 < 212 (10, 18)	98 = 95 (5, 16)	50 = 53 (8, 16)	170 = 169 (8, 24)	98 > 69 (13, 15)	84 > 44 (10, 13)	171 > 120 (13, 15)
	F04	118 = 122 (10, 10)	72 = 69 (5, 6)	187 = 181 (13, 19)	98 = 97 (8, 6)	43 > 36 (6, 6)	178 > 165 (8, 8)	85 > 66 (8, 7)	98 > 47 (5, 8)	196 > 112 (45, 14)
	M05	82 = 86 (16, 13)	71 = 69 (5, 13)	176 = 186 (8, 30)	67 < 77 (6, 8)	48 = 56 (8, 11)	126 = 131 (9, 8)	62 = 58 (13, 11)	107 > 86 (10, 20)	186 = 176 (28, 19)
S2 (stress-medial)	F01	78 = 81 (6, 5)	40 = 42 (5, 3)	109 < 128 (6, 12)	84 < 97 (5, 7)	42 < 53 (5, 8)	163 = 174 (12, 13)	84 < 103 (6, 10)	98 > 52 (9, 11)	199 > 159 (30, 33)
	F02	79 = 83 (11, 5)	67 = 66 (3, 2)	142 < 177 (20, 35)	101 = 111 (8, 15)	67 > 59 (5, 10)	171 = 170 (57, 51)	92 = 84 (10, 9)	94 > 45 (6, 16)	193 > 118 (66, 16)
	F03	93 = 92 (5, 4)	42 < 46 (4, 3)	139 < 159 (16, 26)	105 = 115 (10, 13)	53 = 54 (7, 10)	196 = 193 (12, 11)	116 > 89 (6, 12)	84 > 50 (10, 7)	190 > 150 (17, 29)
	F04	108 = 105 (9, 10)	44 = 46 (4, 4)	124 < 135 (17, 8)	104 = 100 (11, 9)	64 > 58 (5, 4)	236 = 207 (26, 24)	110 > 89 (10, 9)	102 > 51 (6, 14)	214 > 143 (38, 32)
	M05	62 = 67 (10, 18)	45 < 52 (8, 8)	141 = 149 (11, 15)	63 = 75 (7, 10)	67 = 74 (10, 7)	154 = 164 (10, 14)	84 = 83 (4, 8)	92 > 75 (15, 17)	207 = 193 (26, 13)
S3 (stress-final)	F01	66 < 78 (3, 7)	40 > 35 (3, 3)	94 = 98 (7, 9)	68 = 69 (6, 8)	32 < 37 (9, 4)	131 < 140 (7, 7)	86 = 88 (15, 6)	87 > 72 (5, 19)	251 > 174 (58, 25)
	F02	83 = 77 (18, 14)	52 = 54 (8, 9)	103 < 120 (18, 21)	69 = 69 (6, 18)	41 = 45 (24, 15)	161 = 170 (12, 21)	117 = 115 (23, 29)	98 > 69 (16, 12)	204 = 186 (39, 36)
	F03	78 = 79 (5, 7)	41 = 46 (7, 6)	108 = 132 (10, 21)	70 = 79 (7, 8)	48 = 51 (4, 8)	152 = 164 (8, 21)	107 = 107 (9, 8)	83 > 60 (6, 8)	193 > 158 (13, 18)
	F04	105 = 111 (7, 7)	37 < 41 (5, 5)	115 = 126 (13, 19)	67 < 73 (6, 7)	41 = 40 (6, 7)	167 = 167 (12, 8)	103 = 100 (8, 15)	106 > 65 (13, 7)	190 > 153 (38, 23)
	M05	64 = 68 (8, 10)	46 = 51 (7, 8)	112 < 126 (8, 14)	56 = 62 (6, 8)	47 = 45 (9, 8)	133 = 141 (22, 12)	72 = 76 (9, 12)	99 = 102 (11, 17)	227 = 201 (45, 14)

b (YNQ)	C4-/m/		C5-/t/		C6-/ks/		
	F	R	F	R	F	R	
S1 (stress-initial)	F01	103 > 70 (16, 6)	103 = 76 (36, 22)	87 < 89 (9, 10)	50 > 38 (12, 9)	83 = 78 (5, 6)	71 = 68 (9, 7)
	F02	98 > 72 (31, 11)	117 = 94 (29, 26)	76 < 126 (26, 47)	60 = 57 (31, 17)	78 = 86 (16, 12)	70 = 59 (20, 18)
	F03	157 > 90 (38, 18)	85 = 86 (30, 32)	94 < 115 (11, 25)	57 = 54 (8, 7)	156 < 212 (51, 36)	131 > 82 (43, 33)
	F04	112 > 64 (18, 17)	86 = 70 (39, 30)	103 = 105 (17, 21)	57 = 59 (4, 6)	161 = 179 (37, 33)	124 = 113 (44, 31)
	M05	67 = 56 (16, 9)	93 > 63 (36, 7)	68 = 80 (12, 17)	66 = 59 (19, 8)	97 = 96 (6, 8)	46 > 40 (8, 7)
S2 (stress-medial)	F01	113 > 79 (25, 12)	91 = 74 (35, 16)	73 = 85 (9, 16)	59 = 53 (11, 16)	92 > 80 (10, 11)	66 = 66 (6, 10)
	F02	135 > 81 (38, 24)	98 = 116 (35, 30)	72 < 108 (19, 25)	54 = 64 (21, 14)	83 = 93 (21, 13)	90 > 60 (32, 17)
	F03	146 > 91 (19, 28)	94 = 80 (29, 30)	98 < 129 (12, 19)	56 = 50 (10, 8)	179 = 175 (54, 60)	110 = 106 (44, 43)
	F04	123 > 71 (27, 30)	79 = 78 (21, 33)	106 = 117 (20, 22)	58 = 59 (9, 5)	160 = 185 (39, 45)	90 = 87 (44, 38)
	M05	68 = 62 (8, 15)	76 > 56 (28, 6)	71 = 70 (9, 13)	57 = 58 (14, 8)	100 > 95 (6, 4)	42 = 41 (9, 6)
S3 (stress-final)	F01	123 > 93 (27, 13)	93 = 82 (35, 24)	71 < 93 (14, 12)	57 > 45 (6, 10)	92 = 84 (8, 10)	72 = 65 (8, 6)
	F02	122 > 89 (39, 15)	98 > 70 (25, 7)	98 = 94 (29, 8)	53 = 71 (22, 16)	93 = 84 (19, 12)	61 = 65 (17, 17)
	F03	166 > 113 (31, 34)	99 = 79 (37, 26)	101 < 152 (31, 54)	54 = 52 (10, 11)	187 = 179 (46, 49)	99 = 81 (47, 32)
	F04	118 > 77 (17, 8)	83 = 97 (37, 36)	97 < 129 (11, 38)	60 = 57 (9, 6)	168 = 181 (43, 39)	114 = 116 (51, 36)
	M05	68 = 62 (13, 13)	68 = 66 (16, 5)	66 = 74 (7, 14)	58 = 59 (7, 10)	97 = 95 (7, 6)	46 = 43 (4, 9)



a (C.C.)	C1-/m/		V1-/v/	C2-/m/		V2-/l/	C3-/m/		V3-/a/	
	F	R		F	R		F	R		
S1 (stress-initial)	F01	98 < 106 (6, 8)	45 = 42 (5, 5)	137 = 138 (12, 16)	83 = 85 (8, 7)	39 = 41 (5, 8)	143 = 140 (8, 7)	75 = 72 (4, 14)	77 > 45 (14, 12)	164 = 157 (11, 22)
	F02	132 = 132 (10, 27)	74 = 79 (5, 14)	199 = 197 (20, 28)	91 = 90 (6, 13)	41 = 41 (9, 18)	156 = 149 (31, 24)	87 > 70 (6, 16)	87 > 62 (12, 16)	157 > 109 (18, 23)
	F03	116 < 124 (8, 7)	82 = 78 (4, 12)	205 = 212 (38, 18)	102 = 95 (5, 16)	56 = 53 (13, 16)	166 = 169 (21, 24)	88 > 69 (11, 15)	72 > 44 (18, 13)	145 > 120 (19, 15)
	F04	117 = 122 (13, 10)	70 = 69 (5, 6)	185 = 181 (14, 19)	100 = 97 (7, 6)	42 > 36 (4, 6)	182 > 165 (8, 8)	90 > 66 (14, 7)	89 > 47 (8, 8)	163 > 112 (32, 14)
	M05	83 = 86 (11, 3)	77 = 69 (5, 13)	190 = 186 (13, 30)	70 < 77 (4, 8)	53 = 56 (6, 11)	138 > 131 (7, 8)	64 = 58 (14, 11)	104 > 86 (12, 20)	181 = 176 (12, 19)
S2 (stress-medial)	F01	84 = 81 (7, 5)	36 < 42 (4, 3)	118 < 128 (5, 12)	91 = 97 (7, 7)	46 < 53 (5, 8)	174 = 174 (11, 13)	98 = 103 (9, 10)	80 > 52 (18, 11)	177 = 159 (18, 33)
	F02	87 = 83 (11, 5)	66 = 66 (7, 2)	168 = 177 (32, 35)	102 = 111 (11, 15)	73 > 59 (11, 10)	205 = 170 (46, 51)	101 > 84 (9, 9)	98 > 45 (12, 16)	160 > 118 (23, 16)
	F03	95 = 92 (7, 4)	41 < 46 (5, 3)	142 = 159 (13, 26)	112 = 115 (13, 13)	56 = 54 (10, 10)	204 = 193 (13, 11)	118 > 89 (9, 12)	60 = 50 (14, 7)	168 = 150 (13, 29)
	F04	104 = 105 (8, 10)	44 = 46 (2, 4)	122 < 135 (6, 8)	106 = 100 (7, 9)	62 = 58 (5, 4)	233 > 207 (17, 24)	117 > 89 (7, 9)	96 > 51 (5, 14)	192 > 143 (57, 32)
	M05	66 = 67 (8, 18)	48 = 52 (6, 8)	148 = 149 (9, 15)	68 = 75 (8, 10)	72 = 74 (9, 7)	165 = 164 (11, 14)	87 = 83 (7, 8)	87 = 75 (17, 17)	205 > 193 (13, 13)
S3 (stress-final)	F01	74 = 78 (7, 7)	34 = 35 (3, 3)	92 = 98 (8, 9)	65 = 69 (5, 8)	39 = 37 (5, 4)	138 = 140 (7, 7)	79 < 88 (4, 8)	88 > 72 (5, 19)	200 > 174 (22, 25)
	F02	64 < 77 (12, 14)	51 = 54 (8, 9)	115 = 120 (22, 21)	64 = 69 (13, 18)	45 = 45 (20, 15)	173 = 170 (22, 21)	100 = 115 (16, 29)	100 > 69 (11, 12)	196 = 186 (24, 36)
	F03	79 = 79 (11, 7)	41 = 46 (5, 6)	118 = 132 (13, 21)	71 = 79 (10, 8)	53 = 51 (8, 8)	152 = 164 (6, 21)	115 > 107 (9, 8)	82 > 60 (5, 8)	186 > 158 (11, 18)
	F04	109 = 111 (10, 17)	41 = 41 (6, 5)	118 = 126 (21, 19)	76 = 73 (14, 7)	41 = 40 (5, 7)	174 = 167 (13, 8)	104 = 100 (15, 15)	105 > 65 (8, 7)	191 > 153 (25, 23)
	M05	65 = 68 (5, 10)	45 = 51 (6, 8)	119 = 126 (14, 14)	63 = 62 (12, 8)	46 = 45 (10, 8)	140 = 141 (19, 12)	72 = 76 (10, 12)	106 = 102 (12, 17)	223 > 201 (11, 14)

b (CC)	C4-/m/		C5-/t/		C6-/ks/		
	F	R	F	R	F	R	
S1 (stress-initial)	F01	118 > 70 (35, 6)	107 > 76 (17, 22)	72 < 89 (10, 10)	49 > 38 (10, 9)	88 > 78 (11, 6)	75 = 68 (10, 7)
	F02	162 > 72 (64, 11)	93 = 94 (19, 26)	89 < 126 (18, 47)	65 = 57 (21, 17)	72 < 86 (14, 12)	74 = 59 (32, 18)
	F03	131 > 90 (31, 18)	88 = 86 (35, 32)	106 = 115 (26, 25)	53 = 54 (8, 7)	178 = 212 (51, 36)	89 = 82 (43, 33)
	F04	105 > 64 (17, 17)	69 = 70 (18, 30)	99 = 105 (14, 21)	62 = 59 (7, 6)	183 = 179 (36, 33)	83 < 113 (32, 31)
	M05	70 > 56 (12, 9)	74 = 63 (23, 7)	70 = 80 (12, 17)	57 = 59 (14, 8)	99 = 96 (3, 8)	42 = 40 (5, 7)
S2 (stress-medial)	F01	128 > 79 (43, 12)	93 > 74 (23, 16)	83 = 85 (10, 16)	49 = 53 (9, 16)	89 = 80 (12, 11)	75 > 66 (5, 10)
	F02	126 > 81 (42, 24)	92 < 116 (18, 30)	80 < 108 (13, 25)	62 = 64 (31, 14)	80 < 93 (12, 13)	68 = 60 (16, 17)
	F03	125 > 91 (30, 28)	79 = 80 (21, 30)	110 = 129 (24, 19)	54 = 50 (4, 8)	150 = 175 (32, 60)	120 = 106 (33, 43)
	F04	111 > 71 (12, 30)	79 = 78 (15, 33)	94 < 117 (12, 22)	57 = 59 (5, 5)	191 = 185 (20, 45)	87 = 87 (32, 38)
	M05	71 = 62 (29, 15, ns)	69 > 56 (19, 6)	74 = 70 (11, 13)	55 = 58 (12, 8)	99 = 95 (6, 4)	44 = 41 (5, 6)
S3 (stress-final)	F01	134 = 93 (68, 13)	94 = 82 (24, 24)	72 < 93 (11, 12)	52 = 45 (13, 10)	94 > 84 (9, 10)	70 = 65 (12, 6)
	F02	127 > 89 (28, 15)	102 > 70 (30, 7)	93 = 94 (14, 8)	61 = 71 (18, 16)	88 = 84 (15, 12)	66 = 65 (29, 17)
	F03	174 > 113 (27, 34)	75 = 79 (18, 26)	94 < 152 (7, 54)	55 = 52 (10, 11)	163 = 179 (49, 49)	107 = 81 (41, 32)
	F04	110 > 77 (16, 8)	99 = 97 (35, 36)	92 < 129 (8, 38)	59 = 57 (6, 6)	158 = 181 (48, 39)	107 = 116 (31, 36)
	M05	59 = 62 (7, 13)	64 = 66 (11, 5)	67 = 74 (7, 14)	57 = 59 (5, 10)	96 = 95 (5, 6)	43 = 43 (6, 9)

a (PC)	C1-/m/		V1-/v/	C2-/m/		V2-/l/	C3-/m/		V3-/a/	
	F	R		F	R		F	R		
S1 (stress-initial)	F01	98 < 106 (11, 8)	44 = 42 (3, 5)	129 = 138 (7, 16)	82 = 85 (9, 7)	40 = 41 (6, 8)	140 = 140 (8, 7)	84 > 72 (7, 14)	58 > 45 (20, 12)	177 = 157 (37, 22)
	F02	117 = 132 (21, 27)	79 = 79 (10, 14)	183 = 197 (18, 28)	84 = 90 (6, 13)	44 = 41 (7, 18)	153 = 149 (30, 24)	79 = 70 (8, 16)	98 > 62 (16, 16)	156 > 109 (11, 23)
	F03	117 = 124 (9, 7)	76 = 78 (6, 12)	204 = 212 (14, 18)	101 = 95 (6, 16)	61 = 53 (5, 16)	187 = 169 (18, 24)	89 > 69 (9, 15)	68 > 44 (12, 13)	164 > 120 (16, 15)
S2 (stress-medial)	F04	NA	NA	NA	NA	NA	NA	NA	NA	NA
	M05	91 = 86 (4, 13)	61 = 69 (9, 13)	175 = 186 (13, 30)	79 = 77 (7, 8)	51 = 56 (7, 11)	135 = 131 (14, 8)	61 = 58 (8, 11)	93 = 86 (23, 20)	169 < 176 (19, 19)
	F01	81 = 81 (4, 5)	43 = 42 (4, 3)	121 = 128 (9, 12)	88 < 97 (8, 7)	42 < 53 (6, 8)	158 < 174 (12, 13)	96 < 103 (8, 10)	70 > 52 (16, 11)	183 = 159 (47, 33)
	F02	97 = 83 (19, 5)	68 = 66 (8, 2)	172 = 177 (17, 35)	110 = 111 (14, 15)	74 > 59 (7, 10)	206 = 170 (37, 51)	99 > 84 (5, 9)	91 > 45 (17, 16)	152 > 118 (16, 16)
	F03	95 = 92 (15, 4)	47 = 46 (8, 3)	141 = 159 (10, 26)	116 = 115 (8, 13)	61 = 54 (12, 10)	220 > 193 (18, 11)	122 > 89 (14, 12)	72 > 50 (24, 7)	173 = 150 (12, 29)
S3 (stress-final)	F04	NA	NA	NA	NA	NA	NA	NA	NA	NA
	M05	69 = 67 (8, 18)	50 = 52 (7, 8)	151 = 149 (10, 15)	70 = 75 (8, 10)	70 = 74 (7, 7)	153 < 164 (11, 14)	87 = 83 (6, 8)	78 = 75 (13, 17)	193 = 193 (19, 13)
	F01	79 = 78 (10, 7)	39 = 35 (5, 3)	98 = 98 (5, 9)	67 = 69 (5, 8)	38 = 37 (4, 4)	134 < 140 (6, 7)	85 = 88 (4, 6)	87 = 72 (16, 19)	209 > 174 (19, 25)
	F02	76 = 77 (16, 14)	52 = 54 (10, 9)	116 = 120 (21, 21)	71 = 69 (15, 18)	46 = 45 (11, 15)	152 = 170 (36, 21)	109 = 115 (13, 29)	100 > 69 (9, 12)	205 = 186 (40, 36)
	F03	77 = 79 (4, 7)	45 = 46 (4, 6)	112 = 132 (19, 21)	71 < 79 (7, 8)	52 = 51 (8, 8)	158 = 164 (9, 21)	117 > 107 (4, 8)	81 > 60 (5, 8)	203 > 158 (16, 18)
F04	NA	NA	NA	NA	NA	NA	NA	NA	NA	
M05	70 = 68 (7, 10)	45 = 51 (6, 8)	119 = 126 (8, 14)	65 = 62 (7, 8)	38 < 45 (4, 8)	142 = 141 (11, 12)	89 > 76 (12, 12)	103 = 102 (16, 17)	194 = 201 (14, 14)	

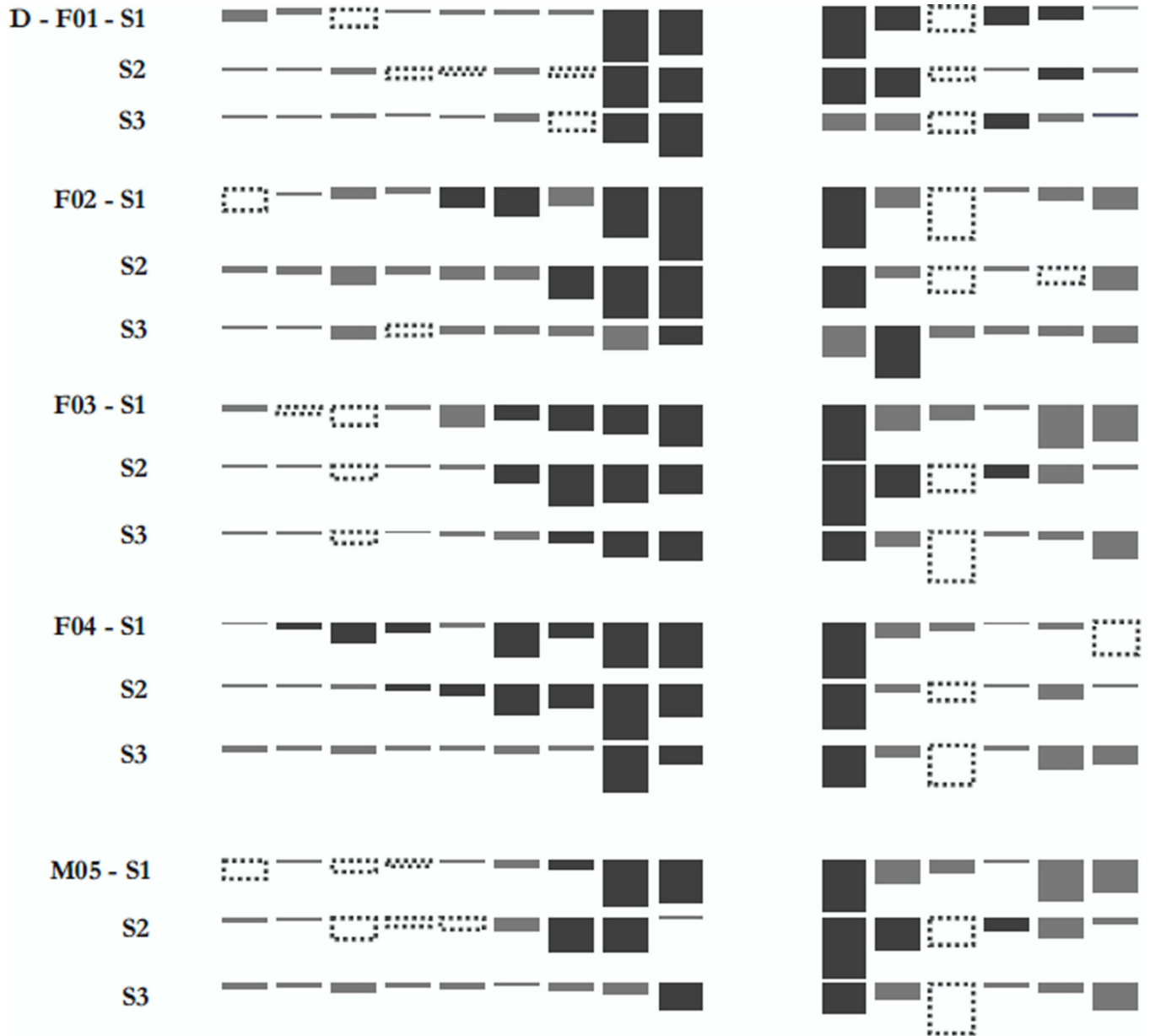


b (PC)	C4-/m/		C5-/t/		C6-/ks/		
	F	R	F	R	F	R	
S1 (stress-initial)	F01	97 > 70 (25, 6)	95 = 76 (29, 22)	82 = 89 (13, 10)	46 = 38 (14, 9)	85 = 78 (10, 6)	68 = 68 (10, 7)
	F02	128 > 72 (35, 11)	112 = 94 (24, 26)	97 = 126 (28, 47)	75 = 57 (30, 17)	83 = 86 (14, 12)	63 = 59 (27, 18)
	F03	119 > 90 (16, 18)	75 = 86 (20, 32)	97 = 115 (13, 25)	52 = 54 (7, 7)	185 = 212 (49, 36)	87 = 82 (40, 33)
	F04	93 > 64 (28, 17)	84 = 70 (27, 30)	103 = 105 (35, 21)	59 = 59 (8, 6)	195 = 179 (34, 33)	93 = 113 (24, 31)
	M05	57 = 56 (10, 9)	86 > 63 (29, 7)	82 = 80 (20, 17)	52 = 59 (10, 8)	96 = 96 (5, 8)	41 = 40 (5, 7)
S2 (stress-medial)	F01	105 > 79 (21, 12)	89 = 74 (30, 16)	90 = 85 (17, 16)	47 = 53 (10, 16)	93 = 80 (29, 11)	64 = 66 (9, 10)
	F02	120 > 81 (42, 24)	119 = 116 (25, 30)	103 = 108 (61, 25)	75 = 64 (23, 14)	76 < 93 (9, 13)	66 = 60 (13, 17)
	F03	110 = 91 (27, 28)	96 = 80 (34, 30)	133 = 129 (31, 19)	51 = 50 (8, 8)	179 = 175 (61, 60)	83 = 106 (33, 43)
	F04	81 = 71 (23, 30)	78 = 78 (34, 33)	116 = 117 (38, 22)	60 = 59 (9, 5)	205 = 185 (22, 45)	76 = 87 (12, 38)
	M05	70 = 62 (25, 15)	66 = 56 (22, 6)	79 = 70 (11, 13)	56 = 58 (8, 8)	98 = 95 (9, 4)	44 = 41 (7, 6)
S3 (stress-final)	F01	133 > 93 (40, 13)	86 = 82 (29, 24)	100 = 93 (31, 12)	47 = 45 (12, 10)	83 = 84 (8, 10)	69 = 65 (12, 6)
	F02	136 > 89 (43, 15)	91 > 70 (21, 7)	89 = 94 (14, 8)	64 = 71 (15, 16)	92 = 84 (18, 12)	64 = 65 (33, 17)
	F03	146 > 113 (33, 34)	91 = 79 (28, 26)	107 = 152 (18, 54)	47 = 52 (7, 11)	168 = 179 (50, 49)	93 = 81 (33, 32)
	F04	110 > 77 (23, 8)	71 = 97 (17, 36)	93 < 129 (11, 38)	58 = 57 (4, 6)	192 = 181 (20, 39)	106 = 116 (33, 36)
	M05	74 = 62 (20, 13)	66 = 66 (9, 5)	73 = 74 (17, 14)	58 = 59 (6, 10)	95 = 95 (7, 6)	45 = 43 (3, 9)

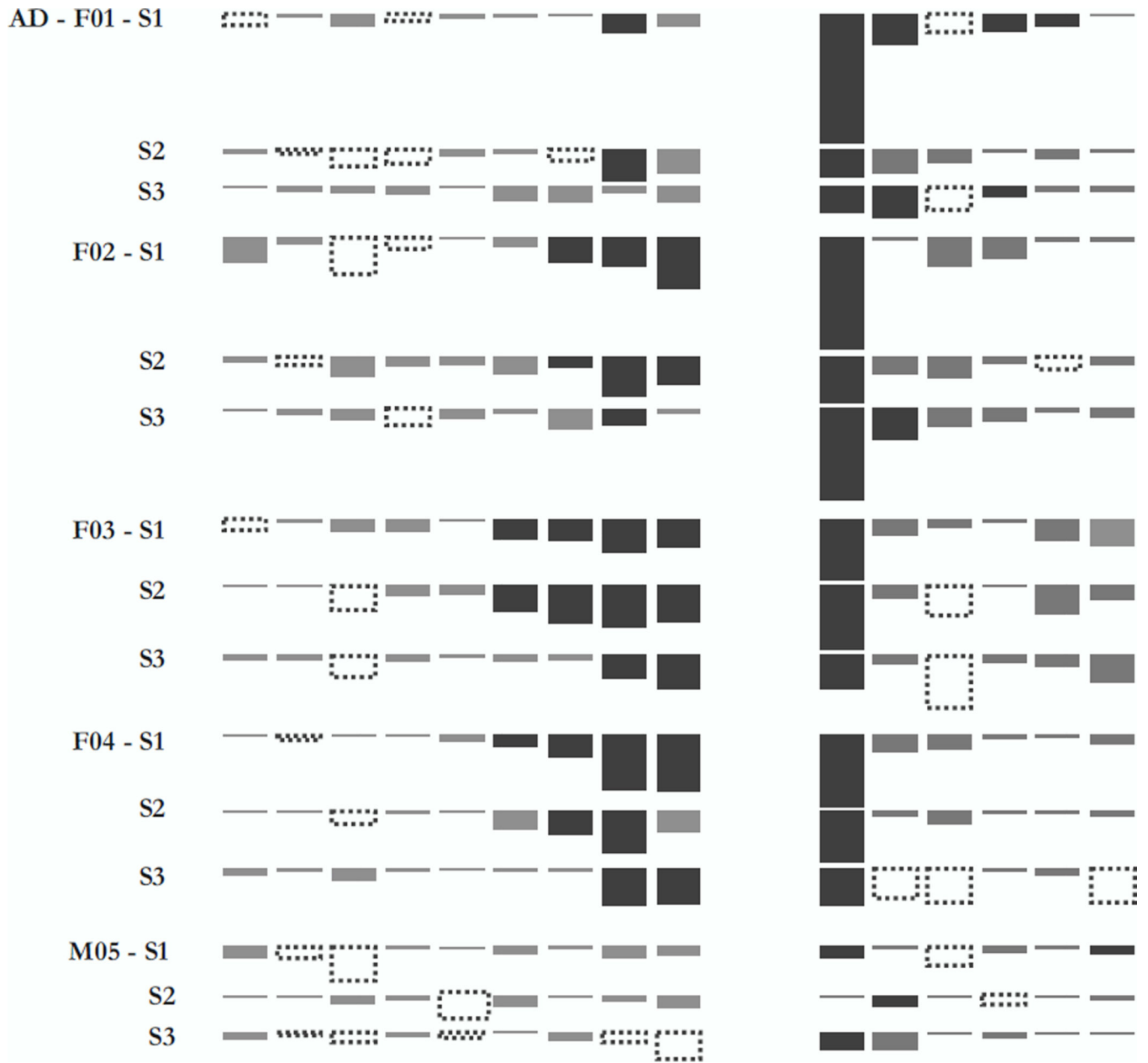
## Appendix B

Figures B1-B5. Schematic illustration of the difference in duration (in ms) between the constriction gestures of the IP<sub>1</sub>-final (pre-boundary) and IP<sub>2</sub>-initial (post-boundary) words and their W counterparts for each Stress (S1, S2, S3) per speaker for each syntactic construction. In each row, boxes stand for gestures presented in the orthographic order of the

test words (i.e., pre-boundary order: C1-FC1-RV1, C2-FC2-RV2, C2-FC2-RV2, C3-FC3-RV3; post-boundary order: C4-FC4-RC5-FC5-RC6-F, and C6-R). Black boxes represent longer IP than W gestures (lengthening), white boxes in broken black borders shorter IP than W gestures (shortening), and gray boxes stand for no statistically significant difference between IP and W gestures.

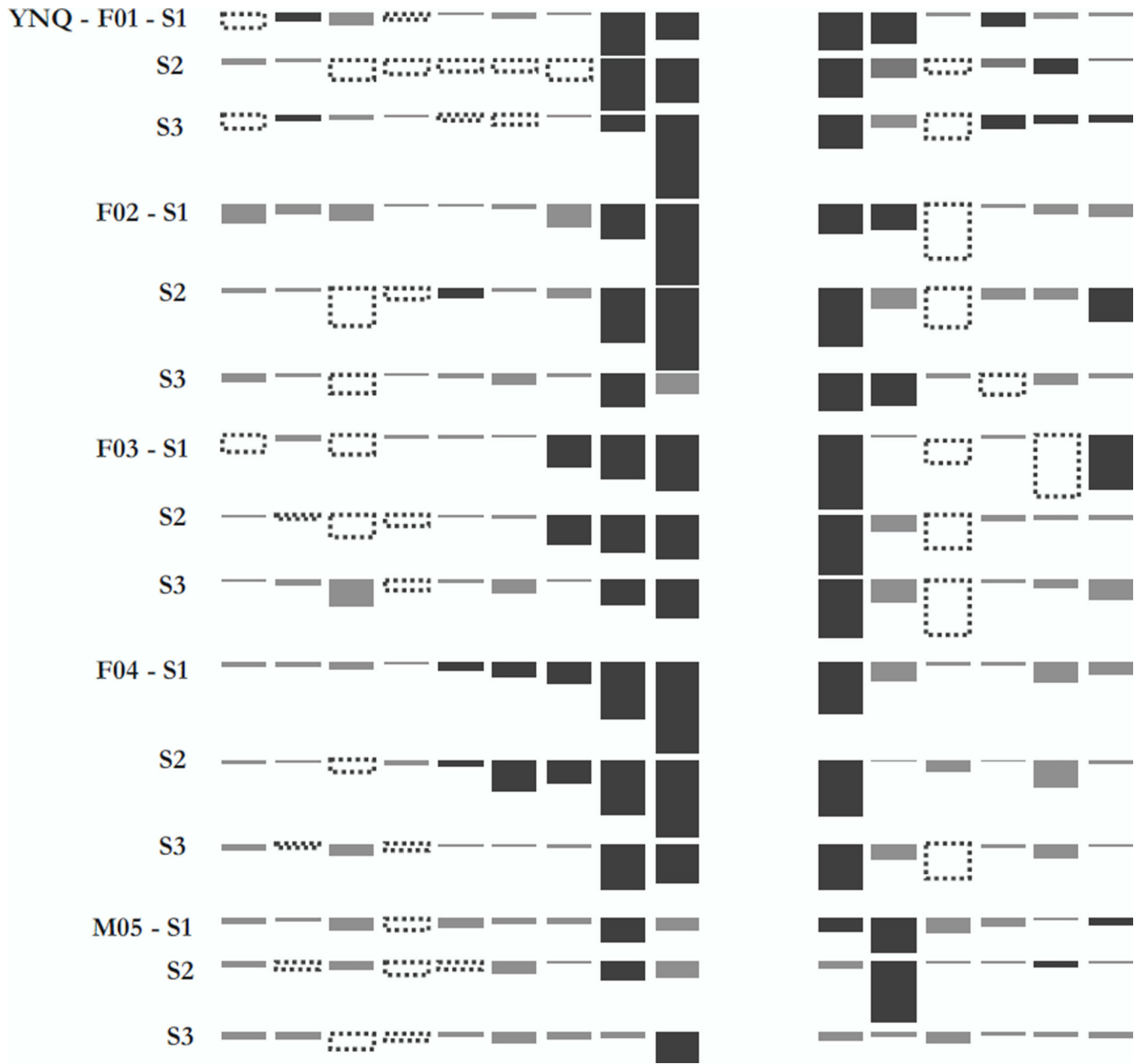


B1) De-accented constructions (D)

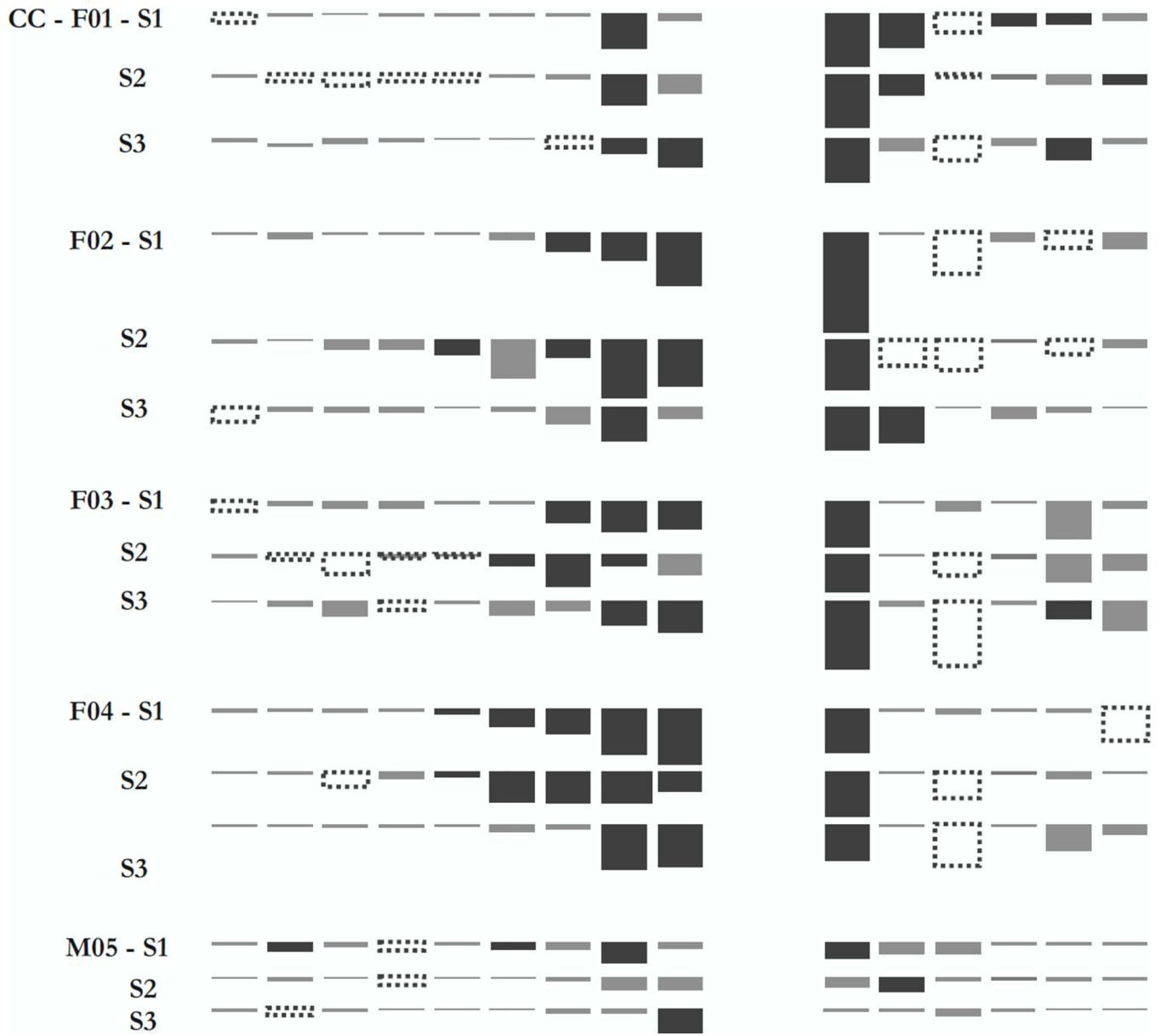


B2) Affirmative declaratives (AD)

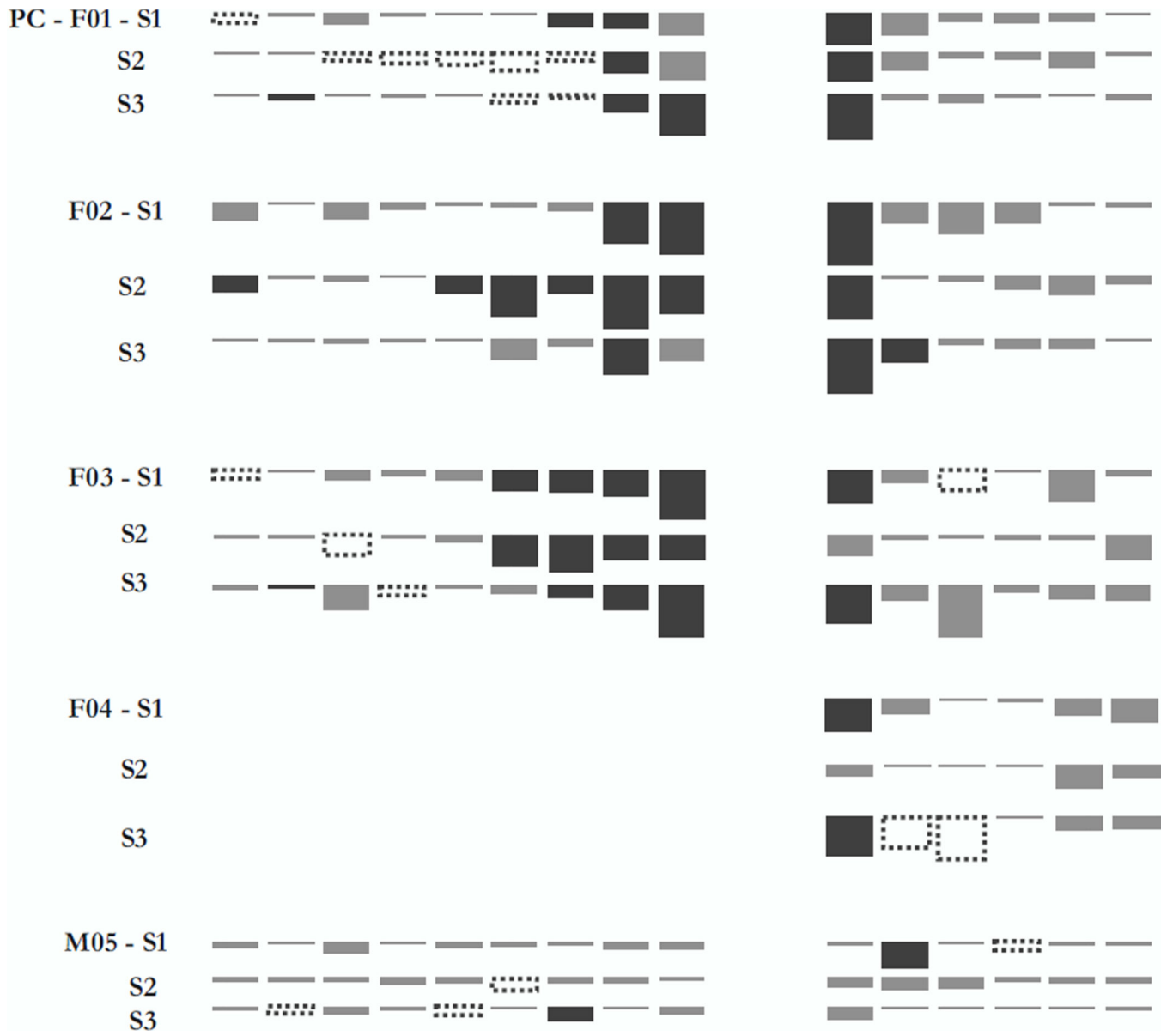




B3) Yes-no questions (YNQ)



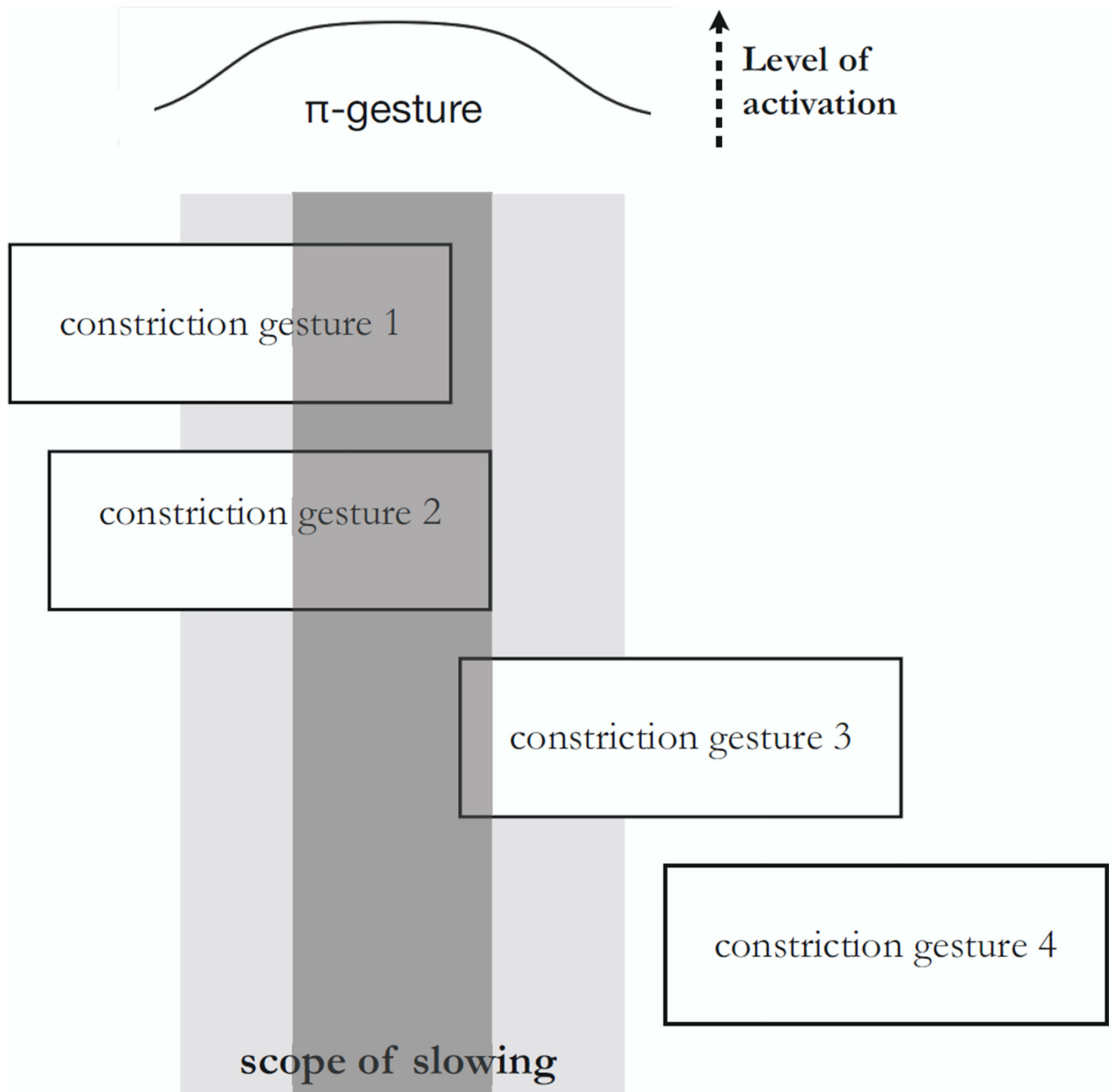
B4) Causative clauses (CC)



B5) Parenthetical clauses (PC)

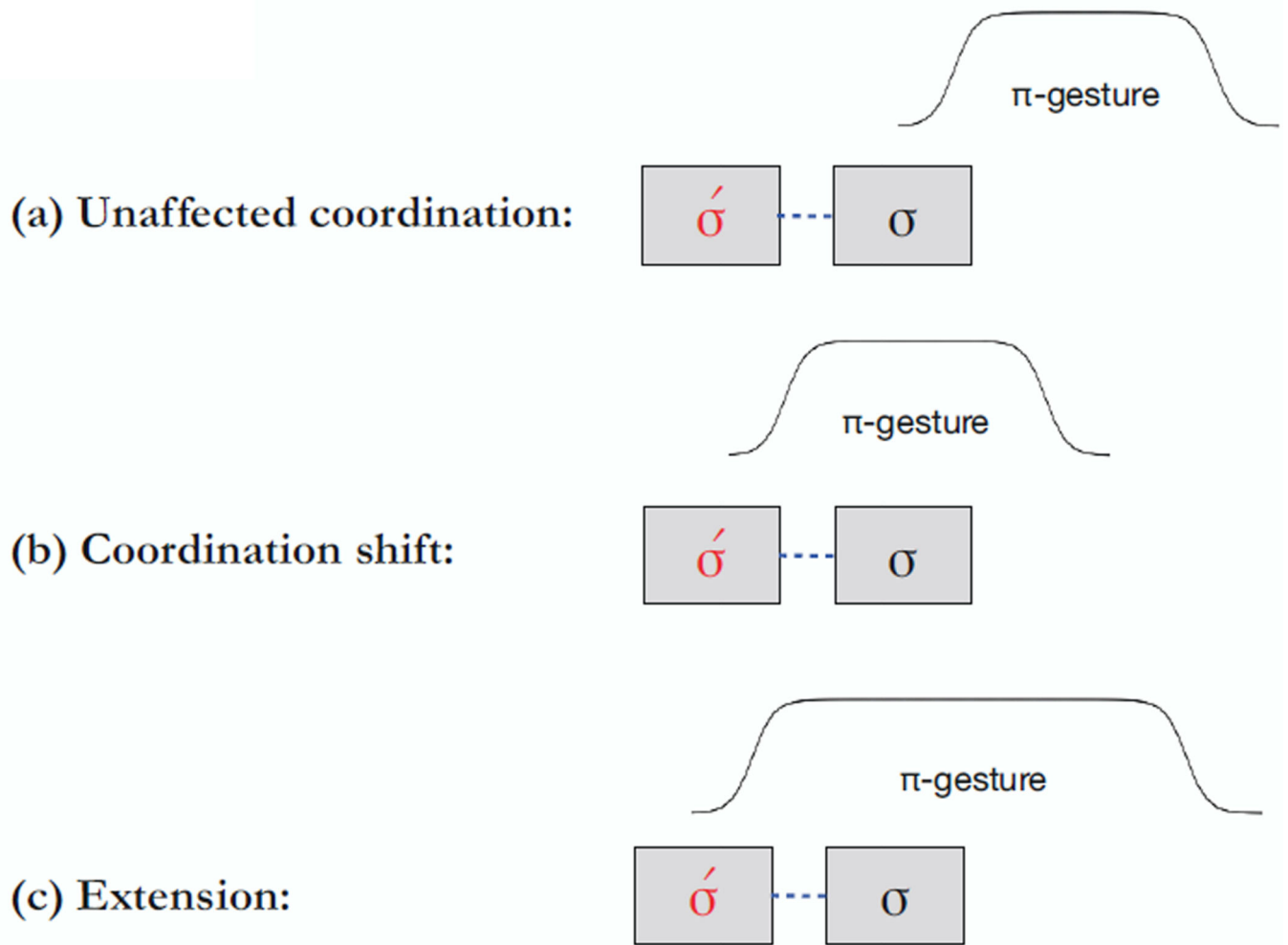
**Highlights**

- Lexical stress affects the initiation of phrase-final lengthening.
- Pitch accent does not affect the scope of phrase-final lengthening.
- Lexical stress affects the duration of pause posture formation.
- Lexical stress affects the distribution of boundary-related shortening.
- The domain of boundary-related lengthening is continuous.



**Figure 1.**

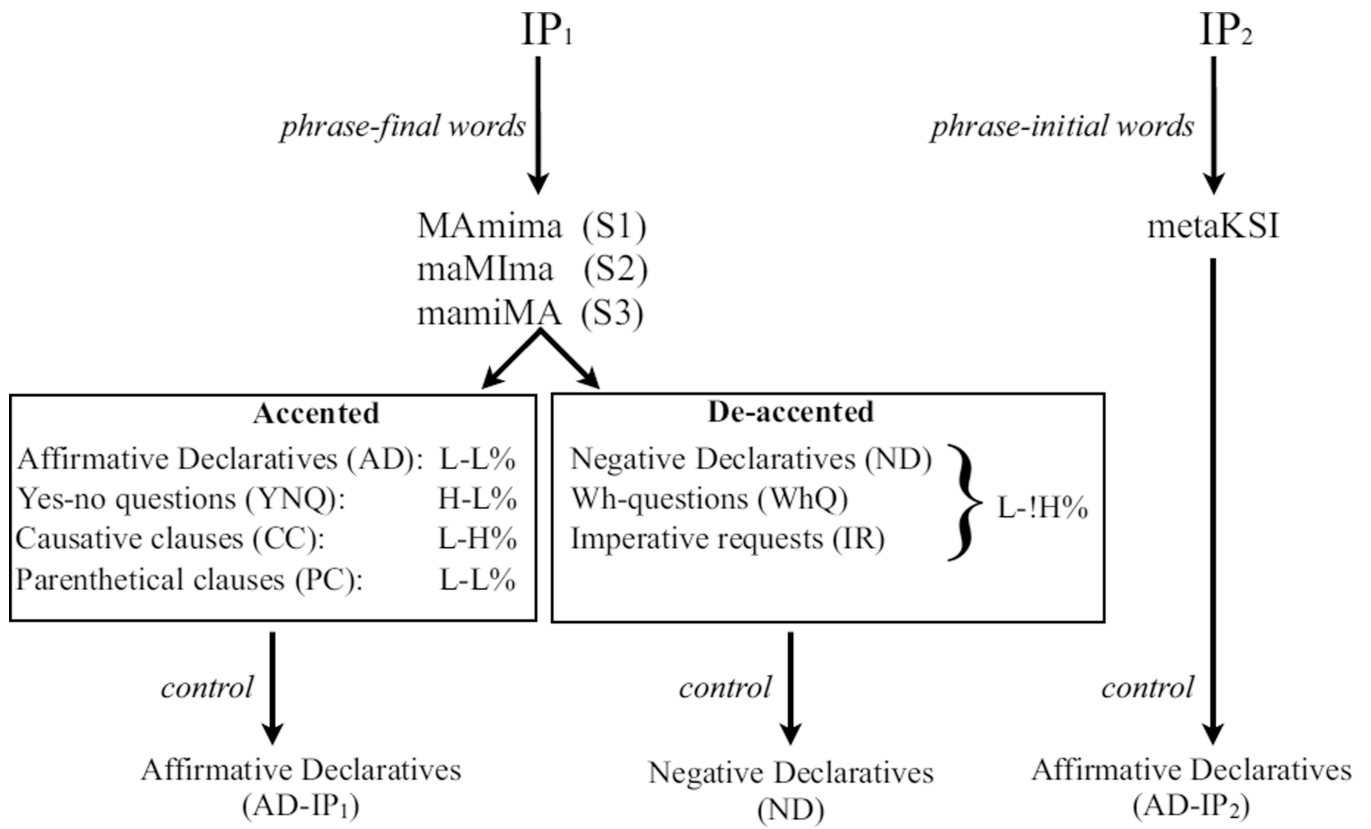
A schematic representation of a  $\pi$ -gesture (adapted from Byrd & Saltzman, 2003). The two-shade gray box represents the scope of slowing caused by the  $\pi$ -gesture, with darker gray corresponding to the  $\pi$ -gesture's maximal level of activation. Constriction gestures co-active with the  $\pi$ -gesture (1 and 2 pre-boundary; 3 post-boundary) undergo slowing. Constriction gesture 4 does not overlap with the  $\pi$ -gesture, and is thus unaffected by boundary-related effects.



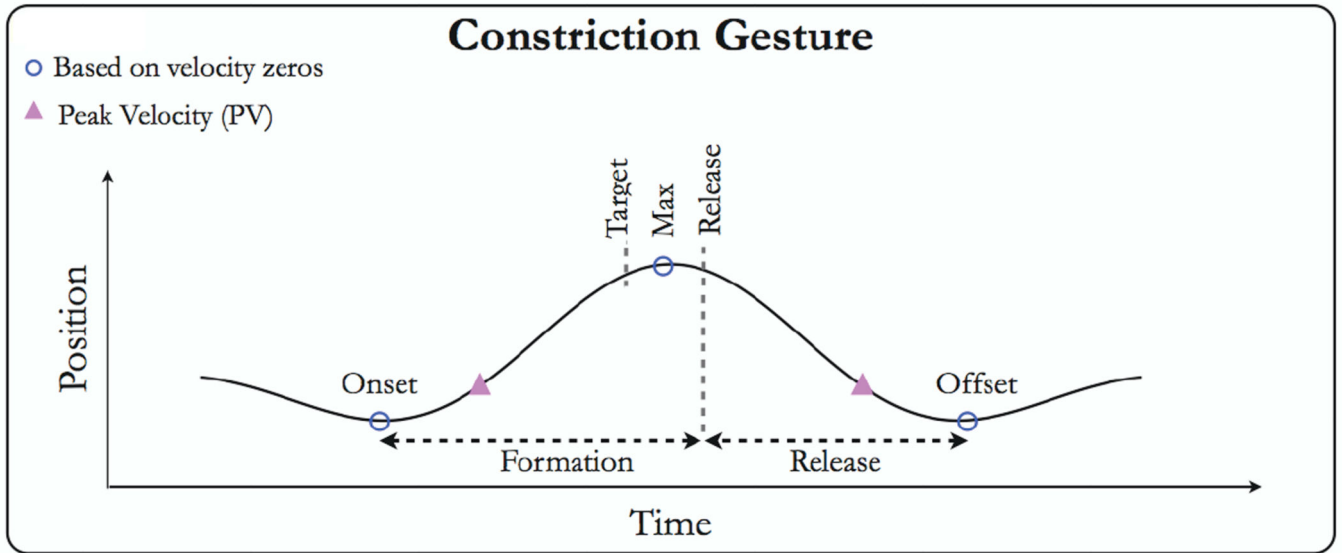
**Figure 2.**

The three possible coordination alternatives for a  $\pi$ -gesture with the phrase-final words (adapted from Byrd & Riggs, 2008). The words used in this figure are disyllabic stressed on the penult. Syllables are represented by '  $\sigma$  ', and stress by '  $\acute{\sigma}$  '.

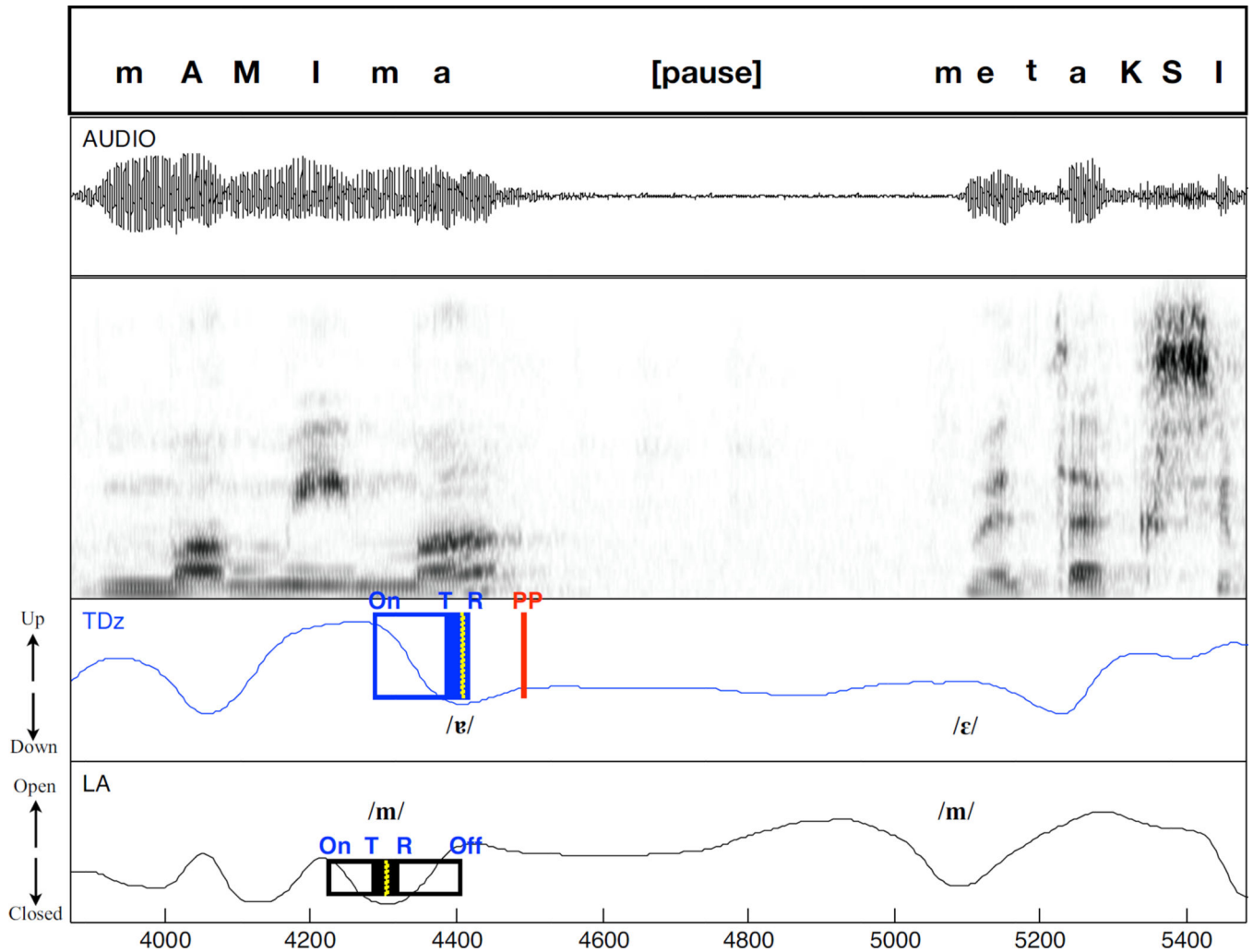




**Figure 3.**  
Experimental Design

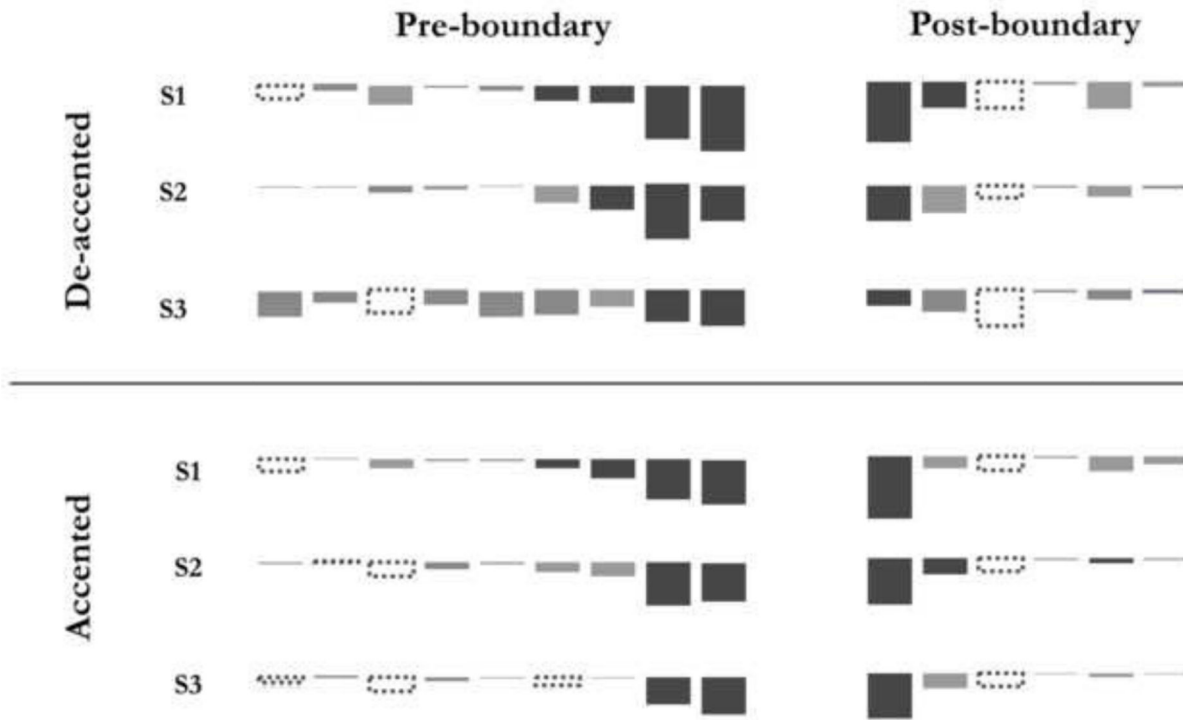


**Figure 4.**  
Kinematic landmarks for constriction gestures



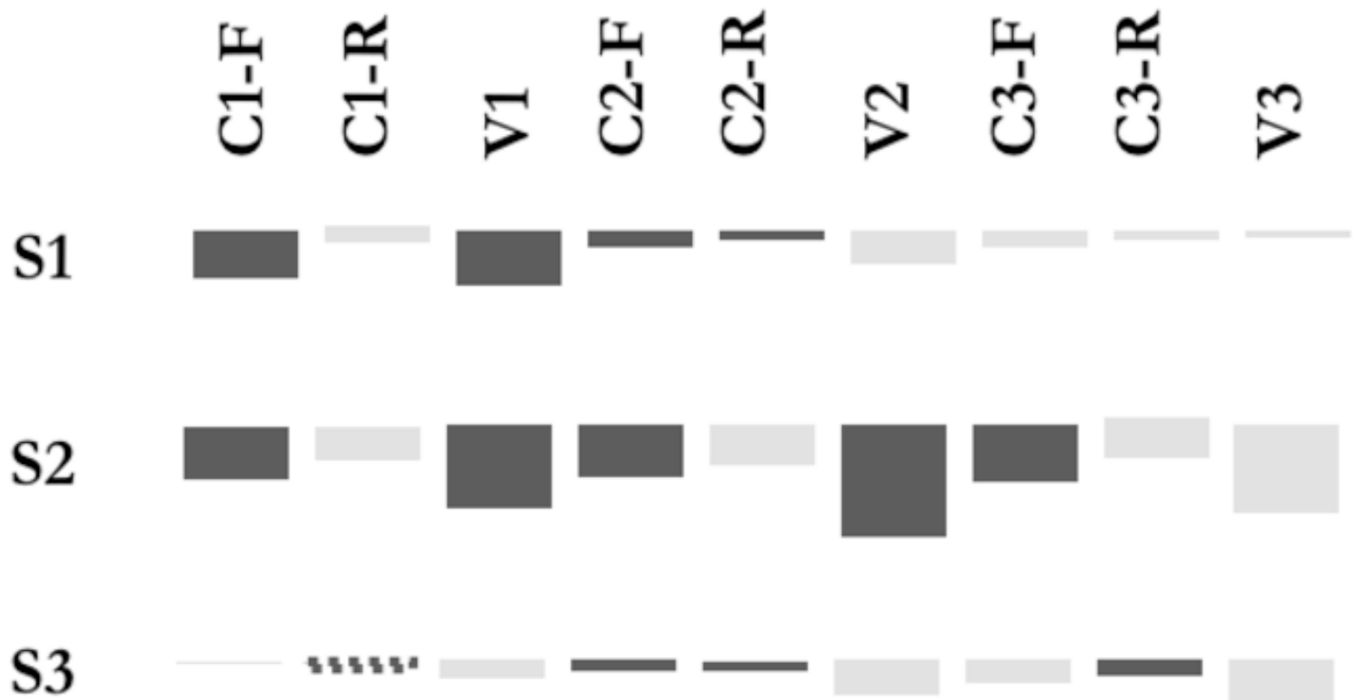
**Figure 5.**

The waveform, spectrogram, tongue dorsum vertical displacement (TDz) and lip aperture (LA) in a de-accented (WhQ) stress-medial (S2: maMIma) condition of speaker F04. The part of the token shown includes the IP<sub>1</sub>-final word, the IP<sub>2</sub>-initial word and the inter-phrasal pause. The kinematic labels for the IP<sub>1</sub>-final C (/m/) and V (/e/) and for the pause posture (PP) formation are shown. For the C and V, the beginning of the empty box marks the onset (On), the beginning and end of the solid box mark the target (T) and release (R) respectively, and the vertical broken yellow line within the solid box marks the maximal constriction. The C (/m/) and V (/e/) articulatory targets of the IP<sub>2</sub>-initial syllable are approximately located by the means of their phonetic symbols.

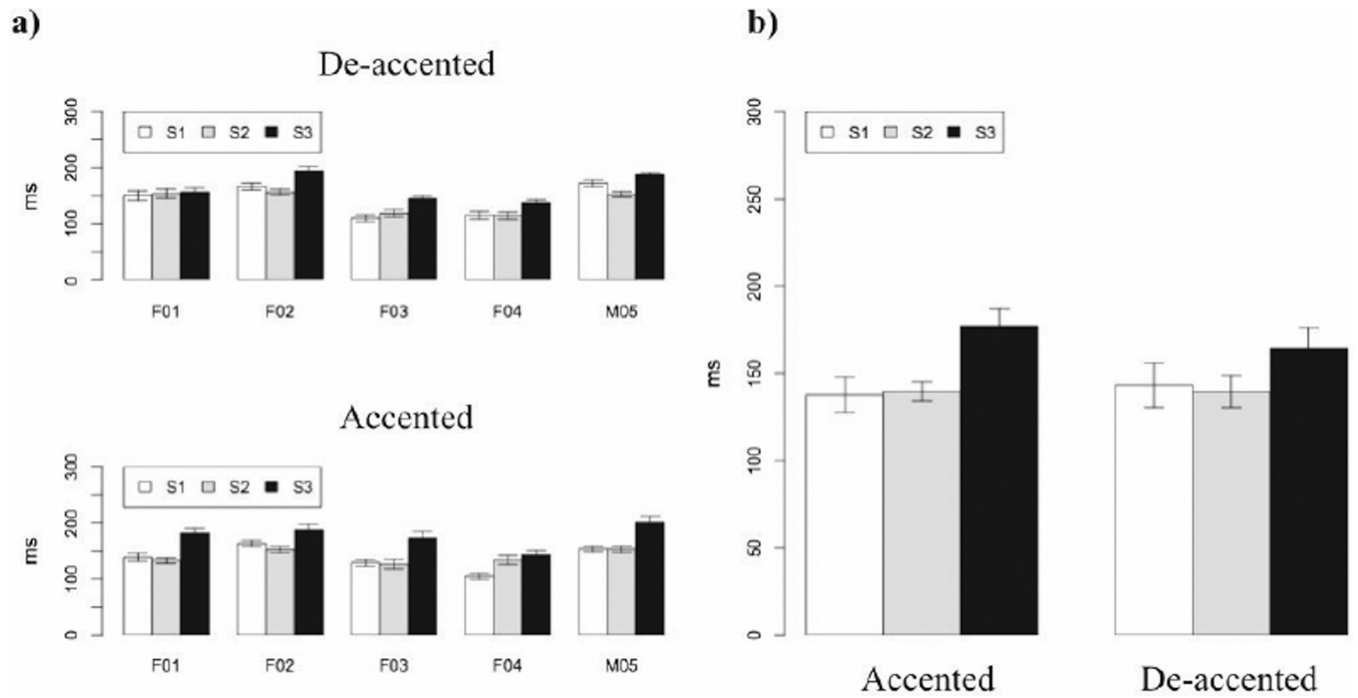


**Figures 6.**

Schematic illustration of the difference in duration (in ms) between the constriction gestures of the IP<sub>1</sub>-final (pre-boundary) and IP<sub>2</sub>-initial (post-boundary) words and their W counterparts for each STRESS (S1, S2, S3) in de-accented and accented constructions. In each row, boxes stand for gestures presented in the orthographic order of the test words (i.e., pre-boundary order: C1-FC1-RV1, C2-FC2-RV2, C2-FC2-RV2, C3-FC3-RV3; post-boundary order: C4-FC4-RC5-FC5-RC6-F, and C6-R). Black boxes represent longer IP than W gestures (lengthening), white boxes in broken black borders shorter IP than W gestures (shortening), and light gray boxes stand for no significant difference between IP and W gestures.

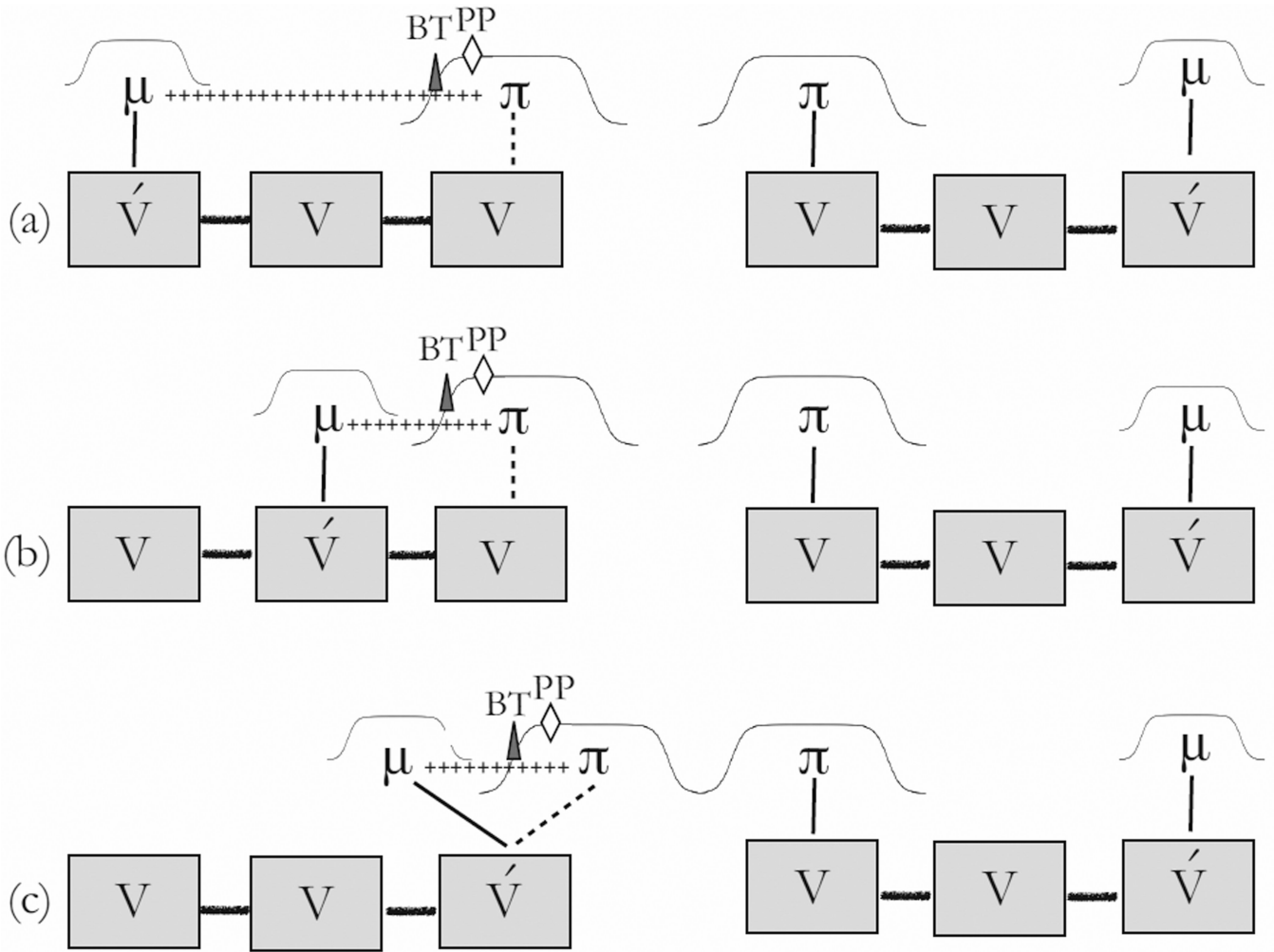


**Figure 7.** Schematic illustration of the difference in duration (in ms) between the constriction gestures of accented (A; only CC) and de-accented (D; pooled ND, WhQ and IR) IP<sub>1</sub>-final words. Black boxes represent longer A than D gestures, white boxes in broken black borders represent shorter A than D gestures, and gray boxes stand for no statistically significant difference between IP and W gestures.



**Figures 8.**  
The duration (in ms; with standard error) of pause posture formation as a function of STRESS and ACCENT per speaker (a) and across speakers (b).





**Figures 9.**

Schematic representation of phrase-final and phrase-initial  $\pi$ -gestures and their coordination in the context of stress-initial (a), stress-medial (b) and stress-final (c) phrase-final words respectively. Steadily solid lines represent in-phase coordination, broken lines represent anti-phase coordination, and lines of crosses represent currently uncertain types of coordination. Stress is represented by ' '. Gray triangles and white diamonds correspond to the strength levels of  $\pi$ -gesture activation that triggers boundary tone gestures (BT) and pause postures (PP) respectively. The activation intervals of  $\mu$ -gestures are symbolic, and should not be compared to the activation intervals of the  $\pi$ -gestures. This model is an extension of the proposal in Katsika et al. (2014).

Table 1

The stimuli for stress-initial words (MAMima). A rough translation into English of the context sentence (if present) is given first, and the target sentence in IPA along with a rough translation into English follows. The words bearing the nuclear pitch accent are marked with bold letters. Punctuation marks stand for phrase boundaries.

(1) Negative Declarative Showing Reservation (ND): <i>What they are doing is horrible!</i> <b>ðe</b> ðj̥ e ci' nun ' e kə pi' mē mime . me tē 'ksi mē θi' tō n kə r e me 'litse s pu' lun. It is not that they merchandize raw MAMima. It is just 'candies' they sell to students.
(2) Wh-Question (WhQ): <i>We are looking for raw MAMima</i> <b>pu</b> 'psə xne te ' j̥ e kə pi' mē mime ? me tē 'ksi mē θi' tō n e 'vr e ə s ðj̥ e ci' nite . Where are you looking for raw MAMima? Usually one can find some among students.
(3) Imperative Request (IR): <i>You seem as if you want to ask me for a favor.</i> 'vr e smu 'li j̥ i' e kə pi' mē mime . me tē 'ksi mē θi' tō n e 'vr e ə s ðj̥ e ci' nite . Find some raw MAMima for me. Usually one can find some among students.
(4) Affirmative Declarative (AD): <i>What are you looking for in our school?</i> e nē zi' tō ' e kə pi' <b>mē mime</b> . me tē 'ksi mē θi' tō n e 'vr e ə s ðj̥ e ci' nite . I am looking for raw MAMima. Usually one can find some among students.
(5) Yes-no question (YNQ): e nē zi' tē s ' e kə pi' <b>mē mime</b> ? me tē 'ksi mē θi' tō n e 'vr e ə s ðj̥ e ci' nite . Are you looking for raw MAMima? Usually one can find some among students.
(6) Causative clause (CC): e 'fu 'vr iskun ' e kə pi' <b>mē mime</b> , me tē 'ksi mē θi' tō n liciti tin ðj̥ e ci' nun. Since it happens to have in their possession raw MAMima, they merchandize it to students.
(7) Parenthetical Clause (PC): What do these people merchandize? <b>fi' te</b> – ' me lə n ' e kə pi' <b>mē mime</b> – me tē 'ksi mē θi' tō n j̥ imne ' siu ðj̥ e ci' nun. They merchandise plants - most likely raw MAMima - to high school students.
(8) Control Negative Declarative Showing Reservation (Control ND): <i>What they are doing is unacceptable!</i> <b>ðe</b> ðj̥ e ci' nun ' e kə pi' mē mime me tē 'ksi mē θi' tō n k j̥ e ' nilikə n e' fivə n. It is not that they merchandize raw MAMima to students and underage teenagers.
(9) Affirmative declarative, pre-boundary control (AD-IP <sub>1</sub> ): What types of narcotic plants do they merchandize to students and underage teenagers? ðj̥ e ci' nune ' e kə pi' <b>mē mime</b> me tē 'ksi mē θi' tō n k j̥ e ' nilikə n e' fivə n. They merchandize raw MAMima to students and underage teenagers.
(10) Affirmative declarative, post-boundary control (AD-IP <sub>2</sub> ): To whom do they merchandize raw MAMima? ðj̥ e ci' nune ' e kə pi' mē mime <b>me tē 'ksi mē θi' tō n k j̥ e ' nilikə n e' fivə n.</b> They merchandize raw MAMima to students and underage teenagers.

Table 2a and 2b

The planned t-test comparisons of the durations (in ms; with SD within parentheses underneath the respective durations) of the constriction gestures of the de-accented IP<sub>1</sub>-final words (2a: C1-V3) and their subsequent IP<sub>2</sub>-initial words (2b: C4-C6) across BOUNDARIES (IP vs. W) per Stress (S1, S2, S3) for each speaker (F01, F02, F03, F04 and M05). Dark gray and light gray cells represent significantly longer (>) and shorter (<) IP than W respectively (p < 0.05). White cells represent insignificant comparisons. Key: C = consonant, V = vowel, F = formation, R = release.

a	C1-/m/		V1-/w/	C2-/m/		V2-/l/	C3-/m/		V3-/a/	
	F	R		F	R		F	R		
S1 (stress-initial)	F01	90 = 101 (11, 6)	45 = 49 (5, 3)	131 < 146 (12, 9)	76 = 81 (6, 6)	38 = 39 (6, 5)	132 = 131 (9, 10)	71 = 70 (7, 10)	81 > 34 (12, 6)	172 > 130 (27, 15)
	F02	103 < 121 (14, 34)	74 = 74 (10, 10)	177 = 185 (19, 26)	84 = 80 (10, 5)	35 > 19 (12, 8)	149 > 123 (11, 18)	88 = 73 (18, 20)	91 > 46 (13, 8)	155 > 90 (16, 12)
	F03	102 = 103 (6, 4)	77 < 84 (7, 10)	196 < 212 (12, 19)	99 = 97 (6, 5)	55 < 73 (20, 45)	169 > 156 (12, 24)	95 > 73 (14, 17)	84 > 59 (10, 29)	151 > 115 (13, 13)
	F04	100 = 102 (8, 6)	69 > 63 (6, 6)	174 > 156 (12, 10)	92 > 83 (6, 5)	41 = 37 (4, 14)	161 > 130 (9, 19)	77 > 63 (8, 11)	88 > 46 (13, 16)	138 > 96 (26, 3)
	M05	76 < 93 (8, 12)	68 = 69 (7, 9)	177 < 188 (11, 8)	68 < 74 (7, 4)	49 = 50 (8, 4)	130 = 124 (11, 14)	57 > 47 (11, 9)	102 > 59 (12, 14)	177 > 137 (15, 18)
S2 (stress-medial)	F01	78 = 79 (8, 10)	40 = 41 (5, 4)	109 = 114 (10, 5)	78 < 87 (7, 7)	41 < 46 (6, 6)	147 = 152 (10, 11)	83 < 89 (7, 8)	83 > 45 (11, 8)	183 > 152 (28, 23)
	F02	79 = 83 (18, 32)	59 = 65 (9, 5)	144 = 128 (40, 18)	85 = 91 (13, 12)	65 > 55 (11, 8)	175 = 163 (41, 36)	95 > 66 (14, 8)	84 > 37 (15, 10)	157 > 110 (24, 16)
	F03	87 = 86 (7, 6)	42 = 43 (5, 7)	133 < 145 (9, 13)	104 = 103 (10, 11)	56 = 54 (7, 10)	203 > 186 (11, 14)	116 > 79 (8, 10)	80 > 46 (9, 7)	167 > 142 (18, 25)
	F04	99 = 96 (13, 7)	44 = 42 (6, 3)	119 = 123 (8, 10)	91 > 86 (6, 9)	62 > 52 (5, 4)	212 > 183 (16, 15)	100 > 79 (7, 10)	92 > 42 (10, 4)	157 > 127 (22, 21)
	M05	64 = 67 (8, 10)	47 = 52 (10, 5)	145 < 164 (10, 12)	63 < 70 (8, 9)	65 < 75 (11, 7)	156 > 145 (14, 12)	83 > 53 (11, 6)	84 > 53 (13, 6)	191 = 190 (18, 11)
S3 (stress-final)	F01	72 = 72 (10, 13)	38 = 37 (5, 5)	91 = 94 (12, 7)	65 = 66 (9, 5)	37 = 38 (8, 6)	126 = 132 (9, 6)	72 < 87 (6, 7)	85 > 59 (11, 12)	206 > 166 (29, 33)
	F02	72 = 69 (21, 13)	52 = 49 (6, 13)	93 = 104 (17, 15)	57 < 66 (10, 5)	43 = 36 (20, 13)	148 = 155 (19, 26)	99 = 91 (16, 29)	93 > 72 (9, 30)	183 > 166 (18, 24)
	F03	77 = 75 (7, 9)	41 = 44 (6, 5)	108 < 118 (12, 6)	71 = 72 (8, 8)	47 = 50 (7, 6)	158 = 151 (11, 10)	109 > 99 (10, 10)	80 > 57 (7, 5)	184 > 158 (10, 12)
	F04	103 = 108 (15, 18)	41 = 43 (4, 4)	117 = 123 (12, 10)	67 = 71 (5, 5)	40 = 37 (5, 4)	164 = 158 (9, 8)	92 = 89 (9, 14)	98 > 57 (5, 7)	158 > 143 (12, 16)
	M05	65 = 70 (10, 5)	46 = 44 (6, 6)	120 = 128 (15, 7)	56 = 52 (10, 7)	44 = 44 (10, 9)	130 = 130 (17, 7)	69 = 75 (12, 12)	100 = 91 (12, 26)	202 > 178 (21, 21)

b		C4-/m/		C5-/t/		C6-/ks/	
		F	R	F	R	F	R
S1 (stress-initial)	F01	118 > 70 (52, 6)	98 > 76 (29, 22)	75 < 89 (13, 10)	55 > 38 (12, 9)	91 > 78 (16, 6)	65 = 68 (14, 7)
	F02	126 > 72 (50, 11)	110 = 94 (25, 26)	81 < 126 (18, 47)	59 = 57 (25, 17)	76 < 86 (14, 12)	77 = 59 (29, 18)
	F03	138 > 90 (20, 18)	108 = 86 (37, 32)	103 = 115 (20, 25)	56 = 54 (13, 7)	175 < 213 (41, 36)	112 > 82 (36, 33)
	F04	115 > 64 (15, 17)	83 = 70 (28, 31)	98 = 105 (12, 20)	58 = 59 (8, 6)	174 = 179 (32, 33)	84 < 113 (40, 31)
	M05	68 = 56 (32, 9)	71 = 63 (18, 7)	65 < 77 (11, 17)	55 = 59 (8, 8)	95 = 96 (6, 8)	42 = 40 (5, 7)
S2 (stress-medial)	F01	111 > 79 (19, 12)	99 > 74 (26, 15)	74 < 85 (13, 16)	55 = 53 (11, 16)	91 > 81 (10, 11)	69 = 66 (11, 10)
	F02	118 > 81 (52, 24)	107 = 116 (31, 20)	85 < 108 (24, 25)	67 = 64 (31, 14)	78 < 93 (12, 13)	80 = 60 (35, 17)
	F03	145 > 91 (44, 28)	109 > 80 (34, 30)	105 < 129 (22, 19)	61 > 50 (10, 8)	192 = 175 (45, 60)	102 = 106 (40, 43)
	F04	111 > 71 (20, 30)	84 = 78 (22, 33)	102 < 117 (17, 22)	57 = 59 (5, 5)	172 = 185 (37, 46)	87 = 87 (33, 38)
	M05	69 = 62 (25, 15)	76 > 56 (26, 6)	68 = 74 (12, 13)	52 < 58 (10, 8)	95 = 95 (5, 4)	44 = 41 (6, 6)
S3 (stress-final)	F01	107 = 93 (25, 13)	96 = 82 (27, 24)	77 < 93 (10, 12)	58 > 45 (16, 10)	91 = 84 (15, 10)	65 = 65 (12, 6)
	F02	116 = 89 (43, 15)	118 > 70 (32, 7)	83 = 94 (22, 8)	64 = 71 (18, 16)	75 = 84 (18, 12)	79 = 65 (32, 17)
	F03	140 > 113 (29, 34)	93 = 79 (32, 26)	107 < 152 (21, 54)	55 = 52 (12, 11)	186 = 179 (49, 49)	105 = 81 (45, 32)
	F04	115 > 77 (21, 8)	88 = 97 (30, 36)	94 < 129 (13, 38)	56 = 57 (8, 6)	160 = 181 (34, 39)	101 = 116 (46, 36)
	M05	60 = 62 (14, 13)	79 = 66 (20, 5)	70 = 79 (11, 14)	56 = 59 (18, 10)	97 = 95 (5, 6)	42 = 43 (6, 9)

**Table 3**

Summary of the boundary-related temporal modifications of the constriction gestures of the IP<sub>1</sub>-final and IP<sub>2</sub>-initial words per speaker for each STRESS in the de-accented conditions. The five signs within each cell correspond to speakers, who are presented in the order of their numbering (i.e., the first sign corresponds to F01, the second to F02, etc). The signs '>', '<' and '-' stand for longer, shorter or equally long gestures between the IP and the W boundaries ( $p < 0.05$ ). Gray cells correspond to the gestures of the stressed syllable. Thick borders around cells point to the patterns observed. Solid and broken borders indicate longer and shorter IP than W gestures respectively.

C1 (m)		V1 (a)	C2 (m)		V2 (i)	C3 (m)		V3 (a)	C4 (m)		C5 (t)		C6 (ks)	
F	R		F	R		F	R		F	R	F	R	F	R
<<<<	<<<>	<<<><	>>><	>>>>	>>>>	>>>>	>>>>	>>>>	>>>>	>>>>	<<<<	>>>>	><<<	>><<
>>>>	>>>>	>>><	<>><	<>>>	>>>>	<>>>	>>>>	>>>>	>>>>	>>>>	<<<<	>>><	><<<	>>>>
>>>>	>>>>	><<<	><<<	>>>>	>>>>	<>>>	>>>>	>>>>	>>>>	>>>>	<<<<	>>>>	>>>>	>>>>

Author Manuscript

Author Manuscript

Author Manuscript

Author Manuscript



Table 4a and 4b

The planned t-test comparisons of the durations (in ms; with SD within parentheses underneath the respective durations) of the constriction gestures of the accented IP<sub>1</sub>-final words (a: C1-V3) and their subsequent IP<sub>2</sub>-initial words (b: C4-C6) across BOUNDARIES (IP vs. W) per STRESS (S1, S2, S3) for each speaker (F01, F02, F03, F04 and M05). Dark gray and light gray cells represent significantly longer (>) and shorter (<) IP than W respectively (p < 0.05)). White cells represent insignificant comparisons. Key: C = consonant, V = vowel, F = formation, R = release.

a	C1-/m/		V1-/e/	C2-/m/		V2-/f/	C3-/m/		V3-/a/	
	F	R		F	R		F	R		
S1 (stress-initial)	F01	96 < 106 (8, 7)	45 > 42 (4, 5)	134 = 138 (14, 16)	81 = 85 (7, 7)	39 = 41 (5, 8)	140 = 140 (7, 7)	76 = 72 (8, 14)	69 > 45 (17, 12)	172 = 157 (26, 22)
	F02	118 = 132 (22, 27)	74 = 79 (11, 14)	182 = 197 (26, 28)	86 = 90 (8, 13)	41 = 41 (9, 18)	155 = 149 (23, 24)	88 > 70 (10, 16)	91 > 62 (12, 16)	162 > 109 (24, 23)
	F03	114 < 124 (27, 8)	78 = 78 (6, 12)	201 = 212 (21, 18)	101 = 95 (6, 16)	55 = 52 (10, 16)	177 = 169 (18, 24)	91 > 69 (11, 7)	75 > 44 (14, 13)	157 > 120 (19, 15)
	F04	119 = 122 (13, 10)	9 = 69 (5, 6)	185 = 181 (12, 19)	98 = 97 (7, 6)	42 > 36 (5, 6)	178 > 165 (10, 9)	87 > 66 (11, 7)	95 > 47 (23, 8)	175 > 112 (40, 14)
	M05	83 = 86 (11, 13)	67 = 68 (10, 13)	174 < 186 (17, 30, ms)	72 = 77 (7, 7)	52 = 56 (8, 11)	135 = 131 (11, 8)	60 = 58 (11, 11)	100 > 86 (17, 20)	176 = 176 (20, 19)
S2 (stress-medial)	F01	82 = 80 (6, 5)	39 < 42 (5, 3)	116 < 128 (8, 12)	87 < 97 (7, 7)	44 = 53 (6, 8)	166 = 173 (15, 13)	94 < 103 (9, 10)	80 > 52 (17, 11)	184 > 159 (32, 33)
	F02	87 = 83 (17, 5)	65 = 66 (2, 7)	161 = 177 (35, 12)	104 = 111 (13, 15)	70 > 59 (10, 10)	193 = 170 (45, 51)	96 > 84 (9, 9)	92 > 45 (14, 16)	161 > 118 (40, 16)
	F03	94 = 92 (9, 4)	44 = 46 (7, 3)	140 < 159 (12, 26)	109 < 115 (11, 13)	58 = 54 (10, 10)	208 > 193 (16, 11)	120 > 89 (9, 12)	76 > 50 (19, 7)	179 > 150 (16, 29)
	F04	105 = 105 (8, 10)	46 = 45 (3, 8)	123 < 135 (11, 8)	104 = 100 (11, 9)	62 = 58 (6, 4)	231 > 207 (23, 24)	113 > 89 (8, 9)	96 > 51 (8, 14)	189 > 143 (45, 32)
	M05	66 = 67 (9, 18)	49 = 52 (8, 8)	145 = 149 (13, 15)	68 < 74 (8, 11)	66 < 74 (12, 8)	157 = 164 (12, 14)	85 = 83 (6, 8)	85 = 75 (14, 17)	197 = 193 (21, 13)
S3 (stress-final)	F01	74 = 78 (8, 7)	38 = 35 (4, 3)	94 = 98 (8, 9)	66 = 69 (6, 8)	37 = 37 (7, 4)	133 < 140 (8, 7)	81 < 88 (9, 6)	85 > 72 (11, 19)	212 > 174 (39, 25)
	F02	74 = 77 (16, 14)	51 = 54 (8, 9)	111 = 120 (19, 21)	65 = 69 (13, 18)	42 = 45 (18, 15)	163 < 169 (24, 21)	114 = 115 (22, 29)	96 > 69 (13, 12)	197 > 186 (32, 36)
	F03	78 = 79 (8, 7)	42 = 46 (6, 6)	113 < 132 (13, 21)	71 < 79 (10, 8)	51 = 51 (7, 8)	155 = 164 (10, 20)	112 = 107 (9, 8)	83 > 60 (6, 8)	193 > 158 (13, 18)
	F04	106 = 111 (9, 17)	38 = 41 (5, 5)	116 = 126 (15, 19)	71 = 73 (10, 7)	41 = 40 (5, 7)	168 = 167 (21, 12)	102 = 100 (10, 15)	104 > 65 (10, 7)	189 > 153 (27, 23)
	M05	66 = 68 (6, 10)	45 < 51 (6, 8)	115 < 126 (11, 14)	62 = 62 (9, 8)	41 = 45 (10, 8)	138 = 141 (17, 12)	77 = 78 (12, 12)	99 = 102 (14, 17)	208 = 201 (29, 13)



b		C4-/m/		C5-/t/		C6-/ks/	
		F	R	F	R	F	R
S1 (stress-initial)	F01	<b>114 &gt; 70</b> (55, 6)	<b>101 &gt; 76</b> (28, 22)	<b>78 &lt; 89</b> (13, 10)	<b>50 &gt; 38</b> (12, 9)	<b>86 &gt; 78</b> (8, 6)	<b>70 = 68</b> (10, 7)
	F02	<b>141 &gt; 72</b> (69, 11)	<b>105 = 94</b> (24, 26)	<b>92 &lt; 126</b> (26, 47)	<b>71 = 57</b> (24, 17)	<b>79 = 86</b> (15, 12)	<b>66 = 56</b> (25, 18)
	F03	<b>139 &gt; 90</b> (32, 18)	<b>80 = 86</b> (28, 32)	<b>101 &lt; 115</b> (18, 25)	<b>55 = 54</b> (8, 7)	<b>177 = 212</b> (45, 36)	<b>105 = 82</b> (45, 33)
	F04	<b>110 &gt; 64</b> (29, 17)	<b>74 = 70</b> (39, 31)	<b>99 = 105</b> (21, 20)	<b>60 = 59</b> (9, 6)	<b>180 = 179</b> (36, 33)	<b>101 = 113</b> (40, 31)
	M05	<b>65 &gt; 56</b> (13, 9)	<b>79 &gt; 63</b> (27, 7)	<b>70 = 77</b> (15, 17)	<b>59 = 59</b> (14, 8)	<b>96 = 96</b> (6, 8)	<b>44 = 40</b> (6, 7)
S2 (stress-medial)	F01	<b>113 &gt; 79</b> (31, 12)	<b>92 = 74</b> (29, 16)	<b>81 = 85</b> (14, 16)	<b>51 = 53</b> (10, 16)	<b>91 = 81</b> (18, 11)	<b>67 = 66</b> (9, 10)
	F02	<b>126 &gt; 81</b> (39, 24)	<b>102 = 116</b> (31, 30)	<b>87 = 108</b> (38, 25)	<b>66 = 64</b> (25, 14)	<b>80 &lt; 93</b> (17, 13)	<b>72 = 60</b> (24, 17)
	F03	<b>133 &gt; 91</b> (35, 28)	<b>90 = 80</b> (28, 30)	<b>110 &lt; 129</b> (25, 19)	<b>52 = 50</b> (10, 8)	<b>177 = 175</b> (52, 60)	<b>102 = 106</b> (40, 43)
	F04	<b>108 &gt; 71</b> (25, 30)	<b>77 = 78</b> (23, 33)	<b>105 = 117</b> (26, 22)	<b>58 = 59</b> (7, 5)	<b>185 = 185</b> (33, 46)	<b>84 = 87</b> (29, 38)
	M05	<b>68 = 62</b> (21, 15)	<b>69 &gt; 56</b> (20, 6)	<b>74 = 70</b> (11, 13)	<b>54 = 58</b> (11, 8)	<b>98 = 95</b> (7, 4)	<b>44 = 41</b> (7, 6)
S3 (stress-final)	F01	<b>127 &gt; 93</b> (43, 13)	<b>96 = 82</b> (28, 24)	<b>79 = 93</b> (22, 12)	<b>52 &gt; 45</b> (10, 10)	<b>89 = 84</b> (10, 10)	<b>70 = 65</b> (10, 6)
	F02	<b>138 &gt; 89</b> (47, 15)	<b>97 &gt; 70</b> (25, 7)	<b>96 = 94</b> (26, 8)	<b>58 = 71</b> (22, 16)	<b>88 = 84</b> (18, 12)	<b>66 = 65</b> (29, 17)
	F03	<b>157 &gt; 112</b> (31, 34)	<b>84 = 79</b> (30, 26)	<b>102 &lt; 152</b> (22, 54)	<b>54 = 53</b> (11, 6)	<b>172 = 176</b> (48, 49)	<b>101 = 81</b> (39, 32)
	F04	<b>113 &gt; 77</b> (18, 8)	<b>81 = 97</b> (29, 36)	<b>95 &lt; 129</b> (10, 38)	<b>59 = 57</b> (6, 6)	<b>173 = 181</b> (40, 39)	<b>103 = 116</b> (38, 36)
	M05	<b>70 = 62</b> (16, 13)	<b>70 = 66</b> (18, 5)	<b>70 = 74</b> (13, 14)	<b>57 = 59</b> (7, 19)	<b>95 = 95</b> (6, 6)	<b>44 = 43</b> (5, 9)

**Table 5**

Summary of the boundary-related temporal modifications of the constriction gestures of the IP<sub>1</sub>-final and IP<sub>2</sub>-initial words per speaker for each STRESS in each accented condition. Within each cell the rows of five signs correspond to speakers, who are presented in the order of their numbering (i.e., the first sign corresponds to F01, the second to F02, etc). Within each cell, the signs '>', '<' and '-' stand for longer, shorter or equally long gestures between the IP and the W boundaries ( $p < 0.05$ ). Gray cells correspond to the gestures of the stressed syllable. Thick borders around cells point to the patterns observed. Solid and broken borders indicate longer and shorter IP than W gestures respectively.

C1 (m)		V1 (a)	C2 (m)		V2 (i)	C3 (m)		V3 (a)	C4 (m)		C5 (t)		C6 (ks)	
F	R		F	R		F	R		F	R	F	R	F	R
<<..	>....	....<	....	...>	....	->>>	>>>>	->>>	>>>>	>....	<<<<	>....	>....	....
....	<....	<<<<	<<<<	->>>	....	<>>>	>>>>	>>>>	>>>>	....	....	....	<....	....
....	<<<<	....	....	....	<....	<....	>>>>	>>>>	>>>>	>....	<<<<	>....	....	....

**Table 6**

The mean duration (in ms) and standard deviation (within parentheses) of the constriction gestures of accented (A; only CC) and de-accented (D; pooled ND, WhQ and IR) IP<sub>1</sub>-final words per Stress. Dark gray cells correspond to longer gestures in A than in D, and light gray cell to shorter gestures in A than in D. White cells contain no significant differences between A and D.

		S1 (MAmima)		S2 (maMIma)		S3 (mamiMA)	
		A	D	A	D	A	D
C1-F	/m/	108 (20)	93 (14)	86 (15)	81 (16)	78 (18)	77 (19)
C1-R		70 (13)	65 (14)	47 (12)	47 (10)	41 (8)	43 (7)
V1	/e/	184 (32)	167 (27)	141 (25)	130 (24)	112 (19)	106 (18)
C2-F	/m/	89 (14)	82 (13)	94 (18)	84 (16)	68 (12)	63 (10)
C2-R		47 (10)	43 (13)	62 (13)	58 (12)	45 (12)	42 (12)
V2	/i/	157 (23)	146 (19)	194 (35)	177 (33)	155 (21)	144 (20)
C3-F	/m/	80 (15)	76 (18)	103 (14)	95 (16)	93 (20)	88 (19)
C3-R		86 (17)	89 (14)	85 (19)	85 (13)	96 (13)	91 (12)
V3	/e/	162 (23)	161 (25)	180 (32)	171 (26)	200 (22)	187 (26)