

COMMUNICATIONS

A RECORDING TONOMETER*

BY

D. M. MAURICE

From the Ophthalmological Research Unit, Medical Research Council, Institute of Ophthalmology, University of London

THE measurement of the resistance to outflow of the aqueous humour by the procedure of tonography has recently aroused interest in the continuous recording of the intra-ocular pressure (IOP). There are, in addition, numerous other physiological and clinical investigations which could be performed if it were possible to obtain a continuous and accurate record of the IOP in human subjects. Such recordings have been obtained using the Müller electronic tonometer connected to a suitable amplifier and recording galvanometer. This arrangement, however, suffers from several disadvantages. First, the tonometer must be held continuously on the patient's eye by an operator, and this limits the time during which the record can be continuously taken. An improvement may be effected by using a mechanical holder, such as that designed by Merté (1957), but some supervision would still be required. Secondly, the fact that it is impossible for the patient to move his head makes many experimental procedures impossible. Thirdly, the Müller instrument, being basically a Schiötz tonometer, suffers from the defects of this instrument, principally that its application to the eye raises its IOP to about double its original value (Friedenwald, 1954), the extent of the rise varying from eye to eye in a not readily determinable manner.

The instrument described in this paper is essentially a research tool and is too complicated for widespread use as a routine clinical instrument. It was designed to be mounted on the patient's forehead and to maintain its position on the eye without attention and regardless of the position of the patient's head. In addition, it seems to be intrinsically more accurate than the Schiötz tonometer. The theoretical principle on which it operates and its practical construction are first explained, and further sections describe its method of use and its performance. Only the results of investigations into normal eyes are reported in this paper; it is intended to publish studies on glaucomatous patients later. Finally, an account of the calibration of the tonometer on human cadavers is given, from which the value of the normal IOP is derived.

* Received for publication July 16, 1957.

OPERATING PRINCIPLES

This instrument measures the force necessary for a plunger to make a definite indentation into the eye. This has advantages over the customary mode of operation which measures the depth of indentation under a definite force:

- (1) Since the volume of the indentation does not change as the IOP varies, the instrument responds more rapidly and accurately to these variations. Similarly, the analysis of the changes of pressure with time in tonography will be more simple because there will be one less variable quantity.
- (2) Since the shape of the indentation does not change as the IOP varies, the relationship between indentation force and IOP should be linear.

The basic design of the instrument is shown schematically in Fig. 1. One end of the plunger P indents the cornea, and the other bears against the pressure-sensitive element R. The plunger slides in the body B, the lower part of which is formed into a conical foot F, which, near its rim, rests on the cornea.

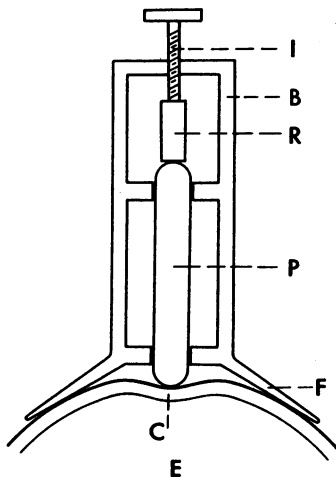

FIG. 1.—Schematic representation of recording principle.

The instrument is pressed on the cornea with a predetermined force, normally 10 g., and the plunger indents the eye to a predetermined depth, normally 0.5 mm. This 10-g. force is then divided between that required to give the plunger its indentation (0 to 8 g. according to the IOP) and the remainder (10 to 2 g.) which is supported by the foot.

There are two advantages in the rim of the foot being in contact with the cornea rather than the centre as in the Schiötz tonometer. First, it will not slip off the eyeball and will maintain its position without continuous attention. Secondly, the volume of fluid displaced by its impression is smaller. To take an example, a Schiötz tonometer with a 5.5-g. plunger weight resting on an

eye of 17 mm. Hg IOP will make contact with the cornea over the entire area of the foot-plate, 72 mm.² (Friedenwald, 1954), and will displace approximately 30 mm.³ of fluid. The total weight of the same tonometer (16.5 g.) pressing on a conical foot touching the cornea round a circle of 8 mm. diameter will make about the same area of contact but will displace only 10 mm.³ of fluid. If the weight is reduced to 10 g., only 2.5 mm.³ will be displaced.

Against these advantages must be set the disadvantage that, if the plunger is in a fixed position relative to the foot, its indentation and therefore the force acting on it will be affected by the curvature of the cornea. To eliminate this source of error, in each eye the indentation is measured from the point of contact of the plunger with the cornea. This can be effected by altering the position of R relative to B. When the instrument is first placed on the eye, R is raised so that it is not touching the plunger; it is then lowered until contact is recorded and then further to the required depth of indentation.

To permit small movements of the eyeball, the foot and plunger are mounted on a universal joint U, attached to an arm (Fig. 2). The arm is

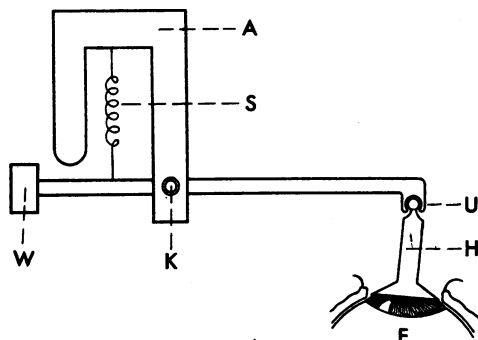
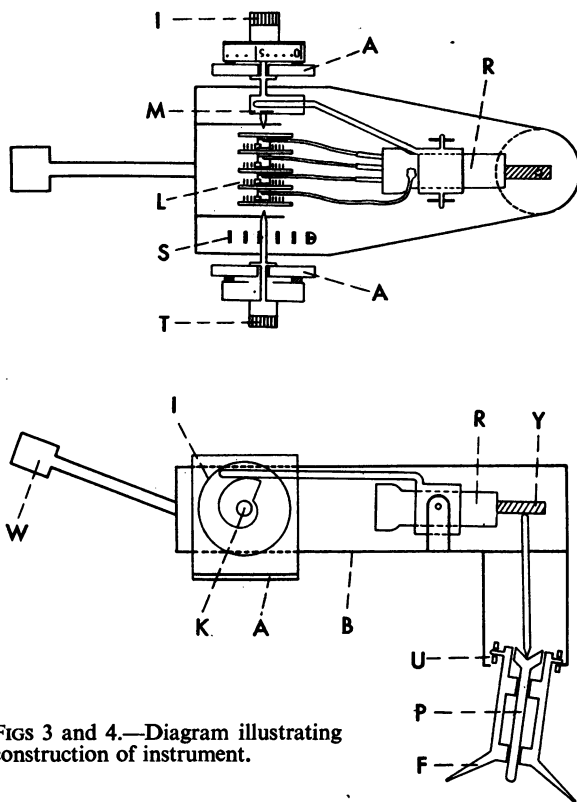

FIG. 2.—Schematic representation of tonometer mounting.

counterbalanced and pivoted in a frame A, and a spring S between the arm and the frame keeps the foot pressed on the eye. The shorter the distance between U and the cornea, the greater will be the stability with which the instrument rests on the eyeball. On the other hand, if it is too close, it is difficult to adjust the position of the foot correctly upon the cornea and small rotations of the globe will not be adequately compensated for. In preliminary tests a distance of 15 mm. was found to be a suitable compromise.

CONSTRUCTION

The construction of the instrument is shown schematically in Figs 3 and 4, and by photographs in Figs 5, 6, and 7 (overleaf). The foot F is made of transparent plastic (Perspex) and its internal conical surface is 10 mm. in diameter at its base and makes a 60° angle to the axis. A small hole is drilled through the cone near its apex to prevent it from attaching itself to the eye by suction. The plunger P is made of stainless steel tubing of 1.47 mm. external diameter. A convex spherical tip to the plunger would tend to press into the cornea at its centre and a concave or flat one at its edge. A profile of a half ellipse of axial ratio of 2 : 1 was therefore made,



FIGS 3 and 4.—Diagram illustrating construction of instrument.

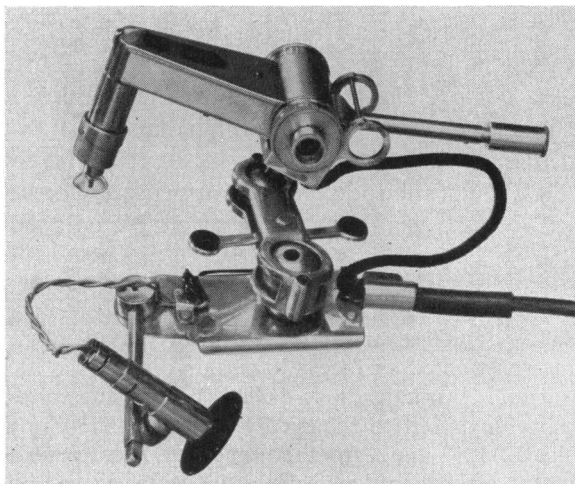

FIG. 5.—Photograph of tonometer.

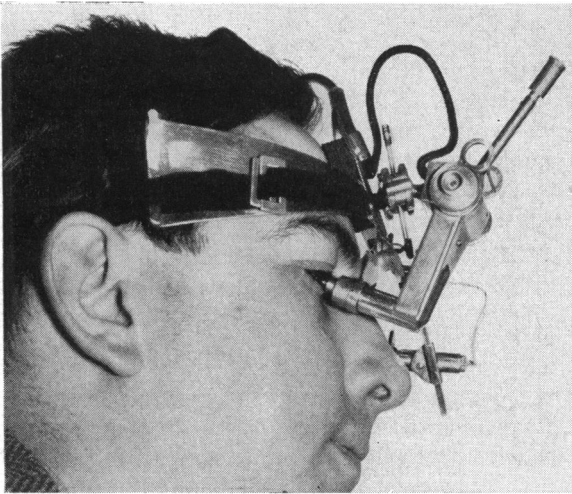

FIG. 6.—Instrument in use.

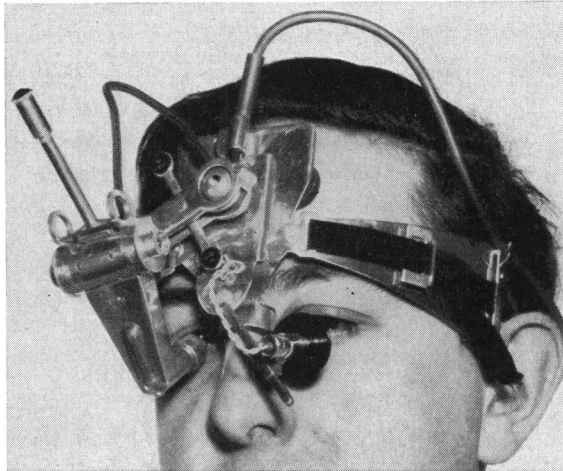

FIG. 7.—Instrument in use.

in the hope of reducing its pressure on the cornea to a low and uniform value over the area of contact. The plunger slides freely in two bearings in the foot and the space between them is filled with a light oil which lubricates the bearings and prevents tear fluid fouling them.

The foot is mounted in gimbals U, 15 mm. from the base of the cone. The plunger ends in a conical socket and its length is fixed at 13·8 mm., so that when a cornea of average radius is indented by 0·5 mm. the apex of the socket is in line with the gimbal axes. The foot and plunger may be detached together for cleaning. The socket is engaged by the pointed tip of a rod which bears against the pressure-sensitive element at its other end. A loose bearing at this end guides the rod.

To record the force on the plunger a mechano-electric transducer valve R (RCA 5734) is used as the pressure-sensitive element. This is a triode, the plate of which is connected through a flexible seal to an external stylus, so that a force applied to the stylus will slightly deflect it and change the current through the valve

proportionally. A plastic extension Y is attached to the stylus to provide a flat bearing surface for the rod.

The valve-mounting and the gimbals of the foot are attached to the body B of the instrument which is made of thin dural sheet. The body is pivoted in a frame A on two pointed steel rods which engage two bearings mounted internally in the body. These rods can be rotated by two knobs mounted on the frame and normally fixed to it by friction. The rotation of one knob T winds a flat spiral spring S attached to the rod at one end and to the body at the other, so that the foot is pressed on to the eye. The knob is connected through a slow-motion drive to a concentrically mounted dial which is calibrated in terms of the force on the foot.

The other knob I controls the plunger indentation. The transducer valve is mounted in a pivoted bracket which is rocked by means of an arm bearing against a cam M turned by the rod. In this way the stylus is moved towards the eye and presses the plunger into the cornea. The indentation scale is engraved on a ring which rotates round the knob and can be turned to bring its zero into alignment with an index mark on the body when contact with the cornea is first registered.

The electrical connexions to the valve are brought out through light spiral springs L wound round the pivotal axis of the body. The output is passed through an amplifier and led to a pen-and-ink recorder (Fig. 8). The amplifier has one stage of voltage amplification and a triode power output stage. Negative feedback is taken to the transducer from the cathode of the output stage, in order to improve the overall linearity and stability of the system. By altering the degree of feedback the sensitivity of the instrument may be changed, and three ranges are provided which may be selected with a switch. Full-scale movement of the pen on two of the ranges corresponds to an IOP of 0–80 and 0–30 mm. Hg when the indentation is 0.5 mm. The total movement on the third scale represents 8 mm. Hg, but by means of a control knob on the amplifier its zero may be adjusted to correspond to any value of the IOP so that its variations can be observed with full amplification at any level. The pen recorder writes on a 4"-wide paper strip and its response time is such that the pen can move from zero to maximum deflection in 0.1 sec. The paper

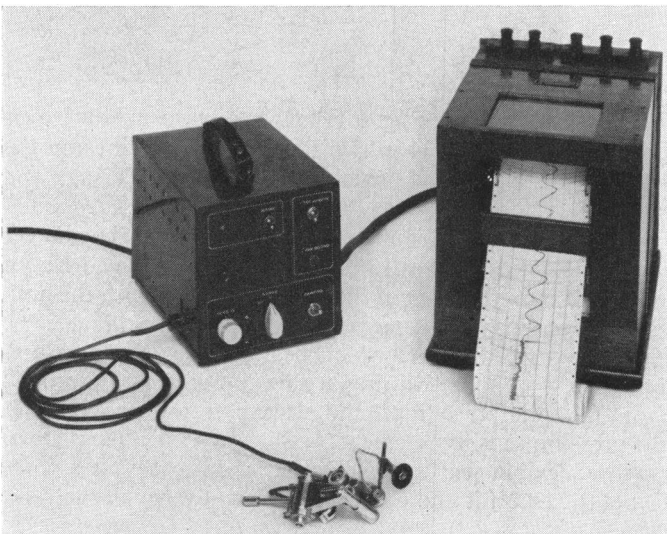

FIG. 8.—Instrument connected to amplifier and penwriter. The foot is protected by a cap.

normally moves at a speed of 1"/min., but it can be increased to 1"/sec. by pressing a push-button switch on the panel of the amplifier. Incorporated in the amplifier, also, is a switch which damps out rapid variations in the electrical response of the tonometer such as those caused by the pulse, so that the average level of the IOP may be recorded directly.

In use the instrument is mounted on a headband on the subject's forehead. The band is supported on the bridge of the nose and two points on the forehead and is held in position by an elastic strap round the back of the head. Two arms resting on the temples prevent it from rocking. A socket on the front of the headband is engaged by a plate which is connected by a double ball joint to the frame of the tonometer. The socket and plate allow the instrument to be freed from the headband while it is being adjusted or while the calibration of the instrument is being checked. The link of the double joint can be clamped by a small movement of a locking arm. When it is free the axis of the tonometer foot can be readily adjusted in all directions; when it is clamped it is locked rigidly to the headband. A fixation target is attached to an arm which is also mounted on the plate. It can be focused to suit the vision of the subject, and it is illuminated by a light, the intensity of which is adjustable by a control on the panel of the amplifier. The target is surrounded by an opaque screen to prevent other objects in the field of view distracting the subject. The weight of the complete instrument, including the headband, is 130 g. ($4\frac{1}{2}$ oz.).

A balance for checking the calibration of the tonometer has also been constructed. It has two arms, one of which balances the force on the foot and the other applies known forces to the plunger. The tonometer is attached to the balance by means of a socket similar to that on the headband. The foot fits over a plastic sphere of 8 mm. radius on the end of the first arm, and the tension of the spring is adjusted to support weights placed on the other end. A hole is drilled in the sphere through which passes a plastic rod attached to the end of the second arm. This rod pushes against the plunger with a known force when weights are placed on the pan at the other end of the arm.

METHOD OF USE

The subject lies down and the headband is fitted tightly but comfortably. The eye to be examined is well anaesthetized and a drop of parolein is instilled to lubricate the surface and reduce trauma. Fixation over considerable periods is made more comfortable if the other eye is also anaesthetized lightly. The instrument is fitted on the headband and the fixation target is focused for the far point and adjusted so that the eyes look slightly down from the primary position. The plunger of the tonometer is retracted and the spring set at 10 g. force on the foot. The instrument is gripped by the frame, the link on the ball joint is unclamped, and the foot manoeuvred under the lids. It is then adjusted until the foot appears to be centrally situated on the cornea and perpendicular to the tonometer body, and the link is then clamped. With experience it can be positioned in about a quarter of a minute without difficulty.

With the amplifier set to its most sensitive range, the plunger indentation control is turned until a deflection of the pen is noted, showing that the plunger has touched the cornea. The indentation scale is rotated until its

zero coincides with the index mark on the body and the contact point is checked; agreement to the thickness of a line on the scale, better than 0.01 mm. is generally reached. The amplifier is then switched to a less sensitive range and the indentation control knob turned to the required position. The instrument then records without further attention and the subject can make what movements he chooses provided his gaze remains fixed on the target.

If it is desired to examine the pulse wave in detail the amplifier is switched to its most sensitive range and the pen is brought to the middle of the paper with the zero control. The paper is then driven at 1"/sec. by pressing the control button.

PERFORMANCE

The instrument can be worn comfortably by most people; only two out of some hundred subjects squeezed their eyelids so much as to make its application impracticable. The foot has never been displaced by blinks and remains steadily in position when the subject rises to his feet or undertakes quite violent exercise such as "knee-bends". The instrument has remained on the eye for periods of up to 20 min. with less trauma to the eye than caused by tonography with the Schiötz tonometer, and no subsequent discomfort. The experiments are limited in practice by the difficulty in maintaining fixation over longer periods.

The force recorded by the instrument after reaching its initial level undergoes a slow decline, but it levels off at a more or less steady value after 2 to 4 min. (Fig. 9).

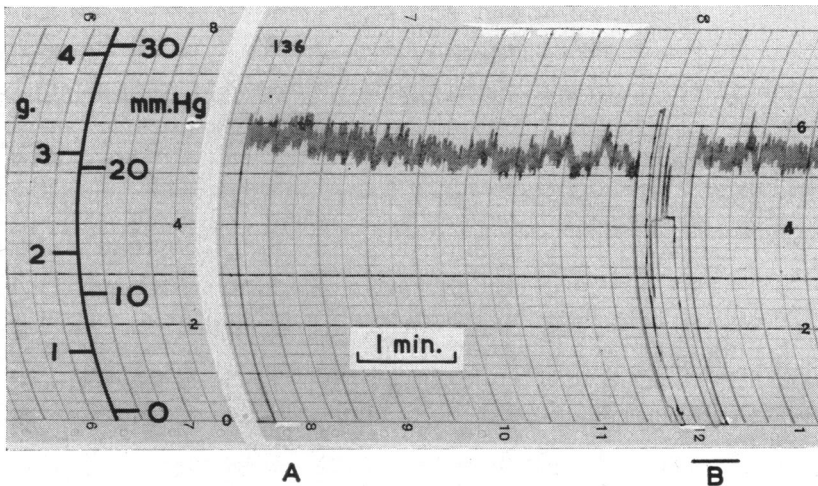

FIG. 9.—Typical tonometer recording.
A, initial plunger indentation. B, check of plunger contact and re-indentation.
The scales show the force on the plunger (g.) and the corresponding IOP (mm. Hg).

In most cases a part of this drop results from the indentation of the material of the cornea itself so that the impression of the eye is effectively less than 0.5 mm. This is made evident by checking the contact point after the steady value is reached, when it is found to have shifted by up to 0.05 mm. in eyes with a high tension but generally between 0 and 0.02 mm. in normal eyes. To avoid error in estimating the value of the IOP, the contact point was checked at the end of a recording as a routine, and the plunger reinserted by 0.5 mm. from the new position. A new level was quickly reached, and this was taken as corresponding to the correct value of the IOP.

The true tonographic drop is due to the return of the pressure to its normal value, after it has been raised by the first application of the instrument. It is measured as the difference between the reading when the cornea is initially indented by the plunger and the correct value of the IOP estimated in the way described above. The total extent of this drop—about 20 per cent. of the IOP on the average—is much smaller than that shown with the Schiötz tonometer; this corresponds to the greater rise in IOP caused by that instrument.

The IOP record shows variations about the mean level due to the pulse and other causes. The pulse wave does not show any fine detail but is generally rather flattened on the high pressure peaks (Fig. 10). The pulse amplitude appears to differ remarkably between normal subjects, a range of 5:1 being recorded. The amplitude may fluctuate in an irregular manner on an individual record, occasionally by as much as 100 per cent. No correlation between pulse amplitude and age or tonographic fall was shown.

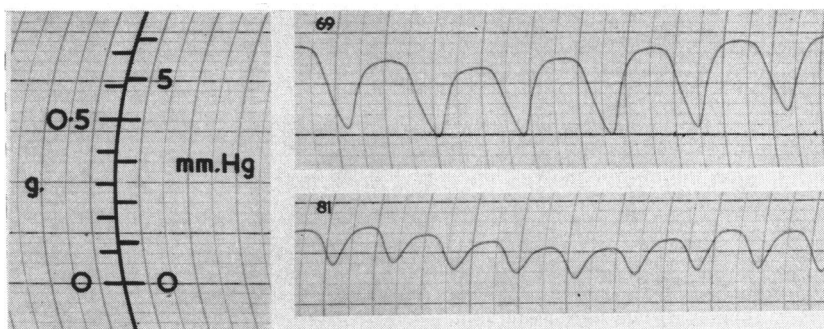

FIG. 10.—Intra-ocular pulse in two subjects. The scales show change in force on plunger and change in IOP.

1 sec.

The possibility that the observed pulse is a result of rotary or exophthalmic movement can readily be eliminated. The former can be made voluntarily during a recording and the latter may be simulated by grasping the frame of the instrument and moving it to and fro against the subject's forehead. In order to create an artificial pulse of an intermediate size, rotations of about 1° and exophthalmic movements of about 1 mm. were necessary. Movements far smaller than this would be detected subjectively or objectively if they occurred in a normal recording.

Some results showing the potentiality of the instrument as a tool in physiological research may be of interest. Fig. 11 shows the effect of forced expiration against a pressure of 5 mm. Hg in a normal subject. It is seen that the IOP rises to 150 per cent. of its normal value and that the pulse variation is suppressed. The effect of rising to the feet is shown in Fig. 12. A correction of 250 mg. has to be made for the weight of the plunger rod and stylus which is supported by the cornea when the subject is recumbent but not when he is erect. On sitting or standing there is generally a rapid rise in IOP followed by a drop below the normal value. The pressure reaches an average level which on correction is very little different from that found when recumbent: from the few cases that have been investigated there is a suggestion that there is a drop of about 1 mm. Hg.

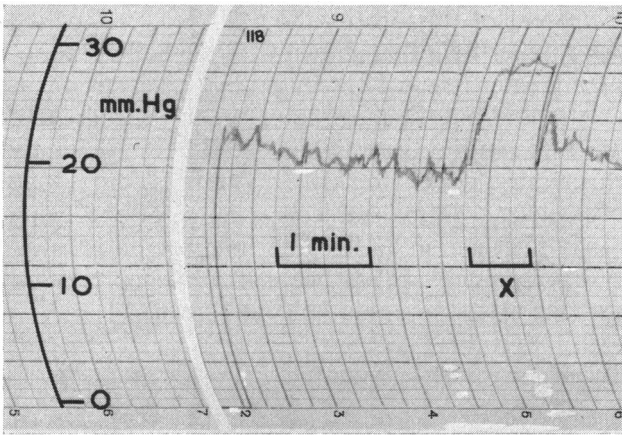
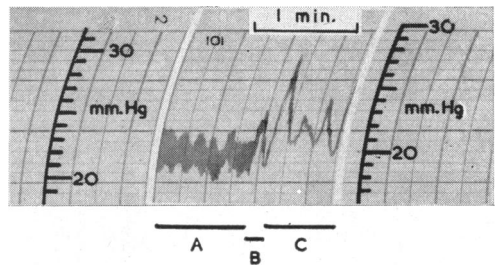

FIG. 11.—Effect of blowing (X) against a column of mercury.

FIG. 12.—Effect of rising to feet.
A, and scale left, subject lying down;
B, subject sitting up;
C, and scale right, subject rising to feet and standing.

In this subject the pulse amplitude is reduced in standing, and the amplitude of the slow rhythm is increased; some subjects show little change in the appearance of the record.



CALIBRATION

The instrument was calibrated on human cadaver eyes *in situ*. This procedure should reduce the error caused by the exaggerated distortion of the eyeball by the tonometer if it is not supported under natural conditions (Friedenwald, 1954). The eyes were cannulated and connected to a saline manometer so that a determined pressure could be developed within them. A stopcock was introduced between eye and manometer so that measurements could be made either when they were in free connexion—open stopcock measurements—or when the eye was isolated from the manometer, the

required pressure having been established within it—closed stopcock measurements. The difference between these two measurements is the rise in pressure caused by the application of the tonometer to the eye, and is determined by the rigidity of its outer tunic and the volume of the tonometer impression (Friedenwald, 1954).

It was found in preliminary trials that, when the eye was cannulated in the anterior chamber, there was a considerable difference between open and closed stopcock readings, but that this difference was almost negligible when the eye was cannulated in the vitreous body. It was observed in the former case that the anterior chamber became very deep in the course of the experiments and that it appeared unnaturally shallow in the latter. It is probable that part of the pressure in the cannulated chamber was being supported by the lens and zonule and not communicated to the other chamber. The distensibility of the dilated anterior chamber would be less than that of the eye as a whole and would thus lead to a larger rise in pressure when the stopcock was closed and the tonometer applied. It was considered that, to make the conditions as near normal as possible, both chambers should be cannulated and that they should be connected together to the stopcock through a T-junction. As a result the anterior chamber appeared to maintain its normal depth during the course of the experiments and the results fell between those obtained if each chamber was cannulated separately. Only results from eyes with double cannulation, then, were accepted for the calibration of the instrument.

To cannulate the anterior chamber, a very fine needle (0.3 mm. outside diameter) was pushed through the sclera into the posterior chamber and then directed forwards behind the iris until its point appeared in the centre of the pupil. It was connected to the manometer by a loop of very fine polythene tubing drawn down from the smallest available commercially. The end of the tubing was fitted directly over the shank of the needle which was separated from its syringe mounting. The vitreous cannula was a large-bore serum needle connected to the manometer by means of polythene tubing fitted over its shank. It was pushed squarely through the sclera at the outer canthus. Free connexion with the vitreous humour was established by aspirating about 2 ml. of it and replacing it with saline; this was made easier by drilling some small holes through the wall of the needle near its tip.

The procedure was as follows. The zero of the manometer scale was carefully levelled on the apex of the cadaver cornea by means of an arm carrying a spirit-level, and the reservoir was set to a level of 30 cm. saline. The stopcock was turned to allow a slow drip to escape and the vitreous and aqueous humours were cannulated and connected to the T junction, care being taken to avoid the introduction of air bubbles. The tonometer was mounted on the forehead of the cadaver in the normal manner and the foot adjusted on the cornea. The manometer was then set to the lowest calibration pressure, 10 or 15 cm. of saline, and the stopcock opened fully. The plunger was brought into contact with the cornea and advanced 0.5 mm. into the eye as in a normal

reading. When the output was steady the open stopcock reading was taken.

Two series of closed stopcock readings were made: one in which the rise in pressure was caused by the indentation of the plunger alone and the other by the plunger and foot together. In the first series, the foot of the instrument rested on the cornea while the eye was in open connexion with the manometer for about one minute to allow pressure equilibrium to be established. The plunger was brought into contact with the cornea, the stopcock was closed, and plunger was immediately advanced 0.5 mm. The reading usually underwent a sharp fall of undetermined cause in the first second and then a more gradual one. The closed stopcock value was taken to be that immediately after the initial fall. In the second series, the plunger was brought into contact with the cornea and then the foot was lifted off the eye for one minute with the stopcock open. The plunger was advanced 0.5 mm., the stopcock was closed, and the foot was dropped onto the eye. The maximum reading was recorded and accepted as valid if the plunger contact position was correct on checking.

Open and closed stopcock measurements of both sorts were interspersed with one another until at least three of each were obtained. The pressure in the eye was then raised and the process repeated. This was continued until a pressure of 80–90 cm. of saline was reached. A few readings were taken on the return to lower pressures but they did not differ from those taken before the eye was subjected to high pressure. At the end of each calibration the relationship between tonometer reading and plunger force was checked on the balance.

Seven eyes of six cadavers, obtained 5 to 22 hours after death, were treated in this way. They aged from 42 to 82 years at death and their case histories were free of ocular trouble. No trends with age or delay after death were found in this small sample. The open stopcock measurements, one of which is shown in Fig. 13 (opposite), all gave similar results. The points lie closely on a straight line until a pressure of 70 cm. saline (50 mm. Hg) is reached. These lines pass slightly above the origin, cutting the ordinate at a mean value for the seven eyes of 0.35 g. with a standard deviation of 0.21 g. The average slope of the lines is 0.093 g./cm. saline (0.125 g./mm. Hg) with a standard deviation of 0.0083 g./cm. saline (0.011 g./mm. Hg). The variation between the individual lines is believed to result from a real difference, of undetermined origin, between the eyes and not from instrumental uncertainties.

Above 70 cm. saline the calibration ceases to be linear, the points falling more and more below the line as the pressure rises. This is in great part because the residual force on the foot, less than 3 g. at these pressures, is insufficient to keep it in good contact with the cornea. When the tension on the control spring was raised to a value of 15 to 20 g., the experimental points obtained at high pressures fell closer to the straight line but lay below it still. The cause of the residual non-linearity is the flexibility of the stylus of the transducer valve. Under the maximum force encountered in the calibration,

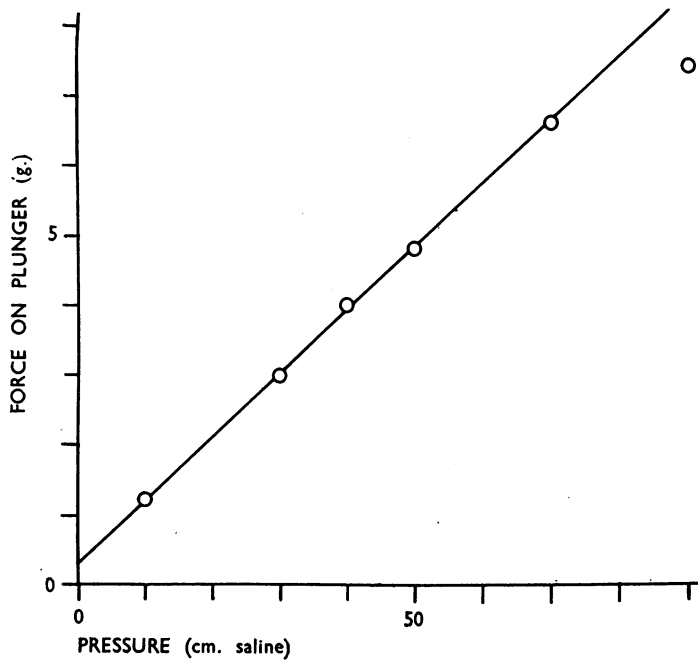

FIG. 13.—Open stopcock calibration. Points from one eye.

8 g., the tip of the stylus may be calculated to deviate by almost 0.05 mm. Accordingly, the indentation of the cornea by the plunger at high pressures will be reduced by this amount, almost 10 per cent of its nominal value.

The closed stopcock measurements were invariably higher than the open. Fig. 14 shows the average and range of the difference between their values.

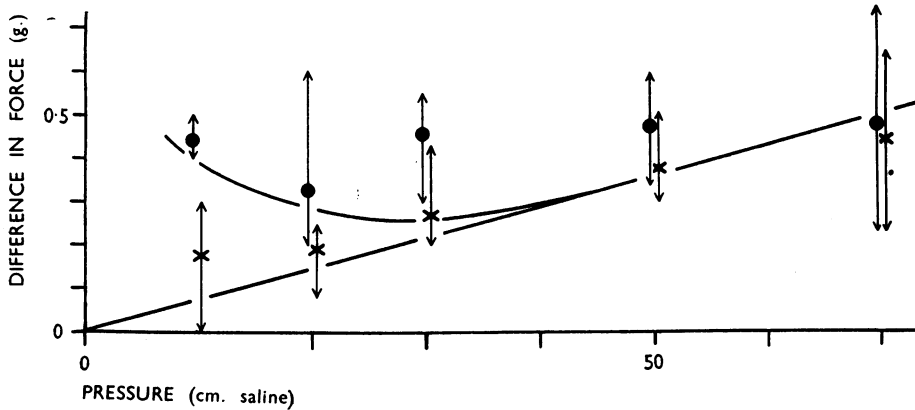

FIG. 14.—Closed stopcock calibration. Mean values and ranges from five to seven eyes.
 Abscissa: Pressure in eye before indentation, P_0 .
 Ordinate: Difference in force on plunger between closed and open stopcock measurements.
 Circles: Indentation by foot and plunger together.
 Crosses: Indentation by plunger alone.
 Curves derived theoretically as explained in text.

It will be seen that this difference remains nearly constant at 0.5 g. whatever the IOP when the indentation of foot and plunger together is considered. The fraction due to the plunger increases as the IOP rises and virtually accounts for all the difference between the open and closed stopcock readings at higher pressures.

It is possible to find a quantitative theoretical basis for the experimental values of the open and closed stopcock readings. The relation put forward by Friedenwald (1954) for the increase in IOP when the eye is indented by a tonometer will be assumed. When the indentation volume V_T is very small this takes the simple form:

$$P_T - P_o = KV_T P_o \quad (1)$$

where P_o and P_T represent the intra-ocular pressure before and after the application of the tonometer and K is a constant. From Friedenwald's determinations, K is $0.0215 \times \log_e 10$, or 0.05 per mm.³. It is assumed that the plunger gives a constant indentation, V_T , so that the rise in pressure will be proportional to the pressure in the eye itself. The straight line in Fig. 14 was drawn to give the best fit to the points and corresponds to a value of 1.5 mm.³ for V_T ; this value is quite consistent with an indentation depth of 0.5 mm., but it is difficult to calculate the relationship exactly.

The indentation by the tonometer foot V_F can be calculated to be:

$$V_F = \frac{2}{\pi^{2/3} \sqrt{3}} \left(\frac{F}{R P_T} \right)^3 \quad (2)$$

where F is the force pushing the foot on the eye and R is radius of the cornea. F must be put equal to 10 g. less the force on the plunger derived from the open stopcock calibration. From these equations it is possible to calculate the total indentation V_T , at any value of P_o . Actual values are 8.5 mm.³ at 10, 3.0 mm.³ at 20, and 1.8 mm.³ at 30 cm. saline.

The total rise in pressure caused by the tonometer, derived from Equation 1, is shown as the upper curve in Fig. 14. Its approximate agreement with the experimental points lends support to this theoretical interpretation.

NORMAL VALUES

Recordings have been taken of the IOP of a number of normal subjects lying supine. They were made between the hours of 10 a.m. and 4 p.m. Generally each record lasted for 5 or 6 minutes. A readjustment of the plunger indentation was made before the final minute of the recording. The majority of tracings show rhythmic variations superimposed on a more or less steady IOP, the level of which can be estimated to 0.5 mm. Hg without trouble. In a few cases the IOP apparently drifted by 2 or even 3 mm. Hg in the final period and there is a corresponding uncertainty in assigning it a value. The mean value of the pressures from 22 subjects estimated in this way was 19 mm. Hg, with a standard deviation of 3 and extremes of 15 and 26 mm. Hg.

It should be noted that these levels are measured at a time when the IOP has returned to normal after being raised by the application of the instrument. Unlike determinations made with the Schiötz tonometer they are independent of the distensibility of the eye. The conditions were comparable with those of the open stopcock calibrations except that there may have been differences in the flexibility of the cornea as a result of *post-mortem* swelling.

The total tonographic drop was measured as the difference between the value at the first indentation of the plunger and the final level achieved after the depth of indentation was checked. It had a mean value of 3.5 mm. Hg and a range of 1–8 mm. Hg. This drop might be expected to be similar to the difference of the open and closed stopcock readings if the living and dead eyes had the same distensibility. Normally the foot is resting on the subject's eye for about one minute before the plunger indents it. The appropriate closed stopcock value, therefore, should be somewhere between that corresponding to the application of the whole instrument to the eye and the indentation of the plunger alone. The average differences between the open and closed stopcock readings at a mean pressure of 19 mm. Hg are 4 and 2.5 mm. Hg in the two cases, in fair agreement with the tonographic drop. The range is much smaller, but since only seven cadaver eyes were tested it is of little significance.

As was stated previously the pulse pressure amplitude varies greatly from eye to eye and is not constant for one eye during a recording. A rough value can be assigned in each case however and in this sample of eyes, the peak to peak amplitude varied from 0.5 to 2.5 mm. Hg (mean 1.5 mm. Hg).

I wish to thank Mr. C. J. Downing for constructing this instrument, and Mr. F. Sheen for making a prototype. Mr. W. E. S. Bain kindly assisted with the calibration and the recordings.

REFERENCES

- FRIEDENWALD, J. S. (1954). "Standardization of Tonometers: Decennial Report by the Committee on Standardization of Tonometers". American Academy of Ophthalmology and Otolaryngology.
- MERTÉ, H.-J. (1957). *Ophthalmologica (Basel)*, 133, 134.