

ELECTROCHEMICAL CHANGES ASSOCIATED WITH THE FORMATION OF THE AQUEOUS HUMOUR*

BY

D. F. COLE

Ophthalmological Research Unit (Medical Research Council), Institute of Ophthalmology, University of London

If it is granted that the aqueous humour is formed by the active transfer of solutes and solvent from the plasma to the aqueous, it follows that the rates of transfer of the various solvent or solute species and the steady-state composition of the aqueous will depend upon the electrochemical potential difference (P.D.) across its boundaries with the plasma. Alterations of the electrochemical P.D. should modify the transfer processes from blood to aqueous and, conversely, metabolic inhibitors which affect aqueous humour formation are likely to alter the electrochemical P.D. Thus, the electrochemical P.D. between two solutions in a common solvent separated by a membrane is:

$$\Delta\bar{\mu}_j = RT \cdot \ln \frac{(a_o)}{(a_i)} + zF.E,$$

where $\Delta\bar{\mu}_j$ is the electrochemical P.D. of the j th ion, R the gas constant, T the absolute temperature, a_o the chemical activity of j in the outside solution, a_i the chemical activity of j in the inside solution, z the valency of the ion, F Faraday's number, and E the electrical P.D. between the two solutions. The passive flux ratio (M_{in}/M_{out}) for a given ion is related to the electrochemical P.D. of the ion across the membrane by the expression:

$$RT \cdot \ln(M_{in}/M_{out}) = \Delta\bar{\mu}_j$$

where M_{in} is the inward and M_{out} the outward flux of the j th ion in $\mu\text{M}/\text{min}$. (Ussing, 1949, 1960). Both these equations contain either implicitly or explicitly an expression for the electrical P.D. across the membrane, in this case the blood-aqueous barrier.

The object of the present work has been to make some preliminary studies of the electrical phenomena associated with aqueous humour formation and in particular:

- (a) the action of metabolic inhibitors on aqueous flow and blood-aqueous P.D.
- (b) the electric current flow across the blood-aqueous barrier at zero P.D. (Ussing and Zerahn, 1951)
- (c) the action of an imposed electromotive force (E.M.F.) from an external source upon aqueous flow.

Technique

Collection of Effluent.—Using a technique described in an earlier publication (Cole, 1960b), aqueous humour was collected continuously under a

* Received for publication July 5, 1960.

pressure of 20 mm. Hg from eyes in which the drainage channels had been obstructed.

Blood-Aqueous P.D.—The P.D. was measured between two electrodes, the one inserted in the marginal ear vein and the other with its tip situated in the posterior chamber of the eye. Both electrodes were made from glass tubes with an outside diameter of 2.5 mm. drawn down at one end to a fine point of about 0.1 mm. O.D. These electrodes were filled with 1 per cent. agar in 0.9 per cent. saline and were stored in 0.9 per cent. saline before use. Contact between the capillary electrodes and calomel electrodes was established by means of 12 to 18 in. of flexible "Portex" tubing (Portland Plastics Ltd., Hythe, Kent) containing 3M potassium chloride, and the overall resistance of each electrode was of the order of 100 K Ω . Potentials were measured with a Model 33B "Vibron" Electrometer (Electronic Instruments Ltd., Richmond, Surrey, England), the output of which was fed to a pen-recorder (Millimeter Recorder, 5G/284 Type A, Evershed and Vignoles Ltd., Chiswick, London) through a simple transistor amplifier. The input impedance of the "Vibron" Electrometer was 10¹³ Ω .

Considerable care was necessary to insert the electrode into the posterior chamber. The glass capillary was coated with a thin layer of Vaseline down to 3 mm. from the tip. With the eye proptosed the superior rectus muscle was grasped with fixation forceps in the left hand whilst the point of the capillary was pressed with the right hand against the sclera just behind the limbus and close to the insertion of the rectus muscle. By increasing the pressure with the right hand and rotating the electrode about its long axis the tip usually penetrated the sclera without undue difficulty. The rectus muscle was then freed and the weight of the electrode and "Portex" tubing supported on a piece of cotton wool placed close to the animal's head. A 1 cm. square of thin polythene sheeting was gently inserted between the shank of the capillary and the sclera and a dab of Vaseline applied at the point where the sclera was penetrated. The indifferent electrode had already been placed in the ear vein and measurement of the blood-aqueous P.D. could be commenced immediately. When the procedure had been carried out satisfactorily, a P.D. of 5–10 mV was usually obtained (aqueous positive to blood) without undue drift or "noise". The use of Vaseline seemed to reduce the incidence of drift or other disturbances, presumably by preventing electrical leakage along the site of entry of the capillary. In some instances slight eye movements caused rapid changes of potential and occasionally there were slow oscillations of less than 0.2 mV, in phase with the animal's respiratory movements.

The chief difficulties encountered were fracture of the capillary during insertion or subsequent haemorrhage into the aqueous. Fortunately neither of these mishaps could pass undetected and experiments in which

they occurred were abandoned. In all experiments the electrode capillary was placed in the posterior chamber before inserting the collecting needle through the cornea.

Short-circuit Current.—Current was passed between an electrode placed on the cornea after scratching the epithelium, and a second electrode usually placed in a leg vein or the rectum.

The arrangement is shown diagrammatically in Fig. 1. The first electrode (D) made contact with the eye *via* a small polythene cylinder (C) containing electrocardiograph electrode paste and placed on the cornea. One of the electrodes (E) for recording the blood-aqueous P.D. was placed in the posterior chamber as already described, the other was situated in the marginal

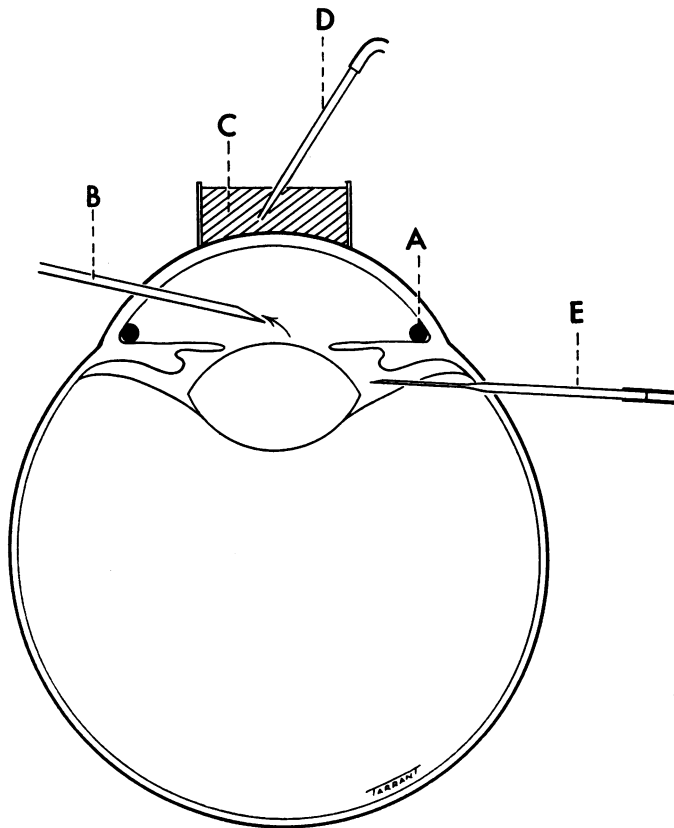

FIG. 1.—Diagrammatic transverse section of eye showing positions of collecting needles and electrodes.

A = Silicone fluid MS/200/20 (Hopkin & Williams Ltd., London, England) obstructing drainage angle.

B = Effluent needle to collecting system.

C = Polythene cylinder containing electrode paste situated on cornea.

D = Current-measuring electrode (corresponding to X in Fig. 2).

E = Potential-measuring electrode in posterior chamber (corresponding to A in Fig. 2).

ear vein and both were connected to the "Vibron" electrometer as before. The current-measuring electrodes were constructed on the same principles as those used for the potential measurements, except that the tips were considerably wider. They were connected to calomel electrodes by means of 3M potassium chloride bridges. Current was obtained from a small dry cell through a potential divider, and a reversing switch and was measured with a moving-coil micro-ammeter (F.S.D. $150 \mu\text{A}$, 5" scale) in series with the electrodes.

Before attempting any current measurements, a steady value for the blood-aqueous P.D. was obtained. After this the P.D. was determined for a series of steady currents, ranging from $+140$ to $-140 \mu\text{A}$ at intervals of $20 \mu\text{A}$. Over this range the current-voltage relationship was linear.

Calculation.—Fig. 2 may be taken as a simplified equivalent circuit, with A and B representing the millivoltmeter electrodes, and X and Y the current

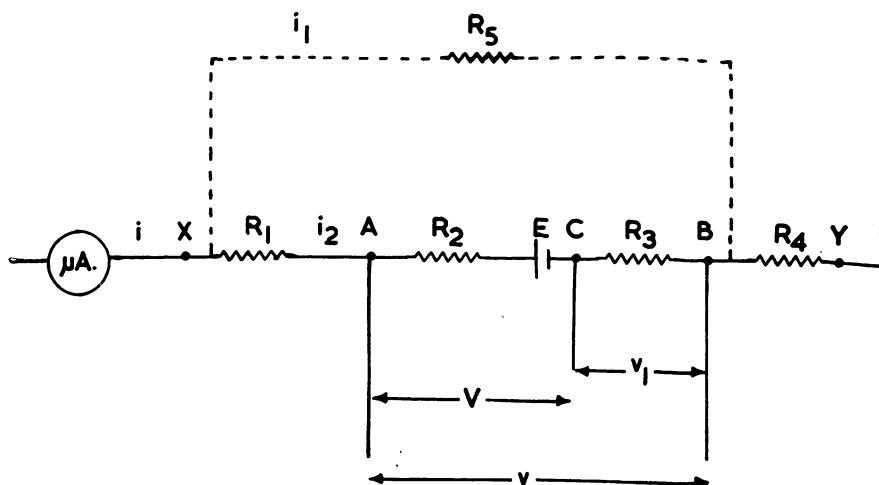

FIG. 2.—Equivalent electrical circuit illustrating method of calculating short-circuit current.

- μA Micro-ammeter measuring current in external circuit ($=i \mu\text{A}$) which passes between corneal electrode (X) and second current electrode (Y).
- R_1 Corneal resistance ($=r_1$ ohms).
- A and B Potential-measuring electrodes connected to millivoltmeter.
- R_2 Resistance of blood-aqueous barrier ($=r_2$ ohms).
- E Source of electromotive force (E.M.F.) in blood-aqueous barrier.
- R_3 Resistance between uveal vessels and potential electrode, B, situated in ear vein ($=r_3$ ohms).
- R_4 Resistance between ear vein and second current electrode ($=r_4$ ohms).
- R_5 Resistance of "extra-ocular shunt" ($=r_5$ ohms), carrying current radially through corneal stroma from electrode X to limbus.
- i_1 Current flowing through "extra-ocular shunt".
- i_2 Current passing through blood-aqueous barrier.

Where current is flowing there will be a P.D. across R_3 and hence the measured P.D. between A and B ($=v$ mV) will be equal to the sum of the P.D. across the blood-aqueous barrier, i.e. between A and C ($=V$ mV), and the P.D. across R_3 ($=V_1$ mV). It will be seen that $V=v-v_1$, and that $v_1=i_2r_3$. Therefore, if i_2r_3 and v are known, V may be calculated.

electrodes. The recorded P.D. may be represented by v and the corresponding current by i .

R_1 represents corneal resistance ($=r_1$ ohms)

R_2 represents resistance of blood-aqueous barrier ($=r_2$ ohms)

R_3 represents resistance between uveal vessels and ear vein ($=r_3$ ohms)

R_4 represents resistance between ear vein and second current electrode ($=r_4$ ohms)

E represents a source of electromotive force (E.M.F.) in the blood-aqueous barrier

V represents the blood-aqueous P.D. ($=V$ mV)

It will be seen at once that where no external current applied (*i.e.* where $i=0$), the measured P.D. ($=v$ mV) is equal to V . Where current flows through the system, a P.D. exists across R_3 so that the measured P.D. is greater than V by an amount v_1 . The short-circuit current is the value of i for which $V=0$. This was calculated indirectly as follows.

After the experiment was ended the resistance between the uveal blood and the ear vein (R_3) was determined directly, using a 2.9 Kc/s bridge (Mullard E 7566). The cornea was excised, the lens and vitreous removed, and the integrity of the barrier between the blood and the contents of the globe disrupted mechanically. Blood flowed freely into the globe and the resistance between this and the ear vein was measured, using platinized platinum electrodes. In some cases the resistance was also measured with one electrode in the orbital venous sinus; these values did not differ from those obtained with the electrode in the globe. Values for r_3 ranged from 180 to 280 ohms in different animals. From Fig. 2 it may be seen that $V=v-v_1$ and, assuming that Ohm's Law operated, $v_1=ir_3$ and

$$V=v-ir_3$$

From this equation a series of points for V at different values of i and v were calculated, assuming r_3 to remain constant. These points fell on a straight line which was extrapolated to $V=0$. The corresponding value of i for $V=0$ is, by definition, the short-circuit current. The slope of the graph obtained by plotting i against v , *i.e.* di/dv , gave estimates of r_2+r_3 which were between 6 and 13 per cent. greater than the figures obtained for r_3 .

A slightly better approximation may be obtained by allowing for current flowing radially through the cornea to the limbus, resulting in an "extra-ocular shunt" (R_5 in Fig. 2). Current flowing through the corneal stroma must be carried largely by sodium and chloride which are the most abundant ions. The stromal resistance to diffusion of Na^+ is approximately four times the resistance in free solution (Maurice, 1951) and, assuming a corneal radius of 0.2 cm. and a thickness of 0.036 cm. (Maurice, 1951), calculation of a value for r_5 shows that the current passing through the eye (i_2 in Fig. 2) is approximately ten times the current flowing through the "extra-ocular shunt" (i_1) and hence about 91 per cent. of the value shown on the microammeter. Direct measurement of r_5 with a 2.9 Kc/s bridge gave values of about 3,000 ohms, some 50 per cent. greater than the calculated value.

This correction was incorporated in the estimated short-circuit current. However, the greater error probably lay in the assumption of uniform distribution of current density throughout the blood-aqueous and blood-vitreous barriers. Nevertheless, despite these difficulties, the observed changes of short-circuit current were consistent with the directly measured alterations of net sodium influx.

Imposed Electrical Potential.—In some experiments the inflow rates of sodium and water were measured whilst an external E.M.F. was applied across the eye. The apparatus used in these experiments was the same as that used for the measurement of short-circuit current, and the blood-aqueous P.D. could be varied between -50 and $+50$ mV. A constant E.M.F. was applied for periods of 15 to 30 minutes, but with positive values there was often a slow downwards drift which was compensated by manual adjustment of the potential divider. When the external E.M.F. was disconnected the blood-aqueous P.D. returned to its initial value.

Chemical Methods.—The methods for estimating sodium in the effluent fluid and for calculating the water and sodium influx have been described in detail in an earlier report (Cole, 1960b).

Experimental Material.—In nearly all cases adult albino rabbits (2 to 2.5 kg. body weight) were used, but a few experiments were carried out with pigmented rabbits. All were fed on Diet 18 ("Blue Cross" Animals Food-stuffs, Associated London Flour Millers Ltd.) and allowed free access to water. They were anaesthetized with intravenous urethane (7 to 8 ml./kg. body weight 25 per cent. w/v solution in physiological saline). 1 per cent. amethocaine B.P. was instilled into the eye before inserting the collecting needle or the capillary electrode. Where metabolic inhibitors were administered a polythene cannula was inserted into the lingual artery on one side (Cole, 1959), with the exception of some experiments using azide in which the inhibitor was given intravenously. Where both azide and another inhibitor were used, the azide was given intravenously and the other inhibitor *via* the lingual artery.

Strophanthin-G ($C_{30}H_{46}O_{12} \cdot 9H_2O$)—Strophanthin-G was dissolved in buffered isotonic saline (pH 7.4) to give a concentration of 4.0 mM/L. and infused at rates between 0.02 and 0.05 μ M/min.

2:4-dinitrophenol (DNP)—A 20-mM solution in buffered isotonic saline was infused at 0.0009–0.0012 mM/min.

Monoiodoacetic Acid (MIA)—A 40-mM solution in buffered isotonic saline was infused at rates between 0.002 and 0.006 mM/min.

Sodium Azide—A 1.5 per cent. w/v in buffered isotonic saline was given intravenously at 1.5 mg./min. For infusion *via* the lingual artery a 20-mM solution was administered at between 0.0010 and 0.0015 mM/min.

Results

Control values for nett sodium and water influx, blood-aqueous P.D., and short-circuit current are shown in Table I, together with the changes resulting from administration of metabolic inhibitors.

TABLE I
EFFECTS OF INHIBITORS UPON WATER AND SODIUM INFLUX AND
BLOOD-AQUEOUS POTENTIAL DIFFERENCE

Mean Values \pm S.E.M.

Series	Potential Difference		Inflow		Na Influx		Short-Circuit Current	
	Before Treatment (mV)	Change (mV)	Before Treatment (μ l./min.)	Change (μ l./min.)	Before Treatment (μ Eq/min.)	Change (μ Eq/min.)	Change (μ A)	Control Series (μ A)
Control	6.59 \pm 0.51	—	6.09 \pm 0.61	—	0.886 \pm 0.13	—	—	435 \pm 67
DNP	6.44 \pm 0.27	-3.9 \pm 0.29	6.75 \pm 1.0	-2.67 \pm 0.26	0.924 \pm 0.11	-0.378 \pm 0.10	-296	—
Strophanthin G	6.10 \pm 0.36	-4.4 \pm 0.23	5.71 \pm 0.50	-3.56 \pm 0.54	0.854 \pm 0.08	-0.532 \pm 0.09	-350	—
Azide	6.22 \pm 0.80	+7.75 \pm 1.65	5.57 \pm 0.71	+3.79 \pm 0.31	0.850 \pm 0.11	+0.686 \pm 0.17	+265*	—
MIA	5.65 \pm 0.71	-4.8 \pm 0.70	6.54 \pm 1.1	+5.20 \pm 0.61	0.918 \pm 0.17	+0.870 \pm 0.27	-236	—

* These results were obtained using only three animals.

Fig. 3 and Fig. 4 (opposite) show typical records of the falls in blood-aqueous P.D. caused by strophanthin-G and MIA respectively.

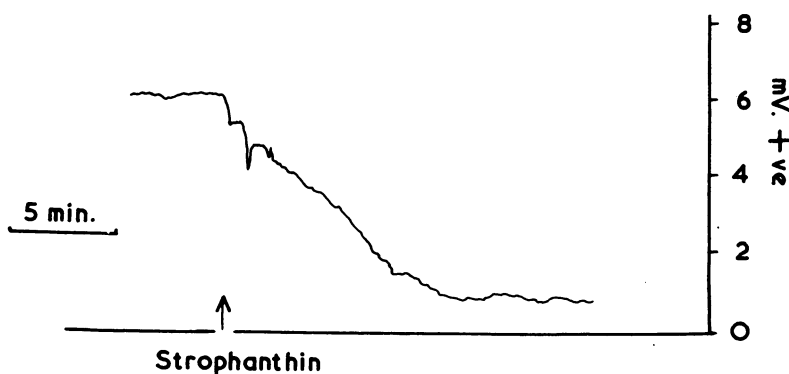

FIG. 3.—Recording of blood-aqueous P.D. during administration of strophanthin-G (0.05μ M/min.) *via* the lingual artery.

Arrow marks start of infusion of strophanthin-G.

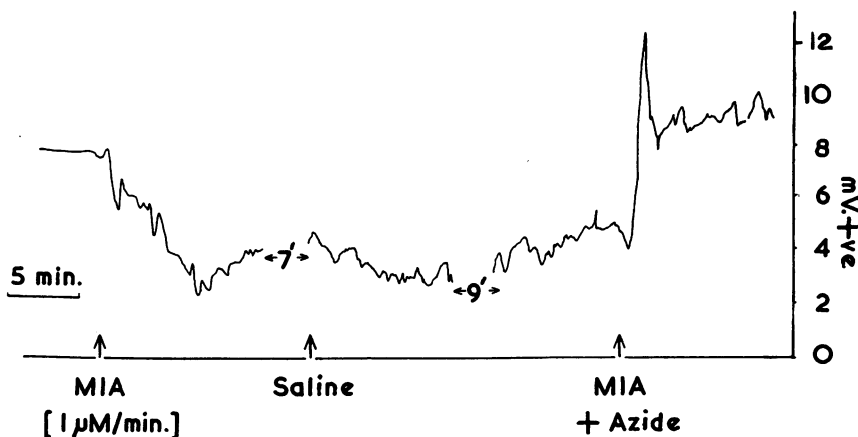

FIG. 4.—Recording of blood-aqueous P.D. during administration of monoiodoacetic acid (0.004 mM/min.) *via* the lingual artery and of sodium azide (1.5 mg./min.) intravenously. MIA alone reduces P.D., but does not prevent increase of potential after administration of azide.

A typical record of the action of DNP is shown on the left-hand side of Fig. 5.

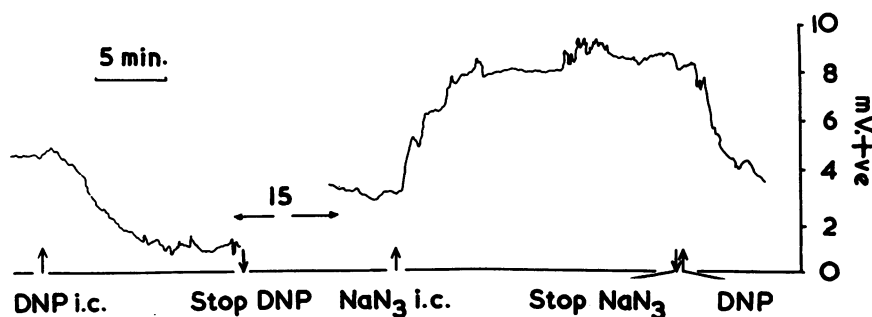

FIG. 5.—Recording of blood-aqueous P.D. during administration of dinitrophenol (0.0012 mM/min.) and sodium azide (0.0015 mM/min.) *via* the lingual artery.

DNP reduces the potential but there is partial recovery when it is stopped. Subsequently, azide causes a marked increase of potential which is abolished by resuming the administration of DNP.

The result of an experiment showing the action of azide given *via* the lingual artery is shown in Fig. 6 (overleaf). This experiment was performed on a dark-adapted eye; light flashes (0.10 lamberts 0.1 sec.) were used as stimuli before and after azide administration. The record shows greatly exaggerated *c*-waves of the electroretinogram in the presence of azide (Noell, 1953, 1954). Intravenous azide appeared equally effective in raising the steady blood-aqueous P.D. (Fig. 7, overleaf). Fig. 4 shows, in addition to the action of MIA alone, the failure of this agent to prevent the rise of P.D. caused by azide. In contrast, Fig. 5 shows an experiment where, after recovery from DNP treatment, azide caused a marked increase of P.D. which was promptly reduced by a second administration of DNP.

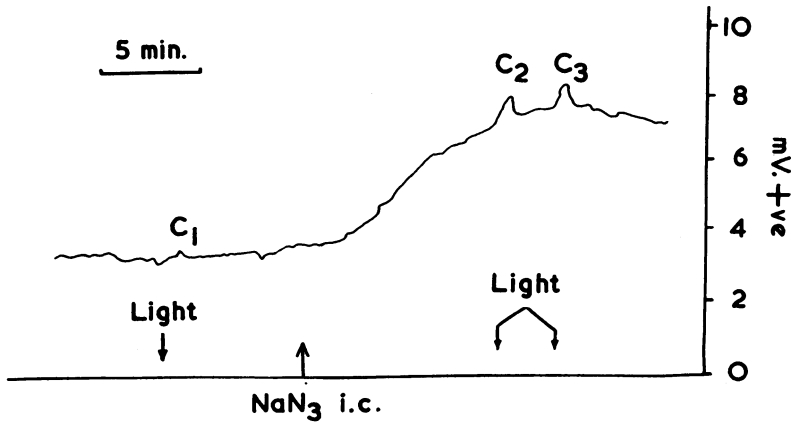

FIG. 6.—Recording of blood-aqueous P.D. during administration of sodium azide (0.0010 mM/min.) *via* the lingual artery.

c_1 represents the *c*-wave of the electroretinogram in response to a light flash (0.1 sec. at 0.10 lamberts) before giving azide; c_2 and c_3 represent the *c*-waves in response to similar stimuli during administration of azide.

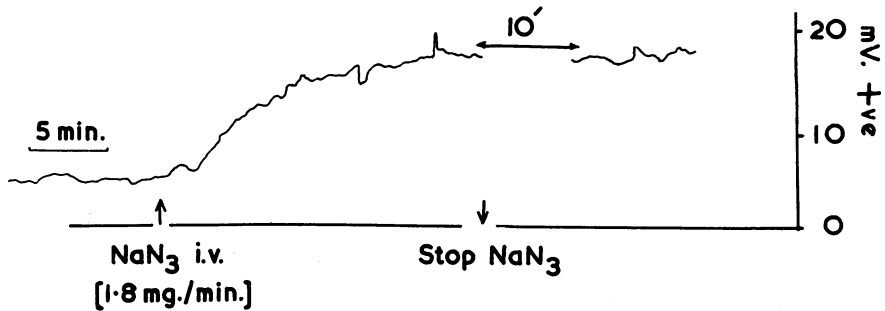

FIG. 7.—Recording of blood-aqueous P.D. during administration of azide (1.8 mg./min.) intravenously.

Arrows mark start and finish of azide injection.

Table II shows the results of an imposed external E.M.F. upon the inflow rates of sodium and water. The values for change in current represent the

TABLE II
EFFECTS OF IMPOSED EXTERNAL ELECTROMOTIVE FORCE UPON WATER
AND SODIUM INFLUX INTO THE AQUEOUS HUMOUR
Mean values \pm S.E.M.

Influx				Change in Blood-aqueous Potential Difference (mV)	Current in External Circuit (μ A)	Orientation of Proposed E.M.F.
Control Period		Change				
Sodium (μ Eq/min.)	Water (μ l./min.)	Sodium (μ Eq/min.)	Water (μ l./min.)			
0.926 ± 0.15	5.92 ± 0.51	-0.435 ± 0.10	-1.60 ± 0.30	(range) -40 to -70	(range) -150 to -250	Opposing Natural P.D.
0.940 ± 0.11	5.75 ± 0.37	+0.245 ± 0.07	+1.30 ± 0.12	(range) +46 to +90	(range) +100 to +290	Enhancing Natural P.D.

current measured in the external circuit and the true values for the change in current across the blood-aqueous barrier would be subject to correction factors similar to those discussed for the measurement of short-circuit current, and hence the figures for change in sodium influx (if expressed in μA) are greater than the changes in current measured in the external circuit. Nevertheless, a consistent relationship between change in blood-aqueous P.D. and sodium influx may be discerned. Where the applied E.M.F. caused the aqueous to become electrically negative to plasma, the sodium concentration of the effluent aqueous humour was decreased (Fig. 8).

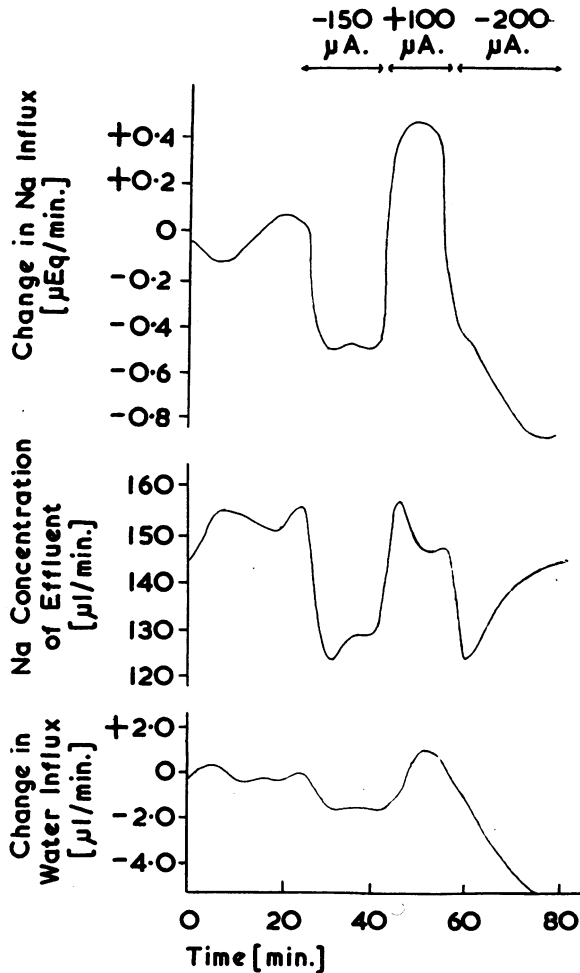

FIG. 8.—Changes in sodium and water influx and in sodium concentration in effluent aqueous humour during imposition of EMF from an external source. Arrows show duration of imposed EMF and value of the current measured in external circuit. Positive current values enhance the naturally occurring P.D. and negative values oppose it.

Discussion

The control values for sodium and water influx agree with those reported previously, and it is reasonable to assume that (of the total sodium influx of 0.886 $\mu\text{Eq}/\text{min}.$) some 0.3 $\mu\text{Eq}/\text{min}.$ represents the fraction of influx not subject to inhibition by DNP (Cole, 1960b). On this view, active transport across the blood-aqueous barrier in these experiments would have amounted to 0.58–0.60 $\mu\text{Eq}/\text{min}.$

Values for blood-aqueous P.D. agreed well with the results of Lehmann and Meesmann (1924) and Fischer (1932), and with the more recent findings of Berggren (1960). The variation from one animal to another was considerable, but in any one animal reasonably steady readings were usually obtainable for up to one hour from the start of the recording.

The "short-circuit current" (Ussing and Zerahn, 1951; Ussing and Andersen, 1956) was calculated in the manner described above. Since it was not possible to ascertain the current distribution within the eye with respect to the blood-aqueous barrier and the intra-ocular electrode, these estimates should not be regarded as more than approximate indications of the true short-circuit current. The mean value of the short-circuit current, 435 μA , corresponds to a nett sodium influx of 0.3 $\mu\text{Eq}/\text{min}.$, about 50 per cent. of the value obtained by chemical analysis of the effluent fluid. However, it will be seen in Table I that changes in short-circuit current correspond in direction, if not always in magnitude, with alterations in the sodium influx.

DNP, Strophanthin-G.—The effects of DNP upon influx agreed with earlier findings (Cole, 1960a,b). The reduced influx of sodium and water was associated with falls in blood-aqueous P.D. and short-circuit current. These results resemble the findings of Fuhrman (1952), Schoffeniels (1955), and Koefoed-Johnsen (1957) on frog skin. The rapid fall in P.D. after administration shows that inhibition commences as soon as the toxic agent reaches the blood-aqueous barrier.

The action of strophanthin-G resembled closely that described in other tissues (Solomon, Gill, and Gold, 1956; Koefoed-Johnsen, 1957; Solomon, 1959; Carey, Conway, and Kernan, 1959), an action which Ussing (1959; 1960) associates with potassium-sodium exchange. Expressed in terms of molar concentration, strophanthin-G was a more potent inhibitor than either DNP or fluoracetamide (Cole, 1960a,b), a fact which is a strong indication for the participation of a sodium-pump mechanism in the production of aqueous.

For the reasons already discussed, the decrease in short-circuit current (by 296 μA with DNP and by 350 μA with strophanthin) in neither case amounted to more than about 50 per cent. of the decrease in nett sodium influx.

Azide, MIA.—Both these agents significantly increased sodium and water influx (Table I; Fig. 9), but it was apparent that the mechanisms were very different. In preliminary experiments with MIA a considerable increase in protein was noted in the effluent and the increase in aqueous flow was thought to be caused by increased permeability of the blood–aqueous barrier. This view was supported by the results of the electrical measurements. MIA caused a severe fall in the blood–aqueous P.D. and a reduction of the short-circuit current, neither finding being consistent with increased active transport. It seems likely that MIA reduced active transport, but that this was more than offset by a rise in ultrafiltration due to increased permeability of the barrier.

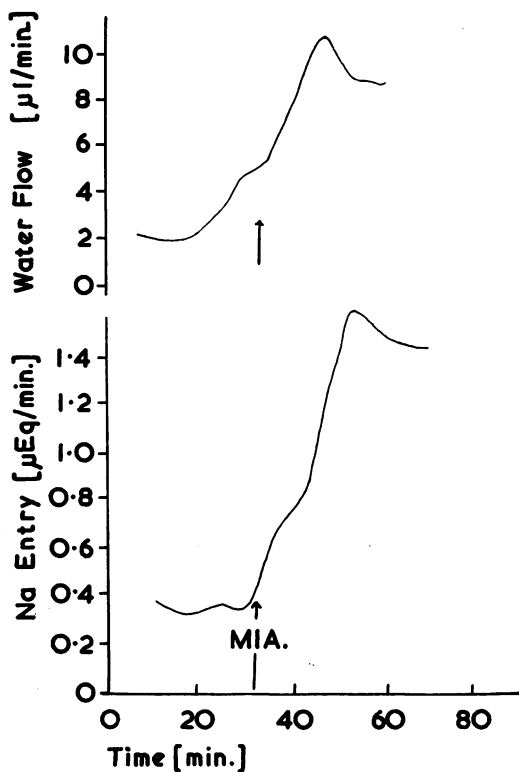

FIG. 9.—Values for sodium and water influx before and after administration of mono-iodoacetic acid (0.006 mM/min.) *via* the lingual artery.

Azide, in contrast with MIA, increased the blood–aqueous P.D. very considerably, in one case by 15 mV, and it also appeared to increase the short-circuit current. The protein content of the effluent was not appreciably raised. The action of azide on retinal potentials has been studied extensively by Noell (1953, 1954), who has shown that the increase in retinal potential arises in the pigment epithelium. In the present experiments, anoxia reversed the rise in blood–aqueous P.D. caused by azide, whilst MIA had little effect

(Fig. 4). Furthermore, the records of blood-aqueous P.D. after azide indicated the presence of exaggerated electroretinographic *c*-waves (Fig. 7). These findings agree well with those of Noell (1953) and, taken in conjunction with the increased flux of sodium into the aqueous, render it difficult to escape the conclusion that the electrical activity of the retina or the pigment epithelium is in some way related to the processes causing formation of the aqueous humour.

The pigment epithelium of the retina is continuous with the outer (pigmented) layer of the ciliary epithelium, and one would expect to find that the pigmented cells of the ciliary body had some properties in common with those of the retina, of which their response to administration of azide could well be an instance. Conversely, on the basis of the present results, it is not possible to decide what part, if any, the retinal pigment epithelium may play in the actual transport of ions into the aqueous. It is worth noting that the electrical conductivity of the vitreous is fairly high (some 10 per cent. less than that of isotonic saline: Maurice, 1957) and that, should there be appreciable influx across the retinal pigment epithelium, the vitreous would not greatly impede the movement of ions passing through it.

It seemed likely that, were the ion fluxes into the aqueous dependent upon the electrochemical P.D. blood and aqueous, then alteration of this P.D. by imposing an electrical potential from an external source would modify the influx rates (*cf.* Ussing, 1959). This possibility is not entirely dissimilar from that which was investigated by Friedenwald and Stiehler (1938), who were able to alter the direction of aqueous flow by imposing an electrical potential across the blood-aqueous barrier of both eyes in rabbits. The magnitude of the external E.M.F. (20V) in their experiments has been criticized, not unjustifiably, by Davson (1956) as being unphysiological, but since Friedenwald and Stiehler (1938) did not measure the blood-aqueous P.D. it is possible that the potential which they actually imposed across the blood-aqueous barrier was not so large as might appear at first sight. In the present experiments the blood-aqueous P.D. was measured as described above.

Changes in influx were dependent upon the direction of the imposed potential (Table II), although some results suggested that negative potentials were more effective in reducing the nett flux than positive potentials in increasing it (Fig. 8).

It is evident that rendering the aqueous more positive with respect to the plasma caused an increase in sodium and water influx and *vice versa*. In this, the externally-applied P.D. appears to simulate the effects of altering the rate of active membrane transport, and it is possible that membrane activity is, in fact, modified. Working with gastric mucosa, Rehm (1945) and Crane, Davies, and Longmuir (1948a,b) observed that application of current from an external source in such a way as to enhance the natural P.D. across the tissue increased H⁺ ion production at the mucosal side whereas reversal of

the current decreased secretion. It was suggested that the external E.M.F. might have increased the return of electrons from the mucosal to the serosal side by assisting an electron transport system (Crane, Davies, and Longmuir, 1948a) and a similar explanation is tenable in the present experiments. It was not possible to relate usefully the imposed current to the changes in influx.

A recent study of the ciliary body by Berggren (1960) using microelectrodes showed that both the pigmented and unpigmented layers contribute to the potential difference between the blood and aqueous humour. The membrane potential of the pigment cell layer was about 50 mV negative and that of the unpigmented epithelium was about 20 mV negative with respect to the stroma; the aqueous was 5–10 mV positive to the stroma. It follows that, if we consider the unpigmented epithelium, the cells would be some 30 mV positive with respect to the pigment layer, whilst the aqueous would be 20–30 mV positive to the unpigmented cells. In these circumstances it is possible that, were the potential of the pigmented cell layer to be reduced without at the same time inhibiting the unpigmented cells, the blood–aqueous P.D. would tend to increase. If the increased blood–aqueous P.D. induced by azide is considered in these terms, the present hypothesis would imply that a reduction of pigment layer P.D. was associated with increased Na^+ influx. On the other hand, Noell (1953) found, in the retina, that administration of iodate, which caused histological damage to the pigment epithelium, abolished the steady retinal potential. The extent to which these findings may be applied to the anterior prolongation of the retinal pigment epithelium in the ciliary body is only conjectural, but they are not entirely in accord with the hypothesis outlined, according to which iodate would be expected to increase the steady potential.

The increase in nett sodium influx in the azide experiments also requires some explanation, since this agent might be expected to depress ion transport, as in frog skin (Huf, Doss, and Willis, 1957). One possibility is that azide increases the blood–aqueous P.D. in one region of the barrier and that this increased P.D. enhances sodium influx, acting in rather the same way as an E.M.F. imposed from an external source. The results of the experiments with an externally-imposed E.M.F. certainly suggest that long-term alterations of the blood–intra-ocular P.D., such as might arise from changes of retinal activity, could modify the sodium flux into the eye.

Another explanation supposes that azide inhibits the uptake of sodium and potassium from the aqueous side of the barrier; this would decrease the total sodium flux across the barrier out of the eye and, other things being equal, cause an increased nett flux from blood to aqueous (*cf.* Conway, Ryan, and Carton, 1954). Such a reduction in total sodium outflux might also account for an increase of the P.D. across the barrier. This last hypothesis requires that azide does not inhibit the extrusion of sodium into the aqueous and thereby reduce the total sodium influx from blood to

aqueous. Such an insensitivity of sodium extrusion to inhibition by azide has been observed by Carey, Conway, and Kernan (1959) in frog sartorius muscle. The actions of DNP and strophanthin-G would be explained as resulting from the inhibition of extrusion of sodium into the aqueous. This hypothesis also accounts for the inhibition of the azide effect by DNP.

Summary

Measurements of blood-aqueous potential difference (P.D.), sodium and water influx into the aqueous, and short-circuit current across the blood-aqueous barrier have been made using rabbits as experimental animals.

The mean value for the blood-aqueous P.D., measured between electrodes in the posterior chamber and in the ear vein was found to be 6.20 ± 0.51 mV (aqueous positive to plasma).

The blood-aqueous P.D. was related to the influx of sodium and water into the aqueous; administration of DNP and strophanthin-G reduced influx rates and P.D., but both were increased markedly by sodium azide.

This relationship did not obtain if the blood-aqueous barrier became highly permeable to protein, as was the case when mono-iodoacetate was administered. Under these circumstances the influx rates increased independently of the P.D.

The influx rate of sodium was modified by an electromotive force (E.M.F.) applied from an external source; an applied E.M.F. which tended to enhance the naturally occurring blood-aqueous P.D. also increased the sodium influx and *vice versa*.

Findings with azide suggested that the pigmented cell layer of the ciliary body played an important part in blood-aqueous transport. The effects of strophanthin-G and of DNP on the blood-aqueous barrier resembled their actions upon sodium transport in frog skin.

Approximate values for the short-circuit current in the presence of metabolic inhibitors revealed changes which were parallel to the alterations in sodium influx.

The author wishes to express his thanks to Sir Stewart Duke-Elder for his advice and encouragement and for the facilities afforded to make this investigation possible.

REFERENCES

- BERGGREN, L. (1960). *Acta physiol. scand.*, **48**, 461.
 CAREY, M. J., CONWAY, E. J., and KERNAN, R. P. (1959). *J. Physiol. (Lond.)*, **148**, 51.
 COLE, D. F. (1959). *Brit. J. Ophthalmol.*, **43**, 268.
 ——— (1960a). *Ibid.*, **44**, 225.
 ——— (1960b). *Ibid.*, **44**, 739.
 CONWAY, E. J., RYAN, H., and CARTON, E. (1954). *Biochem. J.*, **58**, 158.
 CRANE, E. E., DAVIES, R. E., and LONGMUIR, N. M. (1948a). *Ibid.*, **43**, 321.
 ———, ———, ——— (1948b). *Ibid.*, **43**, 336.
 DAVSON, H. (1956). "Physiology of the Ocular and Cerebrospinal Fluids". Churchill, London.
 FISCHER, F. P. (1932). *Arch. Augenheilk.*, **106**, 428.
 FRIEDENWALD, J. S., and STIEHLER, R. D. (1938). *Arch. Ophthalm. (Chicago)*, **20**, 761.

- FUHRMAN, F. A. (1952). *Amer. J. Physiol.*, **171**, 266.
- HUF, E. G., DOSS, N. S., and WILLS, J. P. (1957). *J. gen. Physiol.*, **41**, 397.
- KOEFOED-JOHNSEN, V. (1957). *Acta physiol. scand.*, **42**, Suppl. 145, p. 87.
- LEHMANN, G., and MEESMANN, A. (1924). *Pflügers Arch. ges. Physiol.*, **205**, 210.
- MAURICE, D. M. (1951). Ph.D. Thesis, University of London.
- (1957). *J. Physiol. (Lond.)*, **137**, 110.
- NOELL, W. K. (1953). USAF School of Aviation Medicine, Project No. 21-1201-0004, Report No. 1.
- (1954). *Amer. J. Ophthalm.*, **38**, Pt. 2, 78.
- REHM, W. S. (1945). *Amer. J. Physiol.*, **144**, 115.
- SCHOFFENIELS, E. (1955). *Arch. int. Physiol.*, **63**, 361.
- SOLOMON, A. K. (1959). In "1er Colloque de Biologie de Saclay: The Method of Isotopic Tracers applied to the Study of Active Ion Transport", pp. 106-124. Pergamon Press, London.
- , GILL, T. J., and GOLD, G. L. (1956). *J. gen. Physiol.*, **40**, 327.
- USSING, H. H. (1949). *Acta physiol. scand.*, **17**, 1.
- (1959). In "1er Colloque de Biologie de Saclay: The Method of Isotopic Tracers applied to the Study of Active Ion Transport", pp. 139-154. Pergamon Press, London.
- (1960). "Handbuch der experimentellen Pharmakologie", vol. 13, pp. 1-195. Springer, Berlin.
- and ANDERSEN, B. (1956). "Proc. 3rd Int. Biochem. Congr., Brussels, 1955", pp. 434-440. Vaillant-Cormanne, Liège; Academic Press, New York.
- and ZERAHN, K. (1951). *Acta physiol. scand.*, **23**, 110.