

THE BRITISH JOURNAL
OF
OPHTHALMOLOGY

MAY, 1948

COMMUNICATIONS

THE OPTICS OF CONTACT LENSES

BY

A. G. BENNETT

THE subject indicated by the title of this paper ranges over a wide field, but only that part of it which is of significance to prescribers has been dealt with here. An attempt has been made to present the subject matter as simply as possible without detriment to precision. Gaussian methods in particular have been avoided wherever they appeared unnecessary. On the other hand, attention is drawn to some commonly neglected factors which are of importance in contact lens prescribing.

1.—Neutralising the cornea

The idea of contact lenses was apparently conceived by Sir John Herschel after reading Airy's account of the correction of his own astigmatism by means of a spherocylindrical lens.

Herschel, though admiring Airy's ingenuity, evidently thought this too indirect a way of overcoming what he termed "malconformations of the cornea" and suggested instead a "spherical capsule of glass" filled with animal jelly and applied to the cornea. Thus the contact lens was first conceived as a means of re-moulding the cornea, or, expressing more accurately, of building it up into a truly spherical surface, the function of the glass shell being purely mechanical and not optical.

Completely to neutralise the anterior surface of the cornea would require a fluid medium of the same refractive index as the corneal substance, namely 1.376, whereas the refractive index of all the solutions at present in use is slightly lower, being about 1.336. Since, for a given radius, the power of a surface is proportional to the refractivity (refractive index minus unity) of the medium, it follows that the fluid neutralises only $336/376$ or approximately nine-tenths of the anterior power of the cornea. It will hence be realised that the effect of corneal irregularities or deformities is not completely counteracted.

The extent to which a contact lens neutralises corneal astigmatism is not a simple matter to determine. If we accept the constants of Gullstrand's No. 1 Schematic Eye as a basis for discussion, the following picture emerges. The corneal radii are 7.7 and 6.8 mm. respectively, its centre thickness 0.5 mm. and its refractive index 1.376, the index of the aqueous humour being 1.336. From this it can be calculated that the anterior surface of the cornea has a power of +48.83D., and the posterior surface of the cornea a power of -5.88D., the ratio of these two powers being -8.3:1.

Now if the corneal astigmatism is ascribed to its anterior surface only, it would follow as before that the fluid meniscus will correct nine-tenths and leave one-tenth uncorrected. If, on the other hand, both surfaces of the cornea are assumed to be toroidal with their meridians of maximum curvature in similar orientation, then the astigmatism due to the posterior surface will annul a portion of that due to the anterior surface. Suppose, for example, that both surfaces of the cornea exhibit the same percentage difference between the two principal radii, then since the surface powers are in the ratio -8.3:1, it follows that the posterior surface will neutralise nearly one-eighth of the astigmatism created at the first surface. The fluid lens neutralising nine-tenths for its own part, there would thus be a very small degree of over-correction.

One further point is worthy of mention. In order to make some allowance for the posterior surface of the cornea, keratometers are calibrated for an empirical refractive index of 1.3375.

For example, the dioptric reading corresponding to a radius of 337.5

7.7 mm. is $\frac{337.5}{7.7} = +43.83D.$, whereas taking the true index of

1.376 the corresponding power is +48.83D.

As a result, the reading given by a keratometer represents, in actual fact, $337.5/376$, or very nearly nine-tenths of the power of the anterior surface. Similarly, the "corneal astigmatism" as measured by the keratometer represents in reality nine-tenths of the astigmatism due to the front surface only. The keratometer is incapable of giving reliable information as to the total corneal astigmatism. To accept its reading involves the assumption—which may or may not be justified—that the posterior surface is a replica of the anterior, with its principal meridians identically orientated, and its principal radii both reduced to approximately nine-tenths of the corresponding radii of the anterior surface.

2.—The Effectivity relationship

The optical theory of contact lenses cannot be adequately expounded without reference to the principle of effectivity, which deals with the change in the dioptric vergence of a pencil of rays over a given length of its path. (The vergence L dioptries at a given point is defined as the reciprocal of the distance l metres from the given point to the origin or focus of the pencil.) In passing it may be recalled that the first detailed exposition of

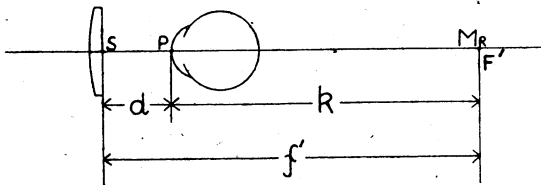

FIG. 1.

Spectacle and ocular refraction.

geometrical optics based on the idea of vergences was due to Sir John Herschel, who used the term "proximity" to denote the reciprocal of linear distance.

As an illustration we may take the relationship between spectacle and ocular refraction, which assumes some importance in contact lens prescribing. Fig. 1 represents a hypermetropic eye with its far point at M_r . In everyday practice, the refractive error is invariably expressed in terms of the correcting lens

which, placed at the "spectacle point" S , renders the eye emmetropic. The second principal focus F' of this lens must coincide with the far point. Its power F dioptres, the reciprocal of the focal length f' in metres, is termed the spectacle refraction. The distance in metres from the corneal vertex (more strictly, from the eye's first principal point) to the far point M_r is usually denoted by the symbol k and its reciprocal K is termed the ocular refraction. If the vertex distance from the spectacle point to the cornea is d metres, it is clear from the diagram that $k = f - d$ and hence

$$K = \frac{1}{k} = \frac{1}{f-d} = \frac{F}{1-dF} \dots \dots \dots (1)$$

K represents the back vertex power of the contact lens required to correct an ametropia whose spectacle correction is F . By "contact lens" is meant, in this connection, the system comprising the glass or plastic shell and the liquid lens combined.

In general, a pencil with a vergence L dioptres at a given point will have the vergence L_d after travelling a distance d metres in air where

$$L_d = \frac{L}{1-dL} \dots \dots \dots (2)$$

If the pencil is travelling in a medium of refractive index n , d in this expression must be replaced by the "reduced distance" d/n . We shall need to make further use of this effectivity expression.

(The symbols and sign convention employed in this paper are those standardised by the Northampton Polytechnic Institute, London, E.C.1, and the Imperial College of Science.)

3.—Theory of afocal lenses

The first spherically ground lenses to be made available were produced by Carl Zeiss and were based on the Herschelian idea of reshaping the cornea. The glass lens itself was afocal in air. It is important to have a precise definition of this term; to say that it denotes a lens or system "without power" is not sufficient. An afocal lens is a lens without power with respect to infinitely distant objects; that is to say, a parallel pencil incident at the first surface emerges as a parallel pencil from the second. Such a lens does exert a focal effect with respect to near objects. That this distinction is not purely academic will emerge at a later stage.

OPTICS OF CONTACT LENSES

Although the centre thickness of any contact lens is necessarily small, it is not so in comparison with the radii of curvature and, consequently, thin lens formulae cannot be used without introducing serious errors. Take, for example, a lens with a posterior corneal radius of 8 mm. and centre thickness 0.6 mm., the refractive index of the material being 1.5. If the front surface were also ground to a radius of exactly 8 mm. in accordance with thin lens theory, the resulting lens would be far from afocal: its back vertex power would be no less than +1.60D.

The precise relationship between the radii of curvature of an afocal lens is easily found. Denoting the radii by r_1 and r_2 respectively, the centre thickness of the lens by t and the refractive index of the material by n , the two surface powers F_1 and F_2 are given by the text-book formulae

$$F_1 = \frac{n-1}{r_1} \quad \dots \quad \dots \quad \dots \quad \dots \quad (3)$$

$$\text{and} \quad F_2 = \frac{n-1}{-r_2} \quad \dots \quad \dots \quad \dots \quad \dots \quad (4)$$

r_1 and r_2 being in metres.

If we now imagine a parallel axial pencil incident at the front surface, its vergence after refraction will clearly be equal to F_1 . After travelling a distance t metres towards its focus, its vergence will be increased to

$$\frac{F_1}{1 - \frac{t}{n} F_1}$$

in accordance with the effectivity formula. Hence, if the pencil is to emerge parallel, *i.e.*, with zero vergence, after refraction at the second surface, the power F_2 of the latter must be such that

$$\frac{F_1}{1 - \frac{t}{n} F_1} + F_2 = 0$$

$$\text{whence} \quad F_1 + F_2 - \frac{t}{n} F_1 F_2 = 0 \quad \dots \quad \dots \quad \dots \quad (5)$$

The above may be followed more easily by reference to Fig. 2, which indicates the vergence of the pencil before and after each refraction.

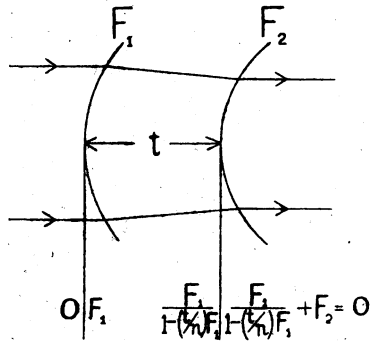

FIG. 2.

Passage of light through an afocal lens. The vergences are shown before and after each refraction.

The left-hand side of the last equation will be recognised as the formula for the equivalent power of a thick lens. The equation can be re-arranged in the form

$$F_1 = \frac{-F_2}{1 - \frac{t}{n} F_2} \quad \dots \quad \dots \quad \dots \quad (6)$$

showing the necessary relationship between the two surface powers of an afocal lens. To obtain the relationship in terms of radii, we replace F_1 by $\frac{n-1}{r_1}$ and F_2 by $\frac{n-1}{-r_2}$, as above, and thus arrive at the equation

$$\frac{n-1}{r_1} = \frac{\frac{(n-1)}{r_2}}{1 + \frac{t}{n} \cdot \frac{n-1}{r_2}}$$

which simplifies to

$$r_1 = r_2 + \left(\frac{n-1}{n} \right) t \quad \dots \quad \dots \quad \dots \quad (7)$$

Hence the radius of curvature of the front surface of an afocal lens must always exceed that of the rear surface by $\left(\frac{n-1}{n} \right) t$.

It can similarly be shown that in order to produce a contact lens with a given back vertex power, the required value of r_1 can

be found by adding $\left(\frac{n-1}{n}\right)t$ to the value yielded by thin lens theory.

The correction of ametropia with an afocal contact lens is entirely dependent upon the fluid meniscus, which is bounded by the posterior corneal surface of the contact lens (radius r_2) and the anterior surface of the cornea itself (radius r_c). It hence becomes necessary to determine the value of r_2 which will impart the required power to the fluid lens. An approximation to this value may be found as follows.

Considering the liquid lens as a separate entity and ignoring its centre thickness for the sake of simplicity, its power F is given by the thin lens formula

$$F = 1000 (n-1) \left\{ \frac{1}{r_2} - \frac{1}{r_c} \right\}$$

r_2 and r_c being expressed in millimetres. Assigning to n the usual refractive index of 1.336 this expression becomes

$$F = \frac{336}{r_2} - \frac{336}{r_c}$$

Since the liquid lens is in contact with the cornea, its power F must be made equal to the ocular refraction K . Hence we may write

$$K = \frac{336}{r_2} - \frac{336}{r_c}$$

$$\text{or } \frac{336}{r_2} = K + \frac{336}{r_c} \quad \dots \dots \dots (8)$$

Having calculated K from the spectacle refraction and measured the corneal radius on the keratometer, we can thus ascertain the required value of r_2 .

Assuming, however, that the keratometer has its dioptric scale calibrated for a refractive index of 1.3375 in accordance with standard practice, the power C of the cornea as recorded on the instrument will be equal to $337.5/r_c$ and hence we may substitute C for $336/r_c$ in equation (8) without introducing serious error. We thus obtain the following simplified expression

$$r_2 = \frac{336}{K + C} \quad \dots \dots \dots (9)$$

The literature of contact lenses contains various graphical representations of this formula.

It should be pointed out that formula (9) is only approximate because it does not take into account the thickness of the liquid lens. This point would be worth further discussion were it not for the fact that the fitting of afocal lenses is no longer a commonly practised technique.

Its abandonment was largely due to the resulting conflict between optics and haptics. It can readily be calculated from formula (9), taking an average value of +43D. for the power of the cornea, that the correction of ocular ametropia over the range +12D. to -12D. requires afocal lenses with inner corneal radii varying from 6.1 to 10.8 mm. Indeed, at one time Zeiss afocal lenses were available with radii 5 to 11 mm. in half-millimetre stages. When it is realised that a lens with a 5 mm. corneal radius has a maximum corneal aperture of 10 mm., whilst a lens with 11 mm. radius cannot possibly clear an average cornea, one wonders how such lenses were ever made with any hope of a successful fitting.

It may be added that there is no virtue whatever in making contact lenses afocal and relying entirely upon the liquid lens for the correction of ametropia. From an optical standpoint it is quite immaterial how the total refractive power is divided between the lens itself and the fluid meniscus, whilst from the manufacturing standpoint a perfect afocal lens is certainly no easier to make than any other. On the contrary, small errors in power and defects of surface figure, waviness and so on, are more easily detected in an afocal lens than in one incorporating a refractive effect.

4.—Lenses with added power

Owing to the difficulties briefly alluded to above, it is now the usual practice to select the shallowest standard curve that will clear the cornea and to incorporate any additional power that may be required in the lens itself. Since even small variations in the fluid thickness may have an appreciable focal effect, it is important that refraction should be carried out with the patient wearing a contact lens identical in regard to its back surface and overall size with the lens that is finally to be worn. If any alterations are made, an attempt should be made to estimate their effect on the thickness of the fluid meniscus so that an appropriate allowance can be calculated.

The optical problem is illustrated in Fig. 3. The patient is presumed to be wearing either a semi-finished moulded lens or else a standard trial lens of the appropriate specification, and is found to require an additional power D at a distance d from

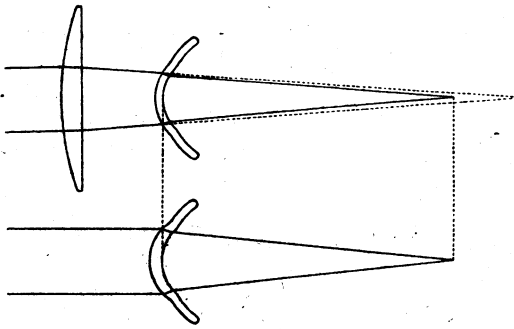

FIG. 3.

Basic optical requirement. The finished lens must have the same back vertex power as the trial contact lens and auxiliary spectacle correction.

the vertex of the contact lens. If the back surface of the latter is identical with that of the lens to be finally worn, the fluid meniscus will be the same in each case. It follows, therefore, that the back vertex power in air of the final lens must be made to coincide with that of the original system in air if it is to have the same effective power at the cornea.

The back vertex power F_v of the system can be calculated as follows. Suppose the power of the auxiliary lens is +10D., the vertex distance d 12 mm., and that the contact lens worn during refraction is afocal with a posterior corneal radius of 8 mm., centre thickness 0.6 mm. and refractive index 1.5. According to formula (7) the corneal radius r_1 of the front surface is given by

$$r_1 = r_2 + \left(\frac{n-1}{r}\right)t = 8.00 + \left(\frac{0.5}{1.5}\right)0.6 = 8.20 \text{ mm.}$$

Substituting in (3) and (4), the two surface powers are therefore 500/8.20 and 500/-8.00, giving

$$F_1 = +60.98\text{D. and } F_2 = -62.50\text{D.}$$

We can now find the back vertex power of the system by tracing through it a parallel pencil of rays incident on the auxiliary lens. After refraction by this lens, the pencil emerges with a vergence of +10D. and travels 12 mm. or 0.012 metres in air before meeting A_1 , the front vertex of the contact lens. In accordance with the effectivity formula (2), the increased vergence of the pencil at A_1 will be

$$\frac{+10}{1 - 0.012 \times 10} = \frac{+10}{0.88} = +11.36 \text{ D.}$$

Thus the 12 mm. air space has increased the effective power of the trial lens by +1.36D. However, as pointed out above, an

afocal lens is without power only in respect to infinitely distant objects and we must therefore proceed to trace the pencil through it.

After refraction by the front surface of the afocal lens, the vergence becomes $+11.36 + F_1 = +11.36 + 60.98 = +72.34D$. The pencil now travels 0.6 mm. through a medium of refractive index 1.5 before meeting A_2 , the back vertex of the contact lens. Hence, again applying the effectivity formula, the vergence at A_2 is

$$\frac{+72.34}{1 - \frac{.0006 \times 72.34}{1.5}} = +74.50 D.$$

Finally, after refraction by the back surface, the pencil emerges with a vergence of $+74.50 + F_2 = +74.50 - 62.50 = +12.00D$. This gives us the back vertex power of the system, and the final contact lens to be worn permanently must be made with the same back vertex power in air.

Reference should be made to Fig. 4 (not drawn to scale) in which the vergences of the pencil are shown before and after each refraction.

Repeating the procedure for an auxiliary lens of power $-10D$, with all other particulars as before (see Fig. 5), it will be found

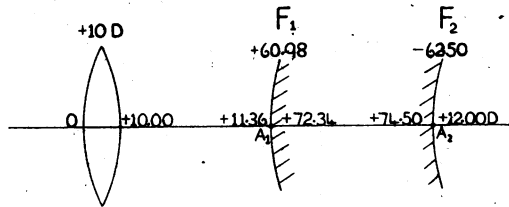

FIG. 4.

Computation of back vertex power: convergent auxiliary lens and afocal contact lens.

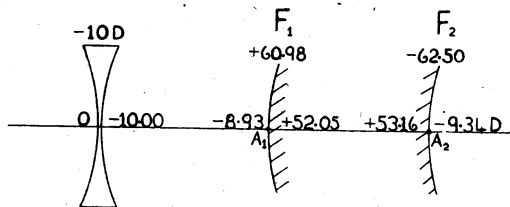

FIG. 5.

Computation of back vertex power: divergent auxiliary lens and afocal contact lens.

that the vergence at A_1 is $-8.93D.$, whereas the back vertex power of the system is $-9.34D.$

Analysing these results we may conclude that the total effectivity correction consists of two portions, one due to the air space or vertex distance and the other due to refraction by the trial contact lens. When the auxiliary lens is of positive power, the two effects are additive; with a negative auxiliary lens they are in opposition.

In the above examples the contact lens worn during refraction has been assumed to be afocal, but exactly the same procedure should be followed in principle whatever its power.

Though difficult mechanically it is theoretically quite simple to incorporate an astigmatic correction in a glass or plastic contact lens. For technical reasons it is usually more convenient to make the inner corneal surface toroidal, in which case allowance must be made for the fact that when filled with fluid the back surface of the lens is partly neutralized. If the refractive indices of the lens material and fluid are n and 1.336 respectively, each dioptré of effective cylinder power will need $(n - 1)/(n - 1.366)$, or approximately 3 dioptrés of cylinder power worked on the lens itself.

5.—Magnification of the retinal image

An exhaustive investigation of this subject on orthodox Gaussian lines has been carried out by J. Boeder.¹ In his paper he deduced accurate formulae which took into account the effects of lens and fluid thicknesses. Unfortunately, one of Boeder's graphs seems to have been drawn upon by other writers, who have failed to study the accompanying text with sufficient care. As a result, a statement is sometimes seen to the effect that in myopia of $20D.$ contact lenses give a magnification of 46 per cent. In the sense in which it would be ordinarily understood, this statement is not even approximately true.

Supposing an eye to be corrected by a lens placed with its back vertex at a specified distance from the cornea, the size of the retinal image can be varied slightly by altering the form and thickness of the lens. This is, in fact, one of the expedients used in designing lenses for the correction of aniseikonia. Compared, however, with the change in image size introduced by placing the lens in contact with the eye instead of at the spectacle point, the effects due to form and thickness are of a secondary nature and can thus be neglected in a general discussion. In optical terminology, we shall assume the equivalent powers to be

¹ *Arch. of Ophthalm.* (U.S.A.). January, 1938.

the same as the vertex powers. A very much simpler approach to the whole problem is thereby made possible and a Gaussian analysis can be avoided.

First of all we must establish certain definitions. Following Emsley² we use the term "Spectacle Magnification" to denote the ratio of the retinal image in the corrected ametropic eye to the blurred or sharp image in the uncorrected eye. With contact lenses it is easily shown (ignoring thicknesses) that the spectacle magnification is in all cases unity.

A graphical demonstration of this fact is given in Fig. 6, which represents a "reduced" hypermetropic eye, the corneal vertex being denoted by P and the macula by M'. Parallel rays are shown emanating from the extremity Q of a distant object situated

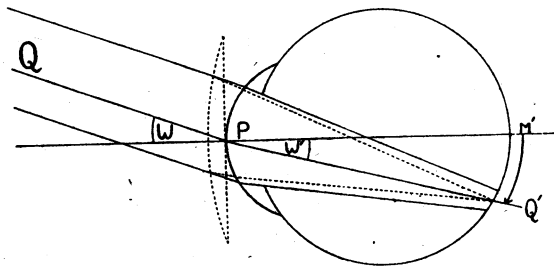

FIG. 6.

Spectacle magnification with a contact lens.

on the axis and making with it an angle w . The ray incident at P may be regarded as the central ray of the pencil entering the pupil. Hence, if this ray after refraction impinges on the retina at Q' , then Q' represents the centre of the retinal blur circle. Furthermore, if the eye accommodates so as to neutralize the refractive error, the sharp image point formed on the retina will still be located at Q' . Thus in either case the size of the retinal image is $M'Q'$.

Suppose that the eye is now corrected by means of a thin convex lens (shown in dotted outline) placed in contact with the cornea. The central ray QP of the incident pencil passes through the optical centre of this lens and is thus undeviated by it, so that the retinal image point Q' occupies the same position as previously. In other words, the spectacle magnification is unity. The same argument obviously applies to the myopic eye.

The ratio of the retinal image size in the corrected ametropic

² "Visual Optics." Hatton Press.

eye to that in the schematic emmetropic eye is termed the "Relative Spectacle Magnification." For any given eye this ratio can be calculated only if the equivalent power of the eye is known. For this reason it is customary to develop two sets of formulae, one applicable to "axial ametropia" and the other to "refractive ametropia." This concept of ametropia as being *either axial or refractive* seems to the author altogether too schematic. It means, for example, that an eye hypermetropic 5D. must have a power of either +60D. ("axial" error) or else +55D. ("refractive" error)—no other values being admitted. Most of the published tables giving the "magnification" obtained with contact lenses are, in fact, tables of relative spectacle magnification on the assumption of purely axial ametropia. Although

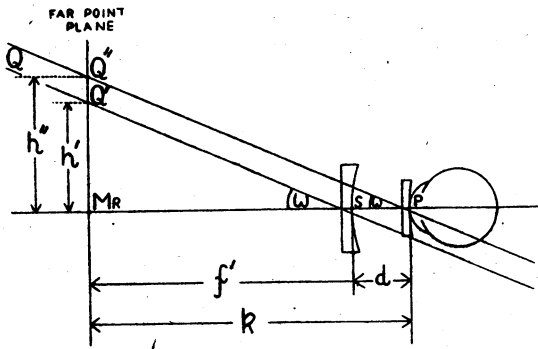

FIG. 7.

Comparison of image sizes in myopia between orthodox spectacles and contact lenses.

giving an indication of theoretical possibilities, their value in practice is questionable.

An exact comparison between orthodox spectacles and contact lenses can be deduced without making any such assumptions. To correct ametropia, a lens must form images of distant objects in the far point plane of the eye. Hence, if lens A forms an image in the far point plane 10 per cent. larger than lens B, the retinal images must also be in the same ratio irrespective of the power of the eye.

Fig. 7 illustrates a myopic eye with its far point at M_r , corrected by a lens placed at the spectacle point S. Parallel rays are shown emanating from Q, the extremity of a distant object situated on the axis and making with it an angle w . Since rays passing through the optical centre of a lens are undeviated, the size h' of the image formed in the far point plane will be M_r

Q'. If the eye is now corrected by a contact lens, the size h'' of the image $M_r Q''$ formed in the far point plane is again determined by the ray passing through the optical centre. By similar triangles it will be apparent that the two image sizes are in the same ratio as the focal lengths of the lenses, *i.e.*,

$$\frac{h''}{h'} = \frac{k}{f'} = \frac{F}{K}$$

From formula (1),

$$K = \frac{F}{1-dF}$$

Hence
$$\frac{h''}{h'} = 1-dF \quad \dots \quad \dots \quad \dots \quad (10)$$

Finally, putting d in millimetres, the percentage difference Δ is given by

$$\Delta = \frac{-dF}{10} \% \quad \dots \quad \dots \quad \dots \quad (11)$$

Thus if F , the spectacle refraction, is $-20D$. and the vertex distance 12 mm. , a contact lens will give a retinal image 24 per cent. larger than the orthodox spectacle correction.

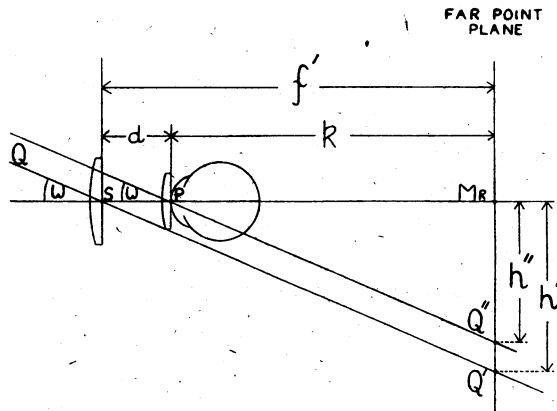

FIG. 8.

Comparison of image sizes in hypermetropia between orthodox spectacles and contact lenses.

Fig. 8 illustrates the position in hypermetropia, from which it will be seen that the same expression holds good. In this case

the smaller retinal image is given by the contact lens, the difference amounting to 7.2 per cent. in hypermetropia of 6D.

6.—Contact lenses in anisometropia

Assuming axial errors only, eyes with marked anisometropia will have different retinal image sizes, a fact which may by itself give rise to symptoms. Spectacles placed at the anterior focal points of the eyes would equalise the retinal images. Contact lenses would leave the disparity unchanged. On the other hand, contact lenses have the great advantage of obviating the unequal vertical prismatic effects arising with orthodox spectacles when the eyes rotate to view objects above or below the optical axis.

In unilateral aphakia, contact lenses have the advantage on both counts. The aphakic eye that was previously emmetropic or nearly so has a retinal image about 25 per cent. larger than its fellow, when the correction is worn at 12 mm. from the cornea. Contact lenses reduce this disparity to approximately 9 per cent. and it is stated that binocular fusion has thereby been rendered possible in certain cases.

7.—Contact lenses in near vision

Reference has been made above to the relationship between spectacle and ocular refraction. A similar relationship exists between spectacle and ocular accommodation, *i.e.*, between the nominal accommodation reckoned at the spectacle point and the actual effort of accommodation which the eye is required to make.

The left-hand side of Fig. 9 represents a hypermetropic eye corrected by a +6 D. lens placed 12 mm. from the cornea. Parallel rays after refraction by this lens reach the cornea with a vergence of +6.47 D. in accordance with the effectivity formula. In the lower

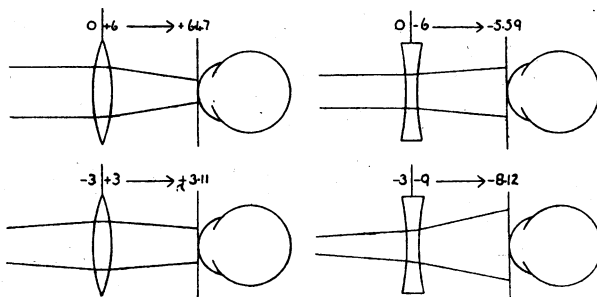

FIG. 9.

Spectacle and ocular accommodation.

half of the diagram, light is imagined to diverge from a point $33\frac{1}{2}$ cms. or -3.00 D. from the lens. After refraction the vergence is $+3.00$ D., which is increased to $+3.11$ D. at the eye as shown. The effort of accommodation required to focus at $33\frac{1}{2}$ cms. is therefore $6.47 - 3.11$ or 3.36 D. Wearing a contact lens for distance, the accommodation needed to focus at $33\frac{1}{2}$ cms. from the spectacle point or 34.5 cms. from the eye would be only 2.90 D.

The position in myopia is illustrated in the right-hand side of Fig. 9, which shows that a myope corrected by -6.00 D. at 12 mm. from the cornea has to exert 2.53 D. of accommodation in order to focus at $33\frac{1}{2}$ cms. A greater effort of accommodation would be needed if a contact lens were worn.

8.—Sources of error and tolerances

We conclude with a very brief review of possible sources of error in prescribing and manufacturing. Assuming that the back vertex power required has been accurately computed as described above, there are still other factors to be considered. For example, an error of only 0.05 mm. in the inner corneal radius of the lens will produce an error in the refractive effect exceeding 0.25 D. Again, assuming the inner radius to be perfectly accurate, it requires an error of only 0.03 mm. in the outer corneal radius to alter the power by 0.25 D. A similar error in vertex power would result from making the lens 0.1 mm. too thick or too thin.

The thickness of the fluid meniscus is not a negligible factor, since every 0.1 mm. of fluid adds approximately 0.12 D. to the effective power of the contact lens system. An error in the corneal aperture will affect the thickness of fluid and thus alter the power. For example, an increase of 0.25 mm. in the corneal aperture will add about $+0.12$ D. to the power simply by increasing the fluid thickness. All the above figures are based on average radii and dimensions.

In short, there are several sources of error which may be small in themselves but may quite easily reach a formidable total if their effect is additive. The greatest care should therefore be taken by both manufacturer and prescriber.

One thing which a study of these tolerances has brought home to the author is the extraordinary performance required on the part of nature in order to produce a perfect emmetropic eye.

