



Published in final edited form as:

Behav Genet. 2012 July ; 42(4): 549–558. doi:10.1007/s10519-012-9527-0.

Gene-by-Socioeconomic Status Interaction on School Readiness

Mijke Rhemtulla and
University of Kansas

Elliot M. Tucker-Drob
University of Texas at Austin

Abstract

In previous work with a nationally representative sample of over 1,400 monozygotic and dizygotic twins born in the United States, Tucker-Drob, Rhemtulla, Harden, Turkheimer, and Fask (2011; *Psychological Science*, 22, 125–133) uncovered a gene \times environment interaction on scores on the Bayley Short Form test of mental ability at 2 years of age—higher socioeconomic status (SES) was associated not only with higher mental ability, but also with larger genetic contributions to individual differences in mental ability. The current study examined gene \times SES interactions in mathematics skill and reading skill at 4 years of age (preschool age) in the same sample of twins, and further examined whether interactions detected at 4 years could be attributed to the persistence of the interaction previously observed at 2 years. For early mathematics skill but not early reading skill, genetic influences were more pronounced at higher levels of SES. This interaction was not accounted for by the interaction observed at 2 years. These findings indicate that SES moderates the etiological influences on certain cognitive functions at multiple stages of child development.

Keywords

gene-by-environment interaction; reading; mathematics; school readiness; socioeconomic status

Family socioeconomic status (SES) is related to children's cognitive performance even before entry into formal schooling (Duncan, Yeung, Brooks-Gunn, & Smith, 1998; Feinstein, 2003; Leseman & de Jong, 1998). This observation is particularly important in light of recent findings that children's school readiness skills, particularly early mathematics and reading skills, are strongly predictive of sustained academic achievement throughout the school years (Duncan et al., 2007; La Paro & Pianta, 2000). Key to understanding the basis for SES-related differences in academic achievement during the school years and beyond, therefore, is an understanding of the mechanisms by which SES-related differences in school readiness skills arise prior to children's entry into formal schooling.

Predominant perspectives on SES-related differences in academic achievement conceptualize children as passive recipients of environmental inputs that vary in quality across homes, neighborhoods, and schools (e.g., Bradley & Corwyn, 2002). Such

perspectives fail to take into account the role of genes in the etiology of cognitive development and academic achievement, which research based on twin and adoption studies indicates is quite large (Bouchard & McGue, 1981; Loehlin & Nichols, 1976, McGue, 1997). Only relatively recently have researchers and theorists begun to take seriously the hypothesis that social forces may affect child development in part through the facilitation or inhibition of genes for psychological development. Bronfenbrenner and Ceci (1994), for example, proposed that *proximal processes*, which they defined as high quality reciprocal interactions between children and individuals and objects in their immediate social and physical environments, are necessary for the actualization of their individual genetic potentials for healthy psychological development. Based on this perspective, they predicted (p. 570) that “increased levels of proximal processes,” which, they commented, are more common in higher SES homes, “should lead not only to higher levels of heritability but also to more advanced levels of developmental functioning.” Put differently, if genetic differences between individuals are expected to relate to differences in the extent to which individuals take advantage of environmental opportunities for learning and achievement, then the heritable variation in cognition and achievement outcomes should be expected to be most pronounced for individuals living in contexts that provide the greatest amount of opportunity for learning and achievement.

Recent work has uncovered support for gene \times environment interactions across a wide range of ages and domains of cognitive development (Friend, DeFries, & Olson, 2008; Harden, Turkheimer, & Loehlin, 2007; Rowe, Jacobson, & van den Oord, 1999; Turkheimer, Haley, Waldron, D’Onofrio, & Gottesman, 2003). Evidence for gene \times environment interactions on cognition and achievement in preschool-aged children, however, is mixed. Taylor and Schatschneider (2010) examined the heritability of pre-reading and reading skill in kindergarten and first grade across low, middle, and high-income groups of children, and found that better environments promote greater genetic variance in reading skill in first grade. This interaction was not yet present in kindergarten. Similarly, Taylor et al. (2010) reported that teacher quality in first and second grade moderates the heritability of early reading, in the direction of better teachers being associated with greater heritability of reading skill. Friend et al. (2009) reported a significant interaction effect in the opposite direction for children in kindergarten to second grade; that is, they reported greater heritability of strong reading skill (i.e., reading ability 1 or more standard deviations above the mean) for children whose parents had lower levels of education. This finding was only present in one of two samples they reported (in the second sample, this interaction was significant at sixth grade but not in early childhood), and it is further unclear whether the results would generalize to normal variation in reading skill. Though one study has reported a gene \times environment interaction for mathematics skill in later childhood (Docherty, Kovas, and Plomin, 2010), we are not aware of any research to date that has specifically examined gene \times environment interaction on preschool numerical abilities.

In recent work, Tucker-Drob, Rhemtulla, Harden, Turkheimer, and Fask (2011) found that family SES interacted with genetic influences on mental ability in 2 year olds. Higher SES was associated not only with higher mental ability test scores, but also with greater expression of genes for mental ability. This is the earliest age at which gene \times environment interaction has been detected on cognition to date. The current project aimed to investigate

gene \times environment interactions using this same group of children 2 years later, when they were 4 years old. Early academic achievement in preschool and kindergarten, also known as school readiness, is generally considered foundational for continued academic achievement throughout the school years (Duncan et al., 2007). However, it is currently unknown whether gene \times SES effects exist on early academic achievement, or whether the interaction effects on achievement that have been documented in research on older children only emerge later in development, after more prolonged exposure to socioeconomic disadvantage in scholastic settings. The current project specifically addressed this question by examining whether gene \times SES effects similar to those previously documented on mental ability at 2 years of age are apparent on early school readiness skills (early mathematics and reading skills) in preschool.

After identifying interactions on early school readiness skills, we examined whether they could be attributed to the persistence of the effects previously identified at 2 years of age. There are at least two possible patterns in which SES-related differences in gene-expression can be manifest over time (cf. Phillips, Crouse, & Ralph, 1998). A *persisting disadvantage* model predicts that early SES-related differences would persist and possibly amplify as children proceed through development. A *recurring disadvantage* model predicts that SES-related differences would be apparent throughout childhood because children are recurrently exposed to consistent levels of advantage versus disadvantage throughout development, which have novel, albeit analogous, effects on achievement. Of course, the persisting disadvantage and recurring disadvantage models are not mutually exclusive. SES-related differences in gene expression at a specific point in time can potentially result from a combination of the maintenance or magnification of differences in gene expression that occurred earlier in development *and* the emergence of differences in the expression of genes that are unique to that age. The present study appears to constitute the first comparison of the persisting disadvantage versus recurring disadvantage distinction with respect to gene \times environment interaction.

Method

Participants

The current project was based on 700 pairs of twins (i.e. 1,400 individuals) who participated in the Early Childhood Longitudinal Study-Birth Cohort (ECLS-B).¹ These were all of the twins in the dataset for whom SES information and dependable zygosity information was available, out of a total of 800 pairs. ECLS-B is a nationally representative sample of 14,000 children born in the United States in 2001, and the twin subsample can be assumed to be similarly representative. Informed parental consent was obtained by ECLS-B staff for all study participants. Like the primary ECLS-B sample, the ECLS-B twin subsample is ethnically and economically diverse (61% White, 16% African-American, 16% Hispanic, 3% Asian, 1% Pacific Islander, American Indian, or Alaska Native, and 4% mixed race; 51% male; 25% of twins' families lived below the poverty line at study entry). The current analyses are based on measures taken in 2003–2004, when the twins were approximately 2 years of age, and 2005–2006, when the twins were approximately 4 years of age. Ninety-six

¹Sample sizes are rounded to the nearest 50 in accordance with ECLS-B data security regulations.

percent contributed mental ability data in 2003–2004 and 86% contributed school readiness data in 2005–2006.

Measures

Twin pair zygosity—In addition to parental reports of whether they believe their twins to be identical or fraternal, physical similarity ratings with respect to hair color, hair texture, complexion, facial appearance, and ear lobe shape were made by the twins' parents and by trained observers from the ECLS staff. There is a great deal of evidence to show that zygosity diagnoses based on physical similarity ratings such as these are over 90% accurate when cross-validated against objective indices of zygosity, such as twin-pair genotyping (Forget-Dubois et al., 2003; Goldsmith, 1991). Observers' responses to each feature were coded as 1 (“no difference”), 2 (“slight difference”) or 3 (“clear difference”). Using the procedure reported in Tucker-Drob et al. (2011), we summed the scores for each twin pair, resulting in a bimodal distribution of scores ranging from 6 to 18. Based on the shape of this distribution, twin pairs whose scores fell in the 6–8 range were classified as monozygotic (MZ; ~25%), and all other twin pairs were classified as dizygotic (DZ; ~35% same-sex, 40% opposite-sex). Further, we excluded participants who met our criteria for DZ diagnosis, but whose parents indicated that there was a medical reason for their dissimilarity.

SES—ECLS-B provides an SES index, which is composite of five variables: paternal and maternal education, paternal and maternal occupation, and family income. We used the SES index based on variables measured at the 2 year wave, and *z*-transformed it (mean = 0, SD = 1) prior to analyses. This measure correlated with SES measured at the 4 year wave at .89.

Race/Ethnicity—Race/ethnicity was effects coded as 0.5 = White and –0.5 = Non-White. This dichotomous coding was chosen because there were not enough twin pairs from individual minority groups to confidently estimate effects for each race/ethnicity separately. This variable correlated with SES at .40.

Infant mental ability—When the twins were approximately 2 years of age, ECLS-B staff administered the Bayley Short Form-Research Edition (BSF-R), which is a shortened form of the Bayley Scales of Infant Development, Second Edition (Bayley, 1993). The BSF-R has a mental scale and a motor scale, each of which have been extensively validated using Item Response Theory for measurement invariance, unidimensionality, and discriminant validity relative to one another (Andreassen & Fletcher, 2007). The current project made use of the mental ability scale, which assesses object exploration, early problem solving, sound and gesture production, and receptive and expressive language. This variable was *z*-transformed for the current project. BSF-R scores correlated with SES at .33.

Early reading skill—During the preschool wave children were directly measured on early pre-reading skill using a test composed of 37 items representing the following content areas: letter recognition, knowledge of letter sounds, recognition of simple words, phonological awareness, knowledge of print conventions, and matching words (Najarian, Snow, Lennon, & Kinsey, 2010). A pre-reading skill ability estimate was derived for each child using Item

Response Theory. This variable was z -transformed for the current project. Early reading skill scores correlated with SES at .47, and with infant mental ability at .39.

Early mathematics skill—During the preschool wave children were directly measured on their early mathematics skill using a test composed of 45 items representing the following content areas: number sense, geometry, counting, operations, and patterns (Najarian et al., 2010). A mathematics skill ability estimate was derived for each child using Item Response Theory. This variable was z -transformed for the current project. Early mathematics skill scores correlated with SES at .46, with infant mental ability at .42, and with reading skill at .75.

Analyses and Results

We fit a series of behavioral genetic models using full information maximum likelihood estimation in *Mplus* statistical software (Muthén and Muthén, 1998–2010).

Cross-Sectional Analyses

As a first step we applied classical biometric models for monozygotic and dizygotic twins raised together to decompose variation in each cognitive and school readiness variable (Bayley at 2 years; Mathematics at 4 years; Reading at 4 years) into additive genetic influences (A) that are fully shared among MZ twins and partly shared among DZ twins, shared environmental influences (C) that are experienced by both twins in a pair and serve to make them similar to one another, and non-shared environmental influences (E) that are differentially experienced by each twin in a pair and serve to make them dissimilar from one another. Based on classical genetic theory, the A factors are assumed to be correlated at 1.0 for MZ twins and at .5 for DZ twins. By definition the C factors are correlated at 1.0 and the E factors are uncorrelated across all twin pairs. SES was included as a family-level covariate to control for its main effect on each outcome. This model is written as follows for a given phenotype, Y :

$$Y_{t,p} = s \cdot SES_p + a \cdot A_{t,p} + c \cdot C_{t,p} + e \cdot E_{t,p}, \quad (1)$$

where t = twin, p = twin pair, and s , a , c , and e are regression coefficients representing the main effects of SES, A , C , and E respectively. Note that controlling for the main effect of SES controls for any causal effect of SES on the phenotype as well as any effect of passive gene-environment correlation that results from children inheriting the same characteristics that may have been instrumental in determining their parents' educational, economic, and professional outcomes (Purcell, 2002). Of course, because SES is measured at the family level, it acts statistically as a form of the shared environment.

Next, we expanded the above model to allow the influences of A , C , and E to vary as functions of SES. This model (Purcell, 2002) can be written as follows:

$$Y_{t,p} = (s \cdot SES_p) + (a + a' \cdot SES_p) \cdot A_{t,p} + (c + c' \cdot SES_p) \cdot C_{t,p} + (e + e' \cdot SES_p) \cdot E_{t,p}. \quad (2)$$

where, a' , c' , and e' represent the interaction of SES with A, C, and E, respectively. This model is depicted as a path diagram in Figure 1A. Note that when these parameters are fixed to 0, Model 1b is identical to Model 1a.

Results for mental ability at 2 years—Results from the application of main effects and interaction models to mental ability at age 2 are presented in Table 1, and discussed more fully in Tucker-Drob et al. (2011). Three observations regarding these results are of note: First, a significant main effect of SES ($s=.318$) indicated that children being raised in higher-SES homes display higher mental ability at 2 years than those raised in lower-SES homes. Second, heritability of mental ability at 2 years was 19% ($p<.01$). This coefficient indexes the SES-independent variability in mental ability accounted for by genes as a proportion of the variability in mental ability accounted for by all of the biometric components (A, C, and E). Third, a significant gene \times SES interaction ($a'=.13$, $p<.01$) indicated that higher SES is associated with greater influence of genes on mental ability. A series of chi-square difference tests revealed that the model with the a' interaction term fit significantly better than the main effects only model, $\chi^2(1) = 6.72$, $p = .01$, and the model with all three interaction terms estimated fit no better than the one with only a' estimated, $\chi^2(2) = 2.53$, $p = .28$.

Results for school readiness (mathematics and reading) at 4 years—Results from the application of main effects and interaction models to school readiness at age 4 are presented in Table 2. For both mathematics skill and reading skill, all main effects were significant. SES accounted for 22% of the variance in mathematics skill, and 25% of the variance in reading skill. The population-level heritability of mathematics scores was 33% and the population-level heritability of reading scores was 14%. A significant gene \times SES interaction was evident for mathematics but not reading skill, reflecting that the genetic contribution to mathematics skill was higher for children being raised in higher SES homes. These results are illustrated in Figure 2. At -2 SDs on SES, genes accounted for fewer than .01 units (0%) of variance in mathematics and .13 units (15%) of variance in reading skill; at $+2$ SDs, genes account for .43 units (48%) of variance in mathematics and .08 units (13%) of variance in reading skill.² In other words, at higher levels of SES, both the absolute and the relative contributions of genes to mathematics skill are more pronounced, but there is no evidence that the absolute or relative contributions of genes or environment to reading skill relates to SES. Nested chi-square difference tests revealed that the mathematics skill model with a' estimated fit significantly better than the main effects only model, $\chi^2(1) = 11.52$, $p < .001$, and the model with all three interaction terms estimated fit no better than the one with only a' estimated, $\chi^2(2) = 2.15$, $p = .34$. The reading skill model with all interaction terms estimated did fit significantly better than the main effects model, $\chi^2(3) = 8.77$, $p = .03$, indicating that there was some improvement in fit due to adding the interaction terms. Closer inspection points to the e' term, ($e' = .034$, $p = .057$) which was marginally significant, as the source of improved fit. Though close to significant, this effect is rather small (nonshared

$${}^2 \text{heritability} = \frac{(a+a' \cdot \text{SES})^2}{(a+a' \cdot \text{SES})^2 + (c+c' \cdot \text{SES})^2 + (e+e' \cdot \text{SES})^2}$$

environment accounts for 28% of the variance in reading at -2 SD of SES, and for 20% of its variance at $+2$ SD) and is therefore difficult to interpret.

Sensitivity Analysis—Because low socioeconomic status and racial/ethnic minority status covary substantially in the United States, we ran an additional model to test whether the gene \times SES interaction on mathematics skill could be accounted for by a gene \times race/ethnicity interaction. In this model, the main effects of race/ethnicity and SES as well as the effects of their interaction terms with each biometric component were included. The inclusion of race did not alter the significant gene \times SES interaction, $a' = .143$, 95% $CI = (.019, .266)$, and the race interactions with A, C, and E were not statistically significant. In other words, the gene \times SES interaction on mathematics skill reported above was robust to controls for race/ethnicity.

Longitudinal Analyses

Next we examined whether the interaction observed on mathematics skill at 4 years could be accounted for by those observed on mental ability at 2 years (see Figure 1B). In our longitudinal model, school readiness (SR ; measured by preschool mathematics skill) was regressed onto each of the biometric components of earlier mental ability (MA), and their interactions with SES. In Figure 1B, this is represented by the arrows from biometric components at 2 years (A_{2y} , C_{2y} , E_{2y}) to school readiness at 4 years. The remaining variance in school readiness at 4 years was partitioned into additional biometric components unique to the preschool time point (A_{4y} , C_{4y} , E_{4y}), and their interactions with SES. SES was included as a covariate in the model to remove its main effect from any of the biometric components, and each biometric component was also allowed to interact with SES. This model can be written as:

$$\begin{aligned}
 MA_{2y,t,p} &= s_{2y} \cdot SES_p + (a_{2y} + a'_{2y} \cdot SES_p) \cdot A_{2y,t,p} + (c_{2y} + c'_{2y} \cdot SES_p) \cdot C_{2y,t,p} \\
 &\quad + (e_{2y} + e'_{2y} \cdot SES_p) \cdot E_{2y,t,p} \\
 SR_{4y,t,p} &= s_{4y} \cdot SES_p + (a_b + a'_b \cdot SES_p) \cdot A_{b,t,p} + (c_b + c'_b \cdot SES_p) \cdot C_{b,t,p} \\
 &\quad + (e_b + e'_b \cdot SES_p) \cdot E_{b,t,p} + (a_{4y} + a'_{4y} \cdot SES_p) \cdot A_{4y,t,p} \\
 &\quad + (c_{4y} + c'_{4y} \cdot SES_p) \cdot C_{4y,t,p} + (e_{4y} + e'_{4y} \cdot SES_p) \cdot E_{4y,t,p}
 \end{aligned} \tag{3}$$

A significant a'_b parameter would be consistent with a persisting disadvantage model, in that the interaction between SES and genes apparent at 2 years affects performance at 4 years. A significant a'_{4y} parameter would be consistent with a recurring disadvantage model in that SES interacts with genetic effects at 4 years that were not apparent at 2 years.

Longitudinal model results—Results of the longitudinal analyses of early mathematics skill are presented in Table 3. A number of observations are of note. First, the genes responsible for mathematics skill at 4 years were not the same as those responsible for mental ability at 2 years. Rather, new genes contributed significantly to mathematics skill at 4 years, accounting for 14% of the total variance in mathematics achievement at the population level. Second, there were significant unique contributions of shared and nonshared environment on mathematics skill, after accounting for the shared environment

effects on mental ability at 2 years. Finally, the gene \times SES interaction on mathematics skill was not accounted for by the gene \times SES interaction affecting mental ability at 2 years (i.e. the a'_b term was not significant). That is, SES modified the influence of new genetic variance on mathematics (as indicated by the significant a'_{4y} term) rather than the influence of the genetic variance that affected mental ability at 2 years. Nested chi-square difference tests revealed that the model with a'_{2y} and a'_{4y} estimated fit significantly better than the main effects only model, $\chi^2(2) = 16.35, p < .001$, and the model with all nine interaction terms estimated fit no better than the one with only a'_{2y} and a'_{4y} estimated, $\chi^2(7) = 6.35, p = .50$.

Power Analyses and Results

While we detected a statistically significant gene \times SES interaction for mathematics skill at 4 years, we were unable to detect such an interaction for reading skill at 4 years. We therefore conducted a small simulation to a) investigate whether our sample had sufficient power to detect interaction effects of interest, and b) discover what sample sizes are sufficient for detecting interaction effects that take on a range of values. To do this, we simulated 1000 datasets based on the cross-sectional reading skill model that failed to detect a gene \times SES interaction. The details of our sample were retained in the generated data: the sample size per group, the amount of missing data, and every parameter estimate from that model was set as the generating population value. This analysis revealed that the power to detect the gene \times SES effect that we observed (i.e., $a' = -.018$) was .12. This value is very low, but the effect size was also low enough that it may be deemed to be not of interest.

We followed up with a further set of simulations, in which we kept all of the details of the original simulation constant but varied two features: Sample size ranged from 100 to 1000 twin pairs, and the parameter value a' ranged from .05 to .25. Results of these simulations are given in Figure 3. Conventionally, power of approximately 80% and above is considered adequate. Overall, these results suggest that, when the sample characteristics and parameters otherwise resemble those observed for the reading skills outcome, a sample size of approximately 750 pairs would be adequately powered to detect a gene \times environment interaction of magnitude $a' = .20$. For smaller magnitude gene \times environment interactions, samples in excess of 1000 pairs would be necessary to achieve 80% power under these conditions. Therefore, the results from our empirical analyses can be taken to indicate that a very large gene \times SES interaction on early reading skill is improbable, but should not be taken as evidence against the existence of smaller gene \times SES interactions on early readings skill. It is important to note that these power estimates may not apply to other conditions, such as those in which the main effects of genes are higher. Here, reading was only 14% heritable at the population level.

Discussion

We examined the genetic and environmental influences on school readiness in preschool-aged children, measured by their early mathematics and reading skills. Cross-sectional models decomposed the variance in each of these skills into their genetic, shared and nonshared environmental components, and examined the interactions of each of these

components with SES. Genetic influences on mathematics, but not reading skill, were larger for children raised in higher SES families, suggesting that genes for early mathematics skill are more strongly expressed in higher SES contexts. The cross-sectional models were followed by a longitudinal model that decomposed genetic and environmental influences on mathematics skill at 4 years into those shared with genetic and environmental influences on mental ability at 2 years, and those independent of mental ability at 2 years. The gene \times SES interaction on mathematics skill that emerged from the cross-sectional model remained significant. Supporting a *recurring disadvantage* model, this interaction occurred exclusively on genetic contributions to mathematics skill that were independent of mental ability at two years.

The gene \times environment interaction observed on early mathematics skill is consistent with proposals (Bronfenbrenner & Ceci, 1994; Turkheimer & Gottesman, 1991) that the expression of genes for cognitive development is dependent on the quality of the larger environmental context in which children are situated. Why was there no gene \times environment interaction apparent on reading skill? One possibility relates to findings that reading skill represents a heterogeneous array of more specialized functions. Byrne et al. (2002), for example, examined young children's performance on 25 distinct tasks related to early literacy skill. While some of these tasks (e.g., rapid color naming, story learning, verbal working memory) were highly heritable, many of the tasks (e.g., letter and phoneme recognition, print conventions) had no significant heritability and were instead strongly influenced by shared environmental factors. In the present study, early reading was assessed using tasks very similar to the ones that Byrne et al. found to have low heritability (e.g., recognition of letters and words, print conventions). Indeed, we found the heritability of reading to be 14.3%, indicating a significant but relatively small effect of genes. In contrast, the effect of shared environment was 62.2%, and nonshared environment (in combination with measurement error) contributed the remaining 23.4%. It is possible that because genetic influences on this measure were rather small, any gene \times environment interaction effects that were present would have also been very small in magnitude, and hence difficult to detect.

It is also possible that gene \times environment effects on early reading only emerge in elementary school once children have been exposed to a more prolonged period of inequality in their scholastic experiences, and at a period of development in which a majority of children transition from pre-literacy to literacy. A related possibility is that SES may not be the most appropriate index of environmental quality with respect to academic achievement; for example, indices of school quality may be more appropriate. Taylor et al. (2010) reported that among elementary school children genetic expression for reading skill was positively moderated by teacher quality, indicating that the mechanisms leading to differential expression of genes for reading may depend on classroom-level rather than family-level processes. Of course, a complete picture of how genes and environments interact to produce cognitive development and academic achievement will require the measurement of multiple aspects of cognitive functioning and academic achievement across a wide range of ages in children residing in a variety of different socioeconomic and educational contexts.

That the interaction on mathematics skill observed at age 4 could not be accounted for by variation observed on mental ability at age 2 lends initial support to a *recurring disadvantage*

model of gene \times environment interaction on cognitive development; that is, the genes that interacted with SES to impact mathematics skill at 4 years were different from those that interacted with SES to impact mental ability at 2 years. This result suggests that gene \times SES effects observed at 4 years do not simply represent a carry-over of interactions that occurred earlier on in development. Rather than being a unitary phenomenon, gene \times SES effects may represent interactions with multiple sets of genes for a variety of cognitive functions occurring during multiple periods of development.

Previous studies have found substantial interdependency between cognitive development and academic achievement, with a number reporting strong shared genetic influences between children's cognitive ability and their mathematics ability during middle and late childhood (Alarcón, Knopik, & DeFries, 2000; Hart, Petrill, Thompson, & Plomin, 2009; Kovas, Harlaar, Petrill, & Plomin, 2005), and reading ability (Cardon, DiLalla, Plomin, DeFries, & Fulker, 1990; Harlaar, Hayiou-Thomas, Plomin, 2005; Light, DeFries, & Olson, 1998; Wainwright, Wright, Geffen, Geffen, Luciano, & Martin, 2004). In contrast, the current study, which was based on a much earlier developmental period, found very little genetic overlap between mental ability in infancy and mathematics skill two years later. This may suggest that shared genetic influences on general cognitive ability and mathematics ability only arise later in development. It is of note that the population-average heritability estimates of school readiness skills in the current sample (in the .20 range) were much smaller than those typically observed for achievement in adolescent and adult samples (in the .50+ range), which is likely to be attributable to the well-established finding that genetic variation in cognition and achievement outcomes continuously increases with childhood age (Haworth et al., 2010). It may indeed be the case that patterns of common genetic influences across domains may not arise until later in development, when heritable variation becomes more substantial. Such an outcome would be consistent with Dickens' (2007) model of cognitive development, which suggests that shared genetic influences across cognitive domains arise and strengthen over the course of development through dynamic feedback processes between children and their environments.

While the current study makes considerable progress in identifying gene \times environment interactions in school readiness, a number of outstanding questions should be addressed in future research. One primary question, of particular relevance to public policy and intervention, is what specific aspects of SES serve to promote the expression of genes for school readiness. While SES was operationally formed as a composite of parental education, parental income, and parental job prestige, it is likely to serve as a surrogate marker for a host of other aspects of the physical, social, and educational environment. Second, it will be important to identify aspects of child behaviors that serve as mechanisms for the expression of genes. If, as we hypothesize, the interactions observed here result from differences in the efficiency of dynamic feedback processes in which children's genetically-influenced temperaments, interests, and motivations lead them to seek out and evoke varying levels of environmental stimulation, we should expect specific aspects of child personality and temperament to be more tightly coupled to academic outcomes in higher opportunity environments. Finally, using the longitudinal methods introduced here, it will be important to examine whether gene \times environment interactions on school-readiness skills can account for gene \times environment interactions on academic achievement in middle school and high

school. This will be important for addressing the question of whether SES-related differences in late childhood and adolescence represent a persistence of differences that occurred at school entry.

In conclusion, we found that genetic influences on early mathematics skill but not early reading skill were larger for children being raised in higher SES families. These interactions could not be attributed to interactions occurring on mental development 2 years earlier, suggesting that SES relates to the differential expression of multiple genetic and environmental influences on multiple functions at multiple periods of early childhood development.

Acknowledgments

Preparation of this article was supported by National Institutes of Health grant R21 HD069772 to E.M. Tucker-Drob and a Banting Postdoctoral Fellowship to M. Rhemtulla. EMTD is a faculty research associate at the Population Research Center at the University of Texas at Austin, which is supported by National Institutes of Health center grant R24 HD042849. The analyses presented here use data from the ECLS-B data file, which was provided by the U.S. Department of Education National Center for Education Statistics.

References

- Alarcón M, Knopik VS, DeFries JC. Covariation of mathematics achievement and general cognitive ability in twins. *Journal of School Psychology*. 2000; 38:63–77.
- Andreassen, C.; Fletcher, P. Early Childhood Longitudinal Study, Birth Cohort (ECLS–B) Psychometric Report for the 2-Year Data Collection (NCES 2007–084). U.S. Department of Education; Washington, DC: 2007.
- Bayley, N. Bayley Scales of Infant Development, Second Edition. San Antonio, TX: The Psychological Corporation; 1993.
- Bouchard TJ, McGue M. Familial studies of intelligence: A review. *Science*. 1981; 212:1055–1059. [PubMed: 7195071]
- Bradley RH, Corwyn RF. Socioeconomic status and child development. *Annual Review of Psychology*. 2002; 53:371–399.
- Bronfenbrenner U, Ceci SJ. Nature-nurture reconceptualized in developmental perspective: A bioecological model. *Psychological Review*. 1994; 101:568–586. [PubMed: 7984707]
- Byrne B, Delaland C, Fielding-Barnsley R, Quain P, Samuelsson S, Høien T, ... Olson RK. Longitudinal twin study of early reading development in three countries: Preliminary results. *Annals of Dyslexia*. 2002; 52:49–73.
- Cardon LR, DiLalla LF, Plomin R, DeFries JC, Fulker DW. Genetic correlations between reading performance and IQ in the Colorado Adoption Project. *Intelligence*. 1990; 14:245–257.
- Dickens, WT. Working Paper. The Brookings Institution; 2007. What is g?. Downloaded 12/10/10 from http://www.brookings.edu/~media/Files/rc/papers/2007/0503education_dickens/20070503.pdf
- Docherty SJ, Kovas Y, Plomin R. Gene-environment interaction in the etiology of mathematical ability using SNP sets. *Behavior Genetics*. in press.
- Duncan GJ, Dowsett CJ, Claessens A, Magnuson K, Huston AC, Klebanov P, ... Japel C. School readiness and later achievement. *Developmental Psychology*. 2007; 43:1428–1446. [PubMed: 18020822]
- Duncan GJ, Yeung WJ, Brooks-Gunn J, Smith JR. How much does poverty affect the life chances of children? *American Sociological Review*. 1998; 63:406–423.
- Feinstein L. Inequality in the early cognitive development of British children in the 1970 cohort. *Economica*. 2003; 70:73–98.
- Forget-Dubios N, Pérusse D, Turecki G, Girard A, Billette J, Rouleau G, ... Tremblay R. Diagnosing zygosity in infant twins: physical similarity, genotyping, and chorionicity. *Twin Research and Human Genetics*. 2003; 6:479–485.

- Friend A, DeFries JC, Olson RK. Parental Education moderates genetic influences on reading disability. *Psychological Science*. 2008; 19:1124–1130. [PubMed: 19076484]
- Friend A, DeFries JC, Olson RK, Pennington B, Harlaar N, Byrne B, ... Keenan JM. Heritability of high reading ability and its interaction with parental education. *Behavior Genetics*. 2009; 39:427–436. [PubMed: 19296213]
- Goldsmith HH. A zygosity questionnaire for young twins: A research note. *Behavior Genetics*. 1991; 21:257–269. [PubMed: 1863259]
- Harden KP, Turkheimer E, Loehlin JC. Genotype by environment interaction in adolescents' cognitive aptitude. *Behavior Genetics*. 2007; 37:273–283. [PubMed: 16977503]
- Harlaar N, Hayiou-Thomas ME, Plomin R. Reading and general cognitive ability: A multivariate analysis of 7-year-old twins. *Scientific Studies of Reading*. 2005; 9:197–218.
- Hart SA, Petrill SA, Thompson LA, Plomin R. The ABCs of math: A genetic analysis of mathematics and its links with reading ability and general cognitive ability. *Journal of Educational Psychology*. 2009; 101:388–402. [PubMed: 20157630]
- Haworth CMA, Wright MJ, Luciano M, Martin NG, de Geus EJC, van Beijsterveldt CEM, ... Plomin R. The heritability of general cognitive ability increases linearly from childhood to young adulthood. *Molecular Psychiatry*. 2010; 15:1112–1120. [PubMed: 19488046]
- Kovas Y, Harlaar N, Petrill SA, Plomin R. 'Generalist genes' and mathematics in 7-year-old twins. *Intelligence*. 2005; 33:473–489. [PubMed: 19319204]
- La Paro KM, Pianta RC. Predicting children's competence in the early school years: A meta-analytic review. *Review of Educational Research*. 2000; 70:443–484.
- Loehlin, JC.; Nichols, RC. *Heredity, environment, and personality: A study of 850 sets of twins*. Austin, TX: University of Texas Press; 1976.
- Leseman PPM, de Jong PF. Home literacy: Opportunity, instruction, cooperation and social-emotional quality predicting early reading achievement. *Reading Research Quarterly*. 1998; 33:294–318.
- Light JG, DeFries JC, Olson RK. Multivariate behavioral genetic analysis of achievement and cognitive measures in reading-disabled and control twin pairs. *Human Biology*. 1998; 70:215–237. [PubMed: 9549237]
- McGue M. The democracy of the genes. *Nature*. 1997; 388:417–418. [PubMed: 9242394]
- Muthén, BO.; Muthén, L. *MPlus user's guide*. 6. Los Angeles, CA: Muthén and Muthén; 1998–2010.
- Najarian, M.; Snow, K.; Lennon, J.; Kinsey, S. *Early Childhood Longitudinal Study, Birth Cohort (ECLS-B), Preschool–Kindergarten 2007 Psychometric Report (NCES 2010-009)*. U.S. Department of Education; Washington, DC: 2010.
- Phillips, M.; Crouse, J.; Ralph, J. Does the Black-White test score gap widen after children enter school?. In: Jencks, C.; Phillips, M., editors. *The Black-White Test Score Gap*. Washington, DC: Brookings Institution Press; 1998. p. 229-272.
- Price TS, Freeman B, Craig I, Petrill SA, Ebersole L, Plomin R. Infant zygosity can be assigned by parental report questionnaire data. *Twin Research*. 2000; 3:129–133. [PubMed: 11035484]
- Purcell S. Variance components models for gene-environment interaction in twin analysis. *Twin Research*. 2002; 5:554–571. [PubMed: 12573187]
- Rowe DC, Jacobson KC, Van den Oord EJCG. Genetic and environmental influences on vocabulary IQ: Parental education level as moderator. *Child Development*. 1999; 70:1151–1162. [PubMed: 10546338]
- Taylor J, Roehrig AD, Hensler BS, Connor CM, Schatschneider C. Teacher quality moderates the genetic effects on early reading. *Science*. 2010; 328:512–514. [PubMed: 20413504]
- Taylor J, Schatschneider C. Genetic influence on literacy constructs in kindergarten and first grade: Evidence from a diverse twin sample. *Behavior Genetics*. 2010; 40:591–602. [PubMed: 20563747]
- Tucker-Drob EM, Rhemtulla M, Harden KP, Turkheimer E, Fask D. Emergence of a gene-by-socioeconomic status interaction in infant mental ability from 10 months to 2 years. *Psychological Science*. 2011; 22:125–133. [PubMed: 21169524]
- Turkheimer E, Haley A, Waldron M, D'Onofrio B, Gottesman I. Socioeconomic status modifies heritability of IQ in young children. *Psychological Science*. 2003; 14:623–628. [PubMed: 14629696]

- Turkheimer E, Gottesman II. Individual differences and the canalization of human behavior. *Developmental Psychology*. 1991; 27:18–22.
- Wadsworth SJ, DeFries JC, Fulker DW, Plomin R. Covariation among measures of cognitive ability and academic achievement in the Colorado Adoption Project: Sibling analysis. *Personality and Individual Differences*. 1995; 18:63–73.
- Wainwright M, Wright MJ, Geffen GM, Geffen LB, Luciano M, Martin NG. Genetic and environmental sources of covariance between reading tests used in neuropsychological assessment and IQ subtests. *Behavior Genetics*. 2004; 34:365–376. [PubMed: 15082934]

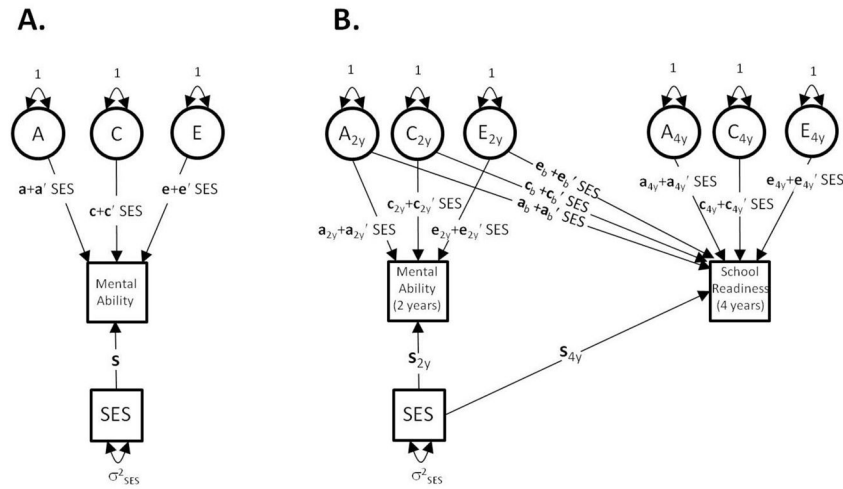

Figure 1. Panel A (left): Cross-sectional Gene × Environment Model. This model tests for a gene × environment interaction on a phenotype (e.g. mental ability at a single point in time). Panel B (right): Longitudinal Gene × Environment Interaction Model. This model can be used to test whether gene × environment interaction on school readiness at 4 years can be accounted for by gene × environment interaction on mental ability at 2 years. In both panels, for ease of presentation, only one twin per pair is represented.

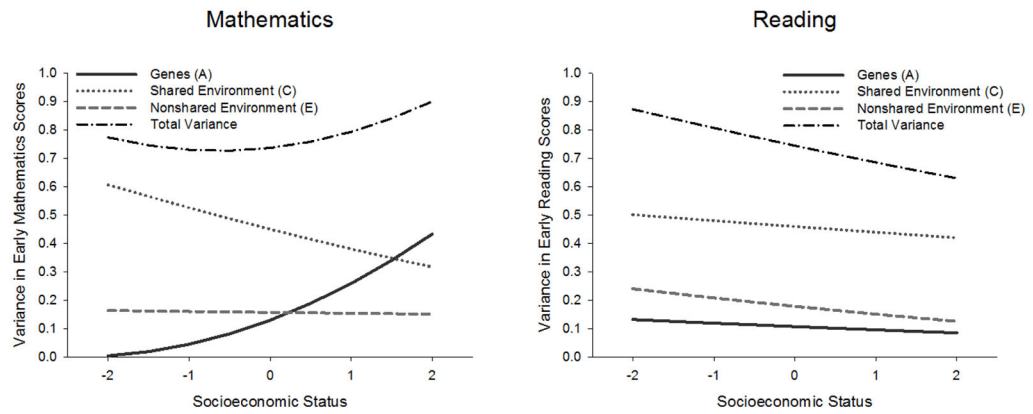

Figure 2. Amounts of unstandardized variance in early mathematics skill (left), and early reading skill (right) accounted for by genes (A), the shared environment (C), and the nonshared environment (E), as functions of SES. Total variance reflects the sum of the variance accounted for by A, C, and E, as a function of SES. SES, Early Mathematics Scores, and Early Readings Scores were z-transformed prior to analyses.

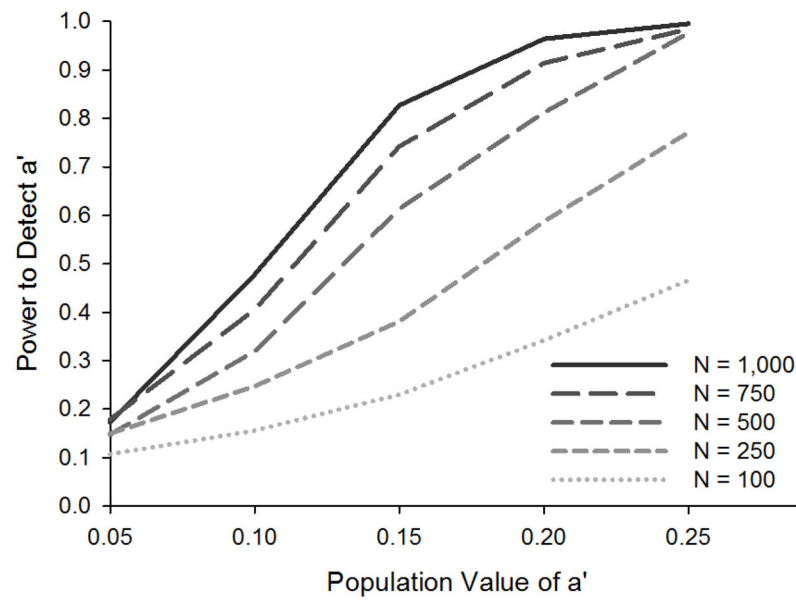

Figure 3. Observed power to detect a range of gene \times SES interaction values given a range of sample sizes (N = number of twin pairs). All generating model parameters (apart from a') are identical to the parameter estimates found for the reading skill interaction model presented in Table 2.

Table 1

Unstandardized Parameter Estimates from Cross-Sectional Models of Mental Ability at 2 Years

Parameter	Main Effects		Interaction	
	Estimate	95% CI	Estimate	95% CI
<i>a</i>	0.402	(.257, .547)	0.395	(.268, .522)
<i>a'</i>			0.132	(.046, .218)
<i>c</i>	0.678	(.598, .758)	0.672	(.596, .748)
<i>c'</i>			-0.021	(-.097, .055)
<i>e</i>	0.466	(.419, .513)	0.451	(.410, .492)
<i>e'</i>			-0.026	(-.059, .007)
<i>s</i>	0.318	(.253, .383)	0.317	(.250, .384)
<i>LL</i>	-2436.5		-2431.9	
<i>parameters</i>	5		8	

Note. The *Main Effects Model* decomposed variation in mental ability at 2 years into effects of genes (*a*), shared environment (*c*), nonshared environment (*e*), and SES (*s*). The *Interaction Model*, depicted in Figure 1B, additionally allowed for interactions between each biometric component and SES (*a'*, *c'*, *e'*). Bolded parameters are significant at $p < .05$. *LL* is the value of the loglikelihood function for each model, and *Parameters* is the number of model parameters that were estimated.

Unstandardized Parameter Estimates from Cross-Sectional Models of Early Reading Skill and Early Mathematics Skill at 4 Years

Table 2

Parameter	Main Effects Models				G×E Interaction Models			
	Mathematics ("M" subscript)		Reading ("R" subscript)		Mathematics ("M" subscript)		Reading ("R" subscript)	
	Estimate	95% CI	Estimate	95% CI	Estimate	95% CI	Estimate	95% CI
<i>a</i>	.439	(.327, .551)	.304	(.147, .461)	.360	(.229, .491)	.327	(.170, .484)
<i>a'</i>			.149	(.057, .241)	.149	(.057, .241)	-.018	(-.128, .092)
<i>c</i>	.646	(.568, .724)	.679	(.608, .750)	.671	(.597, .745)	.678	(.602, .754)
<i>c'</i>			-.054	(-.128, .020)	-.054	(-.128, .020)	-.015	(-.082, .052)
<i>e</i>	-.399	(-.442, -.356)	-.417	(-.462, -.372)	.396	(.437, .355)	.422	(-.469, -.375)
<i>e'</i>			-.004	(-.037, .029)	-.004	(-.037, .029)	-.034	(-.069, .001)
<i>s</i>	.461	(.396, .526)	.483	(.421, .546)	.466	(.399, .533)	.480	(.417, .543)
<i>LL</i>	-1346.5		-1315.1		-1339.6		-1310.7	
<i>Parameters</i>	5		5		8		8	

Note. The *a*, *c*, and *e* parameters reflect the main effects of genes, shared environment, and nonshared environment, respectively. The corresponding interaction terms (*a'*, *c'*, *e'*) reflect the interaction of each biometric component with SES. The parameter *s* reflects the main effect of SES. Bolded parameters are significant at $p < .05$. LL is the value of the loglikelihood function for each model, and Parameters is the number of model parameters that were estimated.

Table 3
Unstandardized Parameter Estimates from Longitudinal Models of Mental Ability at 2 Years and Mathematics at 4 Years

Parameter	Mental Ability ("2y" subscript)		Mental Ability → Mathematics ("b" subscript)		Mathematics, Mental Ability ("4y" subscript)	
	Estimate	95% CI	Estimate	95% CI	Estimate	95% CI
<i>a</i>	.449	(.329, .569)	.046	(-.121, .213)	.380	(.258, .502)
<i>a'</i>	.137	(.055, .219)	.073	(-.043, .189)	.109	(.019, .199)
<i>c</i>	.659	(.581, .737)	.297	(.189, .405)	.594	(.514, .674)
<i>c'</i>	-.038	(-.114, .038)	-.028	(-.128, .072)	-.030	(-.108, .048)
<i>e</i>	.454	(.411, .497)	.088	(.031, .145)	.389	(.348, .430)
<i>e'</i>	-.028	(-.061, .005)	-.005	(-.050, .040)	-.003	(-.040, .034)
<i>s</i>	.335	(.270, .400)			.480	(.417, .543)
<i>LL</i>	-2806.33					
Parameters	22					

Note. *Mental Ability* refers to the total A, C, and E effects on mental ability scores at 2 years. *Mental Ability* → *Mathematics* refers to the regression of Mathematics at 4 years on the A, C, and E components of mental ability at 2 years. *Mathematics*, *Mental Ability* refers to the unique A, C, and E effects on Mathematics at 4 years. The *a*, *c*, and *e* parameters reflect the main effects of genes, shared environment, and nonshared environment, respectively. The corresponding interaction terms (*a'*, *c'*, *e'*) reflect the interaction of each biometric component with SES. The parameter *s* reflects the main effect of SES. Bold parameters are significant at $p < .05$. LL is the value of the loglikelihood function for each model, and Parameters is the number of model parameters that were estimated.