

Expression of human factor IX in rat capillary endothelial cells: Toward somatic gene therapy for hemophilia B

SHOU-NAN YAO*, JAMES M. WILSON†, ELIZABETH G. NABEL†, SUMIKO KURACHI*, HARUMI L. HACHIYA†, AND KOTOKU KURACHI*‡

Departments of *Human Genetics and †Internal Medicine, University of Michigan Medical School, Ann Arbor, MI 48109-0618

Communicated by James V. Neel, June 12, 1991

ABSTRACT In aiming to develop a gene therapy approach for hemophilia B, we expressed and characterized human factor IX in rat capillary endothelial cells (CECs). Moloney murine leukemia virus-derived retrovirus vectors that contain human factor IX cDNA linked to heterologous promoters and the neomycin-resistant gene were constructed and employed to prepare recombinant retroviruses. Rat CECs and NIH 3T3 cells infected with these viruses were selected with the neomycin analogue, G418 sulfate, and tested for expression of factor IX. A construct with the factor IX cDNA under direct control by long terminal repeat gave the highest level of expression (0.84 and 3.6 μg per 10^6 cells per day for CECs and NIH 3T3 cells, respectively) as quantitated by immunoassays as well as clotting activity assays. A single RNA transcript of 4.4 kilobases predicted by the construct and a recombinant factor IX of 68 kilodaltons identical to purified plasma factor IX were found. The recombinant human factor IX produced showed full clotting activity, demonstrating that CECs have an efficient mechanism for posttranslational modifications, including γ -carboxylation, essential for its biological activity. These results, in addition to other properties of the endothelium, including large number of cells, accessibility, and direct contact with the circulating blood, suggest that CECs can serve as an efficient drug delivery vehicle producing factor IX in a somatic gene therapy for hemophilia B.

Hemophilia B, an X chromosome-linked recessive disorder, is caused by the deficiency of biologically active factor IX, with a frequency of about 1 in 30,000 general population. Currently, patients are treated by protein replacement therapy by employing purified factor IX or factor IX concentrates prepared from pooled, normal human plasma (1–3). This therapy is effective for treatment of bleeding episodes. However, it may expose patients to various side effects, including contraction of pathogenic viruses such as human immunodeficiency virus type 1 and hepatitis, as well as occasional thrombosis and disseminated intravascular coagulation. Recombinant factor IX preparations may be much safer compared to the plasma factor IX preparation, although its mass production has not yet been accomplished (3). Furthermore, these preparations need to be frequently administered to patients in therapy, causing significant inconveniences and problems.

Somatic cell gene therapy may provide a novel, alternative treatment for hemophilia B, alleviating most of these problems (4, 5). If the plasma concentration level of factor IX supplied by a gene therapy can be maintained at a level as high as 10–20% of the normal, the disorder can be effectively changed from a severe to a mild or phenotypically normal state (2). In considering the development of an optimized approach for the somatic cell gene therapy of hemophilia B, we must address several important issues. These include the

choice of an optimal target cell(s) and the method of transferring the factor IX gene into the tissue where normal factor IX molecules can be produced at a high level and efficiently transported into the circulation. Stable production of the fully active factor IX for a long period of time without any significant deleterious effects is another important issue. Furthermore, because factor IX is one of the several vitamin K-dependent coagulation proteins that require γ -carboxylation in addition to other posttranslational modifications for their biological activity, the capability of the cells to efficiently carry out this unique modification on the newly synthesized polypeptide chains is particularly important. To date, several cell types have been tested as potential target cells for factor IX gene therapy. Skin fibroblast cells have been shown to be a potential tissue to produce factor IX (6–9) and have been tested in animal models (7, 8). Other cells in culture, such as rabbit primary hepatocytes (10), have also been tested for their potential to produce factor IX for the therapy.

Endothelial cells (ECs) (about 10^{12} in number), which are in direct contact with the bloodstream and cover almost 1000 m^2 of the inner surface of blood vessels (11), appear to be very attractive target cells that may satisfy most of the requirements for factor IX gene therapy. Recently, the potential of large vessel ECs to produce heterologous proteins has been described (12, 13). A brief study was also reported showing that bovine adrenocortical ECs can produce canine factor IX with a specific activity of 83% (9).

In this report, we describe the expression and detailed characterization of fully active human factor IX produced in well-defined capillary ECs (CECs). These results provide the basis and rationale to employ CECs as a primary target tissue for producing sufficient factor IX *in vivo* in a gene therapy approach for hemophilia B.

MATERIALS AND METHODS

Materials. Restriction enzymes and DNA modification enzymes were obtained from Boehringer Mannheim. [α - ^{32}P]dCTP was obtained from Amersham. A well-characterized mouse monoclonal antibody against human factor IX (HFIX α 40) was generously provided by W. R. Church (Specialized Center of Research in Thrombosis, University of Vermont). Factor IX-deficient human plasma was purchased from George King Biomedical (Overland Park, KS). The Histostain-sp kit was purchased from Zymed. Vitamin K₁ (2-methyl-3-phytyl-1,4-naphthoquinone) was from Merck Sharp & Dome. Insoluble protein A (*Staphylococcus aureus* membranes) and Polybrene were obtained from Sigma.

Abbreviations: EC, endothelial cell; CEC, capillary EC; BCS, bovine calf serum; Mo-MLV, Moloney murine leukemia virus; LTR, long terminal repeat.

‡To whom all reprint requests should be addressed.

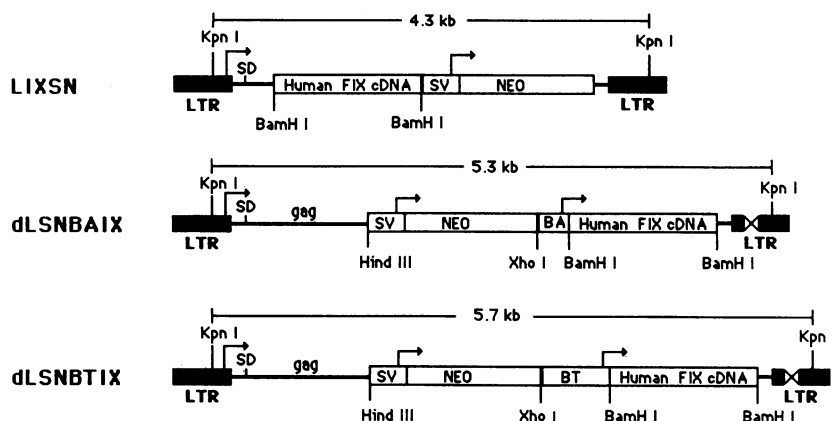

FIG. 1. Structure of Mo-MLV-derived retrovirus vectors employed to express human factor IX. Each vector differs in the transcriptional elements used to drive the expression of factor IX. X marks in the LTRs of two vectors indicate the deletion of the viral enhancer contained in a *Pvu* II/*Xba* I fragment of about 178 bp in the 3' LTR. SD, splice donor site; arrows above each vector show the sites of transcription. Fat lines connecting various components indicate the sequence of Mo-MLV. See text for the details of the construction.

Cells. The CECs isolated from epididymal fat tissues of Sprague-Dawley rats have been well characterized for their homogeneity in morphology, presence of angiotensin-converting enzyme activity, and positive uptake of acetylated low density lipoprotein and have been previously used successfully (14). In the present study, CECs of early passage numbers (4–10 passages) were used. The CECs were grown in Dulbecco's modified Eagle's medium (DMEM) added with Hepes (25 mM) and 5% bovine calf serum (BCS) in gelatin-coated culture dishes. BCS used in the culture was first depleted of the intrinsic bovine factor IX along with other vitamin K-dependent proteins as follows. Two hundred milliliters of BCS was treated with 20 g of barium sulfate at 4°C for 30 min under gentle mixing; this was followed by centrifugation at 3000 rpm for 10 min. The supernatant was passed through a 0.22- μ m filter and added to DMEM. The resulting serum was fully active in supporting cell growth, whereas no detectable factor IX was present, as assayed by the one-stage clotting assay (see below). The use of the treated BCS allowed us to precisely quantitate the human factor IX produced by the transduced cells. NIH 3T3 cells, ψ -2 cells, and ψ CRIP cells were also cultured in DMEM supplemented with 10% of the factor IX-depleted BCS.

Construction of Recombinant Retrovirus Vectors. All vectors are derivatives of Moloney murine leukemia virus (Mo-MLV). The construct, LIXSN, which contains the human factor IX cDNA sequence in such a way that the long terminal repeat (LTR) directly controls its expression and the simian virus 40 promoter linked to the neomycin-resistance gene, was prepared from previously described retrovirus vectors, pEMO (15) and pSVN (16), and a factor IX expression vector, FIX/pD2 (17). pEMO vector DNA was digested with *Bam*HI and *Eco*RI, generating 1.4- and 5.8-kilobase (kb) fragments. The *Bam*HI/*Eco*RI fragment (1.4 kb) containing the 3' LTR of pEMO was subcloned by ligating it between the *Bam*HI and *Eco*RI sites of pUC19. The pUC19 was then cleaved at the unique *Bam*HI site and blunt-ended with mung bean nuclease, destroying the *Bam*HI site, followed by religation. The 1.4-kb fragment inserted was recovered by digestion with *Sal*I and *Eco*RI. The *Sal*I/*Eco*RI fragment was then ligated to the other *Bam*HI/*Eco*RI fragment (5.8 kb), which contains the 5' half of the retrovirus sequence and most of the plasmid vector sequence, and also to a *Bam*HI/*Xho*I fragment (1.7 kb) derived from pSVN containing the simian virus 40 promoter linked to the neomycin-resistance gene (neomycin phosphotransferase gene) (*neo*^r). Ligation of the three fragments generated a plasmid vector, pLSN. The human factor IX cDNA insert derived as a *Bam*HI fragment (1.4 kb) from FIX/pD2 (17) was then inserted into the unique *Bam*HI site of pLSN. The resulting construct was used to produce the recombinant retrovirus, LIXSN. The factor IX cDNA fragment used contained a linker sequence that provided a *Bam*HI site at the 5' end, the entire coding region (the

prepro leader sequence of 46 amino acid residues and the mature protein of 415 amino acid residues), a stop codon, and a small portion [about 50 base pairs (bp)] of the adjacent 3' untranslated region, as described (17).

An expression vector, dLSNBNTIX, containing β -tubulin promoter was constructed from a vector, pSVN (16), which contains *neo*^r, and pBT, which contains human β -tubulin promoter in a retrovirus vector with a 178-bp deletion in the U3 region of its 3' LTR (18). pBT was digested with *Xba*I and *Xho*I to generate two *Xba*I/*Xho*I fragments (1.7 kb and 7 kb). The 1.7-kb fragment, which contains most of the 5' half of the retrovirus sequence, was inserted into pUC19 between the *Xba*I and *Sal*I (compatible with *Xho*I) sites in the polylinker. The *Xba*I/*Hind*III fragment (1.7 kb) was then isolated and ligated together with the *Xba*I/*Xho*I fragment (7.0 kb) obtained from pBT and a *Xho*I/*Hind*III fragment (1.7 kb) containing the simian virus 40 promoter linked to the neomycin-resistance gene that was derived from pSVN (16), generating pLSNBNTIX (10.4 kb). A *Bam*HI fragment containing human FIX cDNA prepared from FIX/pD2 was inserted into the unique *Bam*HI site at the 3' end of the β -tubulin promoter, generating dLSNBNTIX. dLSNBAIX containing mouse β -actin promoter in place of β -tubulin promoter was constructed in a similar fashion using β -actin promoter sequence derived from a retrovirus vector, BA-LDLR (18). Among these constructs, only LIXSN had a shortened packaging sequence (about 400 bp), whereas others had an extended packaging sequence (1.4 kb), including a part of the *gag* sequence.

Preparation of Retroviruses and Infection of Cells. The amphotropic retroviruses of dLSNBAIX and dLSNBNTIX were prepared by transfecting vector DNA into packaging cells, ψ CRIP (19), with the calcium phosphate precipitation method (20). The LIXSN retrovirus was prepared by transfecting vector DNA, LIXSN, into the ecotropic packaging cell line, ψ -2 (21), and infecting amphotropic ψ CRIP cells with the second-day medium from the transfected cells. The

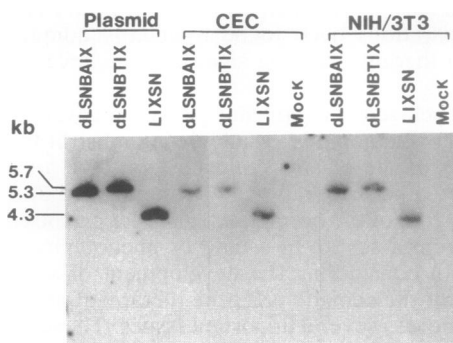

FIG. 2. DNA blot analysis of virus-infected cells. Each lane contains 10 μ g of cellular DNA prepared from cells infected with various retroviruses or from noninfected cells (mock controls).

infected ψ CRIP cells were then selected with G418 (1 mg/ml) for 10–14 days, and 25 resistant colonies for each construct were isolated and expanded into large cultures. The recombinant viruses produced by each individual clone were titered on NIH 3T3 cells as described (22). Rat CECs or NIH 3T3 cells (about 1×10^6 cells) were infected overnight with recombinant retrovirus stock (10 ml) in the presence of 8 μ g of Polybrene per ml and selected in the medium containing 1 mg of G418 per ml for 10–14 days. Cells were split twice during the selection as they reached to confluency. G418-resistant colonies for each construct were pooled and further grown to make the culture stocks. All expression experiments were carried out with these G418-resistant cells in DMEM supplemented with the factor IX-depleted BCS and vitamin K (10 μ g/ml). The clone size of G418-resistant cells used in these experiments was $\geq 10^4$.

Enzyme-Linked Immunosorbent Assay (ELISA) of Human Factor IX. The human factor IX secreted into the cell medium was quantitated by ELISA as follows. Ninety-six-well microtiter plates (Nunc) were coated with 100 μ l of mouse monoclonal antibody (1.35 μ g/ml) against human factor IX (HFIX α 40) in 0.1 M sodium carbonate (pH 9.6) at 4°C overnight. The wells were washed three times with phosphate-buffered saline (PBS: 4.3 mM Na₂HPO₄/1.4 mM KH₂PO₄/2.7 mM KCl/113 mM NaCl) containing 0.05% Tween 20; this was followed by blocking with 200 μ l of PBS, pH 7.2/0.25% bovine serum albumin/0.05% Tween 20 at room temperature for 1 hr. The wells were then washed three

times with PBS/Tween 20 and added to 100 μ l of sample diluted in PBS/0.25% bovine serum albumin/0.05% Tween 20, followed by incubation at room temperature for 2 hr. Human factor IX antigen bound to the monoclonal antibody was detected by employing affinity-purified polyclonal rabbit anti-human factor IX IgG, peroxidase-conjugated goat anti-rabbit IgG (Bio-Rad), and 2,2'-azinobis(3-ethylbenzothiazoline-6-sulfonic acid) as the peroxidase substrate.

Clotting Activity of Factor IX. Factor IX activity was determined by the one-stage clotting assay employing human factor IX-deficient plasma (20). Normal human plasma pooled from 30 healthy individuals who showed normal blood clotting parameters was used as a standard for ELISA and the clotting assay. In calculation, 5 μ g of factor IX per ml of the normal plasma was assumed (23).

Barium Precipitation of Factor IX. Conditioned culture medium was treated with barium citrate to precipitate factor IX with appropriate γ -carboxylation. Briefly, sodium citrate (14 mg) and 1 M barium chloride (95 μ l) was added to 2 ml of medium and incubated with gentle mixing at 4°C for 1 hr. The mixture was then centrifuged at 3000 rpm for 5 min. The supernatant was dialyzed against PBS at 4°C overnight. The precipitates were redissolved in 2 ml of PBS containing 0.15% bovine serum albumin and 0.15 M sodium citrate and dialyzed against PBS overnight at 4°C. Both samples were then assayed for antigen and activity of human factor IX.

Immunostaining Analysis. Cells were seeded at 5×10^4 per well on LabTek slides (VWR) and incubated at 37°C overnight. Cells were then fixed with 10% paraformaldehyde in PBS (pH 7.4) at room temperature for 10 min, followed by permeabilization by treating with cold acetone (–20°C) for 30 sec. The wells were rinsed with 10 mM sodium phosphate (pH 7.4) containing 0.15 M NaCl (PBS). The cells were then stained for human factor IX with the mouse monoclonal anti-factor IX antibody and Histostain-sp kit according to the manufacturer's instruction.

Protein Blot Analysis. Human factor IX secreted by transduced CECs was analyzed by protein blot analysis. Culture medium (1 ml) harvested from transduced or nontransduced cells was added with 23.7 μ g of purified polyclonal rabbit anti-human factor IX IgG and incubated at 4°C overnight under gentle mixing. Insoluble protein A was then added and incubation was continued for another 4 hr. The precipitates were collected by centrifugation, resuspended in 50 μ l of gel

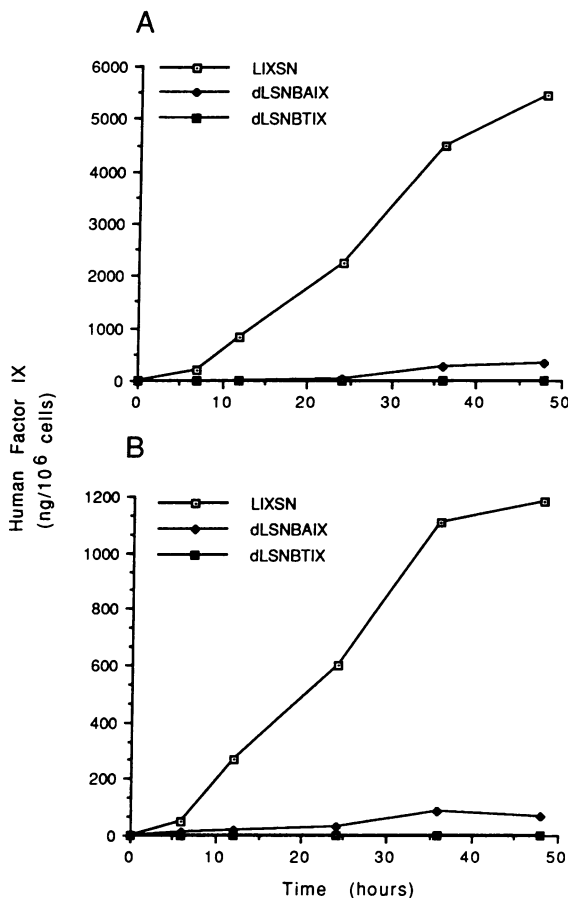

FIG. 3. Production of human factor IX by NIH 3T3 cells (A) and rat CECs (B) transduced with various recombinant retroviruses. About 2×10^6 cells were seeded in a 5-cm dish containing 4 ml of DMEM supplemented with 5% factor IX-depleted BCS. At various incubation time points, aliquots (200 ml) were removed and assayed for human factor IX by ELISA. The averages of triplicated assays are shown.

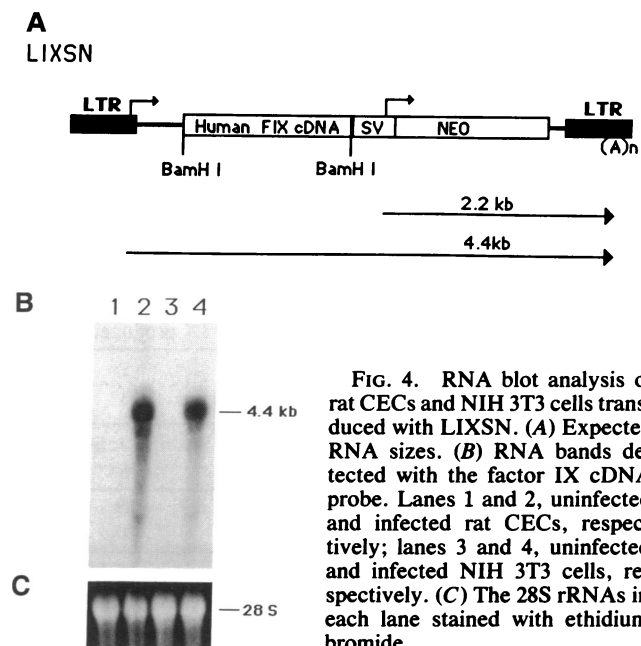

FIG. 4. RNA blot analysis of rat CECs and NIH 3T3 cells transduced with LIXSN. (A) Expected RNA sizes. (B) RNA bands detected with the factor IX cDNA probe. Lanes 1 and 2, uninfected and infected rat CECs, respectively; lanes 3 and 4, uninfected and infected NIH 3T3 cells, respectively. (C) The 28S rRNAs in each lane stained with ethidium bromide.

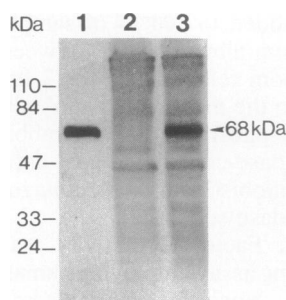

FIG. 5. Protein blot analysis of human factor IX in the culture medium produced by rat CECs transduced with LIXSN. Lane 1, purified plasma factor IX; lane 2, uninfected cells; lane 3, infected cells.

buffer (0.05 M Tris-HCl, pH 6.8/2% SDS/10% glycerol/5% 2-mercaptoethanol/0.01 mg of bromophenol blue per ml), and heated for 10 min at 85°C. The sample was centrifuged, aliquots (10 μ l) of the supernatant were subjected to electrophoresis on a 10% polyacrylamide gel containing 0.1% SDS, and the separated protein bands were electroblotted onto an Immobilon-p membrane (Millipore). Human factor IX on the membrane was detected by employing a mouse monoclonal antibody (HFIX α 40), horseradish peroxidase-conjugated goat anti-mouse IgG, and diaminobenzidine substrate.

DNA Blot Analysis. Genomic DNAs were isolated from transduced and untransduced cells as described (24). Aliquots of the DNAs (10 μ g) were digested with *Kpn* I and subjected to electrophoresis on an 0.8% agarose gel followed by blotting onto nitrocellulose membranes. The membranes were then incubated with a human factor IX cDNA fragment [1.4 kilobase pairs (kbp)] labeled with [³²P]dCTP by an oligo-labeling kit according to the manufacturer's instruction (Pharmacia).

RNA Blot Analysis. Total RNA was prepared from cultured cells, and aliquots (20 μ g per lane) were subjected to electrophoresis on a 1.2% agarose gel as described (25). The RNAs separated were then transferred to a nitrocellulose membrane and hybridized to the ³²P-labeled human factor IX cDNA.

RESULTS AND DISCUSSION

The recombinant retrovirus vectors constructed for the expression of human factor IX are shown in Fig. 1. Recombinant virus stocks of these constructs with titers of 10⁵ to 10⁶ colony-forming units (cfu)/ml were prepared and employed to infect rat CECs and NIH 3T3 cells. The titers (10⁵ to 10⁶ cfu/ml) routinely obtained for LIXSN, which has a short packaging sequence, were comparable to those of dLSN-BAIX and other similar constructs reported (7, 8) and were consistently higher than those of dLSNBTIX and dLSNR-SIX (10⁴ to 10⁵ cfu/ml) for unknown reasons. Most cells acquired the G418 resistance and survived the selection, indicating the high efficiency of gene transfer. DNA blot analyses of the cells infected with the recombinant viruses showed that all constructs employed were integrated into the host cell genomes without any noticeable rearrangements (Fig. 2). CECs and NIH 3T3 cells infected with LIXSN

retroviruses produced human factor IX at high levels, 0.84 and 3.6 μ g per 10⁶ cells per day respectively, as determined by ELISAs (Fig. 3). The other constructs with β -actin and β -tubulin promoters expressed factor IX only at marginal levels. The low expression observed for these constructs may be due to the specific designs of the constructs rather than the possibly low activity of the heterologous promoters in these cells. A construct with ribosomal protein promoter linked to factor IX cDNA in a similar design as dLSNBAIX and dLSNBTIX also expressed factor IX at a very low level; however, its analog without the neo^r gene (dLRSIX) could express factor IX at a level comparable to that of LIXSN (data not shown).

RNA blot analysis of CECs and NIH 3T3 cells transduced with LIXSN showed the single factor IX RNA transcript (about 4.4 kb) that is expected from the construct (Fig. 4). Western blot analysis of human factor IX produced by rat CECs is shown in Fig. 5. The molecular weight of factor IX in the culture medium was found to be identical to that of purified human plasma factor IX.

Human factor IX produced was analyzed by the one-stage clotting assay and ELISA employing the second-day culture medium of G418 resistant cells (Table 1). The factor IX levels in the medium, determined from the clotting activity, agreed well with those estimated by ELISA, indicating that the specific activity of the factor IX produced is virtually 100%. To further test the γ -carboxylation of the factor IX produced, the medium was then treated with barium citrate. Human factor IX precipitated again showed full activity. The factor IX recovery in the barium precipitation was about 60%. This is primarily due to the protein loss during the procedure and not to low or null γ -carboxylation of the factor IX produced, as evidenced by little factor IX antigen detected in the supernatant of the barium precipitation (Table 1). These results indicate that the required posttranslational modifications, including γ -carboxylation, are essentially complete. This is also in good agreement with the assay results of factor IX in the medium.

When the CECs transduced with the LIXSN vector were immunostained, the subcellular organelles, presumably secretory granules of the cells, were clearly stained for human factor IX, whereas the nontransduced cells showed no such staining (Fig. 6). No noticeable morphological differences were observed between the transduced and nontransduced cells. Some cells among the transduced cells stained stronger than others, indicating the variability of the expression of factor IX from cell to cell, probably due to the integration site(s) and copy numbers of the vector DNAs in the host cell genome. All of these cells, however, must be expressing the neomycin-resistance gene at a level high enough to confer the cells with the resistance to G418 added to the medium. The results agree well with the high level of synthesis and secretion of human factor IX in these cells. These results clearly demonstrate that CECs present in the principal vasculature can produce fully active factor IX with

Table 1. Analysis of human factor IX produced by transduced rat CECs and NIH 3T3 cells

Cells	Medium			Barium precipitation					
	Antigen, ng/ml	Activity, ng/ml	Specific activity, %	Precipitate			Supernatant		
				Antigen, ng/ml	Activity, ng/ml	Specific activity, %	Antigen, ng/ml	Activity, ng/ml	
CEC	415	456	109	250	262	105	1	4.6	
NIH 3T3	396	385	97	227	222	97	6.5	2.4	

The amount of human factor IX was quantitated by ELISA (Antigen columns) and by clotting assay (Activity columns). The specific activity is expressed as a percentage of the amount of factor IX determined from clotting activity over that of factor IX determined by ELISA. The conditions used are similar to those for Fig. 3, except that about 2 \times 10⁶ cells were plated in 5 ml of medium for each experiment, and the culture media were harvested for assays after 2.5 days.

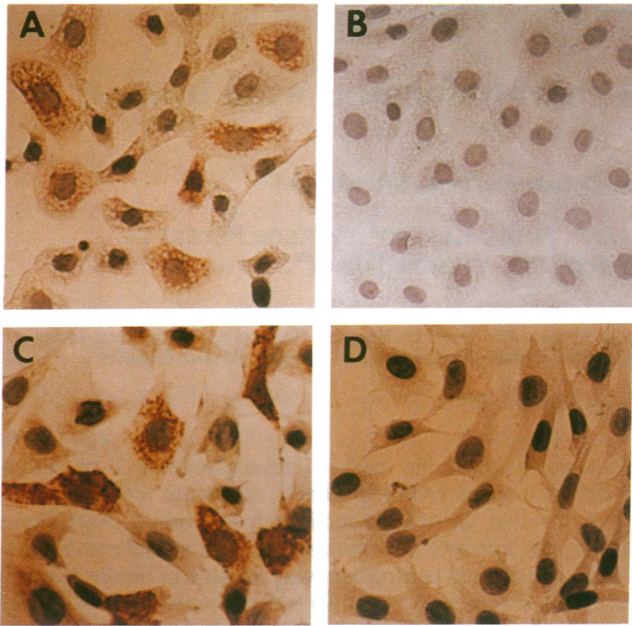

FIG. 6. *In situ* immunostaining of rat CECs and NIH 3T3 cells with the monoclonal antibody specific to human factor IX. (A and B) Rat CECs transduced and nontransduced with LIXSN. (C and D) NIH 3T3 cells transduced and nontransduced with LIXSN. Cells were counterstained with hematoxylin after immunostaining (see text). ($\times 256$.)

transfer into CECs at vascular sites in the animal models is necessary.

We thank Dr. W. R. Church for providing us with the monoclonal antibody, Dr. Gary J. Nabel for his valuable discussions and help, and Ming Liu for his technical help. This work is supported in part by National Institutes of Health Grants PO1-DK42718 and HL38644 and by a research grant from the Hemophilia Foundation of Michigan to K.K.

1. Luban, N., Bray, G., Hoyer, L. & Toy, P. (1989) in *Hematology, Educational Program of the American Society of Hematology* (Saunders, Philadelphia), pp. 68–73.
2. Roberts, H., Ginsberg, D. & Gitscher, J. (1989) in *Hematology, Educational Program of the American Society of Hematology* (Saunders, Philadelphia), pp. 55–60.
3. Kurachi, K. (1991) in *Biotechnology of Blood*, ed. Goldstein, J. (Science Tech Publ., Madison, WI), pp. 177–195.
4. Friedmann, T. (1989) *Science* **244**, 1275–1281.
5. Miller, A. D. (1990) *Blood* **76**, 271–278.
6. Anson, D. S., Hock, R. A., Austin, D., Smith, K. J., Brownlee, G. G., Verma, I. M. & Miller, A. D. (1987) *Mol. Biol. Med.* **4**, 11–20.
7. St. Louis, D. & Verma, I. M. (1988) *Proc. Natl. Acad. Sci. USA* **85**, 3150–3154.
8. Palmer, T. D., Thompson, A. R. & Miller, A. D. (1989) *Blood* **73**, 438–445.
9. Axelrod, J. H., Read, M. S., Brinkhous, K. M. & Verma, I. M. (1990) *Proc. Natl. Acad. Sci. USA* **87**, 5173–5177.
10. Armentano, D., Thompson, A., Darlington, G. & Woo, S. L. C. (1990) *Proc. Natl. Acad. Sci. USA* **87**, 6141–6145.
11. Machovich, R. (1988) in *Blood Vessel Wall and Thrombosis*, ed. Machovich, R. (CRC, Boca Raton, FL), Vol. 1, pp. 115–140.
12. Nabel, E. G., Plautz, G. & Nabel, G. J. (1990) *Science* **249**, 1285–1288.
13. Dichek, D. A., Nussbaum, O., Degen, S. J. F. & Anderson, W. F. (1991) *Blood* **77**, 533–541.
14. Hachiya, H. L., Takayama, S., White, M. F. & King, G. L. (1987) *J. Biol. Chem.* **262**, 6417–6424.
15. Wilson, J. M., Ping, A. J., Krauss, J. C., Mayo-Bond, L., Rogers, C. E., Anderson, D. C. & Todd, R. F., III (1990) *Science* **248**, 1413–1416.
16. Yu, S. F., Ruden, T. V., Kantoff, P. W., Garber, C., Seiberg, M., Ruther, U., Anderson, W. F., Wagner, E. F. & Gilboa, E. (1986) *Proc. Natl. Acad. Sci. USA* **83**, 3194–3198.
17. Busby, S., Kumar, A., Joseph, M., Halfpap, L., Insley, M., Berkner, K., Kurachi, K. & Woodbury, R. (1985) *Nature (London)* **316**, 271–273.
18. Wilson, J. M., Johnson, D. E., Jefferson, D. M. & Mulligan, R. C. (1988) *Proc. Natl. Acad. Sci. USA* **85**, 4421–4425.
19. Danos, O. & Mulligan, R. C. (1988) *Proc. Natl. Acad. Sci. USA* **85**, 6460–6464.
20. Hirosawa, S., Fahner, J. B., Salier, J.-P., Wu, C.-T., Lovrien, E. W. & Kurachi, K. (1990) *Proc. Natl. Acad. Sci. USA* **87**, 4421–4425.
21. Mann, R., Mulligan, R. C. & Baltimore, D. (1983) *Cell* **33**, 153–159.
22. Miller, A. D. & Buttimore, C. (1986) *Mol. Cell. Biol.* **6**, 2895–2902.
23. McKee, P. A. (1983) in *The Metabolic Basis of Inherited Diseases*, eds. Sanbury, J. B., Wyngaarden, J. B., Fredrickson, D. S., Goldstein, J. L. & Brown, M. S. (McGraw-Hill, New York), 5th Ed., pp. 1531–1560.
24. Kusumoto, H., Hirosawa, S., Salier, J. P., Hagen, F. S. & Kurachi, K. (1988) *Proc. Natl. Acad. Sci. USA* **85**, 7307–7311.
25. Yao, S.-N., DeSilva, A. H., Kurachi, S., Samuelson, L. C. & Kurachi, K. (1991) *Thromb. Haemost.* **65**, 52–58.

various biological properties virtually identical to those of plasma factor IX.

ECs play an essential role(s) in controlling multiple functions of other cells, modulating the consistency of the circulating blood, and in blood vessel function (11). ECs are also known to bind a number of blood proteins, including factor IX, and specific receptors on the cell surface modulate the functions of those proteins. Factor IX bound to ECs shows about 3-fold higher efficiency of activation than unbound factor IX molecules. This suggests that the production of factor IX by CECs may not cause any significant deleterious effects on CECs themselves *in vivo* as long as the expression level is well controlled. This is consistent with the absence of any noticeable morphological changes observed for the CECs expressing a significant level of factor IX in the present study. The results obtained in this study clearly show that CECs satisfy the most fundamental conditions required for a somatic cell gene therapy approach for hemophilia B. Furthermore, the direct contact of vascular endothelium with the bloodstream, which ensures an efficient transportation of the recombinant factor IX produced, is an important feature in considering CECs for producing factor IX, because one of the problems encountered in the approach with the extensively studied skin fibroblast cells is their apparently poor efficiency to transport recombinant factor IX into the circulation (8). In addition, since any somatic gene therapy may be required multiple times during the lifetime of the patient, relatively easy access of the CECs for potential *in vivo* gene transfer approaches is also important. Optimization of the *in vivo* gene