

## Analysis of Cellular Integration Sites in Avian Sarcoma Virus-Infected Duck Embryo Cells

TONA M. GILMER AND J. THOMAS PARSONS\*

*Department of Microbiology, University of Virginia School of Medicine, Charlottesville, Virginia 22908*

Received for publication 9 July 1979

The cellular sites of integration of avian sarcoma virus (ASV) have been examined in clones of duck embryo cells infected with the Bratislava 77 strain of ASV using restriction endonuclease digestion, agarose gel electrophoresis, Southern blotting, and hybridization with labeled ASV complementary DNA probes. DNA prepared from 11 clones of duck embryo cells infected with the Bratislava 77 strain of ASV was digested with the restriction enzymes *Hpa*I, which cleaves once within the viral genome, and *Hind* III, which cleaves twice within the viral genome, and the virus-cell DNA juncture fragments were resolved by agarose gel electrophoresis. Analysis of the virus-cell junctures present in individual ASV-infected duck embryo clones revealed that all clones contain at least one copy of nondefective proviral DNA with some clones containing as many as 5 to 6 copies of proviral DNA. A comparison of the virus-cell juncture fragments present in different ASV-infected clones showed that each clone contains a unique set of virus-cell junctures. These data suggest that ASV DNA can integrate at multiple sites within the duck embryo cell genome and that these sites appear to be different as defined by digestion with the restriction enzymes *Hpa*I and *Hind*III.

The replication of the avian sarcoma-leukosis viruses requires the covalent insertion of a DNA copy of the viral genome (DNA provirus) into the DNA of the host cell (21). The mechanisms by which proviral DNA is synthesized and integrated after tumor virus infection have been the object of intense study during the past several years (1, 2, 23). The use of restriction endonucleases, DNA blotting techniques (18), and filter hybridization with labeled viral nucleic acid probes has facilitated the characterization of both integrated avian sarcoma virus (ASV) proviral DNA (4, 9, 15) and the viral DNA intermediates synthesized after infection of cells with ASV (8, 16). Using these techniques, Hsu et al. (8) and Shank et al. (16) demonstrated that linear ASV DNA, synthesized shortly after infection, is colinear with the viral RNA genome and contains a 300 base pair terminal repeat consisting of DNA sequences derived from both the 5' and 3' ends of the viral RNA genome. A similar analysis of covalently closed circular viral DNA isolated from the nuclei of infected cells (7, 17) has revealed at least two species of monomeric covalently closed circular viral DNA (8, 16). The smaller of the two species of circular viral DNA appears to contain only one copy of the terminal repeat, whereas the larger appears to contain two copies of this repeat. Which of these species is the immediate precursor of integrated proviral DNA remains to be demonstrated. Digestion of DNA purified from ASV-

transformed avian or mammalian cells with the restriction endonucleases *Pvu*I or *Eco*RI, both of which cleave within the terminally repeated viral DNA sequences, releases an identical set of *Pvu*I viral DNA fragments or *Eco*RI viral fragments (4, 9, 15; C. J. Collins et al., submitted for publication). These data demonstrate that integration of viral DNA takes place at a site within the terminally repeated sequences of the viral genome. In the experiments reported here we have examined the cellular integration sites in individual clones of duck embryo (DE) cells infected with strain Bratislava 77 of ASV (B<sub>77</sub>-ASV). We have observed that all B<sub>77</sub>-ASV-infected DE cell clones contain at least one copy of integrated proviral DNA, and some clones contain as many as 5 to 6 copies. We have used restriction endonucleases which cleave once or twice within the viral DNA genome (*Hpa*I or *Hind*III) to identify fragments containing covalently joined viral and cellular DNA sequences. Analysis of 11 individual B<sub>77</sub>-ASV-infected DE cell clones demonstrated that each clone contains a unique set of virus-cell DNA junctures. We conclude that ASV DNA can integrate at multiple sites within the DE cell genome and that these sites appear to be different as defined by digestion with the restriction enzymes *Hpa*I and *Hind*III.

### MATERIALS AND METHODS

**Cells and viruses.** Primary cultures of chicken

embryo (CE) cells were prepared from 10-day-old, gs-negative/chf-negative/Marek-negative embryos (Spafas, Norwich, Conn.). Primary cultures of DE cells were prepared from 13-day-old Peking duck embryos (Truslow Farms, Md.). Cultures were maintained in Dulbecco-modified Eagle medium (Flow Laboratories Inc., Rockville, Md.) supplemented with 10% tryptose phosphate (Difco Laboratories, Detroit, Mich.) and 5% calf serum (Flow Laboratories) as described previously (13, 14). B<sub>77</sub>-ASV was originally provided by R. Smith, Duke University, Durham, N.C.

Clones of B<sub>77</sub>-ASV-infected DE cells were obtained as follows. Secondary cultures of DE cells were trypsinized and seeded at a concentration of 10<sup>5</sup> cells per 60-mm dish in 4 ml of Dulbecco-modified Eagle medium supplemented with 10% tryptose phosphate and 5% fetal calf serum. After several hours, the media were removed and the cells were infected with B<sub>77</sub>-ASV at a multiplicity of 0.001 to 0.5 focus-forming unit (FFU) per cell in 2  $\mu$ g of polybrene per ml (Aldrich Chemical Co., Milwaukee, Wis.). Eighteen to 24 h later, the cells were trypsinized and plated in 60-mm dishes at a concentration of 10<sup>4</sup> cells per ml in 0.5% agar supplemented with Ham's F10 medium (Flow Laboratories), 10% tryptose phosphate, 5% fetal calf serum, and 1% vitamins (Flow Laboratories). Well isolated macroscopic colonies were aspirated 10 to 21 days after plating and placed in microtiter wells. Individual clones were grown to a total cell density of 1  $\times$  10<sup>7</sup> to 2  $\times$  10<sup>7</sup> cells.

Uncloned B<sub>77</sub>-DE cells were obtained by infecting secondary cultures of DE cells (ca. 3.5  $\times$  10<sup>6</sup> cells per 100-mm dish) with 0.1 to 0.5 FFU of B<sub>77</sub>-ASV per cell in 2  $\mu$ g of polybrene per ml. The infected cells were subcultured at 3-day intervals thereafter. The majority of cells were transformed 8 to 12 days after infection.

**Isolation of cellular DNA.** High-molecular-weight DNA from normal and B<sub>77</sub>-ASV-infected DE cells was purified as described previously (4). DNA preparations enriched for linear B<sub>77</sub>-ASV DNA were prepared from the cytoplasm of QT<sub>6</sub> cells (12), infected with B<sub>77</sub>-ASV for 18 to 20 h (7, 22). B<sub>77</sub>-ASV-infected QT<sub>6</sub> cells were washed twice with phosphate-buffered saline, scraped from the culture dishes, and suspended in NTE buffer (25 mM NaCl-50 mM Tris-hydrochloride [pH 8.5]-2 mM EDTA) at a concentration of 10<sup>7</sup> cells per ml. Cells were lysed by the addition of Nondidet P-40 to a final concentration of 0.5%, and the nuclei were removed by centrifugation at 5,000  $\times$  g for 5 min. The supernatant (cytoplasmic fraction) was digested with pronase B (500  $\mu$ g/ml) for 1 h at 37°C and extracted twice with STE (0.1 M NaCl-10 mM EDTA-20 mM Tris-hydrochloride [pH 8])-buffered phenol, and the nucleic acids were precipitated with ethanol. The precipitated nucleic acids were suspended in 20 mM Tris-hydrochloride-1 mM EDTA (pH 7.6) (TE buffer) digested with RNase A (100  $\mu$ g/ml) for 2 h at 37°C and pronase (100  $\mu$ g/ml) for 30 min at 37°C. The nucleic acids were then extracted twice with STE-phenol, and the DNA was recovered by ethanol precipitation.

**Restriction endonuclease digestion.** Restriction endonucleases *EcoRI* and *HindIII* were purchased from Bethesda Research Laboratories; *PvuI* and *HpaI* were from New England Biolabs. Digestions with *EcoRI* were carried out in 100 mM Tris-hydrochloride

(pH 7.4)-50 mM NaCl-10 mM MgCl<sub>2</sub>-100- $\mu$ g/ml gelatin; digestions with *HindIII* were in 20 mM Tris-hydrochloride (pH 7.4)-60 mM NaCl-10 mM MgCl<sub>2</sub>; digestions with *HpaI* were in 10 mM Tris-hydrochloride (pH 7.4)-20 mM NaCl-10 mM MgCl<sub>2</sub>-100- $\mu$ g/ml gelatin; and digestions with *PvuI* were in 6 mM Tris-hydrochloride (pH 7.4)-150 mM NaCl-10 mM MgCl<sub>2</sub>-100- $\mu$ g/ml gelatin. Digestion of cellular DNA was carried out at a concentration of 10 to 20  $\mu$ g/ml for 60 min at 37°C. Complete digestion of cellular DNAs was monitored by the addition of lambda DNA to each sample.

**Synthesis of cDNA.** The preparation of <sup>32</sup>P-labeled complementary DNA (cDNA) representative of virtually the entire B<sub>77</sub>-ASV genome was carried out in a 0.2-ml reaction containing the following: 40 mM Tris-hydrochloride (pH 7.6); 30 mM NaCl; 5 mM MgCl<sub>2</sub>; 0.6 mM dithiothreitol; 0.1 mM dATP, dGTP, and TTP; 0.4 to 0.6  $\mu$ M [ $\alpha$ -<sup>32</sup>P]dCTP (New England Nuclear; specific activity, 200 to 500 Ci/mmol); 10  $\mu$ g of actinomycin D, 125  $\mu$ g of calf thymus DNA fragments prepared by the method of Summers (19); and 90 to 100 U of RNA-dependent DNA polymerase. After incubation at 37°C for 90 min, the <sup>32</sup>P-labeled cDNA was purified as described previously (14).

**Agarose gel electrophoresis.** Agarose gel electrophoresis was carried out in horizontal slab gels (16.5 by 14.5 by 0.6 cm) cast with 0.75 or 0.85% agarose (Seakem) containing 40 mM Tris-5 mM sodium acetate-1 mM EDTA (pH 7.8) for 4 h at 100 V. The DNA was stained with ethidium bromide (2.5  $\mu$ g/ml) and photographed under UV light to record the position of lambda and adenovirus DNA fragments added as molecular weight markers.

**Filter hybridization.** Transfer of DNA contained in agarose gels to nitrocellulose filter paper (Schleicher & Schuell Co., Keene, N.H.) was carried out by the method of Southern (18). After heating for 3 h at 80°C (in vacuo), the filters were incubated for 4 h at 68°C in preincubation mix (5). Hybridizations were carried out in 0.9 M NaCl-0.09 M sodium citrate (pH 7.0) containing 0.5% sodium dodecyl sulfate, fragmented calf thymus DNA (100  $\mu$ g/ml), mouse liver rRNA (20  $\mu$ g/ml), and <sup>32</sup>P-labeled B<sub>77</sub>-ASV cDNA<sub>total</sub> (5 pmol/ml; specific activity, 5  $\times$  10<sup>5</sup> to 8  $\times$  10<sup>5</sup> cpm/pmol) for 24 to 48 h at 68°C. After hybridization, the nitrocellulose filters were washed with 0.15 M NaCl-0.015 M sodium citrate (pH 6.8) for 3 h at 65°C, dried, and subjected to autoradiography.

## RESULTS

**Restriction enzyme analysis of integrated and unintegrated B<sub>77</sub>-ASV DNA.** We employed four restriction endonucleases (*EcoRI*, *PvuI*, *HpaI*, and *HindIII*) to examine the sequence arrangement of integrated and unintegrated viral DNA sequences in DE cells infected with B<sub>77</sub>-ASV. Figure 1 shows the virus-specific DNA fragments obtained when these enzymes were used to digest linear cytoplasmic DNA. In the absence of endonuclease digestion, two species of linear viral DNA were observed (Fig. 1, lane E) having molecular weights of 6.4 and 5.1 Md (Md = 10<sup>6</sup> daltons), respectively.

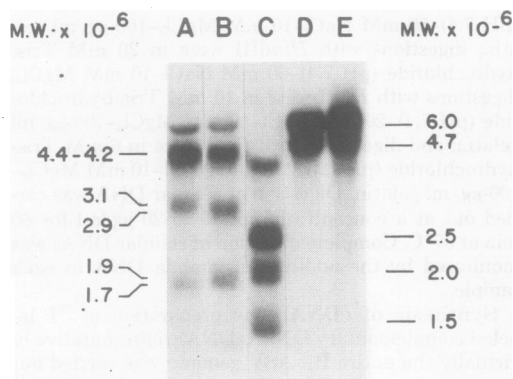

FIG. 1. Restriction endonuclease digestion of linear *B*<sub>77</sub>-ASV DNA. Cytoplasmic DNA was prepared from QT<sub>6</sub> cells infected with *B*<sub>77</sub>-ASV as described in the text. DNA preparations were digested to completion with either *Hpa*I, *Hind*III, *Eco*RI, or *Pvu*I and subjected to electrophoresis on a 0.85% agarose gel, and the DNA was transferred to nitrocellulose filters. Virus-specific DNA fragments were detected by hybridization with <sup>32</sup>P-labeled *B*<sub>77</sub>-ASV cDNA<sub>total</sub> followed by autoradiography as described in the text. Cytoplasmic DNA digested with (lane A) *Hpa*I, (lane B) *Hind*III, (lane C) *Eco*RI, or (lane D) *Pvu*I; (lane E) undigested. The molecular weight of virus-DNA fragments was determined by comparison with *Eco*RI- and *Hind*III-digested lambda DNA and *Bam*HI-digested adenovirus 2 DNA fragments electrophoresed in parallel lanes.

These viral DNA species were of the size expected for double-stranded linear viral DNA transcribed from nondefective (*nd*) and transformation-defective (*td*) *B*<sub>77</sub>-ASV RNA. The virus-specific fragments obtained after digestion of linear DNA preparations with the enzymes *Hpa*I (lane A), *Hind*III (lane B), *Eco*RI (lane C), and *Pvu*I (lane D) are also shown in Fig. 1. The restriction sites within the *B*<sub>77</sub>-ASV genome for each of these enzymes have been determined by carrying out a series of secondary digestions with other restriction enzymes and/or preparative isolation of individual restriction fragments and subsequent redigestion with another enzyme (Fig. 2). Linear DNA preparations contain both *nd* and *td* viral DNAs (Fig. 1, lane E). Cleavage of these preparations with *Hpa*I or *Hind*III yielded two large viral fragments from the 3' end of the viral genome and a common fragment from the 5' end. *Hpa*I digestion (Fig. 1, lane A) generated a 4.4-Md fragment which is derived from *nd* viral DNA [Fig. 2(c)] and a 3.1-Md fragment which is derived from *td* viral DNA [Fig. 2(d)]. The left-hand end (5') of both genomes is contained within the 1.7-Md *Hpa*I fragment. Similarly, *Hind*III cleavage (Fig. 1, lane B) of *nd* and *td* viral DNA generated a 4.2-

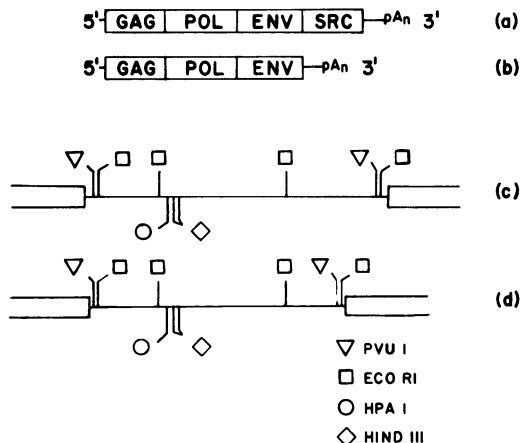

FIG. 2. Restriction endonuclease map of *B*<sub>77</sub>-ASV proviral DNA. The structure of *nd* *B*<sub>77</sub>-ASV RNA and *td* *B*<sub>77</sub>-ASV RNA is shown in (a) and (b). The restriction endonuclease map of *nd* *B*<sub>77</sub>-ASV proviral DNA and *td* *B*<sub>77</sub>-ASV proviral DNA is shown in (c) and (d). The sites of enzyme cleavage are discussed in the text. In (c) and (d), □ designates host cell DNA; —, designates *B*<sub>77</sub> proviral DNA.

Md fragment and a 2.9-Md fragment, respectively. The 1.9-Md *Hind*III fragment includes the 5' end of both *nd* and *td* genomes. *Eco*RI digestion of *nd* linear viral DNA produced three *Eco*RI fragments (Fig. 1, lane C) (2.5, 2.0, and 1.5 Md), whereas the *td* *B*<sub>77</sub>-ASV DNA produced fragments of 2.5, 1.5, and 0.6 Md (the 0.6-Md fragment has been electrophoresed off the gel in Fig. 1; however, see Fig. 4). Cleavage of linear *B*<sub>77</sub>-ASV DNA with *Pvu*I yielded two viral DNA fragments, a 6.0-Md fragment from *nd* DNA and a 4.7-Md fragment from *td* DNA (Fig. 1, lane D). The endonuclease cleavage sites shown in Fig. 2 are essentially identical to the sites obtained by Shank et al. (16), Hsu et al. (8), and Taylor et al. (20).

In the experiments presented below, we used the restriction enzymes *Eco*RI and *Pvu*I, both of which cleave within the terminally repeated sequence of *B*<sub>77</sub>-ASV DNA (Fig. 2) to quantitate the relative amounts of integrated *nd* and *td* *B*<sub>77</sub>-ASV proviral genomes. In addition, we have used the restriction enzymes *Hpa*I and *Hind*III to analyze the viral DNA fragments covalently linked to cellular DNA sequences (virus-cell juncture fragments; Fig. 2).

**Analysis of viral DNA sequences in clones of *B*<sub>77</sub>-ASV-infected DE cells: digestion with *Pvu*I and *Eco*RI.** To examine the sites in viral and cellular DNA involved in integration of *B*<sub>77</sub>-ASV proviral DNA in DE cells, we isolated cellular DNA from cloned and un-

cloned populations of DE cells infected with B<sub>77</sub>-ASV. DNA was purified from each of 11 clones and digested with *Pvu*I and *Eco*RI (Fig. 3 and 4). All of the clones, as well as uncloned B<sub>77</sub>-ASV-infected DE cells, contained a viral *Pvu*I fragment of 6.0 Md, corresponding to *nd* B<sub>77</sub>-ASV DNA (Fig. 3). Five of the 11 clones and uncloned infected cells contained a 4.7-Md *Pvu*I viral DNA fragment, corresponding to the *td* B<sub>77</sub>-ASV DNA (Fig. 3). Densitometry of the autoradiograms indicated that the relative molar amounts of *nd* and *td* proviral DNA varied from 2:1 (clone 3) to 1:4 (clone 6). *Pvu*I digestion of clone 4 DNA yielded a viral *Pvu*I fragment of 3.8 Md in addition to the 4.7-Md and 6.0-Md *Pvu*I fragments noted above. A similar analysis

of clone 9 DNA revealed viral *Pvu*I fragments of 6.0 Md, 5.0 Md, and 3.8 Md. The latter two viral fragments appear to contain one or more deletions of viral DNA sequences; however, the exact boundaries of these deletions are not known.

Digestion of DNA from the individual B<sub>77</sub>-ASV-infected DE clones with *Eco*RI and analysis of the virus-specific DNA fragments (Fig. 4) confirmed the presence of *nd* and *td* genomes within these cells. All of the clones contained a 3' terminal, 2.0-Md *Eco*RI fragment which includes the *src* gene sequences (4, 8, 16). In addition, the clones in which a 4.7-Md *Pvu*I fragment was observed also exhibited a 0.6-Md *Eco*RI fragment which is derived from the 3' end of the *td* ASV genome (Fig. 2). The dele-

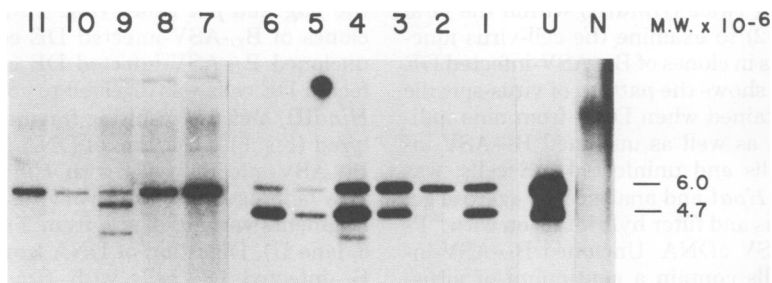

FIG. 3. *Pvu*I digestion of DNA prepared from B<sub>77</sub>-ASV-infected DE cell clones and uncloned B<sub>77</sub>-ASV-infected DE cells. Cellular DNA prepared from 11 B<sub>77</sub>-ASV-infected DE cell clones (lanes 1 to 11), uncloned B<sub>77</sub>-ASV-infected DE cells (lane U), and uninfected DE cells (lane N) was digested to completion with *Pvu*I, subjected to electrophoresis on an 0.75% agarose gel, and blotted, and the viral DNA fragments located by hybridization with <sup>32</sup>P-labeled B<sub>77</sub>-ASV cDNA were followed by autoradiography as described in the text. The molecular weights of the *Pvu*I viral DNA fragments were determined as in Fig. 1.

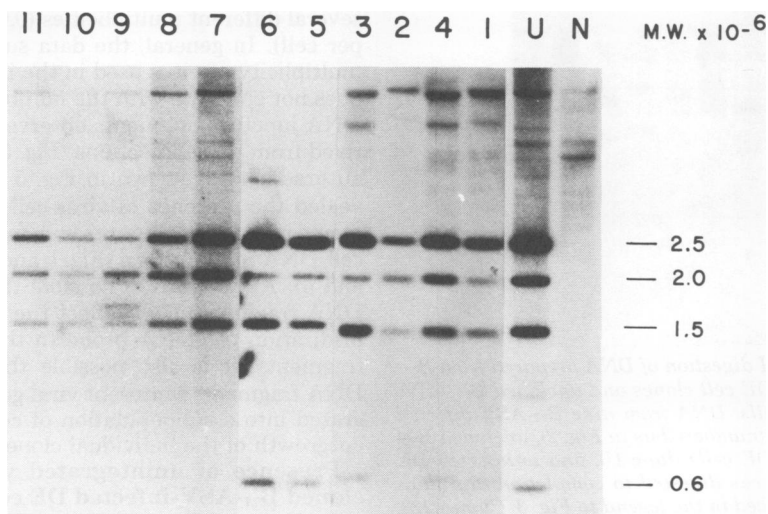

FIG. 4. *Eco*RI digestion of DNA prepared from B<sub>77</sub>-ASV-infected DE cell clones and uncloned B<sub>77</sub>-ASV-infected DE cells. Cellular DNA prepared from 11 clones of B<sub>77</sub>-ASV-infected DE clones (lanes 1 to 11), uncloned B<sub>77</sub>-ASV-infected DE cells (lane U), and uninfected DE cells (lane N) was digested to completion with *Eco*RI and analyzed as described in the legend to Fig. 3.

tion(s) of viral DNA sequences shown by the *PvuI* analysis of clone 9 DNA was also apparent in the *EcoRI* digestion pattern exhibited by this DNA (Fig. 4, lane 9). The small amount of DNA obtained from clones 4 and 9 has precluded a detailed mapping of these deletions. The results of the *PvuI* and *EcoRI* digestion experiments confirm the previous reports (4, 9, 15) which show that integration of viral DNA involves recombination with host DNA at restricted sites in the viral genome. These sites appear to reside within the terminally repeated sequences as defined by *PvuI* and *EcoRI* digestion.

**Analysis of integrated viral DNA sequence in cloned B<sub>77</sub>-ASV-infected DE cells: digestion with *HpaI* and *HindIII*.** We used restriction endonucleases which cleave once (*HpaI*) or twice (*HindIII*) within the viral genome (Fig. 2) to examine the cell-virus junction fragments in clones of B<sub>77</sub>-ASV-infected DE cells. Figure 5 shows the pattern of virus-specific fragments obtained when DNA from nine individual clones, as well as uncloned B<sub>77</sub>-ASV-infected DE cells and uninfected DE cells, was digested with *HpaI* and analyzed by agarose gel electrophoresis and filter hybridization with <sup>32</sup>P-labeled B<sub>77</sub>-ASV cDNA. Uncloned B<sub>77</sub>-ASV-infected DE cells contain a continuum of virus-specific DNA fragments having molecular weights of 3.5 to 10 Md (Fig. 5, lane U). In contrast, DNA from all of the B<sub>77</sub>-ASV DE cell

clones cleaved with *HpaI* exhibits a unique and characteristic pattern of virus-cell DNA junction fragments, ranging from the relatively simple patterns of clones 2, 8, and 9, to the more complex patterns of clones 1, 3, and 4. None of the clones contained significantly large amounts of *HpaI* DNA fragments migrating at the position of unintegrated *HpaI* DNA (4.4, 3.1, and 1.7 Md, respectively; Fig. 1) or full-length linear viral DNA (6.0 Md). Therefore, the *HpaI* virus-cell DNA junctions observed in Fig. 5 appear to be derived from integrated viral DNA sequences which have been inserted at multiple sites in the DE cell DNA.

We carried out a similar analysis using the restriction endonuclease *HindIII*, which cleaves at two closely spaced sites near the boundary of the *gag* and *pol* genes (Fig. 2). DNA from 11 clones of B<sub>77</sub>-ASV-infected DE cells as well as uncloned B<sub>77</sub>-ASV-infected DE cells and uninfected DE cells was digested to completion with *HindIII*, and the resulting fragments were analyzed (Fig. 6). Digestion of DNA from uncloned B<sub>77</sub>-ASV-infected cells with *HindIII* yielded a very heterogeneous pattern of virus-specific DNA fragments varying in size from 2 to 10 Md (Fig. 6, lane U). Digestion of DNA from 11 clones of B<sub>77</sub>-infected DE cells with *HindIII* again revealed patterns of virus-cell DNA junction fragments that are relatively simple (clones 2, 8, 9, 10, and 11) and patterns of virus-cell DNA junction fragments that are more complex (clones 1, 3, 5, and 6).

The B<sub>77</sub>-ASV-infected DE clones characterized in Fig. 5 and 6 were obtained by infection at several different multiplicities (0.001 to 0.5 FFU per cell). In general, the data suggest that the multiplicity of virus used in the initial infection does not correlate with the number of virus-cell DNA junction fragments observed in clones derived from those infections (Fig. 5, legend). The autoradiograms shown in Fig. 5 and 6 also revealed the presence of virus-cell junction fragments in reduced amounts in many of the cloned cell DNA preparations (Fig. 5 and 6, clones 1, 3, and 6). Although it is possible that these viral DNA fragments may reflect the inefficient hybridization of cDNA probe to these particular fragments, it is also possible that these viral DNA fragments represent viral genomes reintegrated into a subpopulation of cells during the outgrowth of the individual clones.

**Presence of unintegrated viral DNA in cloned B<sub>77</sub>-ASV-infected DE cells.** To determine if cloned B<sub>77</sub>-ASV DE cells contained unintegrated viral DNA species, DNA preparations were subjected to electrophoresis on agarose gels without restriction endonuclease digestion (Fig.

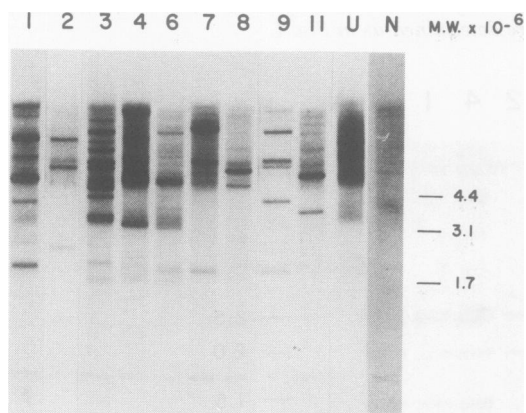

FIG. 5. *HpaI* digestion of DNA prepared from B<sub>77</sub>-ASV-infected DE cell clones and uncloned B<sub>77</sub>-ASV-infected DE cells. DNA from nine B<sub>77</sub>-ASV-infected DE cell clones (numbered as in Fig. 2), uncloned B<sub>77</sub>-ASV-infected DE cells (lane U), and uninfected DE cells (lane N) was digested to completion and analyzed as described in the legend to Fig. 3. Clones 2, 3, and 6 were infected with approximately 0.5 FFU per cell; clones 1 and 11 were infected with 0.1 FFU per cell; clones 4, 7, 8 were infected with 0.01 FFU per cell; clone 9 was infected with 0.001 FFU per cell.

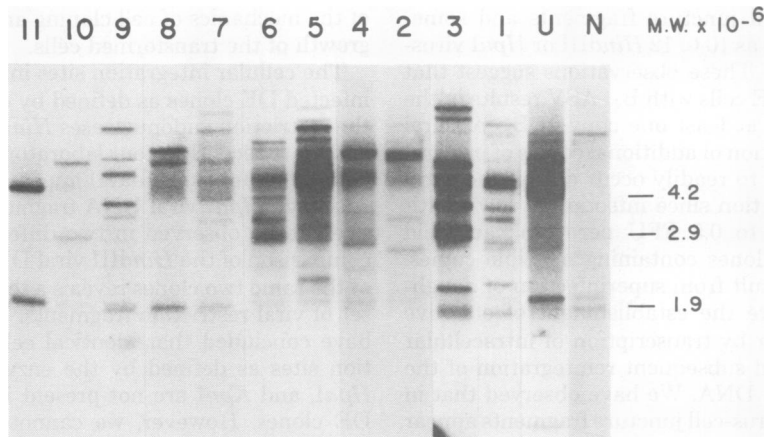

FIG. 6. *Hind*III digestion of DNA prepared from *B*<sub>77</sub>-ASV-infected DE cell clones and uncloned *B*<sub>77</sub>-ASV-infected DE cells. DNA from 11 *B*<sub>77</sub>-ASV infected DE cell clones (numbered as in Fig. 3, lanes 1 to 11), uncloned *B*<sub>77</sub>-ASV-infected DE cells (lane U), and uninfected DE cells (lane N) was digested to completion and analyzed as described in the legend to Fig. 3. The clones were infected as described in the legend to Fig. 5, except clones 10 and 5 which were infected with approximately 0.1 FFU per cell and 0.01 FFU per cell, respectively.

7). Viral DNA which comigrates with linear cytoplasmic viral DNA (Fig. 6, lane S, arrows) was observed in DNA preparations from uncloned *B*<sub>77</sub>-ASV-infected DE cells as well as DNA from clones 1, 3, 4, and 6. The major unintegrated viral DNA species observed in all of these clones appeared to be *td* linear DNA, although these same clones contained both integrated *nd* and *td* proviral DNA.

DISCUSSION

In this paper we have used restriction endonucleases to examine the topography of integrated ASV proviral DNA in cloned and uncloned *B*<sub>77</sub>-ASV-infected DE cells. Using the restriction enzymes *Eco*RI and *Pvu*I, both of which cleave within terminally repeated sequences of viral DNA, we observed identical patterns of *Eco*RI or *Pvu*I viral DNA fragments in all preparations of DNA from individual *B*<sub>77</sub>-ASV-infected DE clones. These observations support the earlier conclusions (4, 9, 15) that the terminally repeated sequences contain the major integration site on the viral genome. All transformed DE clones contained *nd* proviral DNA. In addition, 5 of 11 transformed clones contained *td* proviral DNA. In two clones, we observed proviral DNA containing internal deletions of 1.0 Md (clone 9) and 2.2 Md (clones 4 and 9). Although these deletions have not been mapped within the proviral DNA, a number of examples of deletions occurring in viral sequences other than the *src* gene were recently described (6, 10, 11).

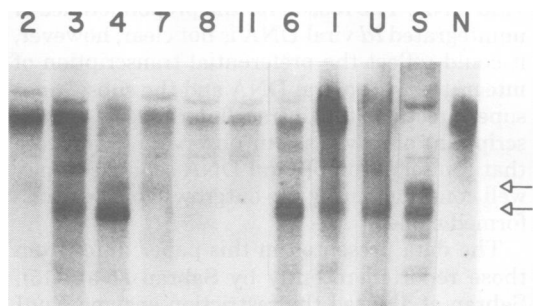

FIG. 7. Unintegrated viral DNA in *B*<sub>77</sub>-ASV-infected DE cell clones and uncloned *B*<sub>77</sub>-ASV-infected DE cells. DNA from eight *B*<sub>77</sub>-ASV-infected DE cell clones (numbered as in Fig. 3), uncloned *B*<sub>77</sub>-ASV-infected DE cells (lane U), and uninfected DE cells (lane N) was subjected to electrophoresis on 0.75% agarose gels, and virus-specific DNA was located by blotting and filter hybridization as described in the legend to Fig. 3. DNA from the cytoplasm of *B*<sub>77</sub>-ASV-infected QT<sub>8</sub> cells was prepared as described in the text and electrophoresed in lane S. The arrows indicate the position of *nd* *B*<sub>77</sub>-ASV DNA (6.4 Md) and *td* *B*<sub>77</sub>-ASV DNA (5.1 Md).

We have used the restriction enzymes *Hpa*I and *Hind*III to examine the cellular site of integration in cloned and uncloned *B*<sub>77</sub>-ASV-infected DE cells. Our analysis has revealed that all transformed DE cell clones without exception (the 11 clones presented here and 10 Prague A-infected quail cell clones [T. M. Gilmer, unpublished data]) contain at least two *Hind*III or

*HpaI* virus-cell juncture fragments and sometimes as many as 10 to 12 *HindIII* or *HpaI* virus-cell junctures. These observations suggest that infection of DE cells with B<sub>77</sub>-ASV results in the integration of at least one copy of B<sub>77</sub>-proviral DNA. Integration of additional copies of proviral DNA appears to readily occur during the early stages of infection since infection at low multiplicity (0.001 to 0.5 FFU per cell) can yield transformed clones containing multiple copies. This could result from superinfection of daughter cells before the establishment of effective interference or by transcription of intracellular viral RNA and subsequent reintegration of the resultant viral DNA. We have observed that in some clones virus-cell juncture fragments appear to be present in lower amounts, based on the intensity of the viral DNA fragments in autoradiographs. In addition, some clones contain small amounts of unintegrated linear viral DNA. This viral DNA appears to be predominantly *td* viral DNA, although the transformed clones analyzed contain both integrated *nd* and *td* proviral DNA. The reason for the preponderance of unintegrated *td* viral DNA is not clear; however, it could reflect the preferential transcription of integrated *td* proviral DNA and the subsequent superinfection (or intracellular reverse transcription) of *td* virus. Our observations indicate that reintegration of viral DNA sequences may well continue during the outgrowth of the transformed clone.

The data presented in this paper differ from those reported recently by Sabran et al. (15). Sabran et al. used the restriction enzyme *KpnI* to examine the virus-cell juncture fragments in infected chicken, duck, and quail cell clones. Although they could identify virus-cell junctures in ASV-infected quail cell clones, they could not identify such juncture fragments in ASV-infected chicken or duck cell clones. These observations led Sabran et al. to suggest that avian sarcoma viruses may be analogous to bacterial transposable elements (3) in that they can be excised and reintegrated during the growth of the infected cell. The data presented in this report support the concept that integration of avian tumor virus genome is more stable in that we readily observe virus-cell DNA junctures in clones of infected DE cells. During the past 3 years we have examined the pattern of integrated proviral DNA in several ASV-transformed mammalian cell lines and subclones derived from these cell lines and have found no indication of viral genome rearrangement (C. J. Collins and J. T. Parsons, manuscript in preparation). The inability of Sabran et al. to identify virus-cell junctures in DE cells may be the result

of the mechanics of cell cloning and subsequent growth of the transformed cells.

The cellular integration sites in various ASV-infected DE clones as defined by digestion with the restriction endonucleases *HindIII* and *HpaI* and more recently in our laboratory by *KpnI* (T. Gilmer, unpublished data) appear to be unique. Although *HpaI* viral DNA fragments of similar size can be observed in two different clones, a comparison of the *HindIII* viral DNA fragments of the same two clones reveals a totally different set of viral restriction fragments. Therefore, we have concluded that identical cellular integration sites as defined by the enzymes *HindIII*, *HpaI*, and *KpnI* are not present in the various DE clones. However, we cannot rule out the possibility that the nucleotide sequences immediately adjacent to the terminus of the proviral DNA may be identical in each of the clones and that the sequences thereafter rapidly diverge. The answer to this question will only be gained by direct sequence analysis of integrated virus-cell junctures.

#### ACKNOWLEDGMENTS

We thank Anita Fenton, Betty Creasy, and Jann Morrow for their continued technical assistance and B. Devlin, P. Highfield, and C. Collins for their helpful discussions.

This research was supported by a grant from the American Cancer Society (VC-186A) and by Public Health Service contract NO1-CP-7-1056 from the Division of Cancer Cause and Prevention, National Cancer Institute. T. G. was supported by Public Health Service grant 5T 32 CA 09109 from the National Cancer Institute.

#### LITERATURE CITED

1. Bishop, J. M. 1978. Retroviruses. *Annu. Rev. Biochem.* 47:35-88.
2. Bishop, J. M., and H. E. Varmus. 1975. The molecular biology of RNA tumor viruses, p. 3-48. *In* F. F. Becker (ed.), *Cancer, a comprehensive treatise. 2. Etiology: viral carcinogenesis*. Plenum Press, New York.
3. Bukhari, A. I., J. A. Shapiro, and S. L. Adhya (ed.). 1977. *DNA insertion elements, plasmids, and episomes*. Cold Spring Harbor Laboratory, Cold Spring Harbor, N.Y.
4. Collins, C. J., and J. T. Parsons. 1977. Integration of avian sarcoma virus DNA sequences in transformed mammalian cells. *Proc. Natl. Acad. Sci. U.S.A.* 74:4301-4305.
5. Denhardt, D. T. 1966. A membrane-filter technique for the detection of complementary DNA. *Biochem. Biophys. Res. Commun.* 23:641-646.
6. Dierks, P. M., P. E. Highfield, and J. T. Parsons. 1979. Deletion mutant of the Bratislava-77 strain of Rous sarcoma virus containing a fusion of the group-specific antigen and envelope genes. *J. Virol.* 32:567-582.
7. Guntaka, R. V., O. C. Richards, P. R. Shank, S. S. Kung, N. Davidson, E. Fritsch, J. M. Bishop, and H. E. Varmus. 1976. Covalently closed circular DNA of avian sarcoma virus: purification from nuclei of infected quail tumor cells and measurement by electron microscopy and gel electrophoresis. *J. Mol. Biol.* 106:337-357.
8. Hsu, T. W., J. L. Sabran, G. E. Mark, R. V. Guntaka,

- and J. M. Taylor. 1978. Analysis of unintegrated avian RNA tumor virus double-stranded DNA intermediates. *J. Virol.* **28**:810-818.
9. Hughes, S. H., P. R. Shank, D. H. Spector, H. J. Kung, J. M. Bishop, and H. E. Varmus. 1978. Proviruses of avian sarcoma virus are terminally redundant, coextensive with unintegrated linear DNA and integrated at many sites. *Cell* **15**:1397-1410.
  10. Linial, M., S. Brown, P. Neiman. 1978. A nonconditional mutant of Rous sarcoma virus containing defective polymerase. *Virology* **87**:130-141.
  11. Mason, W. S., T. W. Hsu, C. Yeater, J. L. Sabran, G. E. Mark, A. Kaji, and J. M. Taylor. 1979. Avian sarcoma virus-transformed quail clones defective in the production of focus-forming virus. *J. Virol.* **30**:132-140.
  12. Moscovici, C., M. G. Moscovici, H. Jimenez, M. M. C. Lai, M. J. Hayman, and P. Vogt. 1977. Continuous tissue culture cell lines derived from chemically induced tumors of Japanese quail. *Cell* **11**:95-103.
  13. Parsons, J. T., J. M. Coffin, R. K. Haroz, P. A. Bromley, and C. Weissmann. 1973. Quantitative determination and location of newly synthesized virus-specific ribonucleic acid in chicken cells infected with Rous sarcoma virus. *J. Virol.* **11**:761-774.
  14. Parsons, J. T., P. Lewis, and P. Dierks. 1978. Purification of virus-specific RNA from chicken cells infected with avian sarcoma virus: identification of genome-length and subgenome-length viral RNAs. *J. Virol.* **27**:227-238.
  15. Sabran, J. L., T. W. Hsu, C. Yeater, A. Kaji, W. S. Mason, and J. M. Taylor. 1979. Analysis of integrated avian RNA tumor virus DNA in transformed chicken, duck, and quail fibroblasts. *J. Virol.* **29**:170-178.
  16. Shank, P. R., S. H. Hughes, H. J. Kung, J. E. Majors, N. Quintrell, R. V. Guntaka, J. M. Bishop, and H. E. Varmus. 1978. Mapping unintegrated avian sarcoma virus DNA: termini of linear DNA bear 300 nucleotides present once or twice in two species of circular DNA. *Cell* **15**:1383-1395.
  17. Shank, P. R., and H. E. Varmus. 1978. Virus-specific DNA in the cytoplasm of avian sarcoma virus-infected cells is precursor to covalently closed circular viral DNA in the nucleus. *J. Virol.* **25**:104-114.
  18. Southern, E. M. 1975. Detection of specific sequences among DNA fragments separated by gel electrophoresis. *J. Mol. Biol.* **98**:503-517.
  19. Summers, J. 1975. Physical map of polyoma viral DNA fragments produced by cleavage with a restriction enzyme from *Haemophilus aegyptius*, endonuclease R. HaeIII. *J. Virol.* **15**:946-953.
  20. Taylor, J. M., T. W. Hsu, and M. M. C. Lai. 1978. Restriction enzyme sites on the avian RNA tumor virus genome. *J. Virol.* **26**:479-484.
  21. Temin, H. M. 1971. Mechanism of cell transformation by RNA tumor viruses. *Annu. Rev. Microbiol.* **25**:609-648.
  22. Varmus, H. E., S. Heasley, H. J. Kung, H. Oppermann, V. C. Smith, J. M. Bishop, and P. R. Shank. 1978. Kinetics of synthesis, structure, and purification of avian sarcoma virus-specific DNA made in the cytoplasm of acutely-infected cells. *J. Mol. Biol.* **120**:55-82.
  23. Vogt, P. K. 1977. The genetics of RNA tumor viruses, p. 341-430. *In* H. Fraenkel-Conrat and R. Wagner (ed.), *Comprehensive virology*. Plenum Press, New York.