

Polymyositis, invasion of non-necrotic muscle fibres, and the art of repetition

Gerald J D Hengstman, Baziel G M van Engelen

The presence of cellular inflammatory infiltrates with invasion of non-necrotic muscle fibres has become a prerequisite for the diagnosis of polymyositis, but a structured literature search shows that the research evidence is insufficiently strong for this histological feature to be used as a diagnostic criterion

Neuromuscular
Centre Nijmegen,
Department of
Neurology,
University Medical
Centre Nijmegen,
PO Box 9101, 6500
HB Nijmegen,
Netherlands
Gerald J D
Hengstman
resident in neurology
Baziel G M van
Engelen
neurologist

Correspondence to:
G J D Hengstman

BMJ 2004;329:1464-7

A dispute has erupted over the diagnostic criteria for polymyositis, a disorder characterised by progressive muscle weakness and the presence of inflammatory infiltrates in skeletal muscle tissue that could leave many myositis patients diagnostically adrift and excluded from receiving potentially effective treatment. It might also lead to the results of clinical studies performed by one specialist not being accepted by another because of disagreement over the diagnostic criteria used. The dispute focuses on the histopathological characteristics of polymyositis and whether the presence of inflammatory infiltrates invading non-necrotic muscle fibres is a prerequisite for the diagnosis.

To examine the validity of this presumed histological characteristic of polymyositis, we traced the original source of this statement by performing a structured literature search. We subsequently studied the original source in the light of present day knowledge on myositis.

The dispute

The idiopathic inflammatory myopathies are a group of heterogeneous disorders characterised by acquired progressive muscle weakness and inflammatory infiltrates in skeletal muscle tissue. The three main disorders in this group are dermatomyositis, polymyositis, and inclusion body myositis. These diseases differ strongly from each other, both clinically and pathophysiologically. Dermatomyositis seems to be a humorally mediated angiopathy resulting in myositis and a typical dermatitis.¹ Polymyositis is traditionally seen as an inflammatory myopathy mediated by cytotoxic T cells, which can occur in the context of another inflammatory connective tissue disease such as systemic sclerosis.¹ Inclusion body myositis, which is seen mainly in elderly people and is clinically characterised by slowly progressive asymmetric muscle weakness, is thought to be a degenerative myopathy with secondary inflammation.^{2, 3}

Diagnosing dermatomyositis, polymyositis, or inclusion body myositis depends on a combination of clinical characteristics, results of laboratory investigations (including levels of muscle associated enzymes, serology, electromyography, and muscle biopsy), and responses to treatment. Only rarely are all typical features of a disease present simultaneously, and the correct diagnosis may only become apparent over time. Dermatomyositis and polymyositis are, unlike inclusion body myositis, multi-specialty disorders, and patients with these diseases are treated by rheumatologists, neurologists, dermatologists, and specialists in internal medicine.

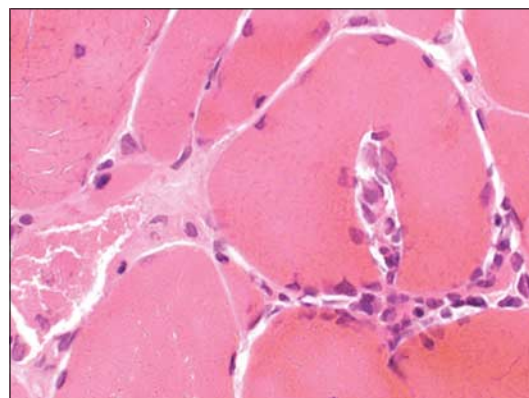

Polymyositis is histopathologically characterised by cellular inflammatory infiltrates with invasion of non-necrotic muscle fibres

The diagnoses of dermatomyositis and inclusion body myositis are straightforward, but diagnosing polymyositis is controversial. Over the past year, a dispute, primarily between rheumatologists and neurologists, has erupted over the diagnostic criteria for polymyositis. Rheumatologists tend to rely on clinical signs, symptoms, and serology, whereas neurologists rely more on histopathology in order to exclude other myopathies. This dispute was recently aired in the *Lancet* by a group of rheumatologists commenting on a review article on polymyositis and dermatomyositis.^{1, 4} Another example is an article accompanied by an editorial, and the correspondence these elicited, published in *Neurology* in which the authors stated that polymyositis hardly exists.⁵⁻⁹

While rheumatologists usually use the Bohan and Peter criteria for polymyositis,¹⁰ neurologists feel a need to confirm the diagnosis, and to exclude other myopathies, by muscle biopsy. In their view, polymyositis is histologically characterised by the presence of endomysial inflammatory infiltrates consisting of CD8 T cells invading non-necrotic muscle fibres that express major histocompatibility complex class I molecules on the sarcolemma, as shown by the criteria proposed in the recent *Lancet* review.¹

The history examined

To solve this dispute, we not only need rheumatologists and neurologists to understand each other's viewpoint, but we also need to identify the source of the dispute, preferably from a historical perspective. We therefore



References w1-w24 are on bmj.com

examined the historical background and validity of the histopathological definition of polymyositis by studying the medical literature in a structured manner.

We started with the recent *Lancet* article on dermatomyositis and polymyositis.¹ The authors write “in polymyositis, multifocal lymphocytic infiltrates surround and invade healthy muscle fibres” and provide six references to support this statement: four review articles and two book chapters (see figure).^{w1-w6}

We then studied the four reviews (the book chapters did not contain primary records or original data). All these reviews mention the presumed histological feature of polymyositis, and three of them provide references for this statement. In total 20 references are provided, including three of the initial six references.^{11-14 w1 w3 w5 w7-w17}

Examination of all journal articles resulted in our being referred to several other articles and book chapters. In total, we were referred to 205 references in order to find the original source of the statement that polymyositis is characterised by invasion of non-necrotic muscle fibres. Several of the references refer to

each other, resulting in 28 original references.^{11-14 w1-w24} Only four of these references provide original data.¹¹⁻¹⁴ The other 24 references are review articles (14), books (8), abstracts (1), or non-existent (1). It was remarkable that 19 of the 28 identified references were from just two research groups.^{12 14 w1 w3 w5-w8 w10 w12-w15 w17-w19 w22-w24}

The original sources

In the most recent of the four articles containing original data, Emslie-Smith et al studied the expression of major histocompatibility complex class I antigens, the immunolocalisation of interferon subtypes, and T cell mediated cytotoxicity in patients with dermatomyositis, polymyositis, inclusion body myositis, or Duchenne’s muscular dystrophy, and normal controls.¹⁴ The authors found invasion of non-necrotic muscle fibres by inflammatory infiltrates in all the diseases studied except dermatomyositis. They did not quantify their findings.

In the second article Ringel et al quantitatively assessed the histopathology of 57 patients with myositis.¹³ They included patients with dermatomyositis and polymyositis diagnosed according to the Bohan and Peter criteria and excluded all patients with inclusion body myositis without specifying how these patients had been identified.¹⁰ With the exception of perifascicular atrophy, no histological feature could invariably distinguish the different disorders. Invasion of non-necrotic muscle fibres was not mentioned.

The earliest article is a review article on the pathology of inflammatory muscle disorders and includes some observations made by the authors.¹¹ The authors state that they observed “mononuclear cells (indenting) the cytoplasm of non-necrotic muscle cells” in eight out of 16 polymyositis patients. They did not provide clinical data or specify the diagnostic criteria used.

In the fourth article, published in 1984, Arahata and Engel studied the histopathological features of patients with dermatomyositis, polymyositis, inclusion body myositis, scleroderma, or Duchenne’s muscular dystrophy, and normal controls.¹² They found invasion of non-necrotic muscle fibres in patients with Duchenne’s muscular dystrophy, dermatomyositis, polymyositis, and inclusion body myositis. The invasion was clearly more extensive in polymyositis and inclusion body myositis than in the other diseases, and the authors concluded that polymyositis (and inclusion body myositis) was characterised by invasion of non-necrotic muscle fibres by endomysial located inflammatory infiltrates. Crucial for the validity of this conclusion is how these patients were diagnosed, and especially how inclusion body myositis was differentiated from polymyositis.

Arahata and Engel’s patients

Although it had been described earlier, inclusion body myositis was not recognised as a distinct disease entity until the early 1980s. Until then, patients usually had been diagnosed with “treatment resistant” polymyositis. The “treatment resistance” reflects the most important clinical difference between inclusion body myositis and polymyositis: polymyositis responds to immunosuppressive and immunomodulatory treatment, whereas inclusion body myositis does not.

Histopathologically, inclusion body myositis can easily be mistaken for polymyositis because both disorders are characterised by endomysial inflammatory infiltrates with invasion of non-necrotic muscle fibres.³

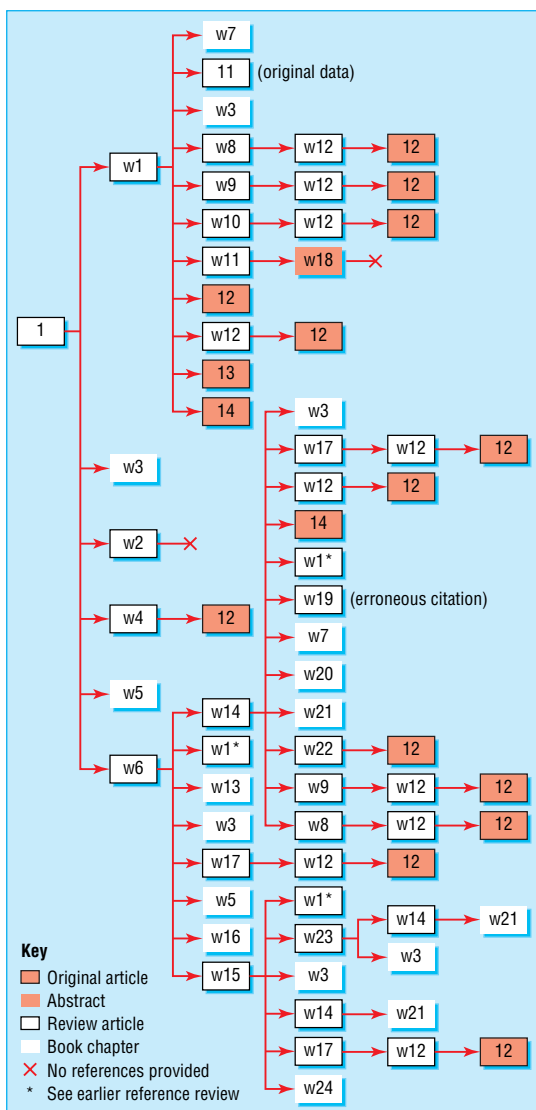

Results of reference search to find original data to support the statement “in polymyositis, multifocal lymphocytic infiltrates surround and invade healthy muscle fibres” made by Dalakas et al¹ (numbers refer to references)

The histological difference between inclusion body myositis and polymyositis consists of the presence of basophilic rimmed vacuoles, amyloid depositions, and accumulation of cytoplasmic and intranuclear tubulo-filamentous inclusions under electron microscopy in inclusion body myositis.³ However, these typical features can be absent in the initial muscle biopsies from patients with inclusion body myositis,^{3 15} and the diagnosis of inclusion body myositis (as opposed to polymyositis) in those cases relies almost entirely on the typical clinical phenotype.³

Arahata and Engel's diagnosis of myositis was "based on conventional criteria," for which the reader is referred to the Bohan and Peter criteria and a review article by Whitaker.^{10 16} Whitaker describes dermatomyositis and polymyositis, and only mentions inclusion body myositis in a classification table. Arahata and Engel state that all their patients with a diagnosis of inclusion body myositis had the typical histological findings, including vacuoles and filamentous inclusions shown by electron microscopy. All other cases, including those we would now identify as inclusion body myositis on the basis of the typical clinical phenotype (which was not fully recognised at the time the article was published) but without the vacuoles and filamentous inclusions, were diagnosed as polymyositis.³ It is thus conceivable that some of Arahata and Engel's polymyositis patients actually had early inclusion body myositis.

This is in accordance with the results of a recent study by Van der Meulen et al, which found that myositis patients who met the histological criterion of invasion of non-necrotic muscle fibres by endomysial inflammatory infiltrates all had atypical polymyositis with several clinical characteristics of inclusion body myositis.⁵

Conclusions

Several conclusions can be drawn from our review of the medical literature: some are applicable to medicine in general and some to medical literature, and some are important for doctors interested in myositis.

Firstly, an observation made in the past sometimes escapes reassessment of its validity even if recent advances in medical knowledge warrant such a reassessment. This especially seems to be the case if conclusions are cited in review articles and subsequent review articles cite only the first review article instead of the original publication. Through repetition, conclusions—even though they have become invalid over time—become embedded in the medical literature, the pathophysiological concepts of disease, and the minds of clinicians and researchers. Using review articles as references can lead to authors not familiarising themselves with the original publications. The use of review articles as references is strongly encouraged by the editorial limitations placed on the number of references that authors can provide for a manuscript. By lifting the restriction on the number of references, medical journals will probably become slightly thicker, but their quality might increase significantly.

Secondly, some authors have a strong tendency to refer to themselves. Of the 28 references we found in our literature search, 68% were from only two research groups, one of them not providing any original data. This latter group referred to their own work 29 times, all

Summary points

The recent dispute over the diagnostic criteria for polymyositis, which is potentially harmful for patients, focuses on whether polymyositis is histologically characterised by inflammatory infiltrates invading non-necrotic muscle fibres

From a historical perspective, this statement may not be valid because the polymyositis patients in the original source of this statement may actually have had inclusion body myositis and not polymyositis

Diagnostic criteria in which the presence of this histopathological feature is a prerequisite for the diagnosis of polymyositis are erroneous and are not based on solid original data

This invalid feature seems to have become embedded in the medical literature through a combination of authors' tendency to use review articles as references, authors not familiarising themselves with original publications, and authors who have a strong tendency to refer to themselves

being review articles and book chapters.^{w1 w5-w8 w13-w20 w22 w23}

Such repetition affects the opinion not only of readers but also of the authors. By repeating oneself, one can become convinced of the validity of one's own statement. Furthermore, admitting that one's conclusions are incorrect becomes practically impossible because credibility and ego are at stake. Editorial boards of medical journals should be more critical with regard to the use of references, especially because they have limited their number. References should be checked for their validity, and articles (especially review articles) should not unnecessarily refer to other review articles and book chapters but mainly to the original publications. We require detailed descriptions of the methods used for laboratory experiments, but apparently we feel no need for a detailed description of the sources of statements on pathophysiology and concepts of disease.

As for the field of myositis, invasion of non-necrotic muscle fibres by endomysial inflammatory infiltrates is a feature of inclusion body myositis and possibly of polymyositis, but in the latter disease this still needs to be confirmed. Diagnostic criteria in which the presence of this histopathological feature is a prerequisite for a diagnosis of polymyositis are erroneous and are not based on solid original data.

Myositis is a true multi-specialty disorder, and it must be recognised as such by all who deal with myositis patients. The current dispute can be turned into a positive development if we recognise that we now need to bridge the gap between dermatologists, internists, rheumatologists, and neurologists. Internationally agreed criteria, acceptable to all, need to be developed. The recent ENMC (European Neuro Muscular Centre) workshop on idiopathic inflammatory myopathies is a first step in that direction.¹⁷ Hopefully, this initiative will be followed so that we finally can agree on diagnostic criteria for these enigmatic diseases.

Sources and contributors: Both authors have extensive experience in treating patients with myositis and are active in research, both clinical and fundamental, about myositis. The Neuromuscular Centre Nijmegen has an extensive collaboration with the departments of rheumatology, dermatology, and internal medicine, and through this collaboration the authors are familiar with the different viewpoints about diagnostic criteria, treatment, etc, for myositis. The source of information used to prepare the manuscript is outlined in the manuscript itself and consists of the medical literature in general. Both authors contributed to the format of the study, the data collection and analysis, and writing the manuscript. GH is guarantor.

Funding: None.

Competing interests: None declared.

- 1 Dalakas MC, Hohlfeld R. Polymyositis and dermatomyositis. *Lancet* 2003;362:971-82.
- 2 Barohn RJ, Amato AA, Sahenk Z, Kissel JT, Mendell JR. Inclusion body myositis: explanation for poor response to immunosuppressive therapy. *Neurology* 1995;45:1302-4.
- 3 Amato AA, Gronseth GS, Jackson CE, Wolfe GI, Katz JS, Bryan WW, et al. Inclusion body myositis: clinical and pathological boundaries. *Ann Neurol* 1996;40:581-6.
- 4 Miller FW, Rider LG, Plotz PH, Isenberg DA, Oddis CV. Diagnostic criteria for polymyositis and dermatomyositis. *Lancet* 2003;362:1762-3.
- 5 Van der Meulen MFG, Bronner IM, Hoogendijk JE, Burger H, Van Venrooij WJ, Voskuyl AE, et al. Polymyositis: an overdiagnosed entity. *Neurology* 2003;61:316-21.

- 6 Amato AA, Griggs RC. Unicorns, dragons, polymyositis, and other mythological beasts. *Neurology* 2003;61:288-90.
- 7 Miller FW, Rider LG, Plotz PH, Rutkove SB, Pestronk A, Wortmann RL, et al. Polymyositis: an overdiagnosed entity. *Neurology* 2004;63:402.
- 8 Bradley WG. Polymyositis: an overdiagnosed entity. *Neurology* 2004;63:402.
- 9 Hengstman GJD, Van Engelen BGM. Polymyositis: an overdiagnosed entity. *Neurology* 2004;63:402-3.
- 10 Bohan A, Peter JB. Polymyositis and dermatomyositis (first of two parts). *N Engl J Med* 1975;292:344-7.
- 11 Carpenter S, Karpati G. The major inflammatory myopathies of unknown cause. *Pathol Annu* 1981;16:205-37.
- 12 Arahata K, Engel AG. Monoclonal antibody analysis of mononuclear cells in myopathies. I: Quantitation of subsets according to diagnosis and site of accumulation and demonstration and counts of muscle fibers invaded by T cells. *Ann Neurol* 1984;16:193-208.
- 13 Ringel SP, Carry MR, Aguilera AJ, Starcevic JM. Quantitative histopathology of the inflammatory myopathies. *Arch Neurol* 1986;43:1004-9.
- 14 Emslie-Smith AM, Arahata K, Engel AG. Major histocompatibility complex class I antigen expression, immunolocalization of interferon subtypes, and T cell-mediated cytotoxicity in myopathies. *Hum Pathol* 1989;20:224-31.
- 15 Van der Meulen MFG, Hoogendijk JE, Jansen GH, Veldman H, Wokke JH. Absence of characteristic features in two patients with inclusion body myositis. *J Neurol Neurosurg Psychiatry* 1998;64:396-8.
- 16 Whitaker JN. Inflammatory myopathy: a review of etiologic and pathogenetic factors. *Muscle Nerve* 1982;5:573-92.
- 17 Hoogendijk JE, Amato AA, Lecky BR, Choy EH, Lundberg IE, Rose MR, et al. 119th ENMC international workshop: trial design in adult idiopathic inflammatory myopathies, with the exception of inclusion body myositis, 10-12 October 2003, Naarden, The Netherlands. *Neuromuscul Disord* 2004;14:337-45.

Meeting mania 2004

David S Goldbloom

The rise in the number of meetings occurring every day in healthcare institutions shows no sign of abating. What are the factors contributing to this "meeting mania," and is there anything that can be done to counter it?

Ten years ago Abraham Bergman described the epidemic phenomenon in healthcare institutions of "meeting mania."¹ He lamented the exponential increase in the frequency of meetings and ascribed it to the proliferation of administrators and managers. He observed that meetings served several illusory purposes: communication, decision making, and responsibility. He bravely called for a moratorium on meetings for 30 days and then a gradual and filtered reintroduction with better clarity of purpose, time limits, and format. He advocated email as a useful alternative to meetings, or voicemail for communication purposes.

What has the past decade wrought? From the perspective of a former physician-in-chief of an academic health sciences centre, meeting mania has become pandemic, rivaling the 1918 influenza outbreak. Meetings, task forces, and retreats (they are never advances) pervade our agendas more than ever before. In the past 10 years several phenomena have contributed to the worsening of this problem.

Electronic wizardry

Most of us have at least the skeleton of our daily schedules captured on software that is typically uniform throughout a hospital. In order to schedule meetings, this software has the capacity to search the schedules of all potential attendees to find common times when they are free; an email follows asking you to attend, smugly knowing that you have no conflicting commitments. Orwellian concerns that your schedule of daily

activities is freely available to others notwithstanding, there is a fundamental assumption in this software that exacerbates meeting mania: if you are not "busy" as reflected by a scheduled event in your electronic calendar (typically a meeting), ergo you are not working. In fact, the opposite is probably true—the only time you may be doing productive work is when you are not in a meeting. Some colleagues have taken to blocking off time in their electronic schedules simply to render themselves impervious to the feeding frenzy of meeting schedulers.

Perhaps naively, Bergman hoped that email would serve as a better communication vehicle than face to face contact. At our hospital, it is not uncommon for senior managers to receive between 60 and 100 emails in a day. Answering email now counts as work. In the absence of a defined etiquette of electronic communication, the tyranny of distribution lists creates a barrage, at no extra cost to the sender, of information that may be only peripherally relevant to any individual recipient. Furthermore, the tragic alignment of the "reply to all" button adjacent to the "reply" button on the toolbar is a fundamental error of human engineering. It means that all too often one learns that a colleague is unable to attend a meeting to which 30 people have been invited or is simply saying, "Thanks." Who cares? Many of us succumb to the Sisyphean temptation of answering email as soon as it comes in, in the vain hope that the inbox will remain empty. It never does. More moderate souls reserve a time at the

Centre for
Addiction and
Mental Health,
250 College Street,
Toronto, ON,
Canada M5T 1R8
David S Goldbloom
senior medical
adviser, education and
public affairs
david_goldbloom@
camh.net

BMJ 2004;329:1467-9