

SYMPOSIUM REVIEW

Ca²⁺ tunnelling through the ER lumen as a mechanism for delivering Ca²⁺ entering via store-operated Ca²⁺ channels to specific target sites

Ole H Petersen¹ , Raphael Courjaret² and Khaled Machaca² 

¹MRC Group, School of Biosciences and Systems Immunity Research Institute, Cardiff University, Cardiff CF10 3AX, UK

²Department of Physiology and Biophysics, Weill Cornell Medicine Qatar, Education City, Qatar Foundation, PO Box 24144, Doha, Qatar

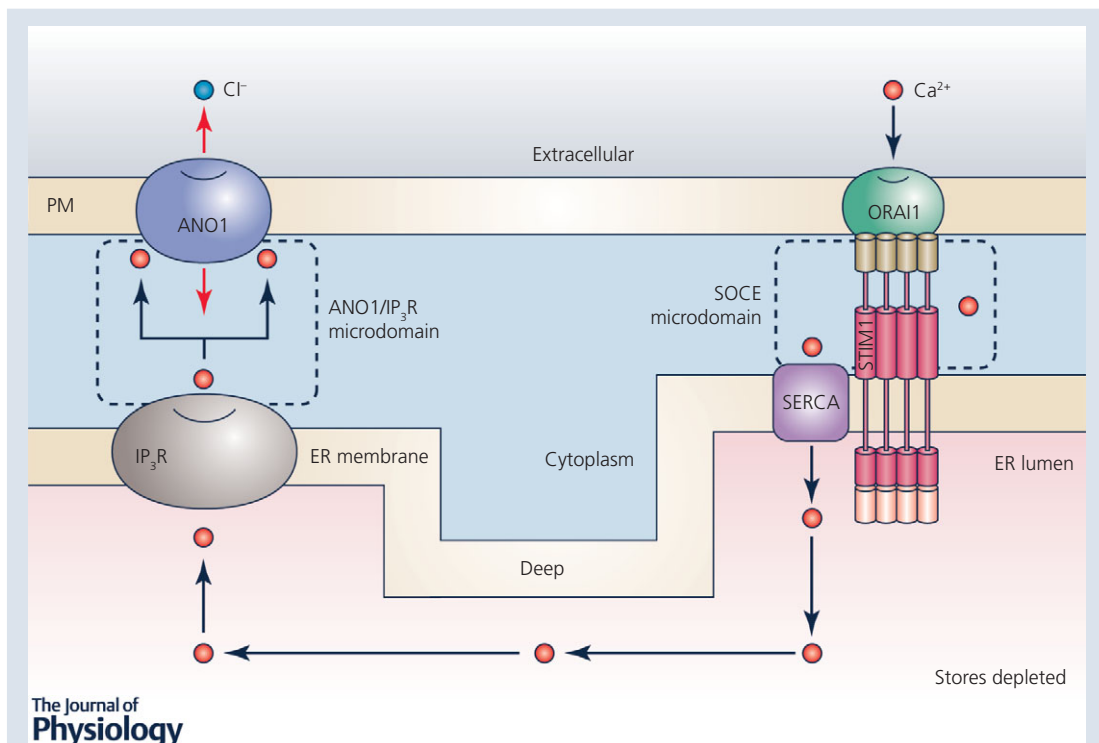

Abstract Ca²⁺ signalling is perhaps the most universal and versatile mechanism regulating a wide range of cellular processes. Because of the many different calcium-binding proteins distributed throughout cells, signalling precision requires localized rises in the cytosolic Ca²⁺ concentration. In electrically non-excitable cells, for example epithelial cells, this is achieved by primary release of

Ole Petersen CBE FRS is Medical Research Council Professor in the School of Biosciences at Cardiff University. He pioneered patch clamp single-channel and whole-cell recordings in epithelial cells and discovered messenger-mediated calcium release from the nuclear envelope as well as calcium tunnelling through the endoplasmic reticulum. More recently, he has shown how inhibition of store-operated calcium channels could be used to treat acute pancreatitis. **Khaled Machaca** is Professor of Physiology and Biophysics at Weill Cornell Medicine and the Associate Dean for Research for the Qatar campus. He is interested in calcium signalling under physiological and pathological conditions. He has comprehensively documented the remodelling of the Ca²⁺ signalling machinery during oocyte maturation and made significant contributions to the regulation of store-operated Ca²⁺ entry during the cell cycle, Orai1 trafficking and to the mechanisms governing oocyte meiotic arrest.



Ca^{2+} from the endoplasmic reticulum via Ca^{2+} release channels placed close to the physiological target. Because any rise in the cytosolic Ca^{2+} concentration activates Ca^{2+} extrusion, and in order for cells not to run out of Ca^{2+} , there is a need for compensatory Ca^{2+} uptake from the extracellular fluid. This Ca^{2+} uptake occurs through a process known as store-operated Ca^{2+} entry. Ideally Ca^{2+} entering the cell should not diffuse to the target site through the cytosol, as this would potentially activate undesirable processes. Ca^{2+} tunnelling through the lumen of the endoplasmic reticulum is a mechanism for delivering Ca^{2+} entering via store-operated Ca^{2+} channels to specific target sites, and this process has been described in considerable detail in pancreatic acinar cells and oocytes. Here we review the most important evidence and present a generalized concept.

(Received 15 November 2016; accepted after revision 5 January 2017; first published online 9 February 2017)

Corresponding authors O. H. Petersen: MRC Group, School of Biosciences and Systems Immunity Research Institute, Cardiff University, Cardiff CF10 3AX, UK. Email: PetersenOH@cardiff.ac.uk and K. Machaca: Department of Physiology and Biophysics, Weill Cornell Medicine Qatar, Education City, Qatar Foundation, PO Box 24144, Doha, Qatar. Email: khm2002@qatar-med.cornell.edu

Abstract figure legend The figure illustrates the principle by which Ca^{2+} tunnelling through the lumen of the endoplasmic reticulum (ER) can deliver Ca^{2+} entering through store-operated Ca^{2+} channels (Orai1) to a site remote from the entry site, thereby activating a specific physiological process (Ca^{2+} -sensitive Cl^- channels (ANO1)) via release through IP_3 receptors (IP_3R) placed close to the target. The primary step is Ca^{2+} release from the ER via IP_3R caused by agonist stimulation, which generates IP_3 (not shown in the figure). This causes a reduction in the Ca^{2+} concentration in the ER lumen, which triggers translocation of STIM1 molecules in the ER membrane, so that they come very close to Ca^{2+} entry channels and activate these. Ca^{2+} entering through the Orai1 channels is immediately taken up into the ER by powerful Ca^{2+} pumps (SERCA) and move with relative ease through the ER lumen by simple diffusion. The mobility of Ca^{2+} in the ER lumen is significantly higher than in the cytosol due to the much lower Ca^{2+} binding capacity.

Abbreviations ACh, acetylcholine; ANO1, anoctamin-1; CaCC, Ca^{2+} -activated Cl^- channel; CCK, cholecystokinin; CRAC channel, Ca^{2+} release-activated Ca^{2+} channel; ER, endoplasmic reticulum; IP_3 , inositol trisphosphate; IP_3R , IP_3 receptor; MCU, mitochondrial Ca^{2+} uniporter; NAADP, nicotinic acid adenine dinucleotide phosphate; NFAT, nuclear factor of activated T-cells; PIP_2 , phosphatidylinositol bisphosphate; PM, plasma membrane; PMCA, plasma membrane Ca^{2+} -activated ATPase; RyR, ryanodine receptor; SERCA, sarco/endoplasmic reticulum Ca^{2+} activated ATPase; SOAR, STIM1 Orai1-activating region; SOCE, store-operated Ca^{2+} entry; STIM, stromal interaction molecule; TMEM16A, transmembrane member 16A; TRP, transient receptor potential.

Introduction

Effective and precise intracellular Ca^{2+} signalling depends on specific Ca^{2+} sensors and transport proteins expressed differentially on organelle and plasma membranes, as well as Ca^{2+} buffers with different affinities and kinetics in different cellular compartments (Petersen *et al.* 1994; Berridge, 2016). Because Ca^{2+} can interact with many potential cellular targets, signalling precision requires localized rises of the cytosolic $[\text{Ca}^{2+}]$ ($[\text{Ca}^{2+}]_i$) (Petersen *et al.* 1994; Petersen & Verkhatsky, 2016). In the nervous system, the extremely precise control of presynaptic neurotransmitter secretion depends on close co-localization of voltage-gated Ca^{2+} channels and the exocytotic machinery (Südhof, 2013). However, the target for the action of Ca^{2+} cannot always be very close to the site of Ca^{2+} entry. A prime example of such a scenario comes from the physiology of the pancreatic acinar cells, where Ca^{2+} entry occurs at the base of the cell, whereas the control of secretion has to take place at the opposite end of the cell at the apical pole (Petersen *et al.* 1994; Petersen & Tepikin, 2008).

In these and many other electrically non-excitabile cells, which do not have voltage-gated Ca^{2+} channels and do not fire action potentials (Petersen, 1992), the primary Ca^{2+} movement is from the endoplasmic reticulum (ER) into the cytosol (Nielsen & Petersen, 1972; Berridge, 2016) and this, in turn, triggers store-operated Ca^{2+} entry (Putney, 1986; Petersen & Tepikin, 2008; Parekh, 2010). Diffusion of Ca^{2+} through the cytosol, from an entry site to a distant target, would potentially activate many inappropriate processes and a mechanism that could avoid this path would therefore be advantageous. Transport through an organelle, moving Ca^{2+} from its entry point to its target, would solve this problem (Fig. 1). The process of Ca^{2+} tunnelling through the ER was discovered in studies on pancreatic acinar cells carried out 20 years ago (Mogami *et al.* 1997). A similar process was later described in dopamine neurons (Choi *et al.* 2006) and the whole concept has more recently been generalized, based on experiments in oocytes (Courjaret & Machaca, 2014; Courjaret *et al.* 2016a). Furthermore, in a recent study (Kar *et al.* 2016), it has been shown that Ca^{2+} refilling of the

nuclear envelope, after inositol trisphosphate (IP₃)-evoked Ca²⁺ release into the nucleoplasm through the inner nuclear membrane (Gerasimenko *et al.* 1995), depends on Ca²⁺ (entering via store-operated Ca²⁺ channels) being tunneled through the ER lumen directly into the nuclear envelope. In this article, we describe and review the most important evidence for Ca²⁺ tunnelling, primarily based on studies of pancreatic acinar cells and oocytes.

Spatial and temporal features of Ca²⁺ signals

Specificity in Ca²⁺ signals is encoded in their spatial, temporal and amplitude features. These Ca²⁺ dynamics combine to activate a defined subset of Ca²⁺-dependent downstream effectors to transduce the cellular response (Berridge *et al.* 2000, 2003). Spatially, Ca²⁺ signals are tightly regulated and are typically initiated by elementary events due to the opening of Ca²⁺ channels (intracellular or at the cell membrane). These elementary events due to the opening of one or a few channels can either remain localized resulting in Ca²⁺ signals in the microdomain around the channel(s), or coalesce through complex mechanisms into more global Ca²⁺ events that often encompass the entire cell (Berridge, 1997).

The extent and speed of Ca²⁺ movement is heavily influenced by the concentration and characteristics of the available Ca²⁺ buffers. It was shown many years ago, that adding a low affinity mobile Ca²⁺ buffer to the cytosol can profoundly change the timing and spatial extension of agonist-elicited cytosolic Ca²⁺ signals (Petersen *et al.* 1991). The cytosolic Ca²⁺ buffering characteristics vary markedly between different cell types with, for example, a high level of relatively low mobility buffer in pancreatic acinar cells (Mogami *et al.* 1999), and a less restricted environment for Ca²⁺ diffusion in oocytes (Allbritton *et al.* 1992) and some nerve cells (Lin *et al.* 2017). Inevitably, [Ca²⁺] measurements using Ca²⁺-sensitive fluorescent probes will be influenced by the Ca²⁺-binding properties of the probes, so unless a careful analysis of the Ca²⁺

buffering situation has been carried out, as recently described by Lin *et al.* (2017), some caution with regard to interpreting quantitative results is called for.

In general, the diffusion of Ca²⁺ in the cytosol is always severely limited, as compared to movement in water, due to the relatively high buffering capacity. Some estimates indicate that free Ca²⁺ diffuses < 0.1 μm, and is free for ~0.5 μs before it is buffered (Allbritton *et al.* 1992; Kasai & Petersen, 1994). At the mouth of an open Ca²⁺ channel and given the great concentration gradients across both the ER and plasma membrane, Ca²⁺ flow rapidly overwhelms the local buffering capacity resulting in a microdomain of high Ca²⁺ concentration in the order of 20–200 μM (Rizzuto & Pozzan, 2006). The spatial spread of these high Ca²⁺ microdomains is thus very tightly controlled, and is predicted based on theoretical modelling to be maintained within 20 nm of the channel (Simon & Llinas, 1985; Neher, 1998). Beyond the immediate point source of Ca²⁺ entry at the mouth of the channel, Ca²⁺ diffusion creates a downward gradient away from the channels that is thought to dissipate to the submicromolar range within 200 nm of the channel (Neher, 1998; Shuai & Parker, 2005; Demuro & Parker, 2006). This provides for an elegant mechanism to activate Ca²⁺-dependent effectors that localize within the spatial spread of Ca²⁺ signals generated due to elementary Ca²⁺ events (Rizzuto & Pozzan, 2006; Parekh, 2008).

Global Ca²⁺ signals, in contrast, have a significantly broader spread on the order of 10–100 μm. This highlights a spatial gap between elementary and global Ca²⁺ signals, as there could be a physiological need to activate effectors that are not in the immediate vicinity of a Ca²⁺ channel without inducing a global Ca²⁺ rise that would activate a multitude of other signalling pathways. Although not discussed in details here, cells could maintain specificity in their Ca²⁺ signals despite the extent of their spatial spread by controlling their amplitude and frequency for example. Nonetheless, there are several examples that argue that Ca²⁺ signals activate effectors in the

Figure 1. Schematic drawing of Ca²⁺ movement through pancreatic acinar cells

Ca²⁺ moves from the extracellular solution (extreme right) via store-operated CRAC channels, SERCA pumps, ER, IP₃R and PMCA pumps into the acinar lumen (extreme left). Diffusion of Ca²⁺ from the base of the cell to the apical pole occurs quantitatively inside the ER rather than in the cytosol because of the much higher Ca²⁺ binding capacity in the cytosol than in the ER lumen. Ca²⁺ released from the ER in the apical part of the cell via IP₃R activates Cl⁻ channels (ANO1) in the luminal acinar plasma membrane. ANO1, anoctamin-1; CRAC channel, Ca²⁺ release-activated Ca²⁺ channel; IP₃R, inositol trisphosphate receptor; PMCA, plasma membrane Ca²⁺-activated ATPase; SERCA, sarco/endoplasmic reticulum Ca²⁺ activated ATPase.

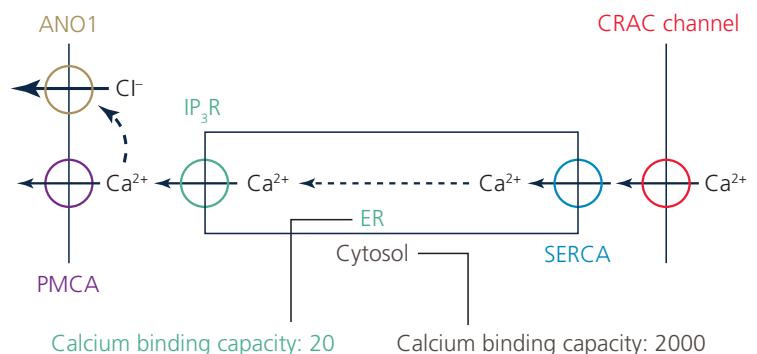

mid-range, between the microdomain and global spatial extremes, with exquisite specificity. Nuclear factor of activated T-cells (NFAT) activation in T-cells in response to antigen stimulation (Dolmetsch *et al.* 1997; Rao *et al.* 1997), Ca^{2+} -activated K^+ channels (Liu *et al.* 1998), and Ca^{2+} -activated Cl^- channels (Courjaret & Machaca, 2014) are examples of effectors activated specifically without localizing to the Ca^{2+} channel microdomain. It is, however, not clear mechanistically how cells would mediate such Ca^{2+} signals in the mid-range without inducing a global Ca^{2+} rise. One possible mechanism is to induce a higher level or a more sustained Ca^{2+} flux through open channels to saturate the local buffering capacity, thus allowing the Ca^{2+} signal to spread further. This would be a perilous path, though, given the Ca^{2+} dependence of intracellular Ca^{2+} release channels, IP_3 and ryanodine receptors, which could lead to Ca^{2+} -induced Ca^{2+} release and a global Ca^{2+} rise (Osipchuk *et al.* 1990; Bootman *et al.* 2002).

Ca^{2+} signalling in electrically non-excitabile cells is typically initiated downstream of agonist stimulation through the activation of a phospholipase C that hydrolyses phosphatidyl inositol bisphosphate (PIP_2) at the plasma membrane and results in the production of IP_3 and diacylglycerol. IP_3 diffuses and gates open IP_3 receptors at the ER membrane, releasing store Ca^{2+} to mediate the first phase of the Ca^{2+} signal. Should the Ca^{2+} release phase result in significant store depletion, it leads to the activation of Ca^{2+} influx at the plasma membrane through store-operated Ca^{2+} entry (SOCE). SOCE is mediated by members of the stromal interaction molecule (STIM) and Orai family (Prakriya & Lewis, 2015). STIM1 is a single-pass ER membrane protein with luminal EF hands allowing it to sense the ER Ca^{2+} concentration (Liou *et al.* 2005; Roos *et al.* 2005). Store depletion results in STIM1 losing its luminal bound Ca^{2+} leading to a conformational change in the protein and its clustering and translocation to ER–plasma membrane (PM) junctions that are 20 nm apart (Luik *et al.* 2006; Prakriya *et al.* 2006; Stathopoulos *et al.* 2006; Vig *et al.* 2006; Wu *et al.* 2006; Yeromin *et al.* 2006; Liou *et al.* 2007). The close proximity of the ER and PM at these junctions allows STIM1 to span the distance and physically interact with Orai1 at the PM. Orai1 is a four transmembrane domain protein that forms a hexameric channel that is exquisitely Ca^{2+} selective (Hou *et al.* 2012). STIM1 clusters stabilize at ER–PM junctions initially through interaction of the poly-lysine domain at the C-terminal end of STIM1 with PIP_2 in the PM. Activated STIM1 in response to store depletion exposes the STIM1 Orai1-activating region (SOAR)/CRAC-activating domain, which interacts with Orai1, traps it within the STIM1-defined ER–PM junctions, and gates it open, thus allowing Ca^{2+} flow into the cell. SOCE activation not only results in store refilling but also shapes Ca^{2+} signal dynamics. There is therefore a tight functional link

between IP_3 -dependent Ca^{2+} release in response to agonist stimulation and Ca^{2+} influx through SOCE.

Ca^{2+} tunnelling in pancreatic acinar cells

The function of the acinar cells. The principal function of the exocrine pancreas is to deliver digestive enzymes to the intestine in order to break down food products, so that they can be absorbed into the circulation. The most important secretory cell in the exocrine pancreas is the acinar cell, which manufactures the inactive pro-enzymes and stores them in zymogen granules. When enzyme delivery is required, the acinar cells receive a signal in the form of either the neurotransmitter acetylcholine (ACh; released from parasympathetic nerve endings) and/or the hormone cholecystokinin (CCK). Interaction with specific surface membrane receptors activates signal transduction mechanisms that generate intracellular Ca^{2+} , liberating messengers – IP_3 in the case of ACh and cyclic ADP-ribose and nicotinic acid adenine dinucleotide phosphate (NAADP) in the case of CCK stimulation – thereby releasing Ca^{2+} from intracellular stores (Petersen & Tepikin, 2008). As a consequence of the depletion of intracellular Ca^{2+} stores, Ca^{2+} -permeable channels in the plasma membrane are opened allowing Ca^{2+} entry from the extracellular solution (Petersen & Tepikin, 2008).

Under physiological conditions the cytosolic Ca^{2+} concentration ($[\text{Ca}^{2+}]_i$) changes evoked by ACh or CCK consist of repetitive short-lasting elevations mostly confined to the apical region (Kasai *et al.* 1993; Thorn *et al.* 1993), where the zymogen granules are concentrated. This local rise in $[\text{Ca}^{2+}]_i$ triggers exocytosis of the granule content (Maruyama & Petersen, 1994) as well as opening up Cl^- channels in the apical membrane and K^+ channels in the apical part of the lateral membrane (Petersen & Maruyama, 1984; Petersen, 1992; Park *et al.* 2001b). These channel openings enable operation of the $\text{Na}^+/\text{K}^+/\text{2Cl}^-$ co-transporter as well as increased turnover of the Na^+/K^+ pump across the basolateral membrane (Petersen, 1992). The net result is uptake of Cl^- across the basolateral membrane and secretion of Cl^- across the apical membrane with Na^+ following via a paracellular pathway through the leaky tight junctions. Water moves along with the salt both through the cell and through the so-called tight junctions (Petersen, 1992). The Ca^{2+} -activated acinar fluid secretion is a vehicle for transport of the pro-enzymes into the duct system, where an additional ductal fluid secretion of a secretin-stimulated bicarbonate-rich solution (Scratcherd *et al.* 1981; Lee *et al.* 2012) will help wash the pro-enzymes into the gut where they become active digestive enzymes.

The polarity of the acinar cells. The acinar cells secrete enzymes and fluid in one direction, namely into the lumen of the acinar unit, which is directly connected to the duct

system and, therefore, these cells are highly polarized. The zymogen granules are in the apical part of the cells, whereas the nucleus – surrounded by densely packed rough ER – occupies the basolateral region. The apical membrane area is much smaller than the basolateral membrane area, but the final stage of secretion occurs exclusively through the apical membrane. The tight junctions, which are leaky in the case of the acinar epithelium, are placed close to the acinar lumen. Although the bulk of the ER is in the basolateral region, ER elements penetrate into the apical zymogen granule-rich region all the way to the apical membrane (Gerasimenko *et al.* 2002).

With regard to the localization of the principal Ca²⁺-activated ion channels in the plasma membrane of the acinar cells, we know that the Ca²⁺-activated Cl⁻ channels, transmembrane member 16A (TMEM16A)/anoctamin-1 (ANO1) (Lee *et al.* 2012), are exclusively present in the apical membrane (Park *et al.* 2001*b*), whereas the high-conductance and voltage-sensitive Ca²⁺-activated K⁺ channels (present in the pig and human acinar cells) are found in the basolateral membrane (Maruyama *et al.* 1983; Petersen *et al.* 1985). Simultaneous patch clamp recording of Cl⁻ conductance and capacitance indicate that during normal physiological stimulus–secretion coupling, each local apical Ca²⁺ spike causes near-synchronous (but see below) opening of Cl⁻ channels and exocytosis (Maruyama & Petersen, 1994).

With regard to Ca²⁺ transport across the plasma membrane, we know that Ca²⁺-ATPase-driven Ca²⁺ extrusion occurs mostly through the apical membrane (Belan *et al.* 1996), whereas store-operated Ca²⁺ entry occurs through the basolateral membrane (Mogami *et al.* 1997; Park *et al.* 2001*a*; Lur *et al.* 2009).

How Ca²⁺ entering through the basolateral plasma membrane allows Ca²⁺ signal generation near the apical membrane without passing through the cytosol.

Although it has been known from the earliest days of work on stimulus–secretion coupling in pancreatic acinar cells that the initial Ca²⁺ signal generation evoked by stimulation with either ACh or CCK is due to release of Ca²⁺ from internal stores (Matthews *et al.* 1973; Petersen & Ueda, 1976), it has also been clear that supply of Ca²⁺ from the extracellular solution is essential for continuation of secretion (Petersen & Ueda, 1976). The reason for the extracellular Ca²⁺ requirement is that every rise in the cytosolic Ca²⁺ concentration ([Ca²⁺]_i) inevitably activates Ca²⁺ pumps in the plasma membrane (plasma membrane Ca²⁺-activated ATPase; PMCA) resulting in extrusion of Ca²⁺ (Tepikin *et al.* 1992), which then has to be compensated by Ca²⁺ entry, as otherwise the cell would gradually run out of Ca²⁺.

Agonist-elicited cytosolic Ca²⁺ spiking, which is the normal physiological signal for secretion, requires a relatively high [Ca²⁺]_i in the lumen of the ER (Park *et al.*

2000). In experiments on isolated acinar cells where [Ca²⁺]_i changes in both the cytosol and the lumen of the ER were measured simultaneously, it could be shown that ACh evokes cytosolic Ca²⁺ spiking for several minutes in the absence of external Ca²⁺. However, spiking subsequently stops after only a relatively modest reduction of [Ca²⁺]_{ER} (Park *et al.* 2000). Thus, Ca²⁺ entry through store-operated Ca²⁺ channels, refilling the ER store, is essential for the normal physiological function of the acinar cells.

The original concept of Ca²⁺ tunnelling through the ER lumen, from entry at the base of the cell to release near the apical membrane (Fig. 1), was based on experiments in which isolated acinar cells were kept in a Ca²⁺-free solution with a patch pipette attached to the basal surface (Mogami *et al.* 1997). The patch pipette was filled with a Ca²⁺-containing solution and Ca²⁺ entry across the membrane covered by the pipette tip could be regulated by controlling the pipette potential. After supra-maximal ACh stimulation had emptied the intracellular stores during a period without Ca²⁺ entry (negative – retaining – potential in the pipette), ACh stimulation was discontinued and a period of Ca²⁺ entry was enabled by switching the pipette potential from negative to positive. No change was observed in [Ca²⁺]_i during this Ca²⁺ entry period, but after discontinuation of Ca²⁺ entry (switching the pipette voltage back to negative), a new period of ACh stimulation caused a local rise of [Ca²⁺]_i in the apical pole near the apical membrane, exactly as under normal conditions. A rise in [Ca²⁺]_i near the cell-attached pipette during Ca²⁺ entry could only be observed when the ER Ca²⁺ pumps (sarco/endoplasmic reticulum Ca²⁺-activated ATPase; SERCA) were arrested by thapsigargin (Thastrup *et al.* 1989). However, in this situation there was no sign of transfer of Ca²⁺ from the base to the apex, as ACh stimulation after a period of Ca²⁺ entry failed to elicit any Ca²⁺ release in the apical region (Mogami *et al.* 1997). As thapsigargin is a very selective blocker of SERCA pumps (Thastrup *et al.* 1989), the simplest explanation for the phenomenon observed, namely the non-cytosolic transfer of Ca²⁺ across the cell from base to lumen, is movement through the ER lumen.

The ER Ca²⁺ tunnelling concept (Mogami *et al.* 1997) assumed that Ca²⁺ would move more easily within the lumen of the ER than in the cytosol (Fig. 1). The relatively low mobility of Ca²⁺ in the cytosol was demonstrated in the classical experiments of Baker & Crawford (1972) on axoplasm, in which it could be shown that radioactive Mg²⁺ moved much more quickly than radioactive Ca²⁺, and later confirmed by Allbritton *et al.* (1992). In the acinar cells, based on measurements of absolute calcium movements and changes in [Ca²⁺]_i in the cytosol and the ER, we estimated that the calcium binding capacity in the ER lumen is about 20 whereas in the cytosol it is about 1500–2000 (Mogami *et al.* 1999). Thus the mobility of

Ca^{2+} in the ER lumen is very much higher than in the cytosol (Fig. 1).

The high mobility of Ca^{2+} in the ER lumen was demonstrated directly by experiments in which changes in $[\text{Ca}^{2+}]_{\text{ER}}$ at various locations in the ER could be monitored after a highly localized uncaging of caged Ca^{2+} in the ER lumen (Park *et al.* 2000). These experiments showed that after a local Ca^{2+} uncaging event, rises in $[\text{Ca}^{2+}]_{\text{ER}}$ were observed quickly over considerable distances (more than 10 μm away from the site of uncaging) and that the whole of the ER was re-equilibrated with regard to $[\text{Ca}^{2+}]_{\text{ER}}$ within a few seconds (less than the time interval between cytosolic Ca^{2+} spikes during physiological Ca^{2+} signalling) (Park *et al.* 2000; Petersen *et al.* 2001).

Movement of Ca^{2+} from the extracellular fluid into the ER lumen at the base. Early work on perfused submandibular glands showed that ACh-evoked intracellular Ca^{2+} release was followed, after a delay, by Ca^{2+} influx into the gland cells from the perfusion fluid (Nielsen & Petersen, 1972). Later, work on isolated pancreatic acinar cells showed more precisely that the Ca^{2+} entry, following the ACh-evoked immediate (< 0.5 s) apical Ca^{2+} release, occurred through the basolateral membrane after a delay of about 6–7 s (Toescu & Petersen, 1995). A few years later it was shown that it is possible to refill the emptied ER with Ca^{2+} flowing into the cell from a point source at the base of the cell (Mogami *et al.* 1997). Like in many other cell types, store-operated Ca^{2+} entry is mediated by translocation of STIM to puncta near the plasma membrane, which in the pancreatic acinar cells are specifically located at the basolateral part of the cell (Lur *et al.* 2009). However, in these cells there is a specific challenge for this process, as the ER is of the rough type due to the presence of ribosomes. The size of ribosomes is such that it would not allow the close molecular interaction between STIM in the ER membrane and Ca^{2+} channels in the plasma membrane that is necessary for channel activation. However, it turns out that there are small areas of the otherwise rough ER that are devoid of ribosomes, allowing these parts to come very close to the plasma membrane (Lur *et al.* 2009) (Fig. 2).

The biophysical nature of the Ca^{2+} entry process in the pancreatic acinar cells was not clarified until recently (Gerasimenko *et al.* 2013), when patch clamp whole-cell current recording studies showed that the inward Ca^{2+} current evoked by ER store Ca^{2+} depletion has characteristics very similar to the Ca^{2+} release activated Ca^{2+} (CRAC) current previously discovered in immune cells (Hoth & Penner, 1992; Feske, 2007; Parekh, 2010), and could be blocked by a specific CRAC channel inhibitor (Gerasimenko *et al.* 2013). During Ca^{2+} refilling of the ER, for example after ACh-evoked emptying of the store, there is no measurable increase in the cytosolic Ca^{2+} concentration near the Ca^{2+} entry channels although,

as mentioned above, it is possible to observe a rise in the cytosolic $[\text{Ca}^{2+}]$ during Ca^{2+} entry if the SERCA pumps in the ER have been arrested by thapsigargin (Mogami *et al.* 1997). In that case there is also a clear increase in the $[\text{Ca}^{2+}]$ in the mitochondria (mitochondrial Ca^{2+} uptake being mediated by the mitochondrial Ca^{2+} uniporter; MCU; De Stefani *et al.*, 2011, 2016) placed very close to the basolateral membrane (Park *et al.* 2001a) (Fig. 2). Ca^{2+} uptake into these peripheral mitochondria is functionally important as it will increase ATP production (De Stefani *et al.* 2016) locally, thereby fuelling the SERCA pumps. It would therefore appear that the crucial molecules, involved in the process of moving Ca^{2+} from the extracellular fluid into the ER, namely CRAC channels, SERCA pumps and the MCU, are localized very close together in the basolateral part of the cell during SOCE (Fig. 2).

Movement of Ca^{2+} from the ER into the apical cytosol where activation of exocytosis and Cl^- channels occurs. The rise in $[\text{Ca}^{2+}]_i$, evoked by either ACh or CCK

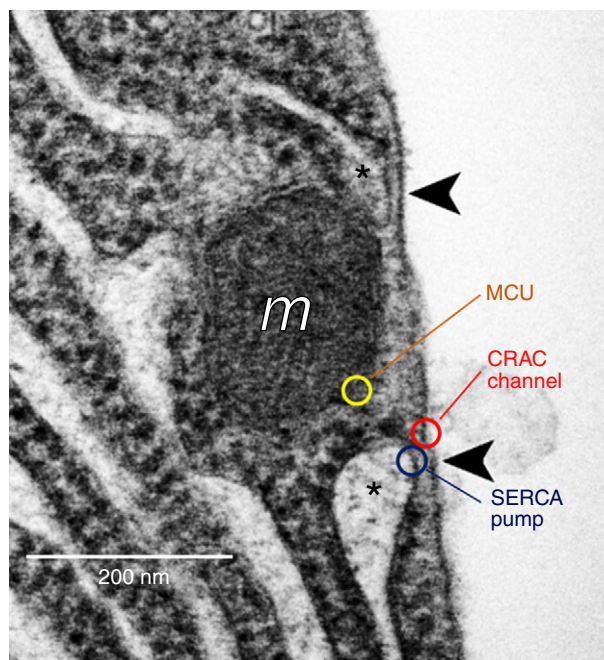

Figure 2. Location of key organelles and molecules involved in Ca^{2+} uptake at the base of pancreatic acinar cells

EM picture of basal area of a pancreatic acinar cell showing areas in which the ER is devoid of ribosomes and comes very close to the plasma membrane (indicated with asterisk). This arrangement allows molecular interaction between STIM in the ER membrane and CRAC channels in the plasma membrane. A mitochondrion (*m*) is also seen near the plasma membrane. Arrowheads signpost ER–plasma membrane junctions where Ca^{2+} entry can take place. Indicative locations of the three key Ca^{2+} transporters at the base of the cell are shown. MCU, mitochondrial Ca^{2+} uniporter. Adapted from Lur *et al.* (2009).

stimulation, always starts in the apical part of the cell, close to the apical membrane (Kasai & Augustine, 1990; Kasai *et al.* 1993; Thorn *et al.* 1993; Cancela *et al.* 2000) and, at near-physiological intensities of stimulation, the rise is mostly confined to the apical region (Kasai *et al.* 1993; Thorn *et al.* 1993), due to the perigranular mitochondrial firewall (Tinel *et al.* 1999; Park *et al.* 2001a). Even under conditions where muscarinic receptor activation occurs exclusively within a small region at the base of the cell (uncaging of caged carbachol in a cell-attached patch pipette), the rise in [Ca²⁺]_i always starts near the apical membrane (Ashby *et al.* 2003). Close comparison of the time course of the increases in Cl⁻ conductance and capacitance (indicative of fusion between zymogen granules and apical plasma membrane) during individual apical Ca²⁺ spikes shows (Fig. 3) that Cl⁻ channels are activated slightly earlier than the start of exocytosis and that the Cl⁻ conductance increase slightly outlasts the period of increased capacitance (Maruyama & Petersen, 1994). This could be explained either by the Cl⁻ channels being located closer to the ER Ca²⁺ release channels than the sites of exocytosis, or by the Cl⁻ channels being more sensitive to the local [Ca²⁺]_i changes than the exocytosis machinery.

Ca²⁺ spiking, induced by stimulation with either ACh or CCK, is abolished by blockade of IP₃ receptors (IP₃Rs) (Wakui *et al.* 1990), but also by blockade of ryanodine receptors (RyRs) (Cancela *et al.* 2000). Since Ca²⁺ spiking can also be elicited by intracellular Ca²⁺ infusion (Osipchuk *et al.* 1990; Wakui *et al.* 1990), it is probably due to interactive Ca²⁺-induced Ca²⁺ release,

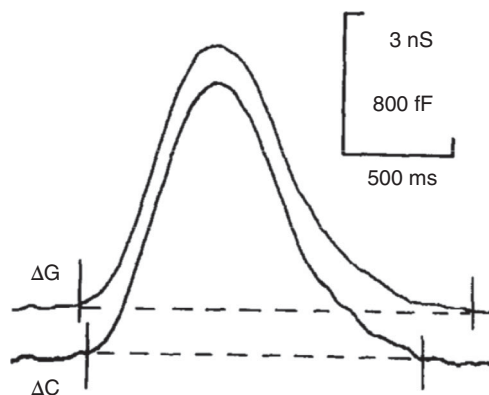

Figure 3. Ca²⁺-activated secretory events at the apical pole of pancreatic acinar cells

Simultaneous recording of changes in Cl⁻ conductance (ΔG) and capacitance (ΔC) during a single IP₃-elicited Ca²⁺ spike (part of a train of spikes evoked by continuous intracellular IP₃ infusion) shows the similar timing and trend of both events with a slight delay in the capacitance increase as compared to the rise of the Cl⁻ conductance. It is also seen that the Cl⁻ conductance increase outlasts the period of increased capacitance. From Maruyama & Petersen (1994).

involving both IP₃Rs and RyRs. The mechanisms by which ACh and CCK initiate apical Ca²⁺ signal generation are different. In the case of ACh stimulation, there is IP₃ generation due to phospholipase C activation whereas in the case of physiological CCK stimulation (low picomolar CCK concentration), there is primary generation of NAADP (Yamasaki *et al.* 2005). Thus blockade of NAADP receptors inhibits CCK- but not ACh-elicited Ca²⁺ spiking (Cancela *et al.* 2000; Gerasimenko *et al.* 2015). In spite of these mechanistic differences, the measurable Ca²⁺ signal progression from the initiation site near the apical membrane towards the perigranular mitochondrial belt is quantitatively very similar in both cases (Cancela *et al.* 2000). This indicates that the initial trigger Ca²⁺ release is so small and so local that it is not observable with current technology. The local apical Ca²⁺ release that actually activates the Cl⁻ channels in the apical membrane and the exocytotic enzyme release through the apical plasma membrane is therefore most likely the result of the final co-activation of IP₃Rs and RyRs triggered by the initial Ca²⁺ release from either IP₃Rs or NAADP-sensitive two-pore channels (Gerasimenko *et al.* 2015).

Ca²⁺ tunnelling supports mid-range Ca²⁺ signalling in the *Xenopus* oocyte

The *Xenopus* oocyte as an experimental model system to study Ca²⁺ signalling. The frog oocyte has long been a favoured model system to study Ca²⁺ signalling and has contributed significantly to our understanding of basic Ca²⁺ signalling mechanisms, including elementary Ca²⁺ release events, Ca²⁺ waves, fertilization-specific Ca²⁺ signals, biophysical properties of the IP₃ receptor, and remodelling of Ca²⁺ signalling during the cell cycle (Lechleiter & Clapham, 1992; Sun *et al.* 1998; Bugrim *et al.* 2003; Foskett *et al.* 2007; Machaca, 2007). Several features make the oocyte an attractive model system to study these various aspects of Ca²⁺ signalling. The oocyte is large (~1.2 mm in diameter) allowing for easy spatial resolution of Ca²⁺ dynamics, which becomes particularly important for studies focused on the generation and propagation of Ca²⁺ waves, and elementary Ca²⁺ release events because their large spatial footprint in the oocyte makes them more amenable to investigation. The size of the oocyte also favours biochemical analyses and importantly linking them directly to Ca²⁺ signalling and other cell physiological processes at the single cell level (Machaca & Haun, 2002). Another unique advantage of the oocyte is the stage of the cell cycle oocytes transition through with two physiologically defined arrest points at prophase I and metaphase II of meiosis. Oocytes are arrested in prophase I at the G2/M transition of the cell cycle in a G2-like state, which is the typical stage in which they have been used as an experimental model. However, physiologically oocytes transition to metaphase of meiosis

II in preparation for fertilization. This well-regulated progression through M-phase provides a distinctive window into the cell division phase of the cell cycle that is transient and asynchronized in other systems such as mitosis in mammalian cells, making it more difficult to study. Another additional benefit of the oocyte is the relative simplicity of its Ca^{2+} signalling toolkit compared to other cells. The frog oocyte has a limited well defined complement of Ca^{2+} channels and transporters, significantly less complex than most mammalian cells (Machaca, 2007).

Further simplifying Ca^{2+} signalling studies in the frog oocyte is the endogenous expression of Ca^{2+} -activated Cl^- channels (CaCCs), which are critical for oocyte biology and fertilization as they contribute significantly to the maintenance and regulation of the membrane potential. The Ca^{2+} transient generated at fertilization is initially localized at the site of sperm entry but gradually sweeps across the entire egg in the form of a Ca^{2+} release wave, which activates CaCCs and depolarizes the cell to prevent polyspermy (Machaca *et al.* 2001). This so called 'fast electrical block' to polyspermy in *Xenopus* is due to the fact that sperm-egg fusion is voltage sensitive in this species (Jaffe *et al.* 1983; Goul-Somero & Jaffe, 1984). The molecular entity underlying the CaCC in the frog oocyte has been identified as anoctamin 1 (Ano1) or TMEM16A (Schroeder *et al.* 2008; Yang *et al.* 2008). The biophysical properties of the *Xenopus* oocyte CaCCs have been well characterized both for the endogenous current (Kuruma & Hartzell, 1998, 2000; Machaca & Hartzell, 1998, 1999; Callamaras & Parker, 2000), over-expressed Ano1 in the oocyte (Courjaret *et al.* 2016b),

and heterologously expressed *Xenopus* Ano1 in the axolotl oocyte (Schroeder *et al.* 2008). In the oocyte, CaCC senses sub-cell membrane changes in Ca^{2+} concentration in real time and with high fidelity, whether this Ca^{2+} is released from the ER or flows from the extracellular space through channels in the plasma membrane (Machaca & Hartzell, 1999). As such multiple studies have used the endogenous CaCC to monitor complex Ca^{2+} dynamics mediated by endogenous or heterologously expressed Ca^{2+} -permeable channels, such as ionotropic receptors (Kuruma & Hartzell, 1998), voltage-gated Ca^{2+} channels (Zhou *et al.* 2004), transient receptor potential (TRP) channels (Courjaret *et al.* 2013) and SOCE channels (Courjaret & Machaca, 2016).

Mid-range Ca^{2+} signalling. While studying the activation properties of CaCCs in the frog oocyte in response to various Ca^{2+} mobilizing agents, we noticed that CaCCs are stimulated to significantly higher levels when stores are depleted with IP_3 as compared to other mobilizing agents that deplete Ca^{2+} stores by distinct mechanisms of action, including ionomycin, (*N,N,N,N*-tetrakis(2-pyridylmethyl)-ethylenediamine (TPEN) and thapsigargin (Fig. 4A) (Courjaret & Machaca, 2014). While IP_3 replicates the physiological situation, ionomycin, a Ca^{2+} ionophore with preferential insertion in the ER membrane (Morgan & Jacob, 1994), empties Ca^{2+} stores rapidly and induces SOCE in the absence of activation of IP_3 receptors (IP_3R). TPEN is a transition metal chelator with low Ca^{2+} affinity that is freely membrane permeant and chelates high luminal ER Ca^{2+} , thus simulating Ca^{2+} store depletion and inducing

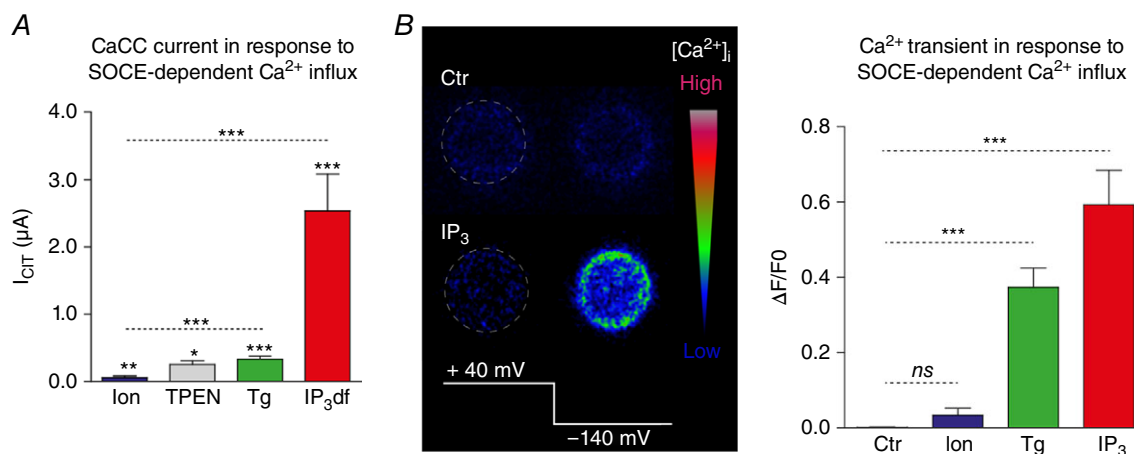

Figure 4. Differential response of Ca^{2+} -activated Cl^- channels to modes of store depletion in the oocyte A, amplitudes of current through CaCC following store depletion with different agents: ionomycin, TPEN, thapsigargin (Tg), non-hydrolyzable IP_3 (IP_3df). B, left, intracellular Ca^{2+} transient monitored by confocal microscopy in a voltage-clamped oocyte using Oregon green BAPTA-1 under control conditions (Ctr) or following IP_3 injection. Ca^{2+} influx through SOCE was stimulated by hyperpolarizing the cell to -140 mV. Right, summary of the intracellular Ca^{2+} rise induced by the hyperpolarizing pulse to -140 mV when intracellular stores were depleted with ionomycin (Ion), thapsigargin (Tg) or IP_3 . Adapted from Courjaret and Machaca (2014).

SOCE (Hofer *et al.* 1998), again in the absence of IP₃R activation. Thapsigargin is an irreversible, specific blocker of the endoplasmic reticulum Ca²⁺-ATPase (SERCA) (Thastrup *et al.* 1989) that leads to store depletion due to an inherent constitutive Ca²⁺ leak pathway from the ER. Therefore, blocking SERCA, the primary ER Ca²⁺ refilling pathway leads to store depletion, although with slower kinetics than other aforementioned Ca²⁺ mobilizing agents. Given the differing mechanisms by which these agents induce SOCE, it was not clear why IP₃ leads to a significantly higher induction of current through CaCCs. We ruled out an increased Ca²⁺ influx through SOCE under these various conditions (Courjaret & Machaca, 2014). Furthermore, we showed that Ca²⁺ transients in the cortical region of the oocyte were of similar amplitude when SOCE was stimulated with IP₃ or thapsigargin, but of much smaller amplitude with ionomycin (Fig. 4B) (Courjaret & Machaca, 2014). Given that measuring SOCE current reveals similar flow of Ca²⁺ into the cell, these data show that when SERCA is active, Ca²⁺ flowing through SOCE channels is immediately taken up by SERCA into the ER lumen, thus preventing its diffusion

into the cortical region. When SERCA is blocked with thapsigargin, this pathway is inhibited allowing SOCE to flood the cell cortex with Ca²⁺. However, this does not explain why cortical Ca²⁺ is high during the Ca²⁺ influx phase when stores are depleted with IP₃ (Fig. 4B). Various approaches to block the IP₃R or SERCA were used to show that the high CaCC current in response to SOCE when IP₃ is present requires active IP₃Rs (Courjaret & Machaca, 2014). This led to the model outlined in Fig. 5, where Ca²⁺ flowing through SOCE channels is taken up within the SOCE microdomain by SERCA into the ER lumen and then released through open IP₃Rs at a distal site to specifically activate CaCCs, thus leading to high current levels specifically in response to SOCE (Fig. 5). This model matches the Ca²⁺ tunnelling mechanism discussed above in pancreatic acinar cells although the timing and functional links between the various components of the pathway diverge to meet the cell's physiological needs.

Careful co-localization experiments in the oocyte confirm this model and show that Orai1, STIM1 and SERCA localize to the SOCE clusters at ER–PM junctions,

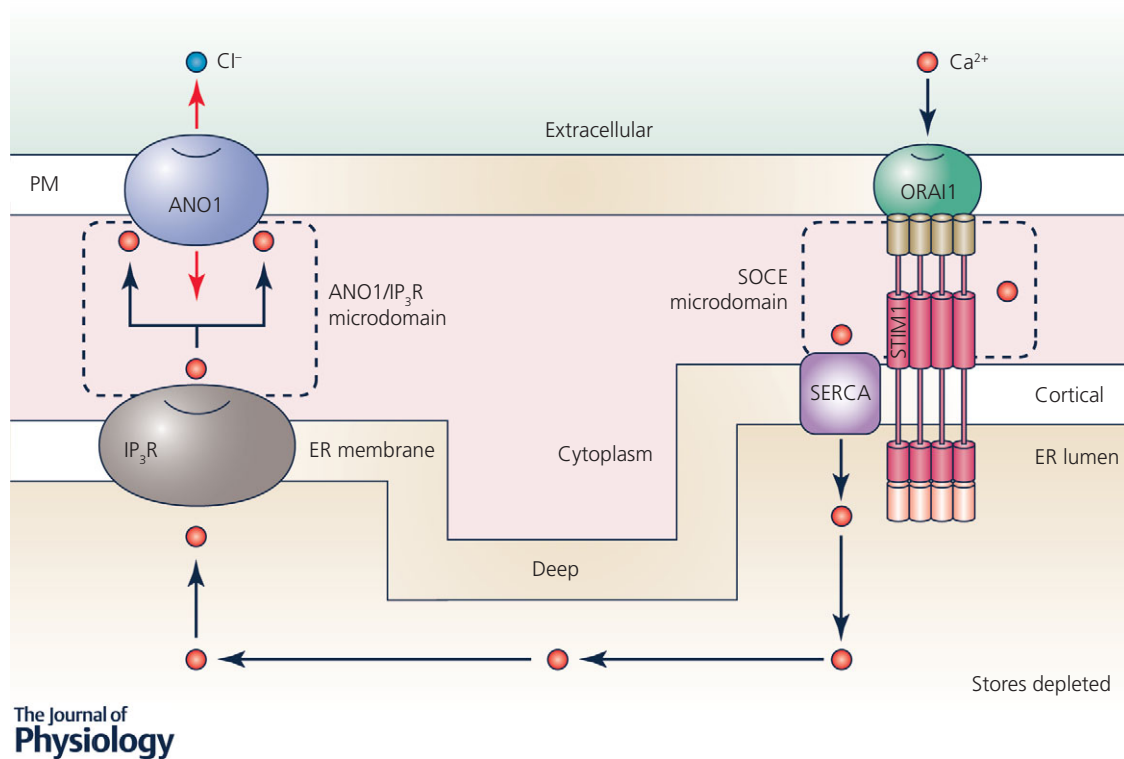

Figure 5. Model of Ca²⁺ tunnelling

Cartoon depicting the mechanism of Ca²⁺ tunnelling downstream of Ca²⁺ store depletion and SOCE activation. Two distinct separate microdomains are at play. The SOCE microdomain, defined by STIM1–Orai1 interactions, mediates Ca²⁺ flow from the extracellular space into the narrow ER–PM junction where it is taken up into the ER through the action of SERCA. The second domain is defined by IP₃R release sites that localize close to CaCCs to selectively activate them. Ca²⁺ flows from the extracellular space through Orai1 resulting in a localized Ca²⁺ microdomain that is spatially limited due to rapid uptake of Ca²⁺ by SERCA into the ER lumen. With open IP₃Rs, Ca²⁺ flowing into the ER leaks out through IP₃R to activate CaCC.

thereby creating a specialized Ca^{2+} handling domain that favours Ca^{2+} influx into the cytoplasm through Orai1 and uptake into the ER through SERCA (Courjaret & Machaca, 2014). Importantly, in the case of CaCC as a downstream Ca^{2+} effector, store depletion is associated with a dramatic remodelling of the Ca^{2+} signalling machinery. STIM1, Orai1 and SERCA localize to SOCE clusters at ER–PM junctions. In contrast, Ano1 is excluded from these junctions and localizes to other areas of the plasma membrane (Fig. 6). At rest, Ano1 is evenly distributed throughout the cell membrane of the oocyte, including the dense brush of microvilli where it serves an additional scaffolding function and regulates microvilli length (Courjaret *et al.* 2016*b*). Store depletion, while concentrating STIM1, Orai1 and to a lesser extent SERCA into the SOCE clusters, excludes Ano1 resulting in the patchy separation illustrated in Fig. 6. In other words, there is little to no co-localization of the Ca^{2+} entry source (SOCE) and of the Ca^{2+} effector (CaCC), and the distance to be covered by Ca^{2+} ions in the cytoplasm from the mouth of the Orai channel to the CaCC is incompatible with a diffusion mechanism given the speed of activation of CaCCs and the measured size and distribution of SOCE puncta as compared to CaCC-rich membrane domains (Fig. 6). To overcome the diffusion barrier and reach the CaCCs, Ca^{2+} ions transit through the ER and are released at the target spot by IP_3R . This spatial reorganization of the Ca^{2+} signalling machinery mediating SOCE and Ca^{2+} release results in the delivery of Ca^{2+} flowing into the cell through SOCE to a distal effector, CaCC, without inducing a global Ca^{2+} rise or having to contend with the limiting cytoplasmic Ca^{2+} diffusion. This signalling module allows for the transport of information carried by Ca^{2+} influx across distances that exceed the SOCE microdomain and are in the micrometre range or ‘mid-range’ between elementary and global signals.

Therefore, with SERCA active, the cytoplasmic Ca^{2+} transient within SOCE puncta at ER–PM junctions is

transient and very localized, with the majority of the Ca^{2+} flux going into the ER and then leaking out at distal sites through IP_3Rs to activate effectors with high specificity and efficiency. This is consistent with the small flux through Orai1 channels. Localization of SERCA to the STIM/Orai cluster is not restricted to *Xenopus* oocytes and has been reported in other cell types (Jousset *et al.* 2007; Sampieri *et al.* 2009; Alonso *et al.* 2012; Hogan, 2015). Therefore, following store depletion and the activation of SOCE, a pump–leak balance develops at the ER membrane with a point source pump pathway mediated by Orai1–STIM1–SERCA that is physically localized at SOCE puncta, and a leak pathway through open IP_3Rs at distal sites to activate effectors such as CaCC (Fig. 5). We have previously proposed the term ‘ Ca^{2+} teleporting’ to borrow an analogy from science fiction (Fort, 1931), to suggest rapid transport of Ca^{2+} through the ER lumen given the fact that ER stores are never fully depleted of Ca^{2+} (Courjaret *et al.* 2016*a*). Although a single Ca^{2+} ion is obviously not instantaneously traversing that distance through the ER lumen, the term teleporting nicely reflects the transfer of Ca^{2+} from the SOCE entry sites to CaCCs in a directed fashion to modulate CaCC current. In fact a direct physical interaction has been reported between the IP_3 receptor and Ano1 in neurons (Jin *et al.* 2013; Jin *et al.* 2014); whether a similar interaction exists in the oocyte remains unknown.

In addition to modulating the spatial aspects of Ca^{2+} signals and effector activation, Ca^{2+} tunnelling also modulates the temporal aspects of Ca^{2+} signals by favouring tonic over oscillatory Ca^{2+} signalling (Courjaret *et al.* 2016*a*). When Ca^{2+} stores are relatively full, IP_3 production favours Ca^{2+} oscillations resulting in repetitive transient Ca^{2+} signals. In contrast, when SOCE is fully activated with depleted Ca^{2+} store, Ca^{2+} tunnelling mediates pump–leak balance at the ER membrane that favours tonic sustained Ca^{2+} signalling but inhibiting Ca^{2+} oscillations (Courjaret *et al.* 2016*a*). In this case Ca^{2+}

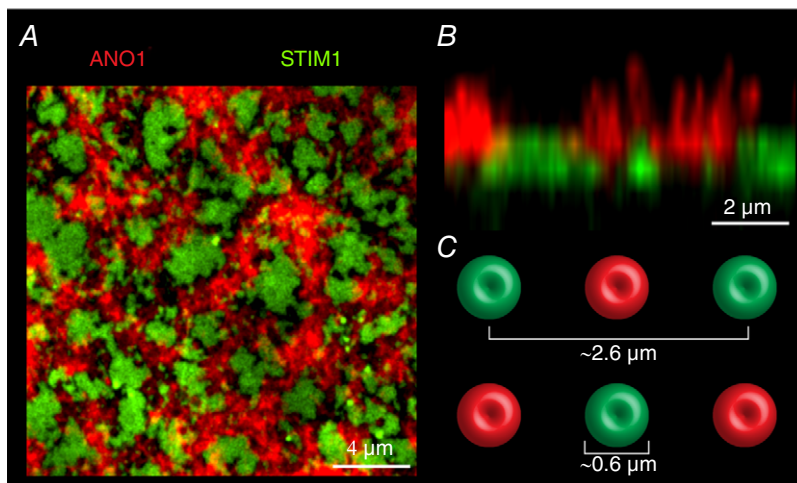

Figure 6. Spatial reorganization of the Ca^{2+} signalling machinery and effectors in response to Ca^{2+} store depletion

A, confocal imaging of *Xenopus* Ano1 tagged with mCherry (red) and of the ER Ca^{2+} sensor STIM1 tagged with green fluorescent protein (green) after store depletion induced by IP_3 injection. The example is an extreme situation where STIM1 forms large fused clusters that exclude the CaCC Ano1. *B*, orthogonal reconstruction of a section of the oocyte in *A*. The microvilli covered by Ano1 are clearly visible as well as the separation between the SOCE domains and the domains painted by Ano1. *C*, dimensions and spatial spread of the SOCE clusters as measured in Courjaret and Machaca (2014).

tunnelling through the ER lumen targets the IP₃ receptor itself and modulates its properties to favour tonic rather than oscillatory signalling. Therefore, Ca²⁺ tunnelling not only modulates the spatial aspects of Ca²⁺ signalling, but also affects the temporal features of Ca²⁺ signals in the same cell. This has significant implications for encoding specific cellular responses downstream of SOCE using Ca²⁺ tunnelling.

Is Ca²⁺ tunnelling active in other cells?

The Ca²⁺ tunnelling system is clearly functional in pancreatic acinar cells and in the frog oocyte. Both of these cell types are highly specialized for a specific function, secretion in the acinar cell and fertilization and support of early development in the oocyte. Therefore, the question arises as to whether this Ca²⁺ signalling mode is ubiquitous or unique to some highly specialized cell types. We currently do not know the answer to this question, but several arguments support the conclusion that this Ca²⁺ signalling modality is widespread. First, SOCE is ubiquitous in non-excitabile cells and present in excitable cells as well. SOCE is physiologically linked to IP₃ receptor activation downstream of agonist stimulation. Therefore, the entire machinery supporting Ca²⁺ tunnelling is present. The spatial remodelling of the Ca²⁺ signalling machinery in response to store depletion outlined in the oocyte system translates and has been described in other cells as well. Furthermore, the IP₃R has been shown to directly link to CaCC, a defined effector for Ca²⁺ tunnelling. Conceptually, the Ca²⁺ tunnelling mechanism is quite attractive as it allows for specific signalling to effectors through the SOCE pathway without inducing a global Ca²⁺ rise in the cytosol and without the need to localize multiple effectors into the physically limited space defined by ER–PM junctions where the SOCE machinery localizes.

In principle, Ca²⁺ tunnelling through the ER should be present in all cell types as it would seem unlikely that SERCA pumps and Ca²⁺ release channels should be exactly co-localized. Therefore Ca²⁺ would always tunnel a bit between Ca²⁺ uptake and release sites. The length of the effective tunnel would vary between cell types depending on their function. The effectiveness and speed of Ca²⁺ tunnelling would depend critically on the concentrations of Ca²⁺ buffers in the ER lumen, their mobility as well as their binding and dissociation rate constants. In addition, it would depend on the degree of depletion of ER Ca²⁺ stores. In the pancreatic acinar cells, it has been shown directly that there are only minor reductions in [Ca²⁺]_{ER} during physiological stimulation (Park *et al.* 2000). In general, it is unlikely that there would be a need for complete depletion of ER Ca²⁺ stores before SOCE is activated. This is indeed the case in the frog oocyte, where IP₃-dependent release of Ca²⁺ from the ER fully activates

SOCE without emptying the stores completely (Courjaret *et al.* 2016a).

In the ER lumen of the pancreatic acinar cells, the movement of Ca²⁺ immediately after localized uncaging of caged Ca²⁺ (following maximal ACh-induced Ca²⁺ release) has been directly monitored. The rate of rise of [Ca²⁺]_{ER} decreases, as expected for a diffusional process, with increasing distance from the uncaging site (Park *et al.* 2000). At a distance of 10 μm from the uncaging site, the peak [Ca²⁺]_{ER} occurs ~2.5 s later than at the uncaging site itself. Complete re-equilibration of [Ca²⁺] in the whole of the ER is attained 6–8 s after the uncaging event (Park *et al.* 2000). These data underestimate the speed of Ca²⁺ movement in the ER lumen under physiological conditions, because of the necessity of first having to evoke maximal release of Ca²⁺ from the ER in order to obtain a clear local increase in [Ca²⁺]_{ER} upon Ca²⁺ uncaging. The free buffer concentration in these experiments (Park *et al.* 2000) would therefore have been higher than under more physiological conditions, where many of the buffers would already have been saturated with Ca²⁺.

One can readily postulate a long list of potential effectors that could be targeted by Ca²⁺ tunnelling with the most obvious being Ca²⁺-regulated ion channels located at the plasma membrane such as CaCCs, Ca²⁺-activated K⁺ channels (Liu *et al.* 1998), other integral membrane proteins such as adenylate cyclases (Halls & Cooper, 2011), and Ca²⁺ sensitive enzymes anchored at the plasma membrane through *A-kinase anchor proteins* such as protein kinase C and phosphatase 2B (Esseltine & Scott, 2013). Ca²⁺ tunnelling effectors are likely to localize in the immediate vicinity of the release site, the IP₃R, and this can include virtually all the downstream effectors of the IP₃R that have been recently reviewed (Prole & Taylor, 2016). In the cytosol, organelles can also be a target for Ca²⁺ tunnelling, including lysosomes, nuclei, vesicles and mitochondria that can all localize next to IP₃Rs. Mitochondria are of particular interest given their intimate interaction with SOCE and the localization of IP₃R to ER–mitochondria junctions (Parekh, 2003).

Currently there are few validated targets of Ca²⁺ tunnelling including CaCCs, Ca²⁺-activated K⁺ channels, secretion in acinar cells, and the IP₃R itself where we have shown that Ca²⁺ tunnelling can modulate IP₃R activity switching it from a mode that favours Ca²⁺ oscillations to one that favours tonic Ca²⁺ signals (Courjaret *et al.* 2016a). There are also hints in the literature of potential additional effectors of Ca²⁺ tunnelling. In a human salivary gland cell line, the direct activation of the Ca²⁺-activated K⁺ channel by SOCE is limited by the fast buffering of Ca²⁺ below the plasma membrane and can be restored when the ER Ca²⁺ pump is inhibited by thapsigargin. When SOCE and IP₃ receptors are simultaneously activated (by stimulating muscarinic receptors with carbachol), Ca²⁺-sensitive K⁺ channels are strongly activated, supporting the idea that

SOCE 'fuels' the IP₃ receptors when the stores are empty to provide an efficient activation of the K⁺ channel (Liu *et al.* 1998).

Conclusion

Herein we focus on findings from two distinctive specialized cell types, the pancreatic acinar cell and the frog oocyte, that led to proposing a novel model of Ca²⁺ signalling that we refer to as Ca²⁺ tunnelling. In pancreatic acinar cells, Ca²⁺ tunnelling allows the transport of Ca²⁺ flowing from the basolateral membrane to support transepithelial fluid transport and secretion of digestive enzymes. The tunnelling of Ca²⁺ through the ER lumen circumvents the slow diffusion of Ca²⁺ through the highly buffered cytosol and importantly delivers Ca²⁺ to effectors in the apical membrane without inducing a global [Ca²⁺]_i rise, which would undoubtedly activate multiple other Ca²⁺-dependent processes. In oocytes, Ca²⁺ tunnelling specifically and efficiently activates CaCCs downstream of SOCE without inducing a global Ca²⁺ rise. This activation occurs spatially in the mid-range broader than the Ca²⁺ microdomain but more contained than a global [Ca²⁺]_i rise. This again eludes the need for Ca²⁺ to diffuse long distances in the highly buffered cytosol and avoids a global [Ca²⁺]_i rise while allowing the activation of a specific effector, CaCC, downstream of SOCE. In addition, Ca²⁺ tunnelling in the oocyte modulates the spatial features of Ca²⁺ signals favouring a tonic signal while inhibiting Ca²⁺ oscillations by acting on the IP₃R itself, in this case as a downstream effector.

Of note is the mechanism underlying Ca²⁺ tunnelling with SOCE forming the Ca²⁺ entry pathway that fuels the whole process. Ca²⁺ entering the cell within the SOCE microdomain is unlikely to diffuse beyond the microdomain due both to the cytoplasmic Ca²⁺ buffering and also to the rapid uptake into the ER lumen through the action of SERCA. This is somewhat reminiscent of the capacitative Ca²⁺ entry model originally proposed by Jim Putney (Putney, 1986), where it was postulated that Ca²⁺ enters the cell directly from the extracellular space into the ER lumen. Although it is now clear that this is not the case, the limited diffusion of Ca²⁺ beyond the SOCE microdomain and the rapid uptake of Ca²⁺ flowing through SOCE into the ER lumen argue that a significant proportion of the signalling downstream of SOCE occurs through Ca²⁺ tunnelling.

Interestingly, the molecular mechanisms underlying Ca²⁺ tunnelling in acinar cells and oocytes are analogous. The machinery mediating Ca²⁺ tunnelling encompasses STIM1 and Orai1 (SOCE), the SERCA pump and the IP₃R. Store depletion stabilizes the STIM1–Orai1 puncta at ER–PM junctions thus providing the source for Ca²⁺ entry from the extracellular space. Ca²⁺ flowing through SOCE channels is taken up by the SERCA pump into

the ER lumen preventing its diffusion out of the SOCE microdomain. In turn ER Ca²⁺ is released through IP₃R thus delivering it to the appropriate effectors (secretion, CaCC, IP₃R) with high efficiency and specificity. The Ca²⁺ tunnelling machinery has been adapted to very different cell physiological needs in the oocyte as compared to the pancreatic acinar cell. In the oocyte it modulates resting membrane potential and the temporal features of Ca²⁺ signals, whereas in the acinar cell it drives enzyme secretion and fluid flow. Given that the molecular machinery underlying Ca²⁺ tunnelling is ubiquitous, it is likely that this pathway is involved in Ca²⁺ signalling in a plethora of other physiological functions. The remarkable functional link between SOCE, SERCA and IP₃R conscripted to allow Ca²⁺ tunnelling results in the delivery of Ca²⁺ to effectors that could easily be missed experimentally and interpreted as signalling downstream of SOCE directly. It is therefore likely that Ca²⁺ tunnelling activates additional cell physiological events that remain to be defined.

References

- Allbritton NL, Meyer T & Stryer L (1992). Range of messenger action of calcium ion and inositol 1,4,5-trisphosphate. *Science* **258**, 1812–1815.
- Alonso MT, Manjarres IM & Garcia-Sancho J (2012). Privileged coupling between Ca²⁺ entry through plasma membrane store-operated Ca²⁺ channels and the endoplasmic reticulum Ca²⁺ pump. *Mol Cell Endocrinol* **353**, 37–44.
- Ashby MC, Camello-Almaraz C, Gerasimenko OV, Petersen OH & Tepikin AV (2003). Long distance communication between muscarinic receptors and Ca²⁺ release channels revealed by carbachol uncaging in cell-attached patch pipette. *J Biol Chem* **278**, 20860–20864.
- Baker PF & Crawford AC (1972). Mobility and transport of magnesium in squid giant axons. *J Physiol* **227**, 855–874.
- Belan PV, Gerasimenko OV, Tepikin AV & Petersen OH (1996). Localization of Ca²⁺ extrusion sites in pancreatic acinar cells. *J Biol Chem* **271**, 7615–7619.
- Berridge MJ (1997). Elementary and global aspects of calcium signalling. *J Physiol* **499**, 291–306.
- Berridge MJ (2016). The inositol trisphosphate/calcium signalling pathway in health and disease. *Physiol Rev* **96**, 1261–1296.
- Berridge MJ, Bootman MD & Roderick HL (2003). Calcium signalling: dynamics, homeostasis and remodelling. *Nat Rev Mol Cell Biol* **4**, 517–529.
- Berridge MJ, Lipp P & Bootman MD (2000). The versatility and universality of calcium signalling. *Nat Rev Mol Cell Biol* **1**, 11–21.
- Bootman MD, Berridge MJ & Roderick HL (2002). Calcium signalling: more messengers, more channels, more complexity. *Curr Biol* **12**, R563–R565.
- Bugrim A, Fontanilla R, Eutenier BB, Keizer J & Nuccitelli R (2003). Sperm initiate a Ca²⁺ wave in frog eggs that is more similar to Ca²⁺ waves initiated by IP₃ than by Ca²⁺. *Biophys J* **84**, 1580–1590.

- Callamaras N & Parker I (2000). Ca²⁺-dependent activation of Cl⁻ currents in *Xenopus* oocytes is modulated by voltage. *Am J Physiol Cell Physiol* **278**, C667–C675.
- Cancela JM, Gerasimenko OV, Gerasimenko JV, Tepikin AV & Petersen OH (2000). Two different but converging messenger pathways to intracellular Ca²⁺ release: the roles of nicotinic acid adenine dinucleotide phosphate, cyclic ADP-ribose and inositol trisphosphate. *EMBO J* **19**, 2549–2557.
- Choi YM, Kim SH, Chung S, Uhm DY & Park MK (2006). Regional interaction of endoplasmic reticulum Ca²⁺ signals between soma and dendrites through rapid luminal Ca²⁺ diffusion. *J Neurosci* **26**, 12127–12136.
- Courjaret R, Dib M & Machaca K (2016a). Store-operated Ca²⁺ entry in oocytes modulate the dynamics of IP₃-dependent Ca²⁺ release from oscillatory to tonic. *J Cell Physiol* **232**, 1095–1103.
- Courjaret R, Hodeify R, Hubrack S, Ibrahim A, Dib M, Daas S & Machaca K (2016b). The Ca²⁺-activated Cl⁻ channel Ano1 controls microvilli length and membrane surface area in the oocyte. *J Cell Sci* **129**, 2548–2558.
- Courjaret R, Hubrack S, Daalis A, Dib M & Machaca K (2013). The *Xenopus* TRPV6 homolog encodes a Mg²⁺-permeant channel that is inhibited by interaction with TRPC1. *J Cell Physiol* **228**, 2386–2398.
- Courjaret R & Machaca K (2014). Mid-range Ca²⁺ signalling mediated by functional coupling between store-operated Ca²⁺ entry and IP₃-dependent Ca²⁺ release. *Nat Commun* **5**, 3916.
- Courjaret R & Machaca K (2016). *Xenopus* oocyte as a model system to study store-operated Ca²⁺ entry (SOCE). *Front Cell Dev Biol* **4**, 66.
- De Stefani D, Raffaello A, Teardo E, Szabo I & Rizzuto R (2011). A forty-kilodalton protein of the inner membrane is the mitochondrial calcium uniporter. *Nature* **476**, 336–340.
- De Stefani D, Rizzuto R & Pozzan T (2016). Enjoy the trip: calcium in the mitochondria back and forth. *Annu Rev Biochem* **85**, 161–192.
- Demuro A & Parker I (2006). Imaging single-channel calcium microdomains. *Cell Calcium* **40**, 413–422.
- Dolmetsch RE, Lewis RS, Goodnow CC & Healy JI (1997). Differential activation of transcription factors induced by Ca²⁺ response amplitude and duration. *Nature* **386**, 855–858.
- Esseltine JL & Scott JD (2013). AKAP signalling complexes: pointing towards the next generation of therapeutic targets? *Trends Pharmacol Sci* **34**, 648–655.
- Feske S (2007). Calcium signalling in lymphocyte activation and disease. *Nat Rev Immunol* **7**, 690–702.
- Fort CH (1931). *Lo!* Cosimo Books, New York.
- Foskett JK, White C, Cheung KH & Mak DO (2007). Inositol trisphosphate receptor Ca²⁺ release channels. *Physiol Rev* **87**, 593–658.
- Gerasimenko JV, Charlesworth RM, Sherwood MW, Ferdek PE, Mikoshiba K, Parrington J, Petersen OH & Gerasimenko OV (2015). Both RyRs and TPCs are required for NAADP-induced intracellular Ca²⁺ release. *Cell Calcium* **58**, 237–245.
- Gerasimenko JV, Gryshchenko O, Ferdek PE, Stapleton E, Hebert TO, Bychkova S, Peng S, Begg M, Gerasimenko OV & Petersen OH (2013). Ca²⁺ release-activated Ca²⁺ channel blockade as a potential tool in antipancreatitis therapy. *Proc Natl Acad Sci USA* **110**, 13186–13191.
- Gerasimenko OV, Gerasimenko JV, Rizzuto RR, Treiman M, Tepikin AV & Petersen OH (2002). The distribution of the endoplasmic reticulum in living pancreatic acinar cells. *Cell Calcium* **32**, 261–268.
- Gerasimenko OV, Gerasimenko JV, Tepikin AV & Petersen OH (1995). ATP-dependent accumulation and inositol trisphosphate- or cyclic ADP-ribose-mediated release of Ca²⁺ from the nuclear envelope. *Cell* **80**, 439–444.
- Goul-Somero M & Jaffe LA (1984). Control of cell fusion at fertilization by membrane potential. In *Cell Fusion: Gene Transfer and Transformation*, ed. Beers RF & Bassett EG, pp. 27–38. Raven Press, New York.
- Halls ML & Cooper DM (2011). Regulation by Ca²⁺-signaling pathways of adenylyl cyclases. *Cold Spring Harb Perspect Biol* **3**, a004143.
- Hofer AM, Fasolato C & Pozzan T (1998). Capacitative Ca²⁺ entry is closely linked to the filling state of internal Ca²⁺ stores: a study using simultaneous measurements of I_{CRAC} and intraluminal [Ca²⁺]. *J Cell Biol* **140**, 325–334.
- Hogan PG (2015). The STIM1-ORAI1 microdomain. *Cell Calcium* **58**, 357–367.
- Hoth M & Penner R (1992). Depletion of intracellular calcium stores activates a calcium current in mast cells. *Nature* **355**, 353–356.
- Hou X, Pedi L, Diver MM & Long SB (2012). Crystal structure of the calcium release-activated calcium channel Orai. *Science* **338**, 1308–1313.
- Jaffe LA, Cross NL & Picheral B (1983). Studies of the voltage-dependent polyspermy block using cross-species fertilization of amphibians. *Dev Biol* **98**, 319–326.
- Jin X, Shah S, Du X, Zhang H & Gamper N (2014). Activation of Ca²⁺-activated Cl⁻ channel ANO1 by localized Ca²⁺ signals. *J Physiol* **594**, 19–30.
- Jin X, Shah S, Liu Y, Zhang H, Lees M, Fu Z, Lippiat JD, Beech DJ, Sivaprasadarao A, Baldwin SA & Gamper N (2013). Activation of the Cl⁻ channel ANO1 by localized calcium signals in nociceptive sensory neurons requires coupling with the IP₃ receptor. *Sci Signal* **6**, ra73.
- Jousset H, Frieden M & Demaurex N (2007). STIM1 knockdown reveals that store-operated Ca²⁺ channels located close to sarco/endoplasmic Ca²⁺ ATPases (SERCA) pumps silently refill the endoplasmic reticulum. *J Biol Chem* **282**, 11456–11464.
- Kar P, Mirams GR, Christian HC & Parekh AB (2016). Control of NFAT isoform activation and NFAT-dependent gene expression through two coincident and spatially segregated intracellular Ca²⁺ signals. *Mol Cell* **64**, 746–759.
- Kasai H & Augustine GJ (1990). Cytosolic Ca²⁺ gradients triggering unidirectional fluid secretion from exocrine pancreas. *Nature* **348**, 735–738.
- Kasai H, Li YX & Miyashita Y (1993). Subcellular distribution of Ca²⁺ release channels underlying Ca²⁺ waves and oscillations in exocrine pancreas. *Cell* **74**, 669–677.

- Kasai H & Petersen OH (1994). Spatial dynamics of second messengers: IP₃ and cAMP as long-range and associative messengers. *Trends Neurosci* **17**, 95–101.
- Kuruma A & Hartzell HC (1998). Dynamics of calcium regulation of Cl currents in *Xenopus* oocytes. *Am J Physiol Cell Physiol* **276**, C161–C175.
- Kuruma A & Hartzell HC (2000). Bimodal control of a Ca²⁺-activated Cl⁻ channel by different Ca²⁺ signals. *J Gen Physiol* **115**, 59–80.
- Lechleiter JD & Clapham DE (1992). Spiral waves and intracellular calcium signalling. *J Physiol Paris* **86**, 123–128.
- Lee MG, Ohana E, Park HW, Yang D & Muallem S (2012). Molecular mechanism of pancreatic and salivary gland fluid and HCO₃ secretion. *Physiol Rev* **92**, 39–74.
- Lin K-H, Taschenberger H & Neher E (2017). Dynamics of volume-averaged intracellular Ca²⁺ in a rat CNS nerve terminal during single and repetitive voltage-clamp depolarizations. *J Physiol* **595**, 3219–3236.
- Liou J, Fivaz M, Inoue T & Meyer T (2007). Live-cell imaging reveals sequential oligomerization and local plasma membrane targeting of stromal interaction molecule 1 after Ca²⁺ store depletion. *Proc Natl Acad Sci USA* **104**, 9301–9306.
- Liou J, Kim ML, Heo WD, Jones JT, Myers JW, Ferrell JE Jr & Meyer T (2005). STIM is a Ca²⁺ sensor essential for Ca²⁺-store-depletion-triggered Ca²⁺ influx. *Curr Biol* **15**, 1235–1241.
- Liu X, Rojas E & Ambudkar IS (1998). Regulation of K_{Ca} current by store-operated Ca²⁺ influx depends on internal Ca²⁺ release in HSG cells. *Am J Physiol Cell Physiol* **275**, C571–C580.
- Luik RM, Wu MM, Buchanan J & Lewis RS (2006). The elementary unit of store-operated Ca²⁺ entry: local activation of CRAC channels by STIM1 at ER-plasma membrane junctions. *J Cell Biol* **174**, 815–825.
- Lur G, Haynes LP, Prior IA, Gerasimenko OV, Feske S, Petersen OH, Burgoyne RD & Tepikin AV (2009). Ribosome-free terminals of rough ER allow formation of STIM1 puncta and segregation of STIM1 from IP₃ receptors. *Curr Biol* **19**, 1648–1653.
- Machaca K (2007). Ca²⁺ signaling differentiation during oocyte maturation. *J Cell Physiol* **213**, 331–340.
- Machaca K & Hartzell HC (1998). Asymmetrical distribution of Ca-activated Cl channels in *Xenopus* oocytes. *Biophys J* **74**, 1286–1295.
- Machaca K & Hartzell HC (1999). Reversible Ca gradients between the sub-plasmalemma and cytosol differentially activate Ca-dependent Cl currents. *J Gen Physiol* **113**, 249–266.
- Machaca K & Haun S (2002). Induction of maturation-promoting factor during *Xenopus* oocyte maturation uncouples Ca²⁺ store depletion from store-operated Ca²⁺ entry. *J Cell Biol* **156**, 75–85.
- Machaca K, Qu Z, Kuruma A, Hartzell HC & McCarty N (2001). The endogenous calcium-activated Cl channel in *Xenopus* oocytes: a physiologically and biophysically rich model system. In *Calcium Activates Chloride Channels*, ed. Fuller CM, pp. 3–39. Academic Press, San Diego.
- Maruyama Y & Petersen OH (1994). Delay in granular fusion evoked by repetitive cytosolic Ca²⁺ spikes in mouse pancreatic acinar cells. *Cell Calcium* **16**, 419–430.
- Maruyama Y, Petersen OH, Flanagan P & Pearson GT (1983). Quantification of Ca²⁺-activated K⁺ channels under hormonal control in pig pancreas acinar cells. *Nature* **305**, 228–232.
- Matthews EK, Petersen OH & Williams JA (1973). Pancreatic acinar cells: acetylcholine-induced membrane depolarization, calcium efflux and amylase release. *J Physiol* **234**, 689–701.
- Mogami H, Gardner J, Gerasimenko OV, Camello P, Petersen OH & Tepikin AV (1999). Calcium binding capacity of the cytosol and endoplasmic reticulum of mouse pancreatic acinar cells. *J Physiol* **518**, 463–467.
- Mogami H, Nakano K, Tepikin AV & Petersen OH (1997). Ca²⁺ flow via tunnels in polarized cells: recharging of apical Ca²⁺ stores by focal Ca²⁺ entry through basal membrane patch. *Cell* **88**, 49–55.
- Morgan AJ & Jacob R (1994). Ionomycin enhances Ca influx by stimulating store-regulated cation entry and not by direct action at the plasma membrane. *Biochem J* **300**, 665–672.
- Neher E (1998). Vesicle pools and Ca²⁺ microdomains: new tools for understanding their roles in neurotransmitter release. *Neuron* **20**, 389–399.
- Nielsen SP & Petersen OH (1972). Transport of calcium in the perfused submandibular gland of the cat. *J Physiol* **223**, 685–697.
- Osipchuk YV, Wakui M, Yule DI, Gallacher DV & Petersen OH (1990). Cytoplasmic Ca²⁺ oscillations evoked by receptor stimulation, G-protein activation, internal application of inositol trisphosphate or Ca²⁺: simultaneous microfluorimetry and Ca²⁺ dependent Cl⁻ current recording in single pancreatic acinar cells. *EMBO J* **9**, 697–704.
- Parekh AB (2003). Store-operated Ca²⁺ entry: dynamic interplay between endoplasmic reticulum, mitochondria and plasma membrane. *J Physiol* **547**, 333–348.
- Parekh AB (2008). Ca²⁺ microdomains near plasma membrane Ca²⁺ channels: impact on cell function. *J Physiol* **586**, 3043–3054.
- Parekh AB (2010). Store-operated CRAC channels: function in health and disease. *Nat Rev Drug Discov* **9**, 399–410.
- Park MK, Ashby MC, Erdemli G, Petersen OH & Tepikin AV (2001a). Perinuclear, perigranular and sub-plasmalemmal mitochondria have distinct functions in the regulation of cellular calcium transport. *EMBO J* **20**, 1863–1874.
- Park MK, Lomax RB, Tepikin AV & Petersen OH (2001b). Local uncaging of caged Ca²⁺ reveals distribution of Ca²⁺-activated Cl⁻ channels in pancreatic acinar cells. *Proc Natl Acad Sci USA* **98**, 10948–10953.
- Park MK, Petersen OH & Tepikin AV (2000). The endoplasmic reticulum as one continuous Ca²⁺ pool: visualization of rapid Ca²⁺ movements and equilibration. *EMBO J* **19**, 5729–5739.
- Petersen CCH, Toescu EC & Petersen OH (1991). Different patterns of receptor-activated cytoplasmic Ca²⁺ oscillations in single pancreatic acinar cells: dependence on receptor type, agonist concentration and intracellular Ca²⁺ buffering. *EMBO J* **10**, 527–533.

- Petersen OH (1992). Stimulus-secretion coupling: cytoplasmic calcium signals and the control of ion channels in exocrine acinar cells. *J Physiol* **448**, 1–51.
- Petersen OH, Findlay I, Iwatsuki N, Singh J, Gallacher DV, Fuller CM, Pearson GT, Dunne MJ & Morris AP (1985). Human pancreatic acinar cells: studies of stimulus-secretion coupling. *Gastroenterology* **89**, 109–117.
- Petersen OH & Maruyama Y (1984). Calcium-activated potassium channels and their role in secretion. *Nature* **307**, 693–696.
- Petersen OH, Petersen CC & Kasai H (1994). Calcium and hormone action. *Annu Rev Physiol* **56**, 297–319.
- Petersen OH & Tepikin AV (2008). Polarized calcium signalling in exocrine gland cells. *Annu Rev Physiol* **70**, 273–299.
- Petersen OH, Tepikin A & Park MK (2001). The endoplasmic reticulum: one continuous or several separate Ca²⁺ stores? *Trends Neurosci* **24**, 271–276.
- Petersen OH & Ueda N (1976). Pancreatic acinar cells: the role of calcium in stimulus-secretion coupling. *J Physiol* **254**, 583–606.
- Petersen OH & Verkhratsky A (2016). Calcium and ATP control multiple vital functions. *Philos Trans R Soc Lond B Biol Sci* **371**, 20150418.
- Prakriya M, Feske S, Gwack Y, Srikanth S, Rao A & Hogan PG (2006). Orai1 is an essential pore subunit of the CRAC channel. *Nature* **443**, 230–233.
- Prakriya M & Lewis RS (2015). Store-operated calcium channels. *Physiol Rev* **95**, 1383–1436.
- Prole DL & Taylor CW (2016). Inositol 1,4,5-trisphosphate receptors and their protein partners as signalling hubs. *J Physiol* **594**, 2849–2866.
- Putney JW (1986). A model for receptor-activated calcium entry. *Cell Calcium* **7**, 1–12.
- Rao A, Luo C & Hogan PG (1997). Transcription factors of the NFAT family: regulation and function. *Annu Rev Immunol* **15**, 707–747.
- Rizzuto R & Pozzan T (2006). Microdomains of intracellular Ca²⁺: molecular determinants and functional consequences. *Physiol Rev* **86**, 369–408.
- Roos J, DiGregorio PJ, Yeromin AV, Ohlsen K, Lioudyno M, Zhang S, Safrina O, Kozak JA, Wagner SL, Cahalan MD, Velicelebi G & Stauderman KA (2005). STIM1, an essential and conserved component of store-operated Ca²⁺ channel function. *J Cell Biol* **169**, 435–445.
- Sampieri A, Zepeda A, Asanov A & Vaca L (2009). Visualizing the store-operated channel complex assembly in real time: identification of SERCA2 as a new member. *Cell Calcium* **45**, 439–446.
- Schroeder BC, Cheng T, Jan YN & Jan LY (2008). Expression cloning of TMEM16A as a calcium-activated chloride channel subunit. *Cell* **134**, 1019–1029.
- Scratcherd T, Hutson D & Case RM (1981). Ionic transport mechanisms underlying fluid secretion by the pancreas. *Philos Trans R Soc Lond B Biol Sci* **296**, 167–178.
- Shuai J & Parker I (2005). Optical single-channel recording by imaging Ca²⁺ flux through individual ion channels: theoretical considerations and limits to resolution. *Cell Calcium* **37**, 283–299.
- Simon SM & Llinas RR (1985). Compartmentalization of the submembrane calcium activity during calcium influx and its significance in transmitter release. *Biophys J* **48**, 485–498.
- Stathopoulos PB, Li GY, Plevin MJ, Ames JB & Ikura M (2006). Stored Ca²⁺ depletion-induced oligomerization of stromal interaction molecule 1 (STIM1) via the EF-SAM region: An initiation mechanism for capacitive Ca²⁺ entry. *J Biol Chem* **281**, 35855–35862.
- Südhof TC (2013). Neurotransmitter release: the last millisecond in the life of a synaptic vesicle. *Neuron* **80**, 675–690.
- Sun XP, Callamaras N, Marchant JS & Parker I (1998). A continuum of InsP₃-mediated elementary Ca²⁺ signalling events in *Xenopus* oocytes. *J Physiol* **509**, 67–80.
- Tepikin AV, Voronina SG, Gallacher DV & Petersen OH (1992). Pulsatile Ca²⁺ extrusion from single pancreatic acinar cells during receptor-activated cytosolic Ca²⁺ spiking. *J Biol Chem* **267**, 14073–14076.
- Thastrup O, Dawson AP, Scharff O, Foder B, Cullen PJ, Drobak BK, Bjerrum PJ, Christensen SB & Hanley MR (1989). Thapsigargin, a novel molecular probe for studying intracellular calcium release and storage. *Agents Actions* **27**, 17–23.
- Thorn P, Lawrie AM, Smith PM, Gallacher DV & Petersen OH (1993). Local and global cytosolic Ca²⁺ oscillations in exocrine cells evoked by agonists and inositol trisphosphate. *Cell* **74**, 661–668.
- Tinel H, Cancela JM, Mogami H, Gerasimenko JV, Gerasimenko OV, Tepikin AV & Petersen OH (1999). Active mitochondria surrounding the pancreatic acinar granule region prevent spreading of inositol trisphosphate-evoked local cytosolic Ca²⁺ signals. *EMBO J* **18**, 4999–5008.
- Toescu EC & Petersen OH (1995). Region-specific activity of the plasma membrane Ca²⁺ pump and delayed activation of Ca²⁺ entry characterize the polarized, agonist-evoked Ca²⁺ signals in exocrine cells. *J Biol Chem* **270**, 8528–8535.
- Vig M, Peinelt C, Beck A, Koomoa DL, Rabah D, Koblan-Huberson M, Kraft S, Turner H, Fleig A, Penner R & Kinet JP (2006). CRACM1 is a plasma membrane protein essential for store-operated Ca²⁺ entry. *Science* **312**, 1220–1223.
- Wakui M, Osipchuk YV & Petersen OH (1990). Receptor-activated cytoplasmic Ca²⁺ spiking mediated by inositol trisphosphate is due to Ca²⁺-induced Ca²⁺ release. *Cell* **63**, 1025–1032.
- Wu MM, Buchanan J, Luik RM & Lewis RS (2006). Ca²⁺ store depletion causes STIM1 to accumulate in ER regions closely associated with the plasma membrane. *J Cell Biol* **174**, 803–813.
- Yamasaki M, Thomas JM, Churchill GC, Garnham C, Lewis AM, Cancela JM, Patel S & Galione A (2005). Role of NAADP and cADPR in the induction and maintenance of agonist-evoked Ca²⁺ spiking in mouse pancreatic acinar cells. *Curr Biol* **15**, 874–878.
- Yang YD, Cho H, Koo JY, Tak MH, Cho Y, Shim WS, Park SP, Lee J, Lee B, Kim BM, Raouf R, Shin YK & Oh U (2008). TMEM16A confers receptor-activated calcium-dependent chloride conductance. *Nature* **455**, 1210–1215.
- Yeromin AV, Zhang SL, Jiang W, Yu Y, Safrina O & Cahalan MD (2006). Molecular identification of the CRAC channel by altered ion selectivity in a mutant of Orai. *Nature* **443**, 226–229.

Zhou W, Chung I, Liu Z, Goldin AL & Dong K (2004). A voltage-gated calcium-selective channel encoded by a sodium channel-like gene. *Neuron* **42**, 101–112.

Additional information

Competing interests

None declared.

Author contributions

All authors have approved the final version of the manuscript and agree to be accountable for all aspects of the work. All persons designated as authors qualify for authorship, and all those who qualify for authorship are listed.

Funding

O.H.P. is a Medical Research Council Professor (G19/22/2).