

Identification of a Novel Coronavirus in Bats

L. L. M. Poon,^{1*} D. K. W. Chu,¹ K. H. Chan,² O. K. Wong,¹ T. M. Ellis,³ Y. H. C. Leung,¹
S. K. P. Lau,¹ P. C. Y. Woo,¹ K. Y. Suen,⁴ K. Y. Yuen,¹ Y. Guan,¹
and J. S. M. Peiris^{1*}

*Department of Microbiology, The University of Hong Kong,¹ Department of Microbiology, Queen Mary Hospital,²
Department of Agriculture, Fisheries, and Conservation,³ and Wildlife Conservation Foundation Limited,⁴
Hong Kong, Special Administrative Region, People's Republic of China*

Received 26 July 2004/Accepted 1 October 2004

Exotic wildlife can act as reservoirs of diseases that are endemic in the area or can be the source of new emerging diseases through interspecies transmission. The recent emergence of severe acute respiratory syndrome-associated coronavirus (SARS-CoV) highlights the importance of virus surveillance in wild animals. Here, we report the identification of a novel bat coronavirus through surveillance of coronaviruses in wildlife. Analyses of the RNA sequence from the ORF1b and S-gene regions indicated that the virus is a group 1 coronavirus. The virus was detected in fecal and respiratory samples from three bat species (*Miniopterus* spp.). In particular, 63% (12 of 19) of fecal samples from *Miniopterus pusillus* were positive for the virus. These findings suggest that this virus might be commonly circulating in *M. pusillus* in Hong Kong.

Coronaviruses are positive-stranded RNA viruses. The viral genomes are between 29 and 32 kb long and are packaged in enveloped virions with corona-like morphology (5). The viral genomes contain five major open reading frames (ORFs) that encode the replicase polyproteins (ORF1a and ORF1ab), the spike (S), envelope (E), and membrane (M) glycoproteins, and the nucleocapsid protein (N) (5, 10). Of these proteins, the replicase polyproteins are directly translated from the viral genome. Translation of ORF1a-encoding sequence can be extended with ORF1b-encoding sequences by a -1 ribosomal frameshift to synthesize ORF1ab polyprotein (5). By contrast, other viral proteins are translated from subgenomic mRNA molecules that are synthesized by a discontinuous RNA synthesis mechanism (14, 22). The ORF1a and ORF1ab polyproteins are nonstructural proteins (6) and are cleaved by papain-like cysteine and 3CL proteinases to generate functional units for viral transcription and replication (26). S, E, M, and N proteins are structural proteins. S is responsible for receptor binding (4). E and M are integral membrane proteins and are the minimal set of proteins for virus assembly (1). N protein is an internal protein, and it binds to viral RNA to form ribonucleoprotein complex (11).

The majority of coronaviruses are disease-causing agents (16). Human coronaviruses are associated with respiratory and gastrointestinal diseases, and animal coronaviruses cause severe respiratory, enteric, neurological, or hepatic disease in their hosts. On the basis of antigenic and genetic analyses, coronaviruses are subdivided into three groups (groups 1 to 3) (5, 7). Group 1 viruses include human coronaviruses NL63 (HCoV-NL63) and 229E (HCoV-229E), canine coronavirus (CCoV), porcine transmissible gastroenteritis virus (TGEV), porcine

epidemic diarrhea virus (PEDV), and feline infectious peritonitis virus (FIPV). Group 2 viruses include human coronavirus OC43 (HCoV-OC43), bovine coronavirus (BCoV), and murine hepatitis virus (MHV). Group 3 viruses are avian viruses, such as avian infectious bronchitis virus (IBV) and turkey coronavirus (TCoV).

Of the coronaviruses identified hitherto, most were isolated from humans, pets, pigs, cattle, or poultry. This bias is presumably because viral investigations are often driven by disease outbreaks in the above populations. By contrast, investigations of wildlife are rare (20, 24), and relatively little is known about the prevalence of coronavirus in wild animal species (3). The identification of severe acute respiratory syndrome-associated coronavirus (SARS-CoV) in civet cats and other wild animals in live animal markets suggests that this novel human pathogen emerged as a result of an interspecies transmission (8). More importantly, these findings highlight the potential human health risk posed by coronaviruses in wild animals. This has prompted us to launch a survey of the prevalence of coronavirus in wild animals in Hong Kong. In particular, we were interested in determining whether wild animals living in this geographical region carry the precursor of SARS-CoV or other unidentified coronaviruses. Here, we report the identification of a novel bat coronavirus (BAT-CoV).

MATERIALS AND METHODS

Sample collection. The animal surveillance program was performed between the summer of 2003 and the summer of 2004. The study was approved and supported by the Department of Agriculture, Fisheries and Conservation, Hong Kong, Special Administrative Region, People's Republic of China. Small mammalian, avian, and reptile species living in natural reservoirs or country parks in Hong Kong were studied. Animals were trapped, and respiratory and fecal swab samples were collected. Before samples were taken, all animals were examined by a veterinary surgeon and confirmed to be free of overt disease. All captured animals were released after samples were taken. Samples were kept in viral transport medium (Earle's balanced salt solution, 0.2% sodium bicarbonate, 0.5% bovine serum albumin, 200 μ g of vancomycin per liter, 18 μ g of amikacin per liter, 160 U of nystatin per liter) at 4°C. In addition, blood samples were

* Corresponding author. Mailing address: Department of Microbiology, University of Hong Kong, Queen Mary Hospital, Pokfulam, Hong Kong, Special Administrative Region, People's Republic of China. Fax: 852 28551241. E-mail: llmpoon@hkucc.hku.hk.

A)

IBV	1	P	A	G	V	E	F	D	T	Y	S	Y	M	M	F	L	A	M	D	A	L	A	P	R	F	E	Y	V	H	K	-	G	Y	S	V	D	L	K	V	Y	T	E	K	O	E	L	F	O	K	Y	F	Y	W	D	O	E	V	H	P	N	C	R	C	S	D	R	C	H	I	H	C	A	N	F	N	I	89											
MHV	1	P	C	G	V	A	V	A	D	S	Y	S	Y	M	M	F	L	M	C	H	A	L	D	S	L	E	N	G	Y	T	R	-	-	-	-	E	P	L	V	O	Y	D	F	T	F	K	L	E	L	F	T	K	Y	F	K	E	S	M	T	Y	H	P	T	C	E	E	D	R	C	H	I	H	C	A	N	F	N	I	85									
229e	1	P	E	M	G	F	P	Y	C	T	S	Y	S	Y	M	M	F	V	M	G	M	N	C	L	A	S	E	C	F	M	K	S	-	I	F	G	D	F	R	T	F	D	L	K	Y	D	F	T	E	H	K	E	V	L	N	K	Y	F	K	Y	W	G	Q	D	Y	H	P	N	C	V	D	C	H	E	M	C	I	L	H	C	S	N	F	N	T	90		
PEDV	1	K	M	G	V	P	I	C	T	S	Y	S	Y	M	M	F	V	M	G	M	N	C	L	A	S	E	C	F	M	K	S	-	I	F	G	D	F	R	T	F	D	L	K	Y	D	F	T	E	H	K	E	V	L	N	K	Y	F	K	Y	W	G	Q	D	Y	H	P	N	C	V	D	C	H	E	M	C	I	L	H	C	S	N	F	N	T	90			
Bat-CoV, 61*	1	L	V	S	G	V	P	I	C	T	S	Y	S	Y	M	M	F	V	M	G	M	N	C	L	A	S	E	C	F	M	K	S	-	I	F	G	D	F	R	T	F	D	L	K	Y	D	F	T	E	H	K	L	K	L	E	D	K	Y	F	K	Y	W	G	Q	D	Y	H	E	D	C	A	D	C	Y	D	E	M	C	I	L	H	C	S	N	F	N	T	90

IBV	90	L	F	S	T	L	F	O	H	S	F	G	N	L	C	R	R	V	E	D	G	V	P	P	T	A	I	C	G	Y	H	S	K	E	L	G	V	I	M	N	O	N	T	M	S	F	S	K	M	G	L	S	O	L	M	O	E	V	G	D	P	A	L	L	V	G	T	S	N	N	L	V	L	R	T	S	C	F	S	V	A	L	T	S	G	I	179
MHV	86	L	F	S	M	V	L	E	K	T	C	F	G	P	L	V	R	Q	L	E	V	D	G	V	P	V	S	I	G	Y	H	K	E	L	G	V	M	M	P	V	D	T	H	R	Y	L	S	L	K	D	L	L	Y	A	A	D	P	A	L	H	V	A	S	A	S	A	L	L	R	T	C	C	F	S	V	A	A	L	T	S	G	V	175				
229e	91	L	E	A	T	T	E	N	T	A	F	G	P	L	C	R	K	V	E	T	D	G	V	V	V	A	T	A	G	Y	H	K	E	L	G	V	M	N	K	O	V	N	T	H	S	T	R	L	T	R	I	T	E	L	L	O	F	V	T	D	P	T	H	V	A	S	S	P	A	L	V	K	R	T	V	C	F	S	V	A	A	L	T	S	G	L	180
PEDV	91	L	E	S	T	L	F	O	H	S	F	G	N	L	C	R	R	V	E	D	G	V	P	P	T	A	I	C	G	Y	H	S	K	E	L	G	V	I	M	N	O	N	T	M	S	F	S	K	M	G	L	S	O	L	M	O	E	V	G	D	P	A	L	L	V	G	T	S	N	N	L	V	L	R	T	S	C	F	S	V	A	L	T	S	G	I	180
Bat-CoV, 61*	91	L	E	A	T	T	E	N	T	A	F	G	P	L	C	R	K	V	E	T	D	G	V	V	V	A	T	A	G	Y	H	K	E	L	G	V	M	N	K	O	V	N	T	H	S	T	R	L	T	R	I	T	E	L	L	O	F	V	T	D	P	T	H	V	A	S	S	P	A	L	V	K	R	T	V	C	F	S	V	A	A	L	T	S	G	L	180

IBV	180	T	R	O	T	V	K	P	G	H	F	N	K	E	F	Y	D	R	L	E	Q	E	F	F	D	E	G	S	E	L	T	L	K	H	F	F	P	O	T	C	N	A	A	I	D	D	Y	Y	R	N	R	P	T	M	F	D	I	C	L	L	F	C	L	E	V	T	S	K	Y	E	C	Y	E	G	G	C	I	P	A	S	O	V	V	269
MHV	176	K	F	O	T	V	K	P	G	H	F	N	K	E	F	Y	D	R	L	E	Q	E	F	F	D	E	G	S	S	V	D	L	K	H	F	F	P	O	T	C	N	A	A	I	D	D	Y	Y	R	N	R	P	T	M	F	D	I	C	L	L	F	V	L	E	V	N	K	Y	E	I	E	G	G	C	I	P	A	T	O	V	V	265		
229e	181	T	R	O	T	V	K	P	G	H	F	N	K	E	F	Y	D	R	L	E	Q	E	F	F	D	E	G	S	E	L	T	L	K	H	F	F	P	O	T	C	N	A	A	I	D	D	Y	Y	R	N	R	P	T	M	F	D	I	C	L	L	F	C	L	E	V	T	S	K	Y	E	C	Y	E	G	G	C	I	P	A	S	O	V	V	270
PEDV	181	T	R	O	T	V	K	P	G	H	F	N	K	E	F	Y	D	R	L	E	Q	E	F	F	D	E	G	S	E	L	T	L	K	H	F	F	P	O	T	C	N	A	A	I	D	D	Y	Y	R	N	R	P	T	M	F	D	I	C	L	L	F	C	L	E	V	T	S	K	Y	E	C	Y	E	G	G	C	I	P	A	S	O	V	V	270
Bat-CoV, 61*	181	T	R	O	T	V	K	P	G	H	F	N	K	E	F	Y	D	R	L	E	Q	E	F	F	D	E	G	S	E	L	T	L	K	H	F	F	P	O	T	C	N	A	A	I	D	D	Y	Y	R	N	R	P	T	M	F	D	I	C	L	L	F	C	L	E	V	T	S	K	Y	E	C	Y	E	G	G	C	I	P	A	S	O	V	V	270

IBV	270	N	N	L	K	S	A	G	Y	E	N	K	F	G	K	A	R	L	Y	E	-	M	S	L	E	P	O	D	L	E	F	I	T	K	N	V	L	P	T	M	O	N	L	K	Y	A	I	S	A	K	N	R	A	R	T	V	A	G	V	S	L	S	T	M	T	N	R	O	F	H	O	K	L	K	S	I	V	N	T	R	N	A	358				
MHV	266	N	N	Y	D	K	S	A	G	Y	E	N	K	F	G	K	A	R	L	Y	E	-	B	A	L	S	F	E	P	O	D	E	Y	A	T	K	R	N	V	L	P	T	M	O	N	L	K	Y	A	I	S	A	K	N	R	A	R	T	V	A	G	V	S	L	S	T	M	T	G	R	M	F	H	O	K	C	L	K	S	I	A	A	T	R	G	V	355
229e	271	T	N	L	N	K	S	A	G	Y	E	N	K	F	G	K	A	R	L	Y	E	-	S	I	S	E	B	O	D	A	I	F	S	L	T	K	R	N	L	P	T	M	O	N	L	K	Y	A	I	S	C	K	E	R	A	R	T	V	G	E	V	S	L	S	T	M	T	T	R	O	F	H	O	K	C	L	K	S	I	V	A	T	R	N	A	360	
PEDV	271	T	N	L	N	K	S	A	G	Y	E	N	K	F	G	K	A	R	L	Y	E	-	S	I	S	E	B	O	D	A	I	F	S	L	T	K	R	N	L	P	T	M	O	N	L	K	Y	A	I	S	C	K	E	R	A	R	T	V	G	E	V	S	L	S	T	M	T	T	R	O	F	H	O	K	L	K	S	I	V	N	T	R	O	A	360		
Bat-CoV, 61*	271	T	N	L	N	K	S	A	G	Y	E	N	K	F	G	K	A	R	L	Y	E	-	B	A	L	S	F	E	P	O	D	A	I	F	S	L	T	K	R	N	L	P	T	M	O	N	L	K	Y	A	I	S	C	K	E	R	A	R	T	V	G	E	V	S	L	S	T	M	T	T	R	O	F	H	O	K	L	K	S	I	V	N	T	R	O	A	360

IBV	359	S	V	V	I	G	T	T	K	F	Y	G	G	W	N	M	L	R	N	L	I	G	V	E	D	E	I	L	M	G	W	D	Y	P	K	C	D	R	A	M	N	L	L	I	A	A	S	L	V	L	A	R	K	H	I	N	C	C	S	R	Y	R	I	N	E	A	C	V	L	E	V	I	G	S	Y	448											
MHV	356	P	V	V	I	G	T	T	K	F	Y	G	G	W	N	M	L	R	N	L	I	G	V	E	D	E	I	L	M	G	W	D	Y	P	K	C	D	R	A	M	N	L	L	I	A	A	S	L	V	L	A	R	K	H	I	N	C	C	S	G	H	T	D	R	F	Y	L	A	N	E	C	A	Q	V	L	E	S	E	I	V	M	C	G	G	Y	Y	445
229e	361	T	V	V	I	G	T	T	K	F	Y	G	G	W	N	M	L	R	N	L	I	G	V	E	D	E	I	L	M	G	W	D	Y	P	K	C	D	R	A	M	N	L	L	I	A	A	S	L	V	L	A	R	K	H	I	N	C	C	S	R	Y	R	I	N	E	A	C	V	L	E	V	V	S	N	G	G	F	Y	450								
PEDV	361	S	V	V	I	G	T																																																																																

TABLE 1. Prevalence of Bat-Cov in animals

Animal type and scientific name	Common name	No. of individual animals	No. of positive respiratory samples	No. of positive fecal samples
Mammals				
<i>Cynopterus sphinx</i>	Short-nosed fruit bat	15	0	0
<i>Hipposideros armiger</i>	Great round-leaf bat	4	0	0
<i>Hipposideros pomona</i>	Bicolored round-leaf bat	3	0	0
<i>Miniopterus magnater</i>	Large bent-winged bat	16	1	2
<i>Miniopterus pusillus</i>	Lesser bent-winged bat	19	5	12
<i>Miniopterus schreibersii</i>	Japanese long-winged bat	4	1	1
<i>Myotis myotis</i>	Large mouse-eared bat	3	0	0
<i>Myotis ricketti</i>	Rickett's big-footed bat	5	0	0
<i>Pipistrellus abramus</i>	Japanese pipistrelle bat	3	0	0
<i>Rhinolophus affinis</i>	Intermediate horseshoe bat	2	0	0
<i>Rhinolophus pusillus</i>	Least horseshoe bat	1	0	0
<i>Rhinolophus rouxi</i>	Rufous horseshoe bat	6	0	0
<i>Canis familiaris</i>	Feral dog	6	0	0
<i>Felis catus</i>	Feral cat	1	0	0
<i>Herpestes javanicus</i>	Javan mongoose	1	0	0
<i>Herpestes urva</i>	Crab-eating mongoose	1	0	0
<i>Hystrix hodgsoni</i>	Chinese porcupine	10	0	0
<i>Macaca mulatta</i>	Rhesus macaque	6	0	0
<i>Melogale moschata</i>	Chinese ferret badger	8	0	0
<i>Muntiacus muntjak</i>	Indian muntjac	4	0	0
<i>Paguma larvata</i>	Himalayan palm civet	21	0	0
<i>Rattus rattus</i>	Black rat	6	0	0
<i>Viverricula indica</i>	Small indian civet	4	0	0
<i>Sus scrofa</i>	Wild boar	9	0	0
Reptiles				
<i>Naja atra</i>	Chinese cobra	1	0	0
<i>Opisthotropis balteata</i>	Banded stream snake	1	0	0
<i>Ptyas korros</i>	Indo-Chinese rat snake	2	0	0
<i>Trachemys scripta elegans</i>	Red-eared slider	1	0	0
<i>Rhabdophis subminiatus helleri</i>	Red-necked keelback	1	0	0
<i>Trimeresurus albolabris</i>	Bamboo snake	1	0	0
<i>Sibynophis chinensis</i>	Chinese mountain snake	1	0	0
<i>Sinonatrix percarinata</i>	Mountain water snake	1	0	0
<i>Elaphe radiata</i>	Copperhead racer	1	0	0
Birds				
<i>Chalcophaps indica</i>	Emerald dove	1	0	0
<i>Garrulax pectoralis</i>	Greater necklaced laughing thrush	1	0	0
<i>Garrulax perspicillatus</i>	Masked laughing thrush	2	0	0
<i>Myophonus caeruleus</i>	Blue whistling thrush	3	0	0
<i>Scolopax rusticola</i>	Eurasian woodcock	1	0	0
<i>Streptopelia chinensis</i>	Spotted dove	3	0	0
<i>Streptopelia orientalis</i>	Oriental turtle dove	3	0	0
<i>Turdus cardis</i>	Japanese thrush	1	0	0
<i>Turdus obscurus</i>	Eyebrowed thrush	1	0	0
<i>Turdus ohortulorum</i>	Grey-backed thrush	1	0	0
<i>Zoothera dauma</i>	Scaly thrush	1	0	0

drawn from captured Himalayan palm civets for neutralization assays for SARS-CoV (8). The neutralization assays were performed as described previously (8).

RNA extraction and reverse transcription. RNA from 140 µl of the sample was extracted by QIAamp virus RNA mini kit (QIAGEN) following the manufacturer's instructions. Extracted RNA was eluted in 50 µl of RNase-free water and stored at -20°C. cDNA was generated as described previously (19). Briefly, 10 µl of eluted RNA samples was reverse transcribed by 200 U of Superscript II reverse transcriptase (Invitrogen) in a 20-µl reaction mixture containing 0.15 µg of random hexamers, 10 mmol of dithiothreitol per liter, and 0.5 mmol of

deoxynucleoside triphosphate per liter. Reaction mixtures were incubated at 42°C for 50 min, followed by a heat inactivation step (72°C for 15 min). Reverse-transcribed products were stored at -20°C.

PCR and sequencing. A pair of consensus primers targeted to the conserved region of coronavirus RNA polymerase (RNA-dependent RNA polymerase [RdRp]) sequences was used to screen the RNA samples (PCR 2 in Table 2). In a typical PCR, 2 µl of cDNA was amplified in a 50-µl reaction mixture containing 0.2 mmol of deoxynucleoside triphosphates per liter, 3 mmol of MgCl₂ per liter, 0.5 µmol of forward primer per liter, 0.5 µmol of reverse primer per liter, and 0.25 U of AmpliTaq Gold (Applied Biosystems). PCR was performed as follows:

FIG. 1. (A) Protein sequence alignment of coronavirus RdRps. The conserved motifs for RdRps are indicated above the sequences. Specimens collected from *M. pusillus* at geographical site 1 (*), *M. pusillus* at geographical site 2 (¶), and *M. schreibersii* (specimen 86) and *M. magnater* (specimens 88 and 96) at site 3 (+) are indicated. 229e, HCoV-229E. (B) Phylogenetic analysis of RNA sequences encoding RdRp (partial sequence).

TABLE 2. Primer sequences positive for Bat-CoV detection

PCR	Target sequence	Primer orientation	Primer sequence (5' to 3')
1	RdRp	Forward	AYAACCAAGATCTTAATGG
		Reverse	TGCTTAGAACCCAAAATCAT
2 ^a	RdRp	Forward	GGTTGGGACTATCCTAAGTGTGA
		Reverse	CCATCATCAGATAGAATCATCATA
3	Helicase-ExoN	Forward	CTCARGGTAGTGARTATGA
		Reverse	AATTGTTCCWCCWGGTGG
4	Spike	Forward	WTATGTTTGYAATGGTAAAY
		Reverse	GTCWTCATCMACWGTRC
5	Spike	Forward	GAYTDDCAGCACTTAATGC
		Reverse	TTGAGCCAYTCAAGRTRYRA
6	Spike	Forward	CAATCTAGGTCTGCTATCG
		Reverse	CTAGAAGACTGTGATTGA

^a Forward and reverse primers (IN-6 and IN-7) were communicated through the World Health Organization's SARS etiology network by colleagues from the Centers for Disease Control and Prevention.

(i) 10 min at 95°C; (ii) 40 cycles, with 1 cycle consisting of 1 min at 95°C, 1 min at 58°C, and 1 min at 72°C. Amplified DNA products were analyzed by agarose gel electrophoresis and DNA sequencing. To avoid possible contamination, RNA extraction, reverse transcription-PCR (RT-PCR), and gel electrophoresis were performed in separate laboratories. In addition, water controls were included in each run of the RT-PCR assay, and no false-positive result was observed in the negative-control reactions.

In subsequent experiments, primers targeted to the RdRp, helicase-ExoN, and S-encoding sequences were used to determine the Bat-CoV sequence (Table 2, PCRs 1 and 3 to 6). PCR conditions of these assays were identical to the PCR assay described above. DNA products with expected sizes were purified by QIAquick PCR purification kit (QIAGEN) and were cloned into DNA vectors (pCR-TOPO; Invitrogen). DNA inserts in purified plasmid were sequenced by BigDye Terminator v3.1 Cycle Sequencing kit (Applied Biosystems). Sequencing products were analyzed by ABI PRISM 3700 DNA analyzer (Applied Biosystems). Both sense and antisense sequences of these PCR products were sequenced at least once.

Data analysis. Deduced viral sequences were analyzed and aligned by BioEdit, version 5.0.9 (<http://www.mbio.ncsu.edu/BioEdit/bioedit.html>). Phylogenetic trees were constructed by the neighbor-joining method, and bootstrap values were determined by 1,000 replicates in MEGA 2.1 (<http://www.megasoftware.net>). Potential glycosylation sites of the S protein were predicted by NetNGlyc 1.0 Server (<http://www.cbs.dtu.dk/services/NetNGlyc/>). Stablecoil 1.0 (<http://www.pence.ca/stablecoil/>) was used to detect the heptad repeat (HR) regions of the S protein. Reference sequences used in the study are FIPV (GenBank accession number AB088222), TGEV (NC002306), HCoV-229E (AF304460), HCoV-NL63 (AY567487), HCoV-OC43 (NC005147), CCoV (AY342160), PEDV (AF353511), IBV (NC005147), MHV (NC001846), and SARS-CoV (NC004718).

Nucleotide sequence accession numbers. The deduced sequences from this study were deposited in GenBank under accession numbers AY864196 to AY864198.

RESULTS

Surveillance. A total of 162 swab samples from 12 bat species and 176 swab samples from 32 other animal species (Table 1) were collected. To identify coronaviruses from these specimens, a pair of consensus primers that can cross-react with a number of coronavirus RdRp sequences were used to screen the field samples (Table 2, PCR 2). Positive PCR amplicons were detected in three different bat species (*Miniopterus* spp. [Table 1]). In particular, 12 of 19 (63%) fecal swab samples from *Miniopterus pusillus* were positive in the screening test. These specimens were collected from three different geographical locations (Fig. 1A).

Identification of a Bat-CoV. To characterize the RdRp sequence deduced from PCR 2 (Table 2), amplicons from each animal were subjected to DNA sequencing. All the sequences generated from *M. pusillus* were highly similar (Fig. 1A). Al-

though there are sequence polymorphisms among these sequences, these sequences form a distinct branch within the clade of group 1 coronavirus RdRp sequences (data not shown). These results suggested that the coronavirus circulating in *M. pusillus* is a novel virus. More interestingly, viral sequences deduced from *Miniopterus magnater* (Fig. 1A, samples 88 and 96) and *Miniopterus schreibersii* (Fig. 1A, sample 86) were also highly similar to those sequences from *M. pusillus* (Fig. 1A), indicating that viruses isolated from these three bat species are the same virus or are of the same lineage.

Attempts to isolate this virus in cell cultures were made. Fecal and respiratory samples were used to infect Madin-Darby canine kidney (MDCK), fetal rhesus kidney (FRhK4) and African green monkey kidney (Vero E6) cells. However, no evidence of virus replication was detected in these cells by cytopathic effect or by RT-PCR.

Characterization of Bat-CoV RdRp, helicase-ExoN, and S sequences. A representative sample from *M. pusillus* (specimen 61 [Fig. 1A]) was selected for further sequence analysis. As mentioned above, our preliminary data indicated that this novel virus is a group 1 coronavirus. On the basis of the conserved regions of group 1 viruses (HCoV-229E, HCoV-NL63, PEDV, TGEV, FIPV, and CCoV), 30 sets of primers were generated for the determination of the viral sequences. Of these PCRs, five additional viral RNA sequences were deduced (Table 2, PCRs 1 and 3 to 6). Alignments of these deduced sequences generated three RNA fragments containing partial sequences for the (i) RdRp gene, (ii) genes C terminal of the helicase gene and N terminal of the hypothetical exonuclease (ExoN) gene, and (iii) S genes (Table 3). The percent sequence identity of each RNA fragment to group 1 to 3 viruses was determined (Table 4). All these RNA sequences shared the highest identity with group 1 coronaviruses (54 to 75%). Phylogenetic analyses of these viral sequences resulted in consensus trees with similar topologies (Fig. 1B, Fig. 3A, and Fig. 4A). In all cases, Bat-CoV clustered with group 1 coronaviruses. In particular, the RdRp and S sequences were most closely related to those of PEDV.

Sequence analysis of the partial sequence of the S gene reveal that this RNA sequence encodes the S2 protein subunit (2, 23). The S protein of coronavirus is known to be heavily glycosylated, and 11 potential N-glycosylation sites were identified (Fig. 2). The deduced sequence contains the HR1 region and part of the sequence of the HR2 region (Fig. 3B and C). These HR regions were separated by an interhelical domain of ~130 amino acid residues (Fig. 2). As with other group 1 coronaviruses, Bat-CoV also has 14 "additional" amino acid residues in both HR regions (Fig. 3C) (2).

The partial RdRp protein sequence of Bat-CoV contains

TABLE 3. Information about Bat-CoV sequences deduced in this study

RNA sequence	Length (nt) ^a	Length of deduced protein sequence (no. of amino acid residues)	Encoding region
1	1,613	537	RdRp
2	591	197	Helicase-ExoN
3	1,448	482	S

^a nt, nucleotides.

TABLE 4. Nucleotide sequence identities of Bat-CoV RNA fragments to other coronaviruses

RNA fragment	% Identity of RNA fragment to:							
	PEDV	TGEV	HCoV-229E	HCoV-NL63	MHV	HCoV-OC43	SARS-CoV	IBV
RdRp	74	70	75	74	60	61	62	63
Helicase-ExoN	71	67	71	72	55	55	55	55
S	58	54	58	60	40	42	41	43

several conserved motifs of RdRps (motifs A to C, G, and F in Fig. 1A) (18, 25). Motif A has two conserved Asp residues separated by four residues and is known for metal ion binding and for recognition of the ribonucleoside triphosphate sugar ring. Motif B contains the highly conserved Ser, Gly, Thr, and Asn residues and is known to be involved in selection of the correct ribonucleoside triphosphate substrate. Motif C contains the highly conserved SDD sequence and is associated with metal ion and 3'-primer terminus binding. Motif F contains several conserved positively charged basic residues and is associated with nucleoside triphosphate binding. This motif could be divided into three submotifs (F1 to F3) (25). Like other coronaviruses, the F motif of Bat-CoV lacks the F2 submotif. The biological functions of the F2 submotif in other viruses are yet to be determined. The G motif had a conserved SXGXP sequence and is known to be involved in positioning of the 5' template strand in other RdRps.

The RNA fragment for the helicase-ExoN junction encodes the last 54 amino acid residues of the RNA helicase and the first 143 amino acid residues of the putative exonuclease (Fig. 4B) (21). The partial sequence for the helicase protein contains the conserved helicase motifs V and VI (12). The partial sequence for the putative ExoN protein contains motif 1 of the DEDD exonuclease superfamily (21). At the junction of these two proteins, a conserved cleavage signal for 3CL proteinase was identified (LQS at positions P2 to P1'), which suggests that the junction may be cleaved by 3CL proteinase expressed by Bat-CoV.

DISCUSSION

Interspecies transmissions of animal viruses to humans are permanent threats to human health. The recent transmissions of SARS-CoV (8), West Nile virus (13), Nipah virus (17), and avian influenza virus (15) from animals to humans have highlighted the importance of surveillance of viruses in wildlife. In order to obtain a better understanding of the prevalence of coronaviruses in this geographical region, we collected more than 300 animal samples from 44 animal species. Using a pair of consensus primers for RdRp of coronaviruses, a novel group 1 virus was identified in three *Miniopterus* spp.

Of 12 bat species examined, the novel Bat-CoV was identified in three different bat species from the same genus. Interestingly, *Myotis chinensis* and *Myotis ricketti*, which frequently cohabit with *M. pusillus* (K. Y. Suen, personal communication), were negative in this investigation. These results demonstrate that this virus has a narrow host range. As the viral sequences in *Miniopterus* spp. are highly similar, our data imply that there are frequent interspecies transmissions between these species. It is not certain which *Miniopterus* species is the natural host of

the virus. However, the majority of *M. pusillus* bats were found to be infected by this virus. In addition, the detection rates of this virus in *M. pusillus* in the summer of 2003 and 2004 were similar (57% in 2003 and 67% in 2004). These observations suggest that *M. pusillus* is likely to be the major reservoir of this virus. As the majority of *M. pusillus* bats in Hong Kong are known to migrate to tropical areas to overwinter (K. Y. Suen, personal communication), we do not know the prevalence of Bat-CoV in this species in winter. Further work on the ecology and behavior of these three bat species in Hong Kong is required to better understand the dynamic of this virus in these animals.

Although all of the infected bats were shown to be healthy upon physical examination, it is not known whether this novel virus is pathogenic in bats. Both fecal and respiratory samples were positive for the virus. However, more than 50% of fecal samples from *M. pusillus* contained this novel virus compared to 26% of respiratory specimens from the same bats, implying that this virus may have a predominantly enteric tropism. Further work is required to elucidate the persistence of the infection, tissue tropism, and possible pathogenicity of this virus.

The deduced Bat-CoV sequences have the typical features of coronaviruses. The virus has the highest sequence identity to group 1 coronaviruses but is clearly distinct from previously known group 1 viruses. Our phylogenetic analyses of these viral sequences also suggest that the virus is a group 1 virus. These findings are further supported by the fact that the S protein of Bat-CoV contains the unique signature of group 1 coronaviruses (i.e., the unique 14 amino acids in HR1 and HR2) (2). Recombination is common in coronaviruses and is thought to contribute to the emergence of new coronaviruses (9). Our limited sequencing results do not allow us to draw any conclusions of the origin of this virus. However, the low sequence homology between Bat-CoV sequences and other coronavirus sequences at least suggest that this novel virus is not a recent recombinant from existing coronaviruses. We are currently attempting to sequence the rest of the viral genome for a full sequence characterization of this virus. However, these efforts are hampered by the inability to culture the virus in vitro.

Apart from the Bat-CoV, we did not identify other coronaviruses in our samples. However, one should note that our results could not reveal a complete picture of the prevalence of coronaviruses in this geographical region. First, our test relies on the detection of viral sequence. Animals with a past coronavirus infection would be negative in our assay. Second, due to the limited sample sizes of each animal species, we might miss the viruses which are circulating in low frequency. Besides, the conserved primers used in this study were based on

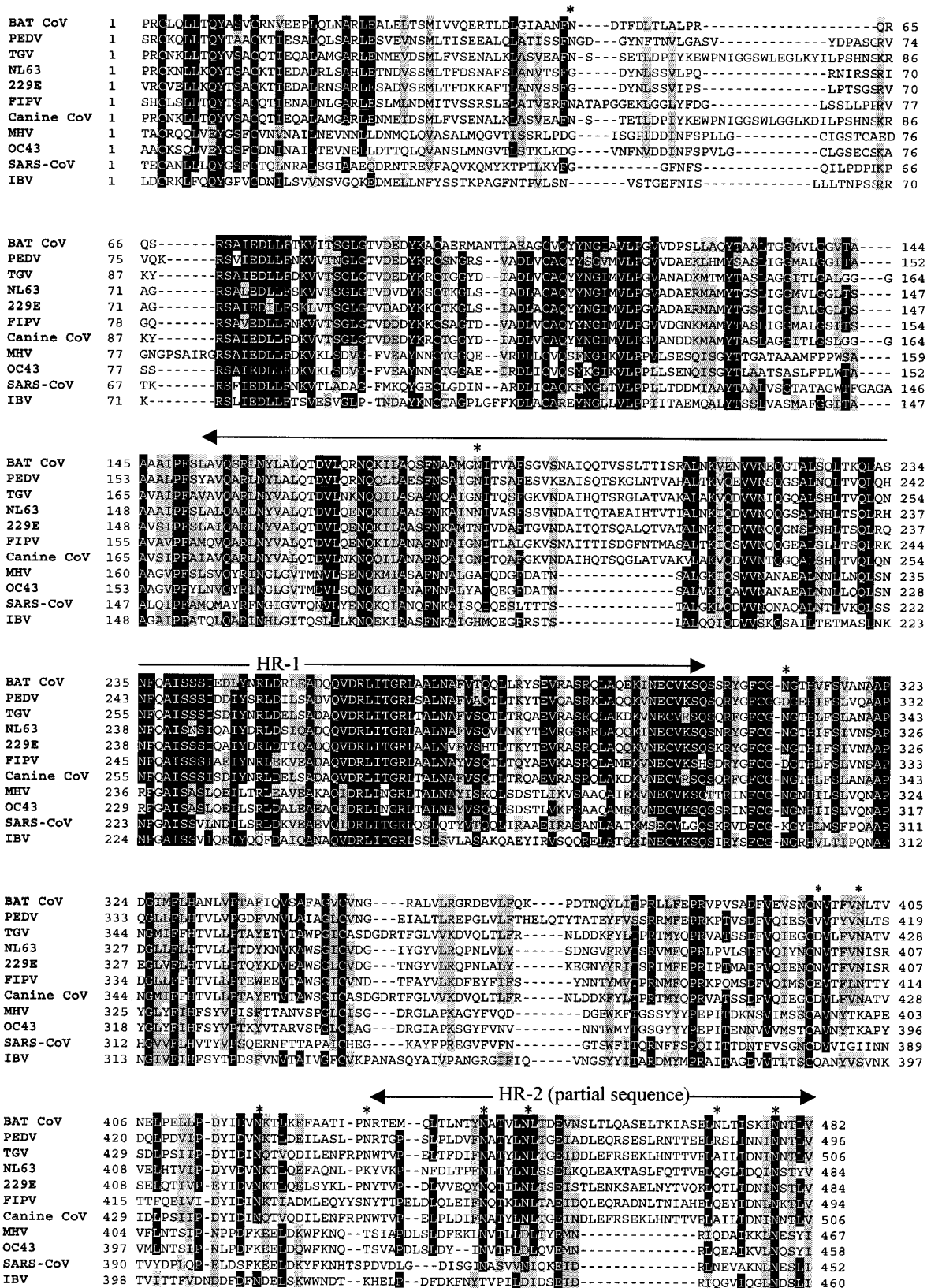
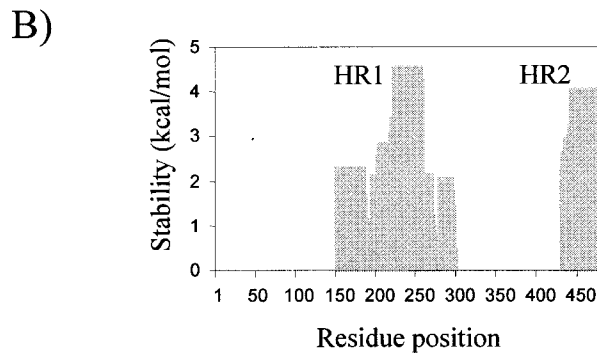
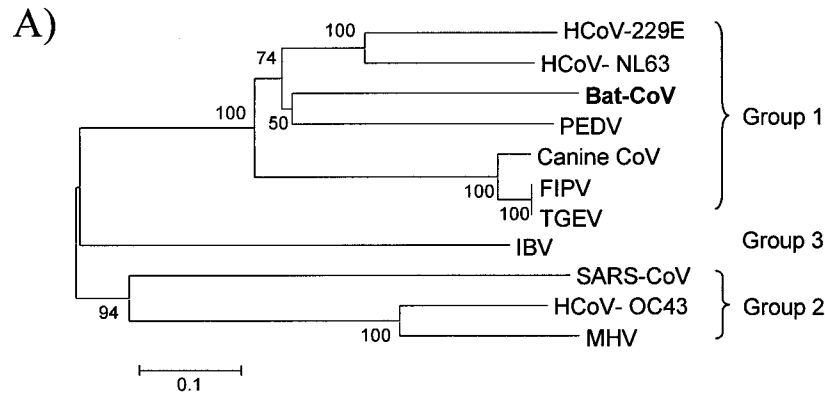

FIG. 2. Protein sequence alignment of coronavirus S proteins (partial sequence). The HR1 and HR2 regions are indicated. The locations of potential N-glycosylation sites in the Bat-CoV sequence are marked by asterisks. TGV, TGEV; NL63, HCoV-N63; 229E, HCoV-229E; OC43, HCoV-OC43.



C) HR1 sequence:

```

d a d a d a d a d a a d a d
LAVQSRNLNYLALQTDVLRNQKILAQSFNAAMGNITVAFSGVSNAIQQTV
a d a d a a d a d a d a d a
SSLTTISRALNKVENNVNEQGTALSQTKQLASNFQAISSSIEDLYNRLD
d a d a d a d a d a d a d
RLEADQQVDRLITGRLAALNAFVTQQLLRYSSEVRASRQLAQEKINECVK
    
```

Partial HR2 sequence:

```

a d a d a d a d a d a d a
NRTEMQLTLNTYNATVNLNLTDEVNSLTLQASELTKIASLNLTIKINNTLV
    
```

FIG. 3. (A) Phylogenetic analysis of RNA sequences for the S gene (partial sequence). (B) Predicted coiled-coil regions in the deduced S-protein sequence. The coiled-coil regions were predicted by Stablecoil 1.0 with a 35-residue window width. The HR1 and HR2 regions are indicated. (C) HR1 and HR2 in the S protein of Bat-CoV. The a and d positions of the strongest predicted coiled-coil heptad repeats are indicated. The 14-amino-acid residue insertions that are unique in group 1 viruses are underlined.

available coronavirus sequences, and these primers might not be able to detect coronaviruses that are genetically more divergent from previously known coronaviruses.

We previously reported that SARS-CoV could be isolated from Himalayan palm civets (8). It should be noted that the SARS-CoV-positive animals in our previous study were obtained from wild animal markets and not captured in the wild. None of the civets examined in our current study ($n = 21$) was positive for SARS-CoV by both serological and molecular tests. The results from our present study do not exclude the possibility that the civet is the natural host of SARS-CoV, but our results at least indicate that SARS-CoV is not broadly

circulating in wild civets. Further investigations are required to elucidate the natural reservoir of SARS-CoV, especially in mainland China.

In conclusion, we reported that a novel coronavirus was identified from bats. The virus has the highest homology to group 1 coronaviruses. Bats are the reservoir for lyssaviruses and henipaviruses and are responsible for emerging diseases in humans. It is not known whether this virus would cause zoonotic disease in humans or other animals. Further investigations are needed to understand the ecology and pathogenicity of this virus. In addition, this study also highlighted our poor understanding of viruses in wild animals. Given the

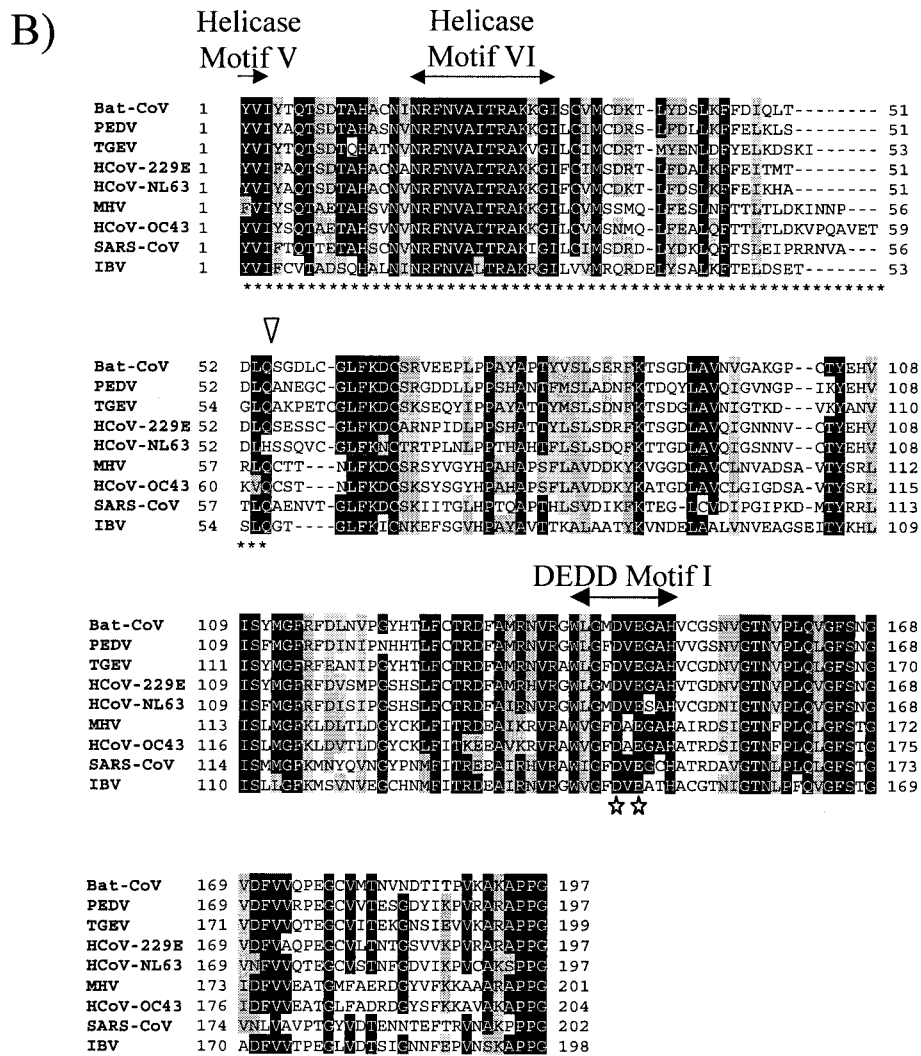
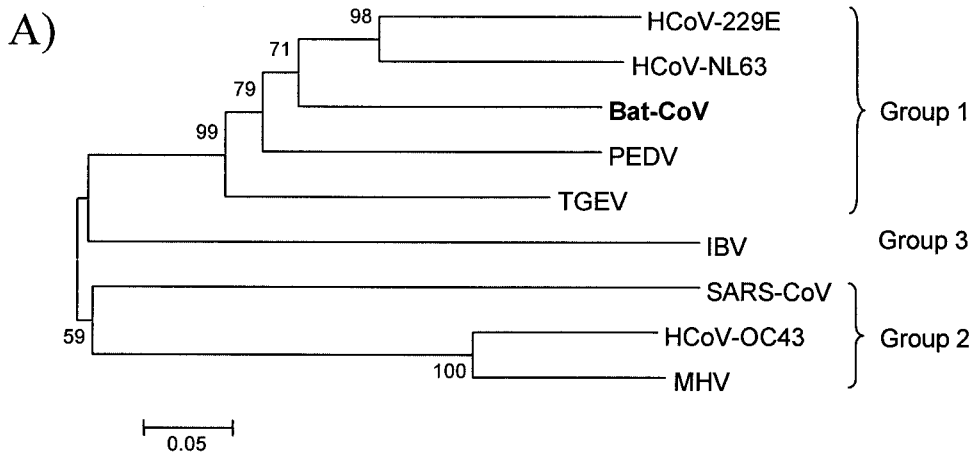

FIG. 4. (A) Phylogenetic analysis of RNA sequences coding for helicase-ExoN (partial sequence). (B) Protein sequence alignment of coronavirus helicase-ExoN. The conserved motifs for helicases and the first motif for ExoN (DEDD motif I) are indicated. The invariant acidic residues in DEDD motif I are labeled with white stars below the sequences. The inverted open triangle above the sequences marks the predicted 3CL proteinase cleavage site.

catastrophic consequences of SARS, further surveillance work on viruses in wildlife should be encouraged.

ACKNOWLEDGMENTS

This work was supported in part by a Public Health research grant from the National Institute of Allergy and Infectious Diseases of the United States (AI95357) and by grants from The Research Grant Council of Hong Kong (HKU 7356/03 M to L.L.M.P. and HKU 7542/03 M to J.S.M.P.).

We thank K. S. Cheung and C. T. Shek from the Department of Agriculture, Fisheries, and Conservation of Hong Kong for assistance.

REFERENCES

- Bos, E. C., W. Luytjes, H. V. van der Meulen, H. K. Koerten, and W. J. Spaan. 1996. The production of recombinant infectious DI-particles of a murine coronavirus in the absence of helper virus. *Virology* **218**:52–60.
- Bosch, B. J., R. van der Zee, C. A. de Haan, and P. J. Rottier. 2003. The coronavirus spike protein is a class I virus fusion protein: structural and functional characterization of the fusion core complex. *J. Virol.* **77**:8801–8811.
- Breithaupt, H. 2003. Fierce creatures. Zoonoses, diseases that jump from animals to humans, are a growing health problem around the world. Understanding their causes and their effects on humans have therefore become an important topic for global public health. *EMBO Rep.* **4**:921–924.
- Gallagher, T. M., and M. J. Buchmeier. 2001. Coronavirus spike proteins in viral entry and pathogenesis. *Virology* **279**:371–374.
- Gonzalez, J. M., P. Gomez-Puertas, D. Cavanagh, A. E. Gorbalenya, and L. Enjuanes. 2003. A comparative sequence analysis to revise the current taxonomy of the family *Coronaviridae*. *Arch. Virol.* **148**:2207–2235.
- Gorbalenya, A. E., E. V. Koonin, A. P. Donchenko, and V. M. Blinov. 1989. Coronavirus genome: prediction of putative functional domains in the non-structural polyprotein by comparative amino acid sequence analysis. *Nucleic Acids Res.* **17**:4847–4861.
- Gorbalenya, A. E., E. J. Snijder, and W. J. Spaan. 2004. Severe acute respiratory syndrome coronavirus phylogeny: toward consensus. *J. Virol.* **78**:7863–7866.
- Guan, Y., B. J. Zheng, Y. Q. He, X. L. Liu, Z. X. Zhuang, C. L. Cheung, S. W. Luo, P. H. Li, L. J. Zhang, Y. J. Guan, K. M. Butt, K. L. Wong, K. W. Chan, W. Lim, K. F. Shortridge, K. Y. Yuen, J. S. Peiris, and L. L. Poon. 2003. Isolation and characterization of viruses related to the SARS coronavirus from animals in southern China. *Science* **302**:276–278.
- Herrewegh, A. A., I. Smeenk, M. C. Horzinek, P. J. Rottier, and R. J. de Groot. 1998. Feline coronavirus type II strains 79–1683 and 79–1146 originate from a double recombination between feline coronavirus type I and canine coronavirus. *J. Virol.* **72**:4508–4514.
- Holmes, K. V., and L. Enjuanes. 2003. The SARS coronavirus: a postgenomic era. *Science* **300**:1377–1378.
- Huang, Q., L. Yu, A. M. Petros, A. Gunasekera, Z. Liu, N. Xu, P. Hajduk, J. Mack, S. W. Fesik, and E. T. Olejniczak. 2004. Structure of the N-terminal RNA-binding domain of the SARS CoV nucleocapsid protein. *Biochemistry* **43**:6059–6063.
- Ivanov, K. A., V. Thiel, J. C. Dobbe, Y. van der Meer, E. J. Snijder, and J. Ziebuhr. 2004. Multiple enzymatic activities associated with severe acute respiratory syndrome coronavirus helicase. *J. Virol.* **78**:5619–5632.
- Kulasekera, V. L., L. Kramer, R. S. Nasci, F. Mostashari, B. Cherry, S. C. Trock, C. Glaser, and J. R. Miller. 2001. West Nile virus infection in mosquitoes, birds, horses, and humans, Staten Island, New York, 2000. *Emerg. Infect. Dis.* **7**:722–725.
- Lai, M. M., R. S. Baric, P. R. Brayton, and S. A. Stohman. 1984. Characterization of leader RNA sequences on the virion and mRNAs of mouse hepatitis virus, a cytoplasmic RNA virus. *Proc. Natl. Acad. Sci. USA* **81**:3626–3630.
- Li, K. S., Y. Guan, J. Wang, G. J. Smith, K. M. Xu, L. Duan, A. P. Rahardjo, P. Puthavathana, C. Buranathai, T. D. Nguyen, A. T. Estoe pangestie, A. Chaisingh, P. Auewarakul, H. T. Long, N. T. Hanh, R. J. Webby, L. L. Poon, H. Chen, K. F. Shortridge, K. Y. Yuen, R. G. Webster, and J. S. Peiris. 2004. Genesis of a highly pathogenic and potentially pandemic H5N1 influenza virus in eastern Asia. *Nature* **430**:209–213.
- Navas-Martín, S., and S. R. Weiss. 2003. SARS: lessons learned from other coronaviruses. *Viral Immunol.* **16**:461–474.
- Paton, N. I., Y. S. Leo, S. R. Zaki, A. P. Auchus, K. E. Lee, A. E. Ling, S. K. Chew, B. Ang, P. E. Rollin, T. Umapathi, I. Sng, C. C. Lee, E. Lim, and T. G. Ksiazek. 1999. Outbreak of Nipah-virus infection among abattoir workers in Singapore. *Lancet* **354**:1253–1256.
- Poch, O., I. Sauvaget, M. Delarue, and N. Tordo. 1989. Identification of four conserved motifs among the RNA-dependent polymerase encoding elements. *EMBO J.* **8**:3867–3874.
- Poon, L. L., O. K. Wong, K. H. Chan, W. Luk, K. Y. Yuen, J. S. Peiris, and Y. Guan. 2003. Rapid diagnosis of a coronavirus associated with severe acute respiratory syndrome (SARS). *Clin. Chem.* **49**:953–955.
- Riley, S. P., J. Foley, and B. Chomel. 2004. Exposure to feline and canine pathogens in bobcats and gray foxes in urban and rural zones of a national park in California. *J. Wildl. Dis.* **40**:11–22.
- Snijder, E. J., P. J. Bredenbeek, J. C. Dobbe, V. Thiel, J. Ziebuhr, L. L. Poon, Y. Guan, M. Rozanov, W. J. Spaan, and A. E. Gorbalenya. 2003. Unique and conserved features of genome and proteome of SARS-coronavirus, an early split-off from the coronavirus group 2 lineage. *J. Mol. Biol.* **331**:991–1004.
- Spaan, W., H. Delius, M. Skinner, J. Armstrong, P. Rottier, S. Smeekens, B. A. van der Zeijst, and S. G. Siddell. 1983. Coronavirus mRNA synthesis involves fusion of non-contiguous sequences. *EMBO J.* **2**:1839–1844.
- Tripet, B., M. W. Howard, M. Jobling, R. K. Holmes, K. V. Holmes, and R. S. Hodges. 2004. Structural characterization of the SARS-coronavirus spike S fusion protein core. *J. Biol. Chem.* **279**:20836–20849.
- Tsunemitsu, H., Z. R. el-Kanawati, D. R. Smith, H. H. Reed, and L. J. Saif. 1995. Isolation of coronaviruses antigenically indistinguishable from bovine coronavirus from wild ruminants with diarrhea. *J. Clin. Microbiol.* **33**:3264–3269.
- Xu, X., Y. Liu, S. Weiss, E. Arnold, S. G. Sarafianos, and J. Ding. 2003. Molecular model of SARS coronavirus polymerase: implications for biochemical functions and drug design. *Nucleic Acids Res.* **31**:7117–7130.
- Ziebuhr, J., E. J. Snijder, and A. E. Gorbalenya. 2000. Virus-encoded proteinases and proteolytic processing in the *Nidovirales*. *J. Gen. Virol.* **81**:853–879.