

Identification of human antibody fragment clones specific for tetanus toxoid in a bacteriophage λ immunoexpression library

(immunoglobulin genes/filter hybridization screening/expression in *Escherichia coli*/ immunotherapy/infectious disease)

REBECCA L. MULLINAX*, ELEANORE A. GROSS*, JEFF R. AMBERG*, BEVERLY N. HAY†, HOLLY H. HOGREFE*, MARJORIE M. KUBITZ*, ALAN GREENER*, MICHELLE ALTING-MEES*, DANIEL ARDOUREL*, JAY M. SHORT*, JOSEPH A. SORGE*, AND BOB SHOPES†‡

*Stratagene, 11099 North Torrey Pines Road, Suite 200, La Jolla, CA 92037; and †Stratacyte, 11099 North Torrey Pines Road, Suite 400, La Jolla, CA 92037

Communicated by Michael Wigler, August 2, 1990 (received for review May 8, 1990)

ABSTRACT We have applied a molecular biology approach to the identification of human monoclonal antibodies. Human peripheral blood lymphocyte mRNA was converted to cDNA and a select subset was amplified by the polymerase chain reaction. These products, containing coding sequences for numerous immunoglobulin heavy- and κ light-chain variable and constant region domains, were inserted into modified bacteriophage λ expression vectors and introduced into *Escherichia coli* by infection to yield a combinatorial immunoexpression library. Clones with binding activity to tetanus toxoid were identified by filter hybridization with radiolabeled antigen and appeared at a frequency of 0.2% in the library. These human antigen binding fragments, consisting of a heavy-chain fragment covalently linked to a light chain, displayed high affinity of binding to tetanus toxoid with equilibrium constants in the nanomolar range but did not cross-react with other proteins tested. We estimate that this human immunoexpression library contains 20,000 clones with high affinity and specificity to our chosen antigen.

Human antibodies are desired for immunotherapeutic applications to obviate the deleterious "human anti-mouse antibody" response (1). Production of human monoclonal antibodies has been accomplished previously by tissue culture manipulation, either by cell fusion with an immortal partner and/or by transformation with a virus. These techniques have persistent problems, such as low clonal frequency, low antibody production, and cell-line instability (2–4).

Genetic engineering methods have been used to modify existing murine monoclonal antibodies by conversion of murine primary sequences to human. Chimeric antibodies, consisting of murine variable (V) domains and human constant domains, have been constructed by shuttling genomic exons (5–14). These may be less immunogenic than their murine counterparts but one-third of their composition is of murine origin; therefore their therapeutic effectiveness may be limited. The chimeric concept has been taken a step further to the "humanization" of murine V domains by grafting human framework regions with murine complementarity determining regions (15–19). This process may lead to lower immunogenicity but has also led to reduced affinity for antigen with possible concomitant changes in specificity.

The polymerase chain reaction (PCR) has been used extensively with primers specific for immunoglobulin superfamily genes (20–26). Methods to directly express murine antibody fragments in *Escherichia coli* from PCR amplified cDNA have recently been developed. A murine heavy (H)-chain library had been created by using Lambda ZAP II as a

cloning vehicle but specificity of binding was not tested (24). Murine V_H domains that bound lysozyme with reasonable affinity and specificity have been expressed in a pUC19 plasmid system (25). In addition, hapten binding clones were identified from a murine combinatorial library in which H chain fragment was coexpressed with light (L) chain (26). In each case, mice were immunized and murine splenic B cells were used as the source of mRNA. We have now developed a method to identify human antibody fragments that bind a specified antigen by using mRNA derived from human peripheral blood lymphocytes.

MATERIALS AND METHODS

The methodology used to create and screen a human combinatorial immunoexpression library is detailed in Fig. 1.

Source of mRNA. As an antigen, we chose tetanus toxoid (TT), a well characterized and highly immunogenic protein (27) that is routinely used as a vaccine to elicit neutralizing antibody. Volunteer donors, who had been previously immunized against tetanus but had not received booster injections within the past year, received injections on 2 consecutive days of 0.5 ml of alum-adsorbed TT (40 μ g/ml) (Connaught Laboratories). A transient increase in circulating anti-TT IgG-producing B cells was reported to occur after the injection (28), which we quantified with an ELISPOT (enzyme-linked immunospot) assay (29). Harvesting 6 days after injection allowed the use of peripheral blood lymphocytes as an enriched source of B-cell mRNA for anti-TT IgG. Lymphocytes were isolated from whole blood by using Histopaque (Sigma). Total RNA was then purified from these cells (RNA isolation kit; Stratagene).

PCR Amplification. Isolated RNA was converted to cDNA with a first-strand synthesis kit (Stratagene) and by using an oligo(dT) primer for the L chain and a specific primer for the H chain. PCR amplification of the immunoglobulin H- and L-chain sequences were done separately with sets of primer pairs. Upstream primers were designed to hybridize to partially conserved sequences in the leader and/or framework regions of V_H or V_L(κ) and downstream primers were designed to hybridize to constant domain sequences (Fig. 2). These primers preserved full-length L chain [L(κ)]. However, the H-chain primer was designed such that the gene is terminated just 3' of the first cysteine codon in the hinge exon. The resulting gene product (H fragment) is intended to correspond to a Fd of IgG1 isotype and conserves the H–L disulfide bond. PCRs were carried out with *Thermus aquaticus*

The publication costs of this article were defrayed in part by page charge payment. This article must therefore be hereby marked "advertisement" in accordance with 18 U.S.C. §1734 solely to indicate this fact.

Abbreviations: H, heavy; L, light; PCR, polymerase chain reaction; V_H, H-chain variable domain; V_L, L-chain variable domain; TT, tetanus toxoid; HRP, horseradish peroxidase; DT, diphtheria toxoid; KLH, keyhole limpet hemocyanin; trpR, tryptophan repressor.
‡To whom reprint requests should be addressed.

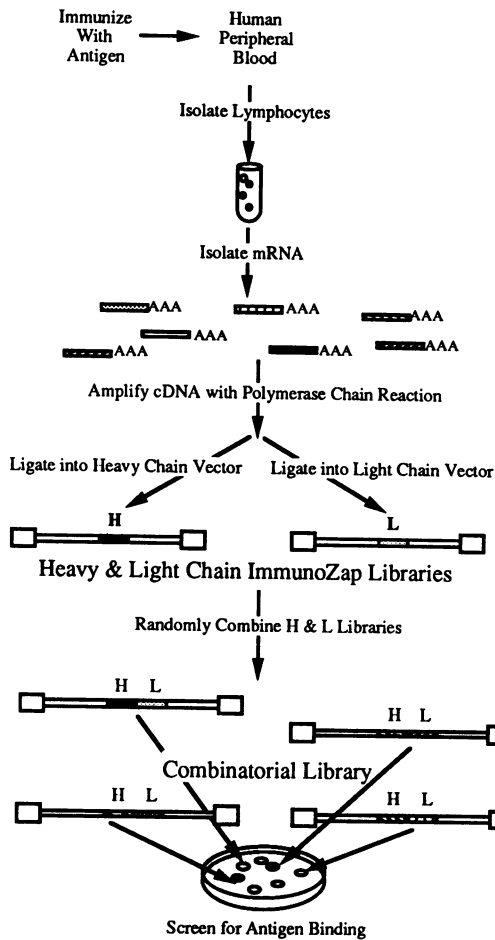

FIG. 1. Schematic outline of the construction of the immunoeexpression library.

icus DNA polymerase (*Taq* polymerase) (Perkin-Elmer/Cetus).

DNA Manipulation and Analysis. Enzymatic digestion, ligation, packaging, and sequencing of DNA and analysis by agarose or acrylamide gels were done according to suppliers' recommendations. All enzymes were obtained from Stratagene except for Sequenase (United States Biochemical).

Construction of Immunoeexpression Libraries. The PCR amplified L-chain DNA fragments were digested with *Sac* I and *Xba* I and ligated into a modified Lambda Zap II vector (ImmunoZAP L; Stratagene, La Jolla, CA). Similarly, the amplified H-chain DNA was digested with *Spe* I and *Xho* I and ligated into a different modified Lambda Zap II vector (ImmunoZAP H; Stratagene). Each vector contains a *pelB* leader sequence, which has been previously used for immunoglobulin chain expression in *E. coli* (24-26, 31), a ribosome binding site, and stop codons. In addition, the H-chain vector contains a sequence for a C-terminal decapeptide tag. The ligated recombinant phage DNA was incorporated into bacteriophage with *in vitro* packaging extract (Gigapack II Gold; Stratagene). Infection of *E. coli* (strain XL-1 Blue; Stratagene) with bacteriophage was performed with excess bacteria to limit the possibility of coinfection. Moreover, if coinfection does occur, then replication of the late-arriving phage is repressed via *cl*. This ensures that in an immunoeexpression library a plaque corresponds to, at most, a single antibody fragment.

Recently, binding of V_H alone to lysozyme has been shown (25) but previous reports indicate that isolated single immunoglobulin chains have little or no affinity for antigen (32, 33). We chose to coexpress the H fragment and L chain so that a

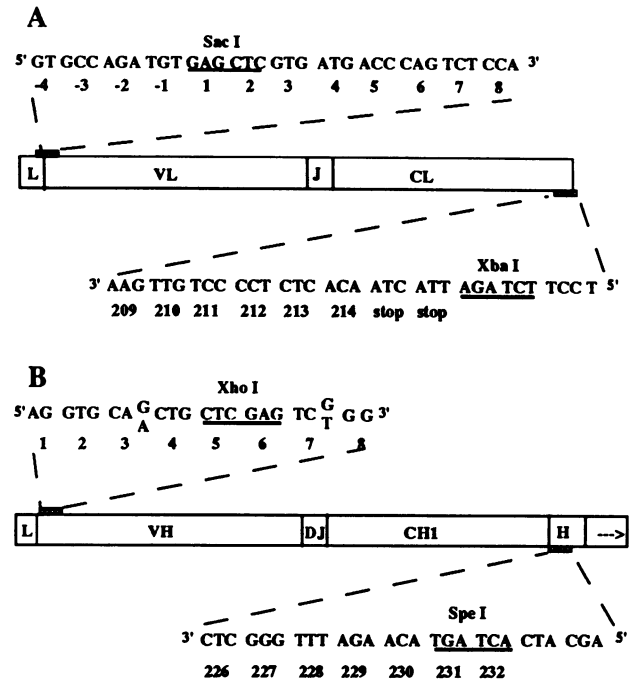

FIG. 2. (A) Human L(κ)-chain primer sequences. Open bar, coding portion of cDNA for a L(κ) chain. *Sac* I and *Xba* I restriction sites are introduced by the upstream sense primer and the downstream antisense primer, respectively. Numbers below the primers indicate residue number in the processed L(κ) chain (30). Note that the antisense primer is written 3' to 5'. (B) Human H-chain primer sequences. *Xho* I and *Spe* I sites are introduced by the upstream sense primer and the downstream antisense primer, respectively. In addition to the four related upstream sense primers shown, the primer 5'-AGGTCCAGCTGCTCGAGTCTGG-3' was used for V_H . In proper frame, the 3' end of the H-chain PCR products as dictated by these primers will code for Pro-Lys-Ser-Cys-Thr-Ser, where the first four amino acids are derived from the human IgG hinge domain and the last two are from the *Spe* I restriction site. Note that when cloned into the ImmunoZap H vector this sequence will be followed by a decapeptide tag and stop codons (see Fig. 3). J, joining; C, constant; D, diversity.

Fab-like species would be the result. To construct a library for coexpression, the right arm of H-chain library phage DNA was digested with *Hind*III, preserving the left arm of ImmunoZAP H with H inserts. Similarly, the left arm of L-chain library phage DNA was digested with *Mlu* I, yielding a right arm of ImmunoZAP with L(κ) inserts. Both products were then digested with *Eco*RI and ligated to create a combinatorial library (Fig. 3). The resulting DNA was packaged and used to infect *E. coli* as described above.

Screening of Immunoeexpression Libraries. To screen for expression of H fragment or L chain, *E. coli* were infected to yield ≈ 200 plaques per plate. Replica filter lifts of the plaques on an agar plate were produced by overlaying a nitrocellulose filter that had been soaked in 10 mM isopropyl β -D-thiogalactopyranoside on each plate with transfer for 15 hr at 23°C. For quantification of H fragment expression, the filters were screened as described (26). For L(κ)-chain expression, the filters were screened similarly, but rabbit anti-human κ (Cappel Laboratories) was used as the primary antibody.

In the primary antigen binding screen, *E. coli* were infected to yield ≈ 1200 plaques per plate. Replica filters were incubated with 0.2 nM ¹²⁵I-labeled TT (¹²⁵I-TT) and washed. Positive plaques were identified by autoradiography and isolated. These phage clones were further analyzed in a secondary screen carried out at a lower density. The frequency of positive clones in the library was equivalent to (number of positive clones)/(number of plaques screened) \times

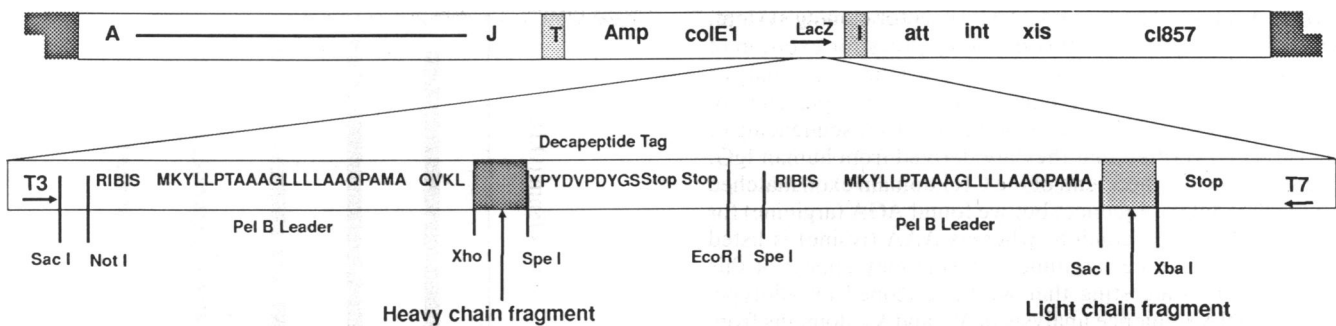

FIG. 3. The ImmunoZAP H/L vector containing random combinations of H and L-chain inserts. The pelB leader, decapeptide tag, and ribosome binding site (RIBIS) are indicated. Note that the mRNA will be dicistronic. For details on the phage arms see ref. 34.

(fraction of plaques expressing H and L)]. Concentrated nonadsorbed TT (Connaught Laboratories) was iodinated with Na^{125}I (ICN) by the Chloramine-T method.

Protein Analysis. After *in vivo* excision of the phagemid from the λ phage in *E. coli* (34), expression was driven by induction with isopropyl β -D-thiogalactopyranoside. Bacterial supernatant was passed over a 1-ml protein G column (Pharmacia), which has binding sites for Fab as well as Fc (35). After washing with buffer, human antibody Fab fragments were eluted at pH 2.5. Fractions were analyzed by SDS/PAGE (Novex, Encinitas, CA) and the bands were visualized with silver stain (Stratagene). Positive identification of the composition of the human antibody fragments was done by Western blot analysis with anti-human H+L (Cappel Laboratories) and anti-human L(κ) (Calbiochem) antibodies. Concentration of human antibody fragment was quantified by ELISA. The capture antibody was goat anti-human Fab (IgG) (ICN) and the detection reagent was goat anti-human immunoglobulin coupled to alkaline phosphatase (Cappel Laboratories). A proteolytically generated human Fab (Pel-Freez Biologicals) was used as a standard in SDS/PAGE and ELISA.

Competitive Inhibition. A plaque was generated by directly spotting 1 μl of a phage stock (10^6 plaque-forming units per ml) of a positive clone onto a lawn of *E. coli* followed by several hours of lytic growth. Replica plaque lifts were made as in the library screen. Control antibodies, including a hybridoma-derived murine anti-TT antibody (Boehringer Mannheim), were spotted directly onto the filter strip. Competitive inhibition experiments were done by incubating the filter strips with various concentrations of unlabeled TT in the presence of ^{125}I -TT. After washing, the filters were autoradiographed.

Specificity Determination. Reactivity of the TT binding clones was determined by ELISA. Protein, at 5 $\mu\text{g}/\text{ml}$ in 0.1 M borate buffer, was adsorbed overnight in a 96-well plate. Either a positive control antibody or *E. coli* supernatant containing human Fab was added and incubated for 1 hr. This was followed by a secondary antibody coupled to alkaline phosphatase and developed with *p*-nitrophenyl phosphate (10 mg/ml) (Sigma) and absorbance at 405 nm. Between each addition, the plate was washed with phosphate-buffered saline with 0.5% Tween. Proteins and positive control antibodies were horseradish peroxidase (HRP) (Sigma) and murine anti-HRP (Zymed Laboratories); diphtheria toxoid (DT) (ICN) and horse anti-DT (Connaught Laboratories); keyhole limpet hemocyanin (KLH) and rabbit anti-KLH (Cappel Laboratories); TT (Connaught Laboratories) and murine anti-TT antibody (Boehringer Mannheim); and tryptophan (TrpR) repressor and rabbit anti-TrpR.

Reactivity was also determined in a spot-blot assay in which mixtures of proteins were immobilized on a support filter (Immobilon AV; Millipore) and a large plaque containing human antibody fragment was lifted with the treated

filter. Detection of antibody on the filter was done with rabbit anti-human IgG followed by goat anti-rabbit immunoglobulin coupled to alkaline phosphatase for development of color in the presence of the substrate.

Affinity Measurement. We used a variation of a method developed by Olsen *et al.* (36). An anti-decapeptide antibody (26) was covalently attached to Sepharose beads. This served to bioselectively immobilize the *E. coli*-produced Fab fragments, which carry the decapeptide tag at the C terminus of the H fragment (see Fig. 3). To measure antigen binding, a sample of immobilized human antibody fragments was incubated for 2 hr with a known concentration of ^{125}I -TT. Beads were separated rapidly from supernatant by centrifugation through phthalate oil (37). The radioactivity associated with the beads was corrected for nonspecific binding by subtraction of a negative control sample. The radioactivities associated with beads or supernatant were used to calculate the concentrations of bound antigen ($[\text{Ab} - \text{Ag}]$) or free antigen ($[\text{Ag}]$). The unbound antibody concentration ($[\text{Ab}]$) is calculated from $[\text{Ab}]_{\text{total}} = [\text{Ab} - \text{Ag}] + [\text{Ab}]$. The association constant is given by the equation $K_a = [\text{Ab} - \text{Ag}]/[\text{Ab}][\text{Ag}]$.

RESULTS AND DISCUSSION

Before immunization, the frequency of circulating B cells producing anti-TT IgG was $<1/500,000$ lymphocytes in an ELISPOT assay. Six days postimmunization, the frequency increased considerably, up to $1/3000$ in one individual. This was consistent with previous data (27). Lymphocytes ($\approx 5 \times 10^8$) were isolated from 150 ml of whole blood from a donor with an increase in titer of anti-TT IgG. From these cells, 160 μg of total RNA was isolated. After first-strand synthesis conversion of mRNA to cDNA, separate PCRs were carried out for each primer pair (Fig. 2). An ≈ 700 -base-pair PCR product was observed for each matched pair of primers, as dictated by the designated location of primers.

Determination of Positive Clones. L-chain and H-chain PCR products were separately gel isolated, ligated into the appropriate ImmunoZAP vector, and packaged to create bacteriophage libraries. This gave a tetanus ImmunoZAP H library in which 68% of the clones expressed an H fragment and a tetanus ImmunoZAP L library expressing L(κ) in 67% of the clones. These two libraries were combined into a single vector to create a combinatorial immunoeexpression library (Fig. 3). The current system does not select against vectors without two inserts; therefore, in the anti-TT coexpression library, the percentage of plaques expressing both H fragment and L-chain was expected to be, at most, 46%. A total of 12,000 plaques, with ^{125}I -TT as a probe, gave 10 positive clones that were validated by duplicate lifts and a secondary screen. The frequency of positive clones found in this library, of which we have screened only a small portion, was thus 0.2%. The combinatorial library constructed here, of $\approx 10^7$ members, we estimate contains $\approx 20,000$ positive clones.

DNA Analysis. The Lambda ZAP II vector cloning system, which forms the basis of this method, allows for excision of a plasmid containing the insert (34). Restriction map analysis of plasmids from positive clones indicated the presence of both L- and H-chain genes. In addition, DNA sequencing of the H chains verified that they are derived from human IgG. The sequence for the 3' end of the CH1 domain exon matched a published IgG1 sequence, but we found AGA (arginine) for the Eu 214 residue condon, whereas AAA (lysine) is listed (30). However, either arginine or lysine may appear at this position (30), suggesting that we have cloned an allotypic variant. DNA sequence analysis of V_H and V_L domains from four positive clones indicates that each is a distinct clone.

Protein Analysis. The ability of protein G to bind to the Fab portion of IgG was exploited to isolate our human antigen binding fragments from *E. coli* supernatant. The purified protein retained binding activity to TT in an ELISA and in the affinity assay. SDS/PAGE analysis of purified protein yielded a band corresponding to 48 kDa. Upon reduction, this band resolved to a doublet of ≈ 25 kDa (data not shown). In a Western blot analysis, bands reacting with either anti-human H+L or anti-human L(κ) antibodies corresponded to the locations found for the purified protein. The same behavior was exhibited by the proteolytically generated human Fab. These data indicate that our antigen binding fragments are composed of human H-chain Fd-like fragment covalently coupled by a reducible bond to human L chain to form an Fab-like fragment.

Competitive Inhibition. The binding of radiolabeled antigen was demonstrated in the filter hybridization screen. This binding was inhibited by unlabeled TT in a concentration-dependent fashion and exhibited half-maximal inhibition at ≈ 1 nM (Fig. 4, columns A and B). Positive controls behaved in a similar manner (columns D and E). For a plaque corresponding to a negative clone (column C) or for an irrelevant antibody (column F), no signal above background could be observed. Thus, the binding of ^{125}I -TT was not an artifact caused by the radiolabeling method and correlates with positive clones.

Affinity for TT. To quantify the equilibrium association constant for binding TT, direct binding assays were done. For our human antibody fragments, the average apparent affinity constant was $9 \times 10^8 \text{ M}^{-1}$ with a range of $30 \times 10^8 \text{ M}^{-1}$ to $0.09 \times 10^8 \text{ M}^{-1}$. For comparison, the apparent affinity for antigen binding of a hybridoma-derived monoclonal murine anti-TT antibody was measured to be $0.4 \times 10^8 \text{ M}^{-1}$. The low effective concentration of antigen used for the filter hybridization screening may have allowed for discrimination of high-affinity clones since $0.2 \text{ nM } ^{125}\text{I}$ -TT was sufficient to identify a positive clone.

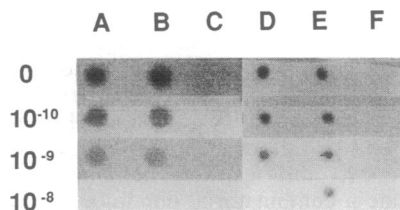

FIG. 4. For a competitive inhibition assay, antibody was adsorbed onto nitrocellulose filter strips. Columns: A and B, anti-TT human antibody fragment from plaque lifts; C, a negative plaque; D, $1 \mu\text{l}$ of human polyclonal anti-TT antibody (1:10 diluted donor serum); E, $1 \mu\text{l}$ (100 ng) of murine monoclonal anti-TT; F, 50 ng of murine anti-CD8. Competitive inhibition experiments were performed by incubating the filter strips with unlabeled TT [concentration (M) is indicated on the left] in the presence of $0.1 \text{ nM } ^{125}\text{I}$ -TT. The resulting autoradiographs were digitized (Stratascan; Strata-gene).

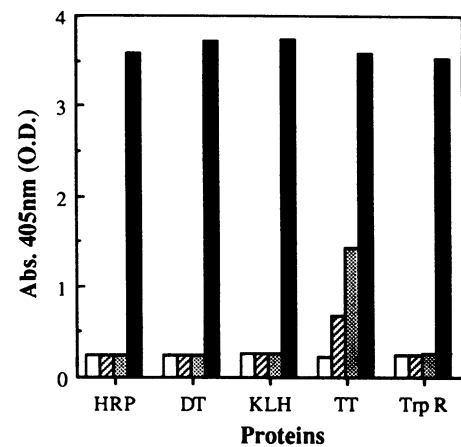

FIG. 5. Reactivity of human Fab clones were compared, by ELISA, to that of control antibodies. Target proteins were HRP, DT, KLH, TT, and TrpR. Two different positive clones, at 0.5 and $1.2 \mu\text{g/ml}$, are represented by the hatched and stippled bars, respectively. Background is represented by the open bar and the positive control is represented by the solid bar.

Specificity for TT. The human antigen binding fragments produced were not only of high affinity but also appeared to be specific. The human antigen binding fragments did not react in an ELISA with any protein other than TT (Fig. 5). In addition, the clones did not appear to bind to proteins in fetal bovine serum, hydrated milk powder, or *E. coli* lysate in a spot-blot assay but it did associate strongly with TT (data not shown).

Summary. We have obtained a repertoire of monospecific human antibody fragments with a subset capable of high-affinity binding to a complex antigen. This was done by immortalizing, in a λ bacteriophage library, an individual human immune repertoire that had been purposely biased by stimulation with a predetermined antigen. This may be useful for further explorations such as how an immune response initiates and matures. The anti-TT human antibody fragments we have identified here may be of use in passive immunotherapy. Development of some potentially useful therapeutics may require the selection of human antibodies that occur at much lower frequency in the repertoire and thus are difficult to obtain by hybridoma methodology. This will be the case for antigens that elicit a negligible human immune system response. For those cases, a large number of clones may have to be screened to allow for identification of high-affinity positive clones. However, the immunoprecipitation library system allows for the necessarily high throughput. As many as 10^6 clones can be screened in several days and a typical library may contain enough members to carry out this process many times. Human antibody fragments to viral or bacterial antigens or to autoimmune disease-related or tumor-associated self-antigens could be obtained with the method presented here and could be used in the management of human disease.

We thank Eric Elgin, Thomas Tomzynski, Ronin McManamon, and Mark Kaderli for assistance; Drs. Mario Bourdon, Waldemar Lernerhardt, and Richard Insel for experimental advice; and Susan Jones for artwork. This research was partially supported by National Institutes of Health Grant CA-36448-08 (J.A.S.).

1. Dillman, R. O. (1990) *Antibody Immunoconjugates Radiopharm.* 3, 1-15.
2. Carson, D. A. & Freemark, B. D. (1986) *Adv. Immunol.* 38, 275-311.
3. Glassey, M. C. & Dillman, R. O. (1988) *Mol. Biother.* 1, 7-12.
4. Boyd, J. & James, K. (1989) in *Advances in Biotechnological Processes*, ed. Mizrahi, A. (Liss, New York), Vol 11, pp. 2-43.

5. Boulianne, G. L., Hozumi, N. & Shulman, M. J. (1984) *Nature (London)* **312**, 643–646.
6. Morrison, S. L., Johnson, M. J., Herzenberg, L. A. & Oi, V. T. (1984) *Proc. Natl. Acad. Sci. USA* **81**, 6851–6855.
7. Neuberger, M. S., Williams, J. T., Mitchell, E. B., Jouhal, S. S., Flanagan, J. G. & Rabbitts, T. H. (1985) *Nature (London)* **314**, 268–270.
8. Takeda, S.-i., Naito, T., Hama, K., Noma, T. & Honjo, T. (1985) *Nature (London)* **314**, 452–454.
9. Brown, B. A., Davis, G. L., Saltzberger-Muller, J., Simon, P., Ho, M.-K., Shaw, P. S., Stone, B. A., Sands, H. & Moore, G. P. (1987) *Cancer Res.* **47**, 3577–3583.
10. Nishimura, Y., Yokoyama, M., Araki, K., Ueda, R., Kudo, A. & Watanabe, T. (1987) *Cancer Res.* **47**, 999–1005.
11. Liu, A. Y., Robinson, R. R., Hellstrom, K. E., Murray, E. D., Chang, C. P. & Hellstrom, I. (1987) *Proc. Natl. Acad. Sci. USA* **84**, 3439–3443.
12. Sun, L. K., Curtis, P., Rakowitz-Szulczynska, E., Ghayeb, J., Chang, N., Morrison, S. L. & Koprowski, H. (1987) *Proc. Natl. Acad. Sci. USA* **84**, 214–218.
13. Shaw, D. R., Khazaeli, M. B., Sun, L. K., Ghayeb, J., Daddona, P. E., McKinney, S. & LoBugilo, A. F. (1987) *J. Immunol.* **138**, 4534–4538.
14. Beidler, C. B., Ludwig, J. R., Cardenas, J., Phelps, J., Papworth, C. G., Melcher, E., Sierzega, M., Myers, L. J., Unger, B. W., Fisher, M., David, G. S. & Johnson, M. J. (1988) *J. Immunol.* **141**, 4053–4060.
15. Jones, P. T., Dear, P. H., Foote, J., Neuberger, M. S. & Winter, G. (1986) *Nature (London)* **321**, 522–525.
16. Riechman, L., Clark, M., Waldman, H. & Winter, G. (1988) *Nature (London)* **332**, 323–327.
17. Verhoeven, M., Milstein, C. & Winter, G. (1988) *Science* **239**, 1534–1536.
18. Queen, C., Schneider, W. P., Selick, H. E., Payne, P. W., Landolfi, N. F., Duncan, J. F., Avalovic, N. M., Levitt, M., Junghans, R. P. & Waldmann, T. A. (1989) *Proc. Natl. Acad. Sci. USA* **86**, 10029–10033.
19. Xiang, J., Roder J. & Hozumi, N. (1990) *Antibody Immunoconjugates Radiopharm.* **3**, 87 (abstr.).
20. Orlandi, R., Gussow, D. H., Jones, P. T. & Winter, G. (1989) *Proc. Natl. Acad. Sci. USA* **86**, 3844–3837.
21. Chiang, Y. L., Sheng-Dong, R., Brow, M. A. & Larrick, J. W. (1989) *BioTechniques* **7**, 360–366.
22. Larrick, J. W., Danielsson, L., Brenner, C. A., Wallace, E. F., Abrahamson, M., Fry, K. E. & Borrebaeck, C. A. K. (1989) *Bio/Technology* **7**, 934–938.
23. Loh, E. Y., Elliot, J. F., Cwirala, S., Lanier, L. L. & Davis, M. M. (1989) *Science* **243**, 217–219.
24. Sastry, L., Alting-Mees, M., Huse, W. D., Short, J. M., Sorge, J. A., Hay, B. N., Janda, K. D., Benkovic, S. J. & Lerner, R. A. (1989) *Proc. Natl. Acad. Sci. USA* **86**, 5728–5732.
25. Ward, E. S., Gussow, D., Griffiths, A. D., Jones, P. T. & Winter, G. (1989) *Nature (London)* **341**, 544–546.
26. Huse, W. D., Sastry, L., Iverson, S. A., Kang, A. S., Alting-Mees, M., Burton, D. R., Benkovic, S. J. & Lerner, R. A. (1989) *Science* **246**, 1275–1281.
27. Bizzini, B. (1979) *Microbiol. Rev.* **43**, 224–240.
28. Stevens, R. H., Macy, E., Morrow, C. & Saxon, A. (1979) *J. Immunol.* **122**, 2498–2504.
29. Czerkinsky, C. C., Nilsson, L.-A., Nygren, H., Ouchterlony, O. & Tarkowski, A. (1983) *J. Immunol. Methods* **65**, 109–121.
30. Kabat, E. A., Wu, T. T., Bilofsky, H., Reid-Milner, M. & Perry, H., eds. (1987) *Sequences of Proteins of Immunological Interest* (U.S. Public Health Service, Washington, DC).
31. Better, M., Chang, C. P., Robinson, R. R. & Horwitz, A. H. (1988) *Science* **240**, 1041–1043.
32. Jatou, J.-C., Klinman, N. R., Givol, D. & Sela, M. (1968) *Biochemistry* **7**, 4185–4190.
33. Edmundson, A. B., Ely, K. R. & Herron, J. N. (1984) *Mol. Immunol.* **21**, 5612–5620.
34. Short, J. M., Fernandez, J. M., Sorge, J. A. & Huse, W. D. (1988) *Nucleic Acids Res.* **16**, 7583–7600.
35. Erntell, M., Myhre, E. B., Sjobring, U. & Bjork, L. (1988) *Mol. Immunol.* **25**, 121–126.
36. Olsen, W. C., Spitznagel, T. M. & Yarmush, M. L. (1989) *Mol. Immunol.* **26**, 129–136.
37. Segal, D. & Hurowitz, E. (1977) *J. Immunol.* **118**, 1338–1344.