

## A novel method for site-directed mutagenesis: its application to an eukaryotic tRNA<sup>Pro</sup> gene promoter

Cinzia Traboni, Gennaro Ciliberto<sup>1\*</sup>, and Riccardo Cortese<sup>1</sup>

I Istituto di Chimica Biologica, II Facoltà di Medicina e Chirurgia, University of Naples, Naples, Italy, and <sup>1</sup>European Molecular Biology Laboratory, Postfach 102209, 6900 Heidelberg, FRG

Communicated by R. Cortese  
Received on 10 March 1982

**We present a novel general method for localized mutagenesis. The DNA segment to be mutagenized is inserted in the  $\beta$ -galactosidase gene of a M13-*lac* vector, generally causing loss of  $\beta$ -galactosidase function by generation of frameshifts or nonsense codons. Mutations in the inserted DNA which restore  $\beta$ -galactosidase function are readily detected and analyzed. The application of this method to the promoter of an eukaryotic (*Caenorhabditis elegans*) tRNA<sup>Pro</sup> gene has allowed the isolation of several mutants altered in transcription.**

**Key words:** *pol*III promoter/site-directed mutagenesis/tDNA/transcription

### Introduction

In recent years the understanding of the mechanism of transcription of eukaryotic genes has been the goal of a considerable amount of work. Several purified genes have been accurately and efficiently transcribed *in vivo* or *in vitro* (Brown, 1981; Brown and Gurdon, 1977; Probst *et al.*, 1979; Kressmann *et al.*, 1978; Cortese *et al.*, 1978; Manley *et al.*, 1980; Grummt, 1981) and DNA sequences essential for transcription have been identified on the basis of the correlation between *in vitro* induced mutations and their effect on gene expression (Grosschedl and Birnstiel, 1980a, 1980b; Benoist and Chambon, 1981; Mathis and Chambon, 1981; Hofstetter *et al.*, 1981; Galli *et al.*, 1981; Ciliberto *et al.*, 1982a, 1982b; Ciampi *et al.*, 1982). In our previous studies (Ciliberto *et al.*, 1982a, 1982b; Ciampi *et al.*, 1982) we have analyzed the transcriptional properties of a series of insertion and deletion mutants of tDNA<sup>Pro</sup> from *Caenorhabditis elegans* and reached the conclusion that the tDNA<sup>Pro</sup> promoter is composed of two separated internal control regions which are essential for the interaction with the transcriptional apparatus. Transcription is influenced by, but does not depend on, any specific information contained between these two essential regions. It is clear that more and more information will be gained by the development of rapid and efficient techniques to mutagenize DNA.

A general protocol for mutagenesis of purified genes must provide: (i) an efficient method to induce mutations; (ii) a way to confine the mutagenic event to preselected regions of DNA; and (iii) a rapid method for the identification of mutant clones. This last point is seldom a problem for prokaryotic genes or, in general, for genes that are expressed in bacteria; in this case it is usually possible to devise screening or selection procedures for the desired mutants. This becomes, however, a problem when the gene to be muta-

genized is not expressed in bacteria, as is often the case for DNA derived from eukaryotic organisms.

We have developed a method to associate to any DNA segment cloned in *Escherichia coli* a phenotype directly detectable at the level of plaque or colony. In the first part of this paper we describe the specific advantages and potential developments of this new general method, in the second part we present the results obtained with mutants of tRNA<sup>Pro</sup> gene and provide direct evidence that the sequence coding for the D-loop (Box A) plays an essential role in promotion of transcription.

### Results

#### *Convenient properties of M13-derived vectors*

In recent years a series of vectors (the mp family) derived from M13 phage has been constructed (Gronenborn and Messing, 1978; Rothstein *et al.*, 1980; Messing *et al.*, 1981) and widely used. All the vectors of this family contain a portion of the *lac* gene of *E. coli* including operator, promoter, and the region coding for 145 amino acids at the amino terminus of  $\beta$ -galactosidase (the so-called  $\alpha$ -peptide); this part of  $\beta$ -galactosidase is not a functional enzyme. The host *E. coli* strain 71-18 is deleted for chromosomal  $\beta$ -galactosidase gene but carries an episome coding for a defective  $\beta$ -galactosidase, missing amino acid residues 11–41. When mp phages invade the host the two defective  $\beta$ -galactosidase polypeptides associate and complement each other, thus producing a functional enzyme. Plaques of infected cells producing  $\beta$ -galactosidase are readily identified by including a lactose analog 5-bromo-4-chloro-3-indolyl-D-galactoside (BCIG) on the plaque: this colorless compound is hydrolysed by  $\beta$ -galactosidase to a blue dye which confers a blue perimeter to the plaques of mp phages. By contrast, recombinant phages, in which foreign DNA has been inserted in a restriction site within the  $\alpha$ -peptide of  $\beta$ -galactosidase, usually yield white plaques: the inserted DNA interrupts the  $\alpha$ -peptide and destroys its ability to complement the defective episomal  $\beta$ -galactosidase.

This last statement needs to be qualified. The NH<sub>2</sub>-terminal part of the  $\beta$ -galactosidase gene (where all the unique restriction sites used for cloning are located) is known to be non-essential for its enzymatic activity. An active enzyme can be obtained from genes which contain considerable alterations in this part of the sequence. The insertion of foreign DNA will inactivate the  $\beta$ -galactosidase gene and yield a white plaque only when it causes a frameshift or if it contains nonsense codons in frame with  $\beta$ -galactosidase. Insertion of a segment of DNA, whose length in nucleotides is a multiple of three (and therefore does not affect the reading frame of  $\beta$ -galactosidase) and which does not contain in-frame nonsense codons, will not destroy the  $\beta$ -galactosidase gene and will therefore yield a blue plaque. We have so far found no exception to this rule. This property can be exploited for site-directed or localized mutagenesis.

*Direct identification of mutants by frame-dependent phenotype*

Figure 1 is a diagram which schematically describes the

\*To whom reprint requests should be sent.

principle of the method. A DNA segment inserted into mp phage vectors will yield blue plaques if its length in nucleotides is a multiple of three. The insertion of a segment of DNA  $(3 \times N) + a$  (with  $a$  equal to 1 or 2) nucleotides long (for the sake of simplicity we assume that it does not contain nonsense codons) will give rise to a white plaque. From this, a blue plaque can be obtained as a consequence of a deletion of  $3 \times N + a$  nucleotides or an insertion of  $3 \times N - a$  nucleotides (where  $N$  can obviously be zero). It is useful to indicate the correct reading frame, coding for an active  $\beta$ -galactosidase, as  $F_{123}$ , where the subscripts stand for the first, the second, and the third nucleotides of any codon. Insertion of  $3 \times N + 1$  or deletion of  $3 \times N + 2$  nucleotides will cause a shift to a different reading frame ( $F_{312}$ ), where the first nucleotide of all original codons now appears as the second base. Insertion of  $3 \times N + 2$  or deletion of  $3 \times N + 1$  will give rise to a frame  $F_{231}$ . Even though deletions or insertions causing restoration of the frame can also occur outside the inserted segment, this

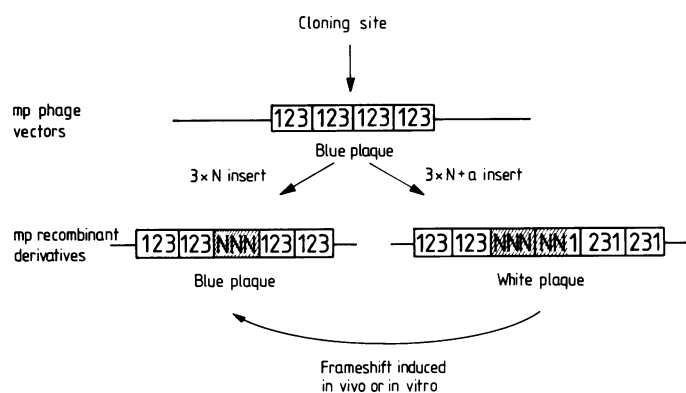

**Fig. 1.** Schematic diagram of the mutagenesis method. Boxed numbers represent triplets coding for the  $\alpha$ -peptide of  $\beta$ -galactosidase. 1, 2, and 3 stand for the first, second and third nucleotides of every codon in the original correct reading frame. Hatched boxes represent foreign inserts whose nucleotides are indicated by N. Thin lines are the rest of mp DNA.

constitutes the largest part of the potential target region. Obviously, it is possible to isolate insertion and deletion mutations by introducing a frameshift which will convert a blue phenotype into a white phenotype. This strategy is, however, less convenient, because the potential target for mutagenesis is the whole  $\alpha$ -peptide segment.

#### The *tRNA<sup>Pro</sup>* gene

The sequence of *tDNA<sup>Pro</sup>* has been published (Ciliberto *et al.*, 1982a): two *Hae*III recognition sites delimit the coding region, which can easily be subcloned with the help of molecular linkers, yielding *tDNA<sup>Pro</sup>* derivative subclones which are active in transcription. For most of the experiments we have used subclone B78R or subclone WS (Figure 2), both carrying an insert of  $3 \times N + 2$  nucleotides and yielding white plaques because of a shift from  $F_{123}$  to  $F_{231}$ . Experimental details explaining the construction of these subclones are in the legend to Figure 2.

#### *In vivo* ICR mutagenesis

ICR191 is a well known mutagen (Miller, 1972) which causes insertion of nucleotides within runs of G-C residues. When clones B78R or WS were exposed to ICR and then plated on indicator plates, several blue plaques were obtained ( $\sim 2$  blue/ $10^4$  white). Sequence analysis revealed three classes of mutants shown in Figure 2: WS I<sub>1</sub> from WS mutagenesis and B78R I<sub>1</sub> and B78R I<sub>2</sub> from B78R mutagenesis. As was to be expected, the mutations are all due to the insertions of single nucleotides in runs of G-C base pairs. With the two insertions obtained from the mutagenesis of B78R, an amber codon appears in the  $\beta$ -galactosidase frame, (indicated in Figure 2 by a hatched box) but blue plaques are nonetheless obtained because strain 71-18 carries a *supE* amber suppressor.

#### *In vitro* DNase induced deletions and insertions

The ICR mutagenesis has limited targets in a DNA segment, due to its sequence specificity: furthermore it can only

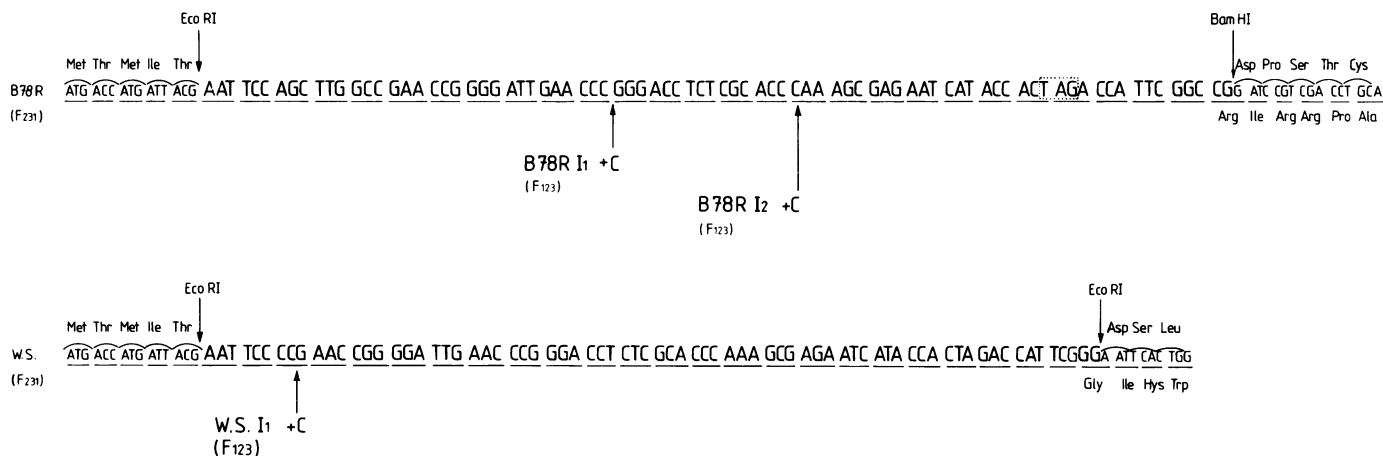

**Fig. 2.** ICR191 mutagenesis of *tDNA<sup>Pro</sup>*. B78R was constructed using mp701 as cloning vector. The *tDNA<sup>Pro</sup>* insert, indicated with large letters, derives from plasmid Mcet11 (Ciliberto *et al.*, 1982a), where the *Hind*III site was filled in with *E. coli* DNA polymerase Klenow fragment and then joined to *Eco*RI linkers. The resulting *Eco*RI-*Bam*HI segment,  $3 \times 27 + 2$  nucleotides in length, was cloned in mp701, giving rise to white plaques because of its  $F_{231}$  frame. WS was constructed using the original mp2 phage as cloning vector. *Eco*RI linkers were joined to both sides of the *tDNA<sup>Pro</sup>* *Hae*III-*Hae*III segment; during the cloning into mp2 a deletion of one C-G base pair occurred (L. Castagnoli, unpublished results) giving rise to a segment of  $3 \times 24 + 2$  nucleotides in length. This gives white plaques because of its  $F_{231}$  frame. Lower case letters indicate nucleotides belonging to the  $\beta$ -galactosidase gene, grouped (with arcs) in triplets representing the correct codons (or frame  $F_{123}$ ) corresponding to the amino acids indicated above them. Under them, and all along the inserted DNA, nucleotides are grouped (with straight lines) in triplets representing codons of frame  $F_{231}$ . In the sequence following the insert we have indicated both the amino acids coded by the original  $F_{123}$  frame and those resulting from the  $F_{231}$  frame. For the sake of simplicity we have indicated only one strand, corresponding to the mRNA sequence of  $\beta$ -galactosidase. *tDNA<sup>Pro</sup>* sequence corresponds to the coding DNA (complementary to *tRNA<sup>Pro</sup>* identical sequence).

give single base-pair insertions. To obtain a more random collection of insertion and deletion mutants we have treated purified double-stranded DNA from clone WS with DNase I and DNA polymerase I. It is known that in the presence of  $Mn^{2+}$ , DNase I introduces multiple nicks, which, under carefully controlled conditions, will result in linearization of the plasmid DNA with small regions of protruding single-stranded DNA (Shenk *et al.*, 1976; Lutter, 1977; Heffron *et al.*, 1978) which can be converted to blunt ends following incubation with DNA polymerase I holoenzyme, in the presence of the four nucleotide triphosphates. Following this treatment, WS DNA was ligated and used to transform *E. coli* strain 71-18; a large number of blue plaques were obtained ( $\sim 1$  blue/ $10^3$  white). We have sequenced DNA from five blue clones, all of which present mutations in the tDNA<sup>Pro</sup> insert. Their sequences are shown in Figure 3. With this procedure we obtained a wider spectrum of mutants, though it is evident that DNase I has a certain preference for specific sites (Anderson, 1981).

#### Single base-pair substitution mutants

A nonsense codon within a 3 x N segment of DNA will cause the formation of a white plaque; such a codon can itself be the target of site-directed mutagenesis, because mutations converting the nonsense into a sense triplet will cause the formation of blue plaques. In addition, as shown by Bossi and Roth (1980) the sequence surrounding the nonsense triplet influences the efficiency of suppression. This effect can be exploited for the purpose of mutagenesis. In particular, strain 71-18 carries a *supE* suppressor, efficiently suppressing the amber codon in mutants B78R I<sub>1</sub> and B78R I<sub>2</sub>, giving a blue plaque phenotype. This is in agreement with the hypothesis

(Bossi and Roth, 1980) that a purine following the amber codon increases the efficiency of its suppression by *supE*. In the tDNA<sup>Pro</sup> sequence another amber triplet can be put in frame by inverting the orientation of the insert of the WS I<sub>1</sub> mutant as shown in Figure 4. This triplet is not efficiently suppressed in 71-18 and WS I<sub>1</sub>\* forms white plaques. Mutagenesis of WS I<sub>1</sub>\* can generate blue plaques either by reversion of the amber codon to a sense codon or by base-pair changes in the sequence surrounding the nonsense triplet, resulting in a new context compatible with efficient suppression.

We have subjected a WS I<sub>1</sub>\* culture to the action of aminopurine, a mutagen specific for A-T to G-C transitions (Miller, 1972), and obtained two different mutants, shown in Figure 4. As predicted, one is a reversion of TAG to CAG (AP1), the other belongs to the class of context mutants, because the amber triplet is still present but is now efficiently suppressed, because the preceding GTC triplet is changed into a GCC triplet (AP3). More mutants of this type were obtained using nitrosoguanidine, which causes mostly G-C to A-T transitions (Miller, 1972). In this case, we expected predominantly context mutants because a G-C to A-T transition in the amber triplet TAG could only generate a TAA nonsense triplet, giving white plaques indistinguishable from the parental phenotype. Sequence analysis of the blue plaques obtained following treatment with nitrosoguanidine revealed only context mutants in codons preceding the amber triplet (NG2, NG3, NG6) (Figure 4). The efficiency of mutagenesis for aminopurine was of 1 blue/ $10^4$  white plaques, whereas nitrosoguanidine gave  $\sim 1$  blue/ $10^3$  white plaques under the condition used.

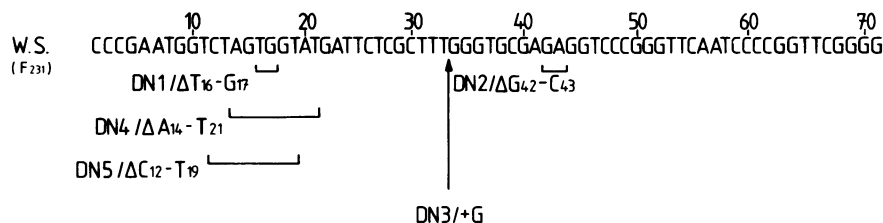

Fig. 3. DNase mutagenesis of tDNA<sup>Pro</sup>. The tDNA<sup>Pro</sup> subclone used is the WS DNA shown in Figure 2 (F<sub>231</sub>). Here we have represented the strand complementary to that shown in Figure 2, which now corresponds to the sequence found in tRNA<sup>Pro</sup>. The numbers indicate the position occupied by each nucleotide in the corresponding tRNA<sup>Pro</sup> sequence. A horizontal squared bracket comprising deleted nucleotides corresponds to each mutant. The insertion in the case of DN3 is represented by an arrow.

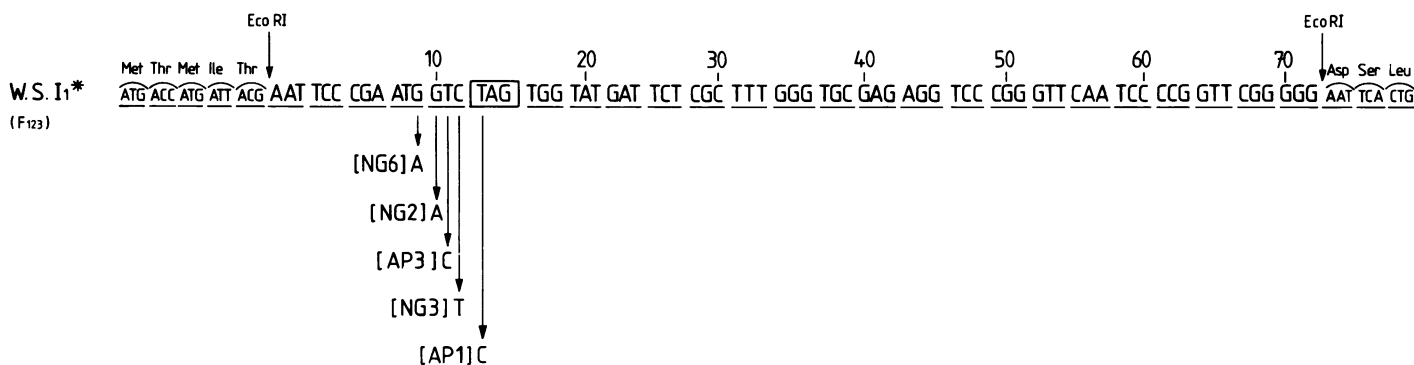

Fig. 4. Aminopurine and nitrosoguanidine mutagenesis of tDNA<sup>Pro</sup>. WS I<sub>1</sub>\* is a derivative of WS I<sub>1</sub> described in Figure 2. We have inverted the orientation of the inserted tDNA<sup>Pro</sup> segment with respect to the mp2 vector DNA. The amber codon appearing in the F<sub>123</sub> frame is boxed. The sequence shown corresponds to the  $\beta$ -galactosidase mRNA; the sequence of the tDNA<sup>Pro</sup> insert (indicated with large letters) corresponds now to that found in tRNA<sup>Pro</sup>. The numbers indicate the position occupied by each nucleotide in the corresponding tRNA<sup>Pro</sup> sequence. NG mutants were obtained with nitrosoguanidine and AP mutants with aminopurine.

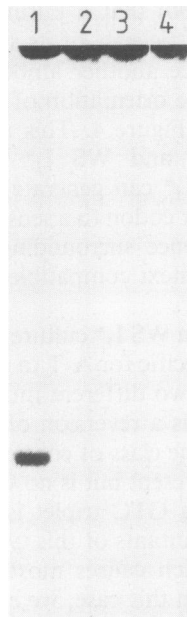

Fig. 5. Transcriptional analysis of tDNA<sup>Pro</sup> Box A mutants. Lane 1, WS; lane 2, DN1; lane 3, DN4; lane 4, DN5.

#### Transcriptional analysis of tDNA<sup>Pro</sup> mutants

In our previous studies we have shown that the promoter of tDNA<sup>Pro</sup> is composed of two essential regions: Box A, is G<sub>9</sub>G<sub>10</sub>U<sub>11</sub>C<sub>12</sub>U<sub>13</sub>A<sub>14</sub>G<sub>15</sub>U<sub>16</sub>G<sub>17</sub>G<sub>18</sub>, and Box B is G<sub>52</sub>T<sub>53</sub>T<sub>54</sub>C<sub>55</sub>A<sub>56</sub>U<sub>57</sub>C<sub>58</sub>C<sub>59</sub> (Ciliberto *et al.*, 1982a, 1982b). In the collection of mutants described here, several involve one or more nucleotides contained in the Box A component of the promoter: DN1, DN4, DN5, AP1, AP3, NG2, NG3, and NG6. We have investigated their transcriptional activity by micro-injecting their DNA into the nucleus of the *Xenopus laevis* oocytes. The results of the transcriptional analysis of the deletion mutants are presented in Figure 5 and the quantitative analysis of transcription of all mutants is shown in Table I.

All deletion mutants tested (DN1, DN4, DN5) are inactive in transcription. DN4 and DN5 carry larger deletions which include the dinucleotide (T<sub>16</sub>G<sub>17</sub>) deleted in DN1; therefore we can conclude that T<sub>16</sub>G<sub>17</sub> is an essential part of tRNA<sup>Pro</sup> gene promoter. All single base-pair mutants are active in transcription; NG6, AP3, and AP1 appear to be reproducibly more active than wild-type; the significance of this observation will be better established when our mutant collections are more complete.

#### Discussion

##### The method

We can classify the various existing methods for mutagenizing a DNA segment (reviewed by Shortle *et al.*, 1981) into two classes: (i) those allowing a localized mutagenesis of a preselected DNA region, within which mutations are randomly introduced; and (ii) those allowing a site-directed mutagenesis of a preselected base pair in a specific position of a DNA sequence.

We think that, for most purposes, localized mutagenesis should precede site-directed mutagenesis: one wants first to explore a certain region of DNA to establish the importance of specific sequences; guided by the results so obtained, one may want to use the site-directed method to define further the

Table I. Quantitation of mutant tDNA<sup>Pro</sup> transcription

DNA injected	DNA sequence of Box A	% transcription
WS (wild-type)	G G T C T A G T G G	100%
DN1	G G T C T A G(T G)G	> 1%
DN4	G G T C T(A G T G G...)	> 1%
DN5	G G(T C T A G T G G)	> 1%
WS I,* (wild-type)	G G T C T A G T G G	100%
NG6	<u>A</u> G T C T A G T G G	195%
NG2	G <u>A</u> T C T A G T G G	100%
AP3	G G <u>C</u> C T A G T G G	204%
NG3	G G <u>T T</u> T A G T G G	99%
AP1	G G T C <u>C</u> A G T G G	231%

Groups of 20 oocytes were injected with double-stranded DNAs and [ $\alpha$ -<sup>32</sup>P]GTP. After 5-h incubations the [<sup>32</sup>P]RNAs were extracted and fractionated on denaturing polyacrylamide gels (Cortese *et al.*, 1978). Bands were cut from the gel and their Cerenkov radioactivity was measured. Calculations were made by normalizing the counts against total trichloroacetic acid-precipitable material and high mol. wt. RNA (found at the top of 10% gels) (Ciampi *et al.*, 1982; Ciliberto *et al.*, 1982b). Every mutant DNA was tested at least three times with reproducible results. Letters between brackets indicate deleted nucleotides. Underlined letters indicate base-pair substitutions.

role of single nucleotides. The most general of the available methods for site-directed mutagenesis is that described by Hutchison *et al.* (1978). These workers use chemically synthesized oligodeoxynucleotides as base-specific mutagens. The oligodeoxynucleotide, containing a mismatch, is annealed to the region of DNA to be mutagenized, which must be in the single-stranded form. Then the complementary strand is synthesized *in vitro*. Following transformation, some clones should contain the desired mutation.

Several methods for localized mutagenesis have been published (Shortle and Nathans, 1978; Shortle *et al.*, 1980; Giza *et al.*, 1981). The most general is that of Shortle *et al.* (1980). Their method is based on the use of a single-stranded homologous DNA fragment to elicit the formation of a D-loop in a circular duplex DNA within a segment defined by the DNA fragment: the displaced strand can be exposed to the action of single-strand specific mutagens (to obtain base substitutions) or exposed to S1 nuclease (to obtain deletions). Following transformation, some clones should contain the desired mutations. The only limitation of this method is that, in general, mutant clones cannot be visually identified among the background carrying no mutations. This background is variable and depends on the efficiency of the strand assimilation reaction and of the mutagenic treatment. Furthermore, since the D-loop will only form on supercoiled DNA, the contaminating nicked circles, often present in supercoiled DNA preparations, will contribute to the background.

Our method is for both site-directed and localized mutagenesis with the specific feature that the mutants are unequivocally identified by the color of their plaques. This constitutes a considerable advantage, eliminating time-consuming screening. It is ideal when the properties of the mutagenized DNA can be tested at the level of small segments, as in the case of tRNA genes or of RNA polymerase II-dependent promoters. Additional work is required if the mutagenized segment must be reinserted into the context of a longer gene. A rapid and general method to reintroduce any subcloned segment of DNA in its original context may be based on *in vivo* homologous recombination: we are working in this direction.

We have used either ICR191 or DNase I as mutagens to generate insertions or deletions. For base-pair substitutions we used aminopurine or nitrosoguanidine. Mutants could be obtained in several other ways, for instance by growing the clones in a mutator strain. Unfortunately, however, the use of a mutator strain in our case only generated large deletions, removing the whole tDNA<sup>Pro</sup> coding sequence from the plasmid vector (data not shown). This need not be true for every segment of DNA, as it is known that some mutator strains, in other systems, are capable of introducing small deletions and base-pair substitutions (Lacatena and Cesareni, 1981). Perhaps the tDNA sequence is a hot spot for large deletion events.

A particularly interesting class of mutants is that obtained by changing the "context" of the amber codon. This "context" effect differs substantially from that discovered by Bossi and Roth (1980). These authors presented results leading to the conclusion that the first base of the codon adjacent to the 3' end of the amber triplet influences the efficiency of suppression. By contrast, we find that a variety of base pair changes, all in the tDNA region on the 5' side of the nonsense codon and involving nucleotides as far away as four positions from the nonsense codon, influence the efficiency of suppression. It is possible that, in our case, we are dealing with an entirely different phenomenon. Several possibilities come to mind: perhaps the target of our "context" mutations is, in reality, an attenuator sequence, responsible for termination of transcription. Alternatively, the presence of tRNA-like structures at the 5' end of the  $\beta$ -galactosidase message may be responsible for the effects observed; one could imagine that *E. coli* nucleases responsible for processing tRNA precursors may recognize this part of  $\beta$ -galactosidase RNA, thereby cleaving its 5' segment with consequent destruction of the mRNA molecule. Our mutants may be altering the interaction between the tRNA-like structure and the processing nucleases. This is unlikely, however, because one would have expected mutations scattered all along the tRNA-like sequence and not, as found, all clustered in a small region. A third hypothesis is that, during protein synthesis, the translational efficiency of a given codon may be affected by an interaction of its corresponding tRNA with the tRNA corresponding to the adjacent codons. As a consequence of base changes, different tRNAs may be involved in this type of interaction with favorable or unfavorable effects on the efficiency of translation (or suppression).

#### *The Box A component of eukaryotic tRNA gene promoters*

Abundant evidence has been provided by many authors that genes transcribed by RNA polymerase III contain sequences essential for transcription within the coding region (Sakonju *et al.*, 1980; Bogenhagen *et al.*, 1980; Fowlkes and Shenk, 1980). For tRNA genes it has been possible to reach the conclusion that the internal promoter is composed of at least two non-contiguous elements (Boxes) whose boundaries have been approximately identified on the basis of the results obtained with relatively large deletion and insertion mutants (Hofstetter *et al.*, 1981; Galli *et al.*, 1981; Ciliberto *et al.*, 1982a, 1982b). A comparison of known eukaryotic tDNA sequences (Gauss and Sprinzl, 1981), with the assumption that they have a similar promoter structure, indicated that the probable generalized sequence for Box A has the form: R<sub>9</sub>G<sub>10</sub>Y<sub>11</sub>N<sub>12</sub>N<sub>13</sub>A<sub>14</sub>R<sub>15</sub>Y<sub>16</sub>G<sub>17</sub>G<sub>18</sub> (where R, Y, and N stand for purine, pyrimidine, and any nucleotide, respectively). Our inactive mutant DN1 carries a deletion of the dinucleotide

T<sub>16</sub>G<sub>17</sub>; this provides more direct and precise evidence that the Box A component of the tRNA gene promoter includes this dinucleotide, as suggested by the generalized sequence hypothesis.

The proposal of a generalized sequence implies the assumption that a functional Box A must necessarily possess a G<sub>10</sub>, A<sub>14</sub>, G<sub>17</sub>, and G<sub>18</sub>. These could be conceived as invariant nucleotides which cannot be changed. Furthermore, it must have R<sub>9</sub>, Y<sub>11</sub>, R<sub>15</sub>, and Y<sub>16</sub>. These could be considered as semi-invariant nucleotides which can tolerate a change limited to transition. Finally, in the 12th and 13th positions, any nucleotide can be present without affecting the function of Box A; these could be viewed as variable nucleotides. The results obtained with the base-substitution mutants are only partially compatible with this hypothesis. Transitions involving semi-invariant (NG6, AP3) or variable (NG3, AP1) nucleotides do not affect transcription. In contrast to the hypothesis however, transition of the invariant G<sub>10</sub> to A<sub>10</sub> (NG<sub>2</sub>) does not affect transcription. This indicates that G<sub>10</sub> is not essential for the function of Box A and suggests a revision of the generalized sequence which could be R<sub>9</sub>R<sub>10</sub>Y<sub>11</sub>N<sub>12</sub>N<sub>13</sub>A<sub>14</sub>R<sub>15</sub>Y<sub>16</sub>G<sub>17</sub>G<sub>18</sub>.

It will be interesting to extend our mutant collection to include transversion mutants, which should have a dramatic effect in the case of the invariant and semi-invariant nucleotides, but not for the variable ones.

## Materials and methods

### *Chemicals and enzymes*

Isopropyl-D-thiogalactopyranoside and BCIG were purchased from Sigma, and recombinant DNA linkers were purchased from Collaborative Research (Waltham, MA). T4 DNA ligase, polynucleotide kinase, and all restriction endonucleases used were gifts from V. Pirrotta. DNA polymerases were purchased from Boehringer. ICR191 was a gift from J.D. Smith. DNase was from Worthington. Nitrosoguanidine was purchased from Aldrich, Europe. 2-Aminopurine was purchased from Biomol, Ilvesheim.

### *Bacterial strains, plasmids, and cloning vehicles*

*E. coli* K12 (strain 71-18) was used for transformation with phage M13 (strains mp2 and mp701) and all of its recombinant derivatives (Gronenborn and Messing, 1978; Rothstein *et al.*, 1980; Messing *et al.*, 1981). mp701 carries only the first half (from the *EcoRI* to the *PstI* site) of the polylinker contained in mp7 and was a gift from D. Bentley. Transformation of *E. coli* was as described (Cortese *et al.*, 1980).

### *In vivo mutagenesis*

Mutants were obtained by treating *E. coli* 71-18 cultures with ICR191 or aminopurine or nitrosoguanidine according to Miller (1972).

### *In vitro DNase mutagenesis*

30  $\mu$ g double-stranded WS DNA were digested with 20 ng DNase I in a freshly prepared buffer containing 50 mM Tris-HCl pH 7.6, 1 mM MnCl<sub>2</sub>, 100  $\mu$ g/ml bovine serum albumin (BSA) in a final volume of 150  $\mu$ l (Anderson, 1981). Digestion was carried out at 22°C for 1 min, resulting in disappearance of form I plasmid molecules and their conversion into forms II and III in equal amounts. The reaction was stopped with 10 mM EDTA and the DNA was extracted twice with phenol/chloroform 1:1. The DNA was then treated with 5 U of *E. coli* DNA polymerase I for 2 h at 15°C in a 50  $\mu$ l reaction mixture containing 20 mM Tris-HCl pH 7.6, 10 mM MgCl<sub>2</sub>, 1 mM 2-mercaptoethanol, 50  $\mu$ g/ml BSA, and 5  $\mu$ M for each of the deoxyribonucleotide triphosphates (Heffron *et al.*, 1978). Following phenol extraction, the DNA was ligated with T4 DNA ligase at 22°C for 24 h.

### *DNA sequence determinations*

DNA sequencing was as previously described (Schreier and Cortese, 1979).

### *Microinjections*

Microinjections into the nucleus of *X. laevis* oocytes were performed as described (Cortese *et al.*, 1978) using a 50 nl solution of DNA (200  $\mu$ g/ml) and as radioactive precursor [ $\alpha$ -<sup>32</sup>P]GTP (350 Ci/mmol, 10 mCi/ml). Twenty oocytes were injected for each sample and then incubated in Barth solution for 6 h. RNA was extracted as described (Cortese *et al.*, 1978) and fractionated on TB 10% polyacrylamide gels.

## Acknowledgements

We would like to thank V. Pirrotta and G. Cesareni for their helpful criticism. The research performed at the University of Naples was supported by a C.N.R. grant to Prof. Franco Salvatore.

## References

- Anderson, S. (1981) *Nucleic Acids Res.*, **9**, 3015-3027.
- Benoist, C., and Chambon, P. (1981) *Nature*, **290**, 304-310.
- Bogenhagen, D.F., Sakonju, S., and Brown, D.D. (1980) *Cell*, **19**, 27-35.
- Bossi, L., and Roth, J.R. (1980) *Nature*, **286**, 123-127.
- Brown, D.D. (1981) *Nature*, **211**, 667-674.
- Brown, D.D., and Gurdon, J.B. (1977) *Proc. Natl. Acad. Sci. USA*, **74**, 2064-2068.
- Ciampi, M.S., Melton, D.A., and Cortese, R. (1982) *Proc. Natl. Acad. Sci. USA*, **79**, 1388-1392.
- Ciliberto, G., Castagnoli, L., Melton, D.A., and Cortese, R. (1982a) *Proc. Natl. Acad. Sci. USA*, **79**, 1195-1199.
- Ciliberto, G., Traboni, C., and Cortese, R. (1982b) *Proc. Natl. Acad. Sci. USA*, **79**, 1921-1925.
- Cortese, R., Melton, D.A., Tranquilla, T., and Smith, J.D. (1978) *Nucleic Acids Res.*, **5**, 4593-4611.
- Cortese, R., Harland, R., and Melton, D.A. (1980) *Proc. Natl. Acad. Sci. USA*, **77**, 4147-4151.
- Fowlkes, D.M., and Shenk, T. (1980) *Cell*, **22**, 405-413.
- Galli, G., Hofstetter, H., and Birnstiel, M.L. (1981) *Nature*, **294**, 626-631.
- Gauss, D.H., and Sprinzl, M. (1981) *Nucleic Acids Res.*, **10**, r1-r23.
- Giza, P.E., Schmit, D.M., and Murr, B.L. (1981) *Gene*, **15**, 331-342.
- Gronenborn, B., and Messing, J. (1978) *Nature*, **272**, 375-377.
- Grosschedl, R., and Birnstiel, M.L. (1980a) *Proc. Natl. Acad. Sci. USA*, **77**, 1432-1436.
- Grosschedl, R., and Birnstiel, M.L. (1980b) *Proc. Natl. Acad. Sci. USA*, **77**, 7102-7106.
- Grummt, I. (1981) *Proc. Natl. Acad. Sci. USA*, **78**, 727-731.
- Heffron, F., So, M., and McCarthy, B.J. (1978) *Proc. Natl. Acad. Sci. USA*, **75**, 6012-6016.
- Hofstetter, H., Kressmann, A., and Birnstiel, M.L. (1981) *Cell*, **24**, 573-585.
- Hutchison, C.A. III, Phillips, S., Edgell, M.H., Gillam, S., Jahnke, P., and Smith, M. (1978) *J. Biol. Chem.*, **253**, 6551-6560.
- Kressmann, A., Clarkson, S.G., Pirrotta, V., and Birnstiel, M.L. (1978) *Proc. Natl. Acad. Sci. USA*, **76**, 1176-1180.
- Lacatena, R.M., and Cesareni, G. (1981) *Nature*, **294**, 623-626.
- Lutter, L.C. (1977) *J. Mol. Biol.*, **117**, 53-69.
- Manley, J.L., Fire, A., Cano, A., Sharp, P.A., and Geter, M.L. (1980) *Proc. Natl. Acad. Sci. USA*, **72**, 3855-3860.
- Mathis, D.J., and Chambon, P. (1981) *Nature*, **294**, 310-315.
- Messing, J., Crea, R., and Seeberg, P.H. (1981) *Nucleic Acids Res.*, **9**, 309-321.
- Miller, J.H. (1972) *Experiments in Molecular Genetics*, published by Cold Spring Harbor Laboratory Press, Cold Spring Harbor, NY.
- Probst, E., Kressmann, A., and Birnstiel, M.L. (1979) *J. Mol. Biol.*, **134**, 709-732.
- Rothstein, R.J., Lau, L.F., Bahl, C.P., Narang, S.A., and Wu, R. (1980) *Methods Enzymol.*, **68**, 98-109.
- Sakonju, S., Bogenhagen, D.F., and Brown, D.D. (1980) *Cell*, **19**, 13-25.
- Schreier, P.H., and Cortese, R. (1979) *J. Mol. Biol.*, **129**, 169-172.
- Shenk, T., Carbon, J., and Berg, P. (1976) *J. Virol.*, **18**, 664-671.
- Shortle, D., DiMaio, D., and Nathans, D. (1981) in Roman, H.L., Campbell, A., and Sandler, L.M. (eds.), *Annu. Rev. Genet.*, Vol. 15, Annual Reviews Inc., CA, pp. 265-294.
- Shortle, D., and Nathans, D. (1978) *Proc. Natl. Acad. Sci. USA*, **75**, 2170-2174.
- Shortle, D., Koshland, D., Weinstock, G.M., and Botstein, D. (1980) *Proc. Natl. Acad. Sci. USA*, **77**, 5375-5379.