



Laboratory Evolution of a Biotin- Requiring *Saccharomyces cerevisiae* Strain for Full Biotin Prototrophy and Identification of Causal Mutations

 Jasmine M. Bracher, Erik de Hulster, Charlotte C. Koster, Marcel van den Broek,

 Jean-Marc G. Daran, Antonius J. A. van Maris,* Jack T. Pronk

Department of Biotechnology, Delft University of Technology, Delft, The Netherlands

ABSTRACT Biotin prototrophy is a rare, incompletely understood, and industrially relevant characteristic of *Saccharomyces cerevisiae* strains. The genome of the haploid laboratory strain CEN.PK113-7D contains a full complement of biotin biosynthesis genes, but its growth in biotin-free synthetic medium is extremely slow (specific growth rate [μ] \approx 0.01 h⁻¹). Four independent evolution experiments in repeated batch cultures and accelerostats yielded strains whose growth rates ($\mu \leq$ 0.36 h⁻¹) in biotin-free and biotin-supplemented media were similar. Whole-genome resequencing of these evolved strains revealed up to 40-fold amplification of *BIO1*, which encodes pimeloyl-coenzyme A (CoA) synthetase. The additional copies of *BIO1* were found on different chromosomes, and its amplification coincided with substantial chromosomal rearrangements. A key role of this gene amplification was confirmed by overexpression of *BIO1* in strain CEN.PK113-7D, which enabled growth in biotin-free medium ($\mu =$ 0.15 h⁻¹). Mutations in the membrane transporter genes *TPO1* and/or *PDR12* were found in several of the evolved strains. Deletion of *TPO1* and *PDR12* in a *BIO1*-overexpressing strain increased its specific growth rate to 0.25 h⁻¹. The effects of null mutations in these genes, which have not been previously associated with biotin metabolism, were nonadditive. This study demonstrates that *S. cerevisiae* strains that carry the basic genetic information for biotin synthesis can be evolved for full biotin prototrophy and identifies new targets for engineering biotin prototrophy into laboratory and industrial strains of this yeast.

IMPORTANCE Although biotin (vitamin H) plays essential roles in all organisms, not all organisms can synthesize this vitamin. Many strains of baker's yeast, an important microorganism in industrial biotechnology, contain at least some of the genes required for biotin synthesis. However, most of these strains cannot synthesize biotin at all or do so at rates that are insufficient to sustain fast growth and product formation. Consequently, this expensive vitamin is routinely added to baker's yeast cultures. In this study, laboratory evolution in biotin-free growth medium yielded new strains that grew as fast in the absence of biotin as in its presence. By analyzing the DNA sequences of evolved biotin-independent strains, mutations were identified that contributed to this ability. This work demonstrates full biotin independence of an industrially relevant yeast and identifies mutations whose introduction into other yeast strains may reduce or eliminate their biotin requirements.

KEYWORDS *Saccharomyces cerevisiae*, adaptive laboratory evolution, biotin, prototrophy, reverse metabolic engineering, vitamin biosynthesis, whole-genome sequencing

Received 19 April 2017 **Accepted** 1 June 2017

Accepted manuscript posted online 9 June 2017

Citation Bracher JM, de Hulster E, Koster CC, van den Broek M, Daran J-MG, van Maris AJA, Pronk JT. 2017. Laboratory evolution of a biotin-requiring *Saccharomyces cerevisiae* strain for full biotin prototrophy and identification of causal mutations. *Appl Environ Microbiol* 83:e00892-17. <https://doi.org/10.1128/AEM.00892-17>.

Editor Dan Cullen, USDA Forest Products Laboratory

Copyright © 2017 American Society for Microbiology. All Rights Reserved.

Address correspondence to Jack T. Pronk, j.t.pronk@tudelft.nl.

* Present address: Antonius J. A. van Maris, School of Biotechnology, Division of Industrial Biotechnology, KTH Royal Institute of Technology, AlbaNova University Centre, Stockholm, Sweden.

Biotin (vitamin H or B₇) functions as an essential prosthetic group of enzymes in all three domains of life. The yeast *Saccharomyces cerevisiae* harbors four groups of biotin-dependent enzymes: (i) pyruvate carboxylases (Pyc1 and Pyc2), which catalyze anaplerotic formation of oxaloacetate (1, 2); (ii) acetyl-coenzyme A (CoA) carboxylases (Acc1 and Hfa1), which generate malonyl-CoA, the key precursor for lipid synthesis (3); (iii) urea amidolyase (Dur1 and Dur2), which releases ammonia from urea (4); and (iv) the aminoacyl-tRNA synthetase cofactor Arc1, which is the only biotin-dependent protein in *S. cerevisiae* that is not a carboxylase (5). Biotin is covalently linked to these enzymes by the biotin-protein ligase Bpl1 (6).

While biotin prototrophy is widespread among prokaryotes and plants, animals and most fungi cannot synthesize this vitamin. The final four conserved steps in prokaryotic biotin biosynthesis are initiated by conversion of pimeloyl-CoA to 7-keto-8-aminopelargonic acid (KAPA) by KAPA synthase (BioF), after which DAPA aminotransferase (BioA) transaminates KAPA to 7,8-diaminopelargonic acid (DAPA). Subsequently, dethiobiotin synthetase (BioD) converts DAPA to dethiobiotin. Finally, sulfur insertion by biotin synthase (BioB) yields biotin (7) (Fig. 1). Two pathways for prokaryotic pimeloyl-CoA synthesis have been described. Some bacteria, including *Escherichia coli*, convert three molecules of malonyl-CoA to pimeloyl-CoA (8). Others, including *Bacillus subtilis*, generate this precursor by oxidative cleavage of fatty-acyl molecules (9; reviewed in reference 10).

Biotin prototrophy is rare among yeasts and has a convoluted evolutionary history, with yeast strains of the same species sometimes exhibiting different biotin requirements. Most yeast strains isolated from nature, as well as laboratory strains, such as *S. cerevisiae* S288C, are biotin auxotrophs (11). Starting from pimelic acid, biotin biosynthesis in prototrophic yeast strains follows the prokaryotic pathway (Fig. 1), but the yeast pathway for synthesis of this key precursor has not yet been fully elucidated (10, 12, 13). Biotin biosynthesis genes in yeast are assumed to have been at least partially acquired from anaerobic bacteria by horizontal gene transfer, followed by gene duplication and neofunctionalization events (14, 15).

Most biotin-auxotrophic *S. cerevisiae* strains contain the genes encoding the last three enzymes of the biotin biosynthesis pathway (*BIO3*, *BIO4*, and *BIO2*, which are orthologs of *E. coli* *bioA*, *bioD*, and *bioB*). Some other yeasts, such as *Schizosaccharomyces pombe* and *Pichia pastoris*, contain only the biotin synthase (*BIO2*) gene, an ortholog of prokaryotic *bioB* genes. In 2005, Wu et al. discovered *BIO6*, an ortholog of bacterial *bioF* genes, in biotin-prototrophic sake strains of *S. cerevisiae* (16). Hall and Dietrich completed the *S. cerevisiae* gene set for conversion of pimelic acid to biotin by discovering *BIO1*, which encodes pimeloyl-CoA synthetase and, in strains that carry either gene, is located adjacent to *BIO6*. Sequence similarity suggests that *BIO6* evolved by duplication and neofunctionalization of *BIO3*, thereby converting a DAPA synthase into a KAPA synthetase. A similar evolutionary relationship was proposed for *BIO1* and YJR154W (14).

Lack or loss of pathways for *de novo* vitamin biosynthesis in microbes has been proposed to reflect an evolutionary trade-off between fitness in natural environments where biotin is scarce and energy costs involved in biotin synthesis (17). Consistent with this notion, biotin-prototrophic bacteria, archaea, and plants all harbor transporters for biotin uptake (18). *S. cerevisiae* imports biotin via the high-affinity proton symporter Vht1 (19). Some strains additionally harbor the Bio5 transporter, which imports the precursor KAPA, thus enabling biotin synthesis from exogenous KAPA (15, 20, 21). In *S. cerevisiae* strains that carry a *BIO5* gene, it is tightly linked to *BIO3* and *BIO4* in a gene cluster on chromosome XIV (ChrXIV) (14).

Most synthetic media for *S. cerevisiae* are routinely supplied with biotin. Vitamin addition increases production costs and decreases the shelf life of the media. Biotin supplementation adds a delicate step in medium preparation, since the high pH required for dissolving biotin negatively affects its stability, thereby increasing the risk of batch-to-batch variations. Moreover, biotin is an expensive vitamin. It has been estimated that, at a reactor volume of 150 m³, costs for large-scale industrial ferment-

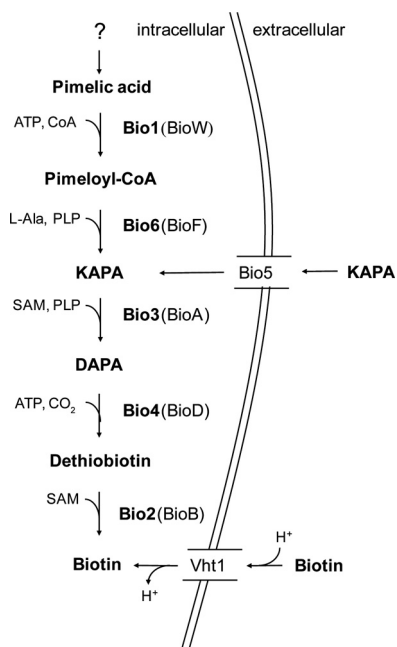

FIG 1 Biotin biosynthesis in *S. cerevisiae*. *BIO* genes encode the following enzymes: Bio1, pimeloyl-CoA synthetase; Bio6, KAPA synthetase; Bio3, DAPA aminotransferase; Bio4, dethiobiotin synthase; Bio2, biotin synthase; SAM, *S*-adenosylmethionine; and PLP, pyridoxal phosphate. The protein names in parentheses indicate the corresponding bacterial enzymes. In *S. cerevisiae*, biotin and its precursor, KAPA, can be imported via the proton symporter Vht1 and the KAPA permease Bio5, respectively.

tation processes may be on the order of \$1,000 per fermentation (22). Clearly, the availability of fast-growing biotin-prototrophic strains could benefit process economics.

Several studies have focused on engineering microorganisms for biotin prototrophy. Expression of heterologous *BIO* genes in the biotin-auxotrophic yeast *P. pastoris* reduced medium costs in fed-batch-based production processes, even though the engineered biotin-prototrophic strain grew more slowly than the reference strain (21). Enhancing biotin synthesis in solventogenic clostridia improved production titers of acetone, butanol, and ethanol, predominantly by increasing cellular viability and performance (23).

The goal of this study was to identify key genetic determinants of biotin prototrophy in *S. cerevisiae*. To this end, the haploid strain *S. cerevisiae* CEN.PK113-7D, a popular model for systems biology and metabolic-engineering research (22, 24–26), was subjected to laboratory evolution in biotin-free medium. Evolved biotin-prototrophic cell lines were further characterized by whole-genome resequencing and by reverse engineering of identified mutations in the parental strain.

RESULTS

Laboratory evolution of *S. cerevisiae* CEN.PK113-7D for full biotin prototrophy.

After inoculation of biotin-free SMD (see Materials and Methods) with a biotin-depleted preculture of strain CEN.PK113-7D, it took ca. 20 days before slow growth, at a specific growth rate of ca. 0.01 h^{-1} , was observed. At a final cell number in the shake flasks of $4 \times 10^{11} \text{ cells} \cdot \text{liter}^{-1}$ and a specific growth rate of 0.01 h^{-1} (i.e., a doubling time of 69 h), this implies an initial concentration of growing cells of at least $2 \times 10^9 \text{ cells} \cdot \text{liter}^{-1}$. These results confirm an earlier report that strain CEN.PK113-7D is not completely auxotrophic for biotin but can grow at very low rates in the absence of this vitamin (22).

To explore the evolvability of full biotin prototrophy, i.e., a phenotype with identical specific growth rates in the presence and absence of biotin, strain CEN.PK113-7D was grown in accelerostats. These are continuous cultures in which the dilution rate is increased over time (27). To select for fast-growing biotin-prototrophic mutants in

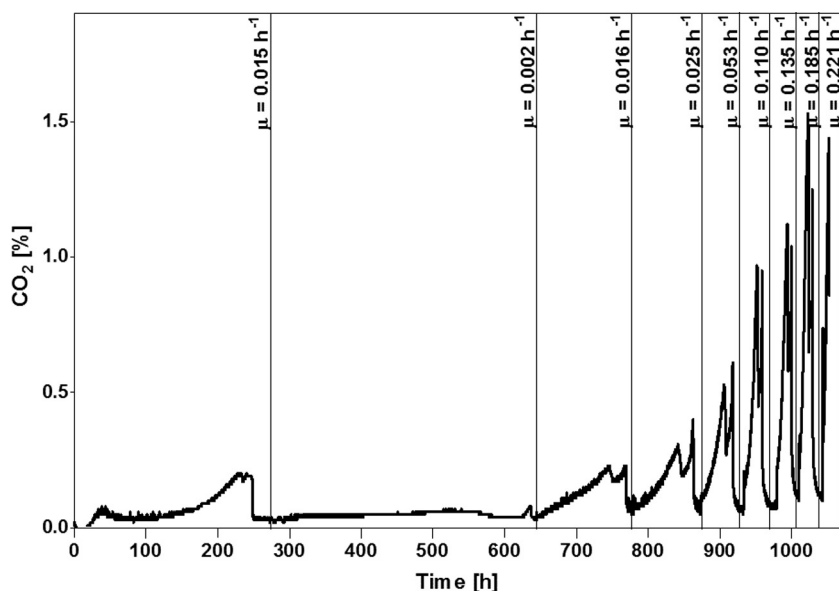

FIG 2 Laboratory evolution of *S. cerevisiae* CEN.PK113-7D cells in a sequential batch reactor (SBR) for improved growth in biotin-free synthetic medium. Shown are off gas CO₂ (percent) profiles during an SBR experiment in which automated empty-refill cycles were based on the CO₂ concentration in the off gas, leaving ca. 5% of the culture as an inoculum for each subsequent batch cycle (28). CO₂ production in the initial cycle reflects depletion of biotin pools in the inoculum. Specific growth rates (μ) were calculated from the exponential increase of the off gas CO₂ concentration in each cycle. Graphs representing the increase of dilution rates in accelerostats over time are depicted in Fig. S2 in the supplemental material.

triplicate glucose-limited accelerostat cultures on biotin-free SMD, the dilution rate was feedback controlled based on the CO₂ concentration in the off gas (see Fig. S2 in the supplemental material). A fourth laboratory evolution experiment was performed in a sequential batch reactor (SBR) in which automated empty-refill cycles were based on the CO₂ concentration in the off gas, leaving ca. 5% of the culture as an inoculum for each subsequent batch cycle (28) (Fig. 2). After 48 to 77 days of accelerostat cultivation, dilution rates of up to 0.27 h⁻¹ were reached (Fig. S2). Single cell lines were isolated at the end of each of the accelerostat experiments and named IMS0478, IMS0480, and IMS0481 (Table 1). The SBR experiment was terminated when, after 47 days and 11 cycles, multicellular aggregates appeared in the culture due to the SBR setup-inherent empty-refill selection procedure, which is prone to unintended selection of cells developing a clumping phenotype, enabling their persistence in the bioreactor without further improvement of their growth rate under selective conditions (29). At this point, the specific growth rate, as estimated from CO₂ production profiles, had reached 0.22 h⁻¹ (Fig. 2). A nonaggregating single-colony isolate from the SBR culture was named IMS0496. All four single-cell isolates showed high specific growth rates in biotin-free SMD, ranging from 0.25 h⁻¹ (strain IMS0478) to 0.36 h⁻¹ (strain IMS0481) (Table 2). This value is close to the specific growth rate of CEN.PK113-7D in biotin-supplemented SMD (0.39 to 0.40 h⁻¹) (30–33). Biotin-supplemented cultures of the evolved strains showed an average specific growth rate of 0.35 h⁻¹, indicating that the evolved strain IMS0481 had acquired full biotin prototrophy (Table 2).

Massive amplification of *BIO1* and *BIO6* and increased expression of *BIO* genes in evolved biotin-prototrophic strains. To investigate the molecular basis of the acquired biotin prototrophy, expression levels and copy numbers of *BIO* genes were measured by quantitative PCR (qPCR) analysis and whole-genome sequencing, respectively. In shake-flask cultures on biotin-supplemented SMD, transcript levels of *BIO* genes were lower than those of the reference gene, *ACT1*, in all strains tested (Fig. 3A; see Table S2 in the supplemental material). Transcript levels of *BIO* genes in the evolved strains resembled those in the parental strain, except for *BIO1*, whose transcript levels were 4- to 8-fold higher in the evolved strains. Growth in SMD without biotin resulted

TABLE 1 *S. cerevisiae* strains used in this study

Strain	Relevant genotype	Description/use	Reference
CEN.PK113-7D	<i>MATa</i>	Reference strain	39
CEN.PK113-5D	<i>MATa ura3-52</i>	Uracil-auxotrophic reference strain	39
S288C	<i>MATa</i>	Marker strain for CHEF analysis	YGSC ^a
IMX585	<i>MATa can1::CAS9-tagA-loxP-natNT2-loxP</i>	CEN.PK113-7D expressing Cas9	34
IMS0478	<i>MATa</i> , evolved	CEN.PK113-7D evolved for biotin prototrophy (accelerostat A)	This study
IMS0480	<i>MATa</i> , evolved	CEN.PK113-7D evolved for biotin prototrophy (accelerostat B)	This study
IMS0481	<i>MATa</i> , evolved	CEN.PK113-7D evolved for biotin prototrophy (accelerostat C)	This study
IMS0496	<i>MATa</i> , evolved	CEN.PK113-7D evolved for biotin prototrophy (sequential batch reactor)	This study
IME327	<i>MATa ura3-52</i> pUDE446	CEN.PK113-5D pUDE446 (<i>BIO1-BIO6</i>)	This study
IME329	<i>MATa ura3-52</i> pUDE448	CEN.PK113-5D pUDE448 (<i>BIO6</i>)	This study
IME331	<i>MATa ura3-52</i> pUDE450	CEN.PK113-5D pUDE450 (<i>BIO1</i>)	This study
IME334	<i>MATa ura3-52</i> p426GPD	CEN.PK113-5D p426GPD (empty)	This study
IMK129	<i>MATa ura3-52 tpo1::loxP-kanMX-loxP</i>	CEN.PK113-5D; <i>tpo1::loxP-kanMX-loxP</i>	This study
IMZ694	<i>MATa ura3-52 tpo1::loxP-kanMX-loxP</i> pUDE450	IMK129 (<i>tpo1Δ</i>) pUDE450 (<i>BIO1</i>)	This study
IMZ695	<i>MATa ura3-52 tpo1::loxP-kanMX-loxP</i> p426GPD	IMK129 (<i>tpo1Δ</i>) p426GPD (empty)	This study
IMK163	<i>MATa ura3-52 pdr12::loxP-kanMX-loxP</i>	CEN.PK113-5D; <i>pdr12::loxP-kanMX-loxP</i>	This study
IMZ704	<i>MATa ura3-52 pdr12::loxP-kanMX-loxP</i> pUDE450	IMK163 (<i>pdr12Δ</i>) pUDE450 (<i>BIO1</i>)	This study
IMZ705	<i>MATa ura3-52 pdr12::loxP-kanMX-loxP</i> p426GPD	IMK163 (<i>pdr12Δ</i>) p426GPD (empty)	This study
IMK773	<i>MATa ura3-52 tpo1::loxP-kanMX-loxP pdr12::hphNT1</i>	CEN.PK113-5D <i>tpo1::loxP-kanMX-loxP pdr12::hphNT1</i>	This study
IMZ701	<i>MATa ura3-52 tpo1::loxP-kanMX-loxP pdr12::hphNT1</i> pUDE450	IMK773 (<i>tpo1Δ, pdr12Δ</i>) pUDE450 (<i>BIO1</i>)	This study
IMZ702	<i>MATa ura3-52 tpo1::loxP-kanMX-loxP pdr12::hphNT1</i> p426GPD	IMK773 (<i>tpo1Δ pdr12Δ</i>) p426GPD (empty)	This study

^aYGSC, Yeast Genetic Stock Center, Berkeley, CA.

in transcriptional upregulation of *BIO* genes (Fig. 3B; see Table S2 in the supplemental material). As observed in biotin-supplemented cultures, *BIO1* was expressed at higher levels than the other *BIO* genes, reaching transcript levels that were 1.5- to 24-fold higher than those of *ACT1* (Fig. 3B).

Analysis of sequencing read depths revealed massive amplification of *BIO1* and *BIO6* in the evolved strains, with copy numbers ranging from 8 to 43 (Table 3). The similar amplifications of *BIO1* and *BIO6* observed in this analysis were consistent with their physical linkage (22). The evolved strains harbored one or two copies of *BIO2*, *BIO3*, or

TABLE 2 Specific growth rates of laboratory-evolved biotin-prototrophic *S. cerevisiae* strains and of strains carrying defined mutations grown in shake flask cultures containing synthetic media with or without biotin supplementation^a

Strain	Relevant genotype	Growth rate (h ⁻¹) in SMD	
		Without biotin	With biotin
CEN.PK113-7D	Haploid laboratory strain	<0.01	0.39 ± 0.01 ^b
IMS0478	CEN.PK113-7D evolved for biotin prototrophy (accelerostat A)	0.25 ± 0.00	0.34 ± 0.02
IMS0480	CEN.PK113-7D evolved for biotin prototrophy (accelerostat B)	0.31 ± 0.00	0.34 ± 0.00
IMS0481	CEN.PK113-7D evolved for biotin prototrophy (accelerostat C)	0.36 ± 0.00	0.41 ± 0.00
IMS0496	CEN.PK113-7D evolved for biotin prototrophy (SBR)	0.32 ± 0.01	0.31 ± 0.02
IME327	CEN.PK113-5D + pUDE446 (2μ <i>BIO1-BIO6</i>)	0.16 ± 0.01	0.32 ± 0.01
IME329	CEN.PK113-5D + pUDE448 (2μ <i>BIO6</i>)	No growth	0.30 ± 0.00
IME331	CEN.PK113-5D + pUDE450 (2μ <i>BIO1</i>)	0.15 ± 0.02	0.32 ± 0.01
IME334	CEN.PK113-5D + p426GPD (empty plasmid)	No growth	0.34 ± 0.01
IMZ694	<i>tpo1Δ</i> , pUDE450 (2μ <i>BIO1</i>)	0.23 ± 0.00	0.32 ± 0.00
IMZ695	<i>tpo1Δ</i> p426GPD (empty plasmid)	No growth	0.33 ± 0.01
IMZ704	<i>pdr12Δ</i> pUDE450 (2μ <i>BIO1</i>)	0.25 ± 0.00	0.37 ± 0.00
IMZ705	<i>pdr12Δ</i> p426GPD (empty plasmid)	No growth	0.40 ± 0.00
IMZ701	<i>pdr12Δtpo1Δ</i> pUDE450 (2μ <i>BIO1</i>)	0.25 ± 0.01	0.36 ± 0.01
IMZ702	<i>pdr12Δtpo1Δ</i> p426GPD (empty plasmid)	No growth	0.37 ± 0.00

^aCells were grown in aerobic 100-ml shake flask cultures. The data represent averages ± standard deviations of the mean of measurements of independent duplicate cultures.

^bReference 32.

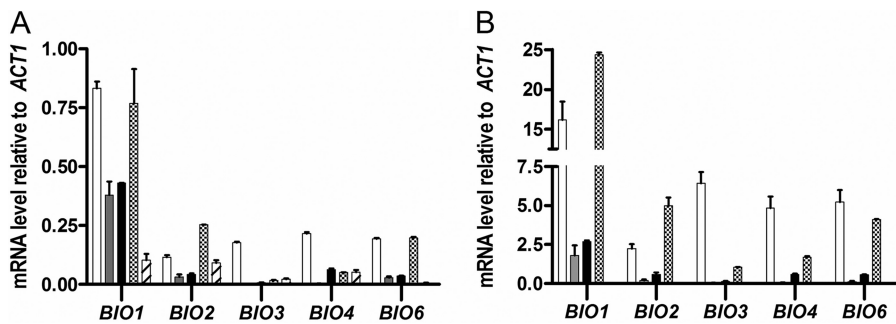

FIG 3 mRNA levels of *BIO* genes in strains evolved for biotin prototrophy. (A) Transcript levels in cultures grown on SMD with biotin. Shown are transcript levels of *BIO1*, *BIO2*, *BIO3*, *BIO4*, and *BIO6* in the parent strain, CEN.PK113-7D (hatched bars), and in the evolved strains IMS0478 (white bars), IMS0480 (gray bars), IMS0481 (black bars), and IMS0496 (cross-hatched bars) relative to *ACT1* expression levels. (B) Transcript levels in cultures grown on SMD without biotin. Shown are transcript levels of *BIO1*, *BIO2*, *BIO3*, *BIO4*, and *BIO6* in the evolved strains IMS0478 (white bars), IMS0480 (gray bars), IMS0481 (black bars), and IMS0496 (cross-hatched bars) relative to *ACT1* expression levels. All qPCR experiments were carried out on duplicate cultures, with analytical triplicates for each culture. Relative expression levels were determined according to the $\Delta\Delta C_T$ method (45). The error bars represent the SEM of duplicate analyses.

BIO4, except for the slowest-growing strain, IMS0478, in which *BIO3* and *BIO4* were amplified 8- and 6-fold, respectively.

Amplification of *BIO1* and *BIO6* involves chromosomal duplications and rearrangements and formation of neochromosomes. In three of the four evolved biotin-prototrophic strains, read depth analysis revealed a duplication of ChrI (Fig. 4), which, in the parental strain, carries the *BIO1* and *BIO6* genes (22). Strain IMS0478, which also showed increased copy numbers of other *BIO* genes, carried additional duplications of ChrIX, the left arm of ChrVIII, and an amplified region close to the telomere of the right arm of ChrXIV, where the *BIO3*-*BIO4*-*BIO5* cluster is located (Fig. 4A).

Electrophoretic karyotyping revealed strong differences in chromosome sizes between the evolved strains, as well as their common unevolved parental strain, while strains IMS0478, IMS0480, and IMS0481 contained additional, supernumerary chromosomes (neochromosomes) (Fig. 5A). Southern hybridization analysis showed that copies of the *BIO1* gene occurred on multiple chromosomes and neochromosomes in the evolved strains (Fig. 5B). This experiment confirmed that *S. cerevisiae* strain S288C, whose genomic DNA was used as a size marker for chromosome identification, lacks the *BIO1* gene (Fig. 5B) (16, 22).

Increased copy numbers of *BIO1* play a pivotal role in acquired biotin prototrophy. To investigate if the high copy numbers of *BIO1* and *BIO6* contributed to the acquired biotin prototrophy of the evolved strains, the genes were expressed from multicopy plasmids under the control of strong, constitutive promoters in a non-evolved, biotin-auxotrophic strain. Overexpression of *BIO1*, together with *BIO6*, a situation that mimicked the amplification of both genes in the evolved strains, enabled

TABLE 3 Estimated copy numbers of *BIO1*, *BIO2*, *BIO3*, *BIO4*, and *BIO6* in the evolved biotin-prototrophic strains and the parent strain, CEN.PK113-7D

Strain	Gene copy no. per strain ^a				
	<i>BIO1</i>	<i>BIO2</i>	<i>BIO3</i>	<i>BIO4</i>	<i>BIO6</i>
CEN.PK113-7D	1	1	1	1	1
IMS0478	8	2	8	6	8
IMS0480	42	2	1	1	43
IMS0481	19	2	1	1	19
IMS0496	19	2	2	1	20

^aCopy numbers were calculated from sequence coverage depths of four strains independently evolved for biotin prototrophy in accelerostats (IMS0478, IMS0480, and IMS0481) and in a sequential batch reactor setup (IMS0496). All five genes indicated occur as single-copy genes in the parental strain CEN.PK113-7D (24).

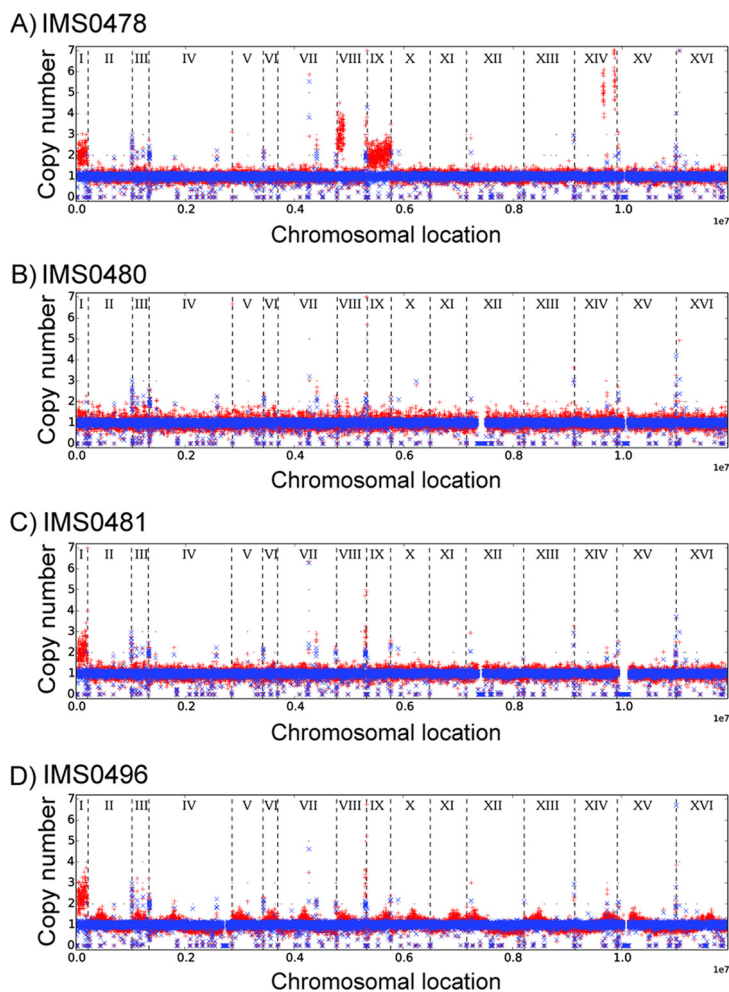

FIG 4 Chromosomal copy number variations in yeast strains evolved for full biotin prototrophy. Strains IMS0478, IMS0480, and IMS0481 were evolved in accelerostats, while strain IMS0496 was evolved in a sequential batch reactor. Copy numbers of chromosomes and chromosomal regions were calculated from sequence data with the Magnolia algorithm (67). The results for the parental strain, *S. cerevisiae* CEN.PK113-7D, and for the evolved strains are indicated in blue and red, respectively. Individual chromosomes, indicated by Roman numerals, are separated by dashed lines.

growth in SMD without biotin at a specific growth rate of 0.15 h^{-1} (Table 2). However, the same growth rate was obtained when only *BIO1* was overexpressed. Further, growth in biotin-free SMD was not observed in a strain that overexpressed only *BIO6*. These results indicated that increased copy numbers of *BIO1*, but not of *BIO6*, contributed to the acquired biotin prototrophy of evolved strains.

Mutations in the membrane transporter genes *TPO1* and *PDR12* contribute to fast growth in biotin-free medium. Although overexpression of *BIO1* in a nonevolved strain background enabled growth in biotin-free medium, the specific growth rates of the resulting strains were only about half of those observed in the fast-growing evolved strains. To further analyze the genetic basis for fast growth in biotin-free medium, the genome sequences of the evolved biotin-prototrophic strains were analyzed in more detail. The four independently evolved strains harbored 6 to 11 single-nucleotide changes within coding regions relative to the parental strain (see Table S1 in the supplemental material). Three out of the four evolved strains harbored a nonsynonymous or nonsense mutation in *TPO1*, which encodes a plasma membrane polyamine transporter (34). *TPO1* was the only gene that harbored single-nucleotide polymorphisms (SNPs) in more than one strain. However, a nonsense mutation in the ABC

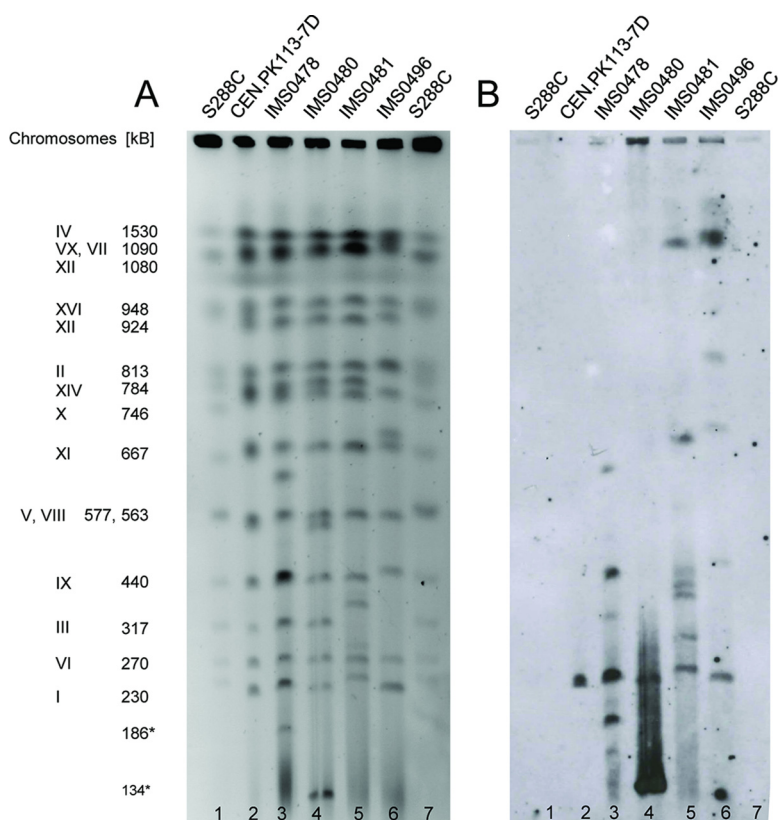

FIG 5 Karyotyping and chromosomal localization of *BIO1* in evolved biotin-prototrophic yeast strains. (A) Pulsed-field gel electrophoresis (PFGE) of the chromosomes of evolved biotin-prototrophic strains IMS0478, IMS0480, IMS0481, and IMS0496 and the parent strain, *S. cerevisiae* CEN.PK113-7D. Chromosome numbers and sizes (kilobases) were obtained using *S. cerevisiae* S288C as a reference strain. (B) Southern blot of the PFGE gel. Hybridization with *BIO1* probe revealed copies of *BIO1* on multiple chromosomes in the evolved strains.

transporter gene *PDR12* in strain IMS0481 coincided with a nonsense mutation in *WAR1* in strain IMS0480, which encodes a transcriptional activator of *PDR12* (35) (see Table S1). Inactivation of either *PDR12* or *WAR1* causes absence of Pdr12 from the plasma membrane (35). Pdr12 has been shown to export a wide range of monocarboxylic acids (C_3 to C_7) (33, 36). To investigate a possible role of the mutations in *PDR12* and/or *TPO1* in biotin prototrophy, *pdr12Δ*, *tpo1Δ*, and *pdr12Δ tpo1Δ* mutations were introduced in strains overexpressing *BIO1*. Deletion of *PDR12* or *TPO1* did not lead to biotin prototrophy in a strain with a single wild-type *BIO1* gene (Table 2). In contrast, deletion of either of these transporter genes greatly increased the specific growth rates of strains that overexpressed *BIO1* in biotin-free SMD, from 0.15 h^{-1} in a strain without transporter deletion to up to 0.25 h^{-1} in a *pdr12Δ* strain (Table 2). A combination of both deletions did not lead to a further increase of the specific growth rate (Table 2).

A possible explanation for the observed impact of mutations in *TPO1* and *PDR12* is that they prevent export of an essential intermediate in the biotin biosynthesis pathway by the encoded transporters. Pimelic acid, a C_7 -dicarboxylic acid, is the substrate for Bio1, which, based on the amplification of *BIO1* observed in evolved strains, may catalyze a rate-controlling reaction in biotin synthesis. For many organic acids, a role of Pdr12 in their export from *S. cerevisiae* cells has been inferred from a strongly increased sensitivity of *pdr12Δ* to the acid at pH values below its pK_a due to weak organic acid uncoupling (33, 36, 37). Pimelic acid supplementation of cultures grown at pH 4.5, which is below the pK_a values of pimelic acid ($pK_{a,1} = 4.71$; $pK_{a,2} = 5.58$), did not reveal increased sensitivity of *PDR12* and/or *TPO1* single- or double-deletion mutants (see Fig. S1 in the supplemental material). However, growth of the reference strain, CEN.PK113-

7D, at pH 4.5 was not inhibited by pimelic acid concentrations of up to 100 mM (data not shown), indicating that pimelic acid uptake rates were too low to cause weak organic acid uncoupling. The absence of increased sensitivity in the deletion mutants, therefore, neither supports nor excludes a possible role of Tpo1 and/or Pdr12 in pimelic acid export.

DISCUSSION

Although the genome of *S. cerevisiae* CEN.PK113-7D contains a full set of *BIO* genes (*BIO1*, *BIO2*, *BIO3*, *BIO4*, *BIO5*, and *BIO6*) (22), the specific growth rate of the strain in biotin-free synthetic medium with glucose was at least 30-fold lower than in cultures supplemented with this vitamin. Although data obtained with this typical laboratory strain (38) cannot be directly extrapolated to natural isolates, such very low growth rates may well be relevant for survival in natural environments where biotin is scarce. Independent laboratory evolution experiments with strain CEN.PK113-7D yielded four evolved strains, three of which grew equally fast in biotin-free medium and in biotin-supplemented cultures. Such complete biotin prototrophy is rare among natural biotin-prototrophic strains, whose growth on biotin-free medium has been reported to vary from weak to vigorous but typically is slower than in biotin-containing medium (10, 14, 16).

The mutations that were shown to contribute to full biotin prototrophy of the laboratory-evolved strains provide new insights into the genetic basis of the phenotype. Up to 40-fold amplification of the clustered *BIO1* and *BIO6* genes in the evolved strains was shown to reflect a key role of the copy number of *BIO1*, but not *BIO6*, in biotin prototrophy. Introduction of a multicopy vector carrying *BIO1* in a nonevolved strain enabled it to grow on biotin-free medium at a growth rate ca. 40% of that observed in the fastest-growing evolved strains. These results indicate that the pimeloyl-CoA synthetase Bio1 exerts a high degree of metabolic control over biotin biosynthesis in the nonevolved strain. Comparison of the predicted protein sequence of *BIO1* from strain CEN.PK113-7D did not identify amino acids that were not also found in *BIO1* genes of other *S. cerevisiae* strains, indicating that the requirement for *BIO1* amplification was unlikely to be due to a CEN.PK-specific, inferior *BIO1* allele. Three of the four evolved strains contained a duplication of ChrI, which carries the native copies of *BIO1* and *BIO6*, while additional copies of these genes were found on neochromosomes resulting from translocation events. The plasticity of the yeast genome under selective growth conditions is further illustrated in one of the evolved strains (IMS0478) by the additional presence of two copies of ChrIX, as well as of the left arm of ChrVIII. These results confirm that chromosomal rearrangements and copy number variation are key mechanisms for genetic adaptation in short-term laboratory evolution experiments (39, 40). The biotin-prototrophic sake strain of *S. cerevisiae* in which *BIO6* was first discovered also contains copies of *BIO6* on multiple chromosomes (16). This genotypic similarity indicates that the genetic adaptations that enable sake yeasts to grow at the very low biotin concentrations in sake mash (41) at least partially overlap those seen in the present laboratory evolution study.

Surprisingly, loss-of-function mutations in the membrane transporter genes *TPO1* and *PDR12*, as well as in *WAR1*, which encodes a positive regulator of *PDR12* (35, 42), had a strong positive effect on biotin prototrophy. Neither the polyamine transporter Tpo1 (34, 43) nor the monocarboxylate exporter Pdr12 (36) has previously been associated with biotin synthesis. Although in the case of Tpo1 direct mediation of monocarboxylic acid transport has not been demonstrated, both transporters have been implicated in the process, including, in the case of Pdr12, the transport of the C₇-monocarboxylate heptatonic acid (37). If Pdr12 and/or Tpo1 export the C₇-dicarboxylate pimelic acid, the precursor of biotin biosynthesis, the resulting decrease in the intracellular pimelate concentration could reduce the flux through the rate-controlling pimeloyl-CoA synthetase (Bio1) reaction. Alternatively, Pdr12 and/or Tpo1 might catalyze the export of other key intermediates of biotin synthesis, such as the

aminated compounds KAPA and DAPA. A mutation in one of the evolved strains in the KAPA transporter gene *BIO5* could also be consistent with this hypothesis.

In the case of Tpo1, an alternative explanation for its impact on biotin prototrophy is related to its role in spermidine homeostasis. Supplementation of this compound in a spermidine-deficient *S. cerevisiae* strain has been shown to cause an up to 14-fold upregulation of *BIO* genes (44). At a pH of 5, which was used in the present laboratory evolution, Tpo1 has been reported to primarily catalyze polyamine export (45). Moreover, inactivation of *TPO1* has been shown to lead to increased intracellular spermidine concentrations (46, 47). By enhancing the previously demonstrated induction of *BIO* genes upon biotin depletion (16, 48, 49), accumulation of polyamines could contribute to increased growth rates in biotin-free medium.

Elimination of vitamin requirements of *S. cerevisiae* could simplify the design and scaling up of fermentation processes and improve process economics. The demonstration that an *S. cerevisiae* strain that contains a basic complement of *BIO* genes can be evolved for complete biotin prototrophy opens up perspectives for the development of industrial *S. cerevisiae* strains that are completely prototrophic for this and, potentially, other vitamins. However, the extensive genomic rearrangements in the evolved strains complicate their direct use as metabolic-engineering platforms. Overexpression of *BIO1*, combined with deletion of *TPO1* or *PDR12*, was sufficient to reach specific growth rates in biotin-free medium that were only 40% lower than those observed in biotin-supplemented cultures. Null mutations in *TPO1* and *PDR12* had a similar effect on the specific growth rates of *BIO1*-overexpressing strains in biotin-free medium, but their effects were not additive (Table 2). While inactivation of *PDR12* strongly increases the sensitivity of *S. cerevisiae* to several apolar carboxylic acids (36), null mutations in *TPO1* have been reported to confer an increased tolerance for industrially relevant inhibitors, which in turn has been shown to result in higher productivities of industrial products (46, 50). Inactivation of *TPO1*, therefore, appears to be the preferred intervention in strategies for eliminating biotin requirements in industrial yeast strains.

A further systematic analysis of the other mutations in evolved biotin-prototrophic strains, combined with overexpression and/or codon optimization of *BIO1* and other *BIO* genes, might allow additional improvements of rationally engineered biotin-prototrophic *S. cerevisiae* strains. In addition, the fast-growing biotin-prototrophic strains described in this study provide interesting experimental platforms for unraveling the elusive biochemistry of pimelate biosynthesis in *S. cerevisiae* and other yeasts (10, 12, 13).

MATERIALS AND METHODS

Strains, media, and maintenance. The *S. cerevisiae* strains used and constructed in this study (Table 1) belong to the CEN.PK lineage (38), with the exception of *S. cerevisiae* S288C (38, 51). Yeast strains were grown on synthetic medium (SM) or YP medium (10 g · liter⁻¹ Bacto yeast extract, 20 g · liter⁻¹ Bacto peptone). Synthetic medium with urea as the nitrogen source (SM-urea) contained 38 mM urea and 38 mM K₂SO₄ instead of (NH₄)₂SO₄. After autoclaving SM at 121°C for 20 min or sterile filtration of SM-urea using 0.2- μ m bottle top filters (Thermo Scientific, Waltham, MA), synthetic media were supplemented with 1 ml · liter⁻¹ of a filter-sterilized vitamin solution [0.05 g · liter⁻¹ D-(+)-biotin, 1.0 g · liter⁻¹ D-calcium pantothenate, 1.0 g · liter⁻¹ nicotinic acid, 25 g · liter⁻¹ myo-inositol, 1.0 g · liter⁻¹ thiamine hydrochloride, 1.0 g · liter⁻¹ pyridoxol hydrochloride, 0.20 g · liter⁻¹ 4-aminobenzoic acid]. Biotin-free SM was prepared by omitting biotin from this solution. Unless specifically indicated, “SM” specifies synthetic medium with (NH₄)₂SO₄ as the nitrogen source, while synthetic medium with urea as the nitrogen source is abbreviated as “SM-urea.” After autoclaving concentrated glucose solutions at 110°C for 20 min, glucose was added to SM, SM-urea, and YP media to a final concentration of 20 g · liter⁻¹, yielding SMD, SMD-urea, and YPD, respectively. Shake flasks (500 ml) containing 100 ml medium, as well as 50 ml Cellreactor filter top tubes (Greiner Bio-One B.V., Alphen a/d Rijn, The Netherlands) containing 25 ml medium, were incubated at 30°C and 200 rpm in an Innova incubator (Brunswick Scientific, Edison, NJ). Solid media contained 1.5% Bacto agar and, when indicated, 200 mg · liter⁻¹ G418 or 200 mg · liter⁻¹ hygromycin. Selection and counterselection of the *amdSYM* cassette were performed as described previously (52). *E. coli* strains were grown in LB (10 g · liter⁻¹ Bacto tryptone, 5 g · liter⁻¹ Bacto yeast extract, 5 g · liter⁻¹ NaCl) supplemented with 100 mg · liter⁻¹ ampicillin. Yeast and *E. coli* cultures were stored at -80°C after addition of (30% [vol/vol]) glycerol to stationary-phase shake flask cultures.

Molecular biology techniques. PCR amplification of DNA fragments with Phusion Hot Start II high-fidelity polymerase (Thermo Scientific) and desalted or PAGE-purified oligonucleotide primers (Sigma-Aldrich, St. Louis, MO) was performed according to the manufacturers' instructions. DreamTaq

polymerase (Thermo Scientific) was used for diagnostic PCR. The oligonucleotide primers used in this study are listed in Table 4. Amplified DNA fragments were separated by electrophoresis on 1% (wt/vol) agarose gels (Thermo Scientific) in Tris-acetate-EDTA (TAE) buffer (Thermo Scientific) at 90 V for 35 min and purified with a GenElute PCR Clean-Up kit (Sigma-Aldrich). Plasmids were isolated from yeast cultures with a Zymoprep Yeast Plasmid Miniprep II kit (Zymo Research, Irvine, CA) and from *E. coli* with a Sigma GenElute Plasmid kit (Sigma-Aldrich). Yeast genomic DNA was isolated using a YeaStar Genomic DNA kit (Zymo Research) or with an SDS-lithium acetate (LiAc) protocol (53). Yeast strains were transformed by the lithium acetate method (54), and eight of the resulting colonies were restreaked three consecutive times on biotin-supplemented selective medium, followed by analytical PCR to verify their genotype. *E. coli* DH5 α was used for chemical transformation (55) or for electroporation. Electroporation was done in a 2-mm cuvette (1652086; Bio-Rad, Hercules, CA) using a Gene Pulser Xcell electroporation system (Bio-Rad). After isolation, plasmids were verified by restriction analysis and analytical PCR.

Plasmid construction. Promoter fragments of highly expressed yeast genes and promoterless *BIO* genes were PCR amplified from genomic DNA of *S. cerevisiae* CEN.PK113-7D. The amplified *BIO* gene sequences included 0.5-kb terminator sequences. The 3' and 5' primers for amplification of promoter and terminator fragments, respectively, contained 60-bp synthetic extensions designed for efficient *in vivo* assembly of DNA fragments (56). Promoters and coding regions were fused by fusion PCR (57) and subsequently assembled into pJET1.2/blunt vectors with a CloneJet PCR cloning kit (Thermo Scientific), resulting in the vector constructs pUD416 and pUD418 (Table 5). Yeast expression plasmids were assembled *in vivo* by amplifying promoter-gene cassettes from pUD416 and pUD418 and vector fragments amplified from p426GPD (58). When necessary, oligonucleotide tags were changed to enable *in vivo* assembly with vector fragments. This assembly yielded the p426GPD-based plasmids pUDE446, pUDE448, and pUDE450 (Table 5).

Strain construction. *S. cerevisiae* strains with increased copy numbers of endogenous *BIO* genes (IME327, IME329, IME331, and IME334) (Table 1) were constructed by transforming CEN.PK113-5D (*ura3*) with multicopy expression plasmids (pUDE446, pUDE448, pUDE450, and p426GPD [*URA3*]). Geneticin (G418) resistance cassettes, PCR amplified from pUG6 (59), were used to delete *TPO1* and *PDR12* in CEN.PK113-5D, resulting in strains IMK129 and IMK163, respectively. IMK129 was used to construct a *TPO1* and *PDR12* double-deletion strain by transformation with a hygromycin resistance cassette (*hphNT1*) amplified from pMEL12 (32), resulting in IMK773. Deletion strains were subsequently transformed with pUDE450 (*BIO1 URA3*) or with the empty reference vector p426GPD (*URA3*), resulting in IMZ694, IMZ695, IMZ701, IMZ702, IMZ704, and IMZ705 (Table 1).

Shake flask and plate growth experiments. Thawed aliquots of frozen stock cultures (1 ml) were inoculated in SMD shake flask cultures and incubated for 12 h. This starter culture was used to inoculate a second shake flask culture on SMD that, after another 12 h, was used to inoculate a third culture on SMD, at an initial optical density at 660 nm (OD_{660}) of 0.05, 0.1, or 0.2. For biotin-free growth studies, all three cultures were grown on SMD without biotin. The OD_{660} of the third culture was monitored with a Libra S11 spectrophotometer (Biochrom, Cambridge, United Kingdom). Specific growth rates were calculated from at least four time points in the exponential growth phase of each culture. Strain CEN.PK113-7D, which consistently failed to grow on biotin-free SMD in the third culture, was used as a negative control in all growth experiments. Cell numbers were estimated from calibration curves of OD_{660} versus cell counts in an Accuri flow cytometer (Becton Dickinson B.V., Breda, The Netherlands) generated with exponentially growing shake flask cultures of strain CEN.PK113-7D on SMD medium. For plate assays, precultures were grown on SMD medium. Spot assays on SMD agar (pH 4.5) containing either 50 μ M or 2 mM $MgSO_4$ were performed as described previously (60). SMD agar plates were supplemented with either 0.05, 0.15, 0.5, 1, 1.5, 2, or 3 mM pimelic acid; 6 or 15 mM spermidine; or 0.5 mM potassium sorbate (see Fig. S1 in the supplemental material). Liquid cultures of CEN.PK113-7D containing different concentrations of pimelic acid were prepared similarly to shake flask cultivations but were carried out in 50-ml Cellreactor filter top tubes with 25 ml of SMD-urea (pH 4.5) with an inoculation OD_{660} of 0.1. Filter-sterilized pimelic acid solution (1.25 M, pH 4.5) was added to duplicate cultures to a final concentration of 10, 12.5, 25, 50, 70, 80, 90, or 100 mM.

Laboratory evolution. Laboratory evolution of *S. cerevisiae* CEN.PK113-7D for biotin prototrophy was performed in accelerostats and in sequential bioreactor batch cultures. Accelerostat evolution was preceded by serial transfers in 3 parallel shake flask experiments on biotin-free SMD, with an initial OD_{660} of 0.05 after each transfer. After 15 transfers (in 54 days), a specific growth rate of ca. 0.1 h^{-1} was reached. Fifteen milliliters of each evolution culture was then used to inoculate separate 450-ml Multifors 2 parallel bioreactors (Infors Benelux, Doetinchem, The Netherlands) with a working volume of 100 ml. These bioreactors were subsequently operated as accelerostats, which are continuous cultures in which the dilution rate is increased over time (27). During the initial batch phase, cells were grown on SM without biotin, supplemented with $20 \text{ g} \cdot \text{liter}^{-1}$ glucose and $0.3 \text{ g} \cdot \text{liter}^{-1}$ antifoam Pluronic PE 6100 (BASF, Ludwigshafen, Germany). When a decrease in CO_2 production indicated glucose depletion (CO_2 sensor; Bluesens, Herten, Germany), continuous cultivation was initiated at a dilution rate of 0.10 h^{-1} on SM without biotin, $7.5 \text{ g} \cdot \text{liter}^{-1}$ glucose, and $0.15 \text{ g} \cdot \text{liter}^{-1}$ antifoam Pluronic PE 6100. Cultures were grown at 30°C , while a culture pH of 5 was maintained by automated addition of 2 M KOH. The cultures were sparged with air at a flow rate of $50 \text{ ml} \cdot \text{min}^{-1}$ and stirred at 1,200 rpm. Dissolved oxygen concentrations remained above 40% of air saturation throughout the experiments. The dilution rate of the accelerostats was controlled by Iris Parallel Bioprocess Control software (Infors Benelux) based on a manually set threshold for the ratio between the CO_2 concentration in the outlet gas and the feed rate of the medium supply pump. If this ratio remained above the set point for at least 4 h, the medium feed rate was increased by 5%. When it remained below the set point for the same period, the feed rate was

TABLE 4 Primers used in this study

Product	Primer	Sequence (5' to 3')	
Construction of plasmids pUD416 and pUD418 <i>pPYK1</i> promoter fragment with TagB	8907	CACCTTTCGAGAGGACGATGCCCGTGTCTAAATGATTTCGACCAGCCTAAGAATGTTCAAC ACCTCGGATCGTCGGTTGTG	
	7428	TGTGATGATGTTTTATTGTTTTGATTGG	
	<i>pPGK1</i> promoter fragment with TagA	8908	ACTATATGTGAAGGCATGGCTATGGCACGGCAGACATTCCGCCAGATCATCAATAGGCAC ACTGTAATTGCTTTAGTTGTGATTTTTAG
		5917	TGTTTTATATTTGTTGTA AAAAAGTAGATAATTACTTCC
	<i>BIO1</i> + <i>tBIO1</i>	8915	CCAATCAAACAATAAAAACATCATCACAATGAACCAAAAATCACTCGACTTTTTATG
		8914	GTGCCTATTGATGATCTGGCGGAATGTCTGCCGTGCCATAGCCATGCCTTCACATATAGTTT TACTCTTTCTTTACCTTTTTTTCTTTAC
	<i>BIO6</i> + <i>tBIO6</i>	8916	GGAAGTAATTATCTACTTTTTACAACAAATATAAAAACAAATGTGTGAACATCAATTAACCCAAG
		7467	TTACAATATAGTGATAATCGTGGACTAGAGCAAGATTTCAAATAAGTAACAGCAGCAAATA TTACTCTCTAAACTGAGCACAAGTTTC
	Fusion of TagA- <i>pPGK1</i> + <i>BIO6</i> - <i>sga1</i> flank	3847	ACTATATGTGAAGGCATGGCTATGG
	Fusion of TagB- <i>pPYK1</i> + <i>BIO1</i> -TagA	4187	TTACAATATAGTGATAATCGTGGACTAGAG
4691		CACCTTTCGAGAGGACGATG	
3275		GTAAGGCGGTCTAGTAGTTATCCGTG	
Construction of plasmids pUDE446 to pUD450 TagI- <i>BIO6</i> -TagA fragment	9367	TATTCACGTAGACGGATAGGTATAGCCAGACATCAGCAGCATACTTCGGGAACCGTAGGC TATTACTCTCTAAACTGAGCACAAGTTTC	
	3847	ACTATATGTGAAGGCATGGCTATGG	
	TagA- <i>BIO1</i> -TagB fragment	4691	CACCTTTCGAGAGGACGATG
		3275	GTGCCTATTGATGATCTGGCGGAATG
	TagB-pMBP1-Amp-2u- <i>URA3</i> -TagI fragment	9369	GTTGAACATTCTAGGCTGGTCTGAATCATTTAGACACGGGCATCGCTCTCGAAAGGTGC GCGCTTGGCGTAATCATGGTC
		9366	GCCTACGGTCCCAGATGCTGCTGATGTCTGGCTATACCTATCCGTCTACGTGAATAC GGTACCCAATTCGCCCTATAGTG
	TagI- <i>BIO6</i> -TagA fragment	9367	TATTCACGTAGACGGATAGGTATAGCCAGACATCAGCAGCATACTTCGGGAACCGTAGGC TATTACTCTCTAAACTGAGCACAAGTTTC
		3847	ACTATATGTGAAGGCATGGCTATGG
	TagA-pMBP1-Amp-2u- <i>URA3</i> -TagI fragment	9368	GTGCCTATTGATGATCTGGCGGAATGCTGCCGTGCCATAGCCATGCCTTCACATATAGTC GCGCTTGGCGTAATCATGGTC
		9366	GCCTACGGTCCCAGATGCTGCTGATGTCTGGCTATACCTATCCGTCTACGTGAATAC GGTACCCAATTCGCCCTATAGTG
	TagA- <i>BIO1</i> -TagB fragment	4691	CACCTTTCGAGAGGACGATG
		3275	GTGCCTATTGATGATCTGGCGGAATG
	TagB-pMB1-Amp-2u- <i>URA3</i> -TagA fragment	9370	ACTATATGTGAAGGCATGGCTATGGCACGGCAGACATTCCGCCAGATCATCAATAGGCAC CGGTACCCAATTCGCCCTATAGTG
		9369	GTTGAACATTCTAGGCTGGTCTGAATCATTTAGACACGGGCATCGCTCTCGAAAGGTGC GCGCTTGGCGTAATCATGGTC
	Southern blot probe Amplification of probe for Southern blotting (<i>BIO1</i>)	2594	GCTAGGGTTCGCAATATGTCCTGG
		2595	CCACCACCTCATAAAGTTTACTGG
	Knockout fragments KanMX with <i>TPO1</i> overhangs for <i>tpo1:kanMX</i>	523	CAACTGCTACGGAGGGCAATGGTGGTGCAGATTTAGCGATTCAAAGAACGCGCGCTAAGA CAATTCATCACAGCTGAAGCTTCGTACGC
		524	CCTCATGAAAGTGTGCTGCGACGGCAGAAGCTGCCAACAATAGATACGCTTCAGTGCC TACGATGAGTGCATAGGCCACTAGTGGATCTG
KanMX with <i>PDR12</i> overhangs for <i>pdr12:kanMX</i>		3582	TCCCAGTTACTAATTTTCACTTAAAAAAGGTTTACAGATTTATTGTTATTGTTCTTATCAG CTGAAGCTTCGTACGC
		3583	AAAATTTGTGAAAAAATTGAAAAAATAAATTTGTGTGTTAAACCACGAAATACAAATATG CATAGGCCACTAGTGGATCTG
Hygromycin cassette with <i>PDR12</i> overhangs for <i>pdr12:hph</i>		10447	TAATTTTCACTTAAAAAAGGTTTACAGATTTATTGTTATTGTTCTTATTAATAAAAAATAG GTCTAGAGATCTGTTTAGC
		10448	AAAATTTAAAAAATAAATTTGTGTGTTAAACCACGAAATACAAATATATTTGCTTGCTTGT CGAGAGCTCGTTAAAGCCTTC
qPCR primers <i>BIO1</i> qPCR	8250	CCTTTACCATGCCGCAAGTG	
	8251	AAGGTCTCCAGTGGCATGTC	
	<i>BIO2</i> qPCR	8383	GTCTCGGTGAAAGCGAAGAC
		8384	CAGCCATTGGAGTCCCTTTG

(Continued on next page)

TABLE 4 (Continued)

Product	Primer	Sequence (5' to 3')
<i>BIO3</i> qPCR	8254	GCATCAGTCCCTCCGATCAG
	8255	GCCACCAGTAGGGCTATTTG
<i>BIO4</i> qPCR	8318	AGAGTGGAGCGCAGAGAATC
	8319	TGGCCGCTAGTCTCAATCAG
<i>BIO6</i> qPCR	8320	TTGACGGCCGGATATTTGAC
	8321	AGGTTTGTCCGTGCATGAAG
<i>ACT1</i> qPCR	313	GGCTTCTTGACTACCTTCCA
	314	AGAAACACTTGTGGTGAACGA

decreased by 4.5%. This setup ensured a steady increase in the dilution rate as the culture evolved to reach higher specific growth rates while preventing culture washout. During evolution experiments, the threshold ratio of CO₂ output and feed rate was manually adjusted to compensate for changes in growth stoichiometry caused by a reduced relative contribution of maintenance energy metabolism at higher specific growth rates (61). Accelerostat cultures were terminated when, within 3 months of accelerostat selection, dilution rates of 0.24 to 0.28 h⁻¹ were reached.

Laboratory evolution in sequential batch reactors was preceded by shake flask cultivation of strain CEN.PK113-7D in biotin-free SMD, using a frozen stock culture as the inoculum. After 2 days, 0.1 ml of this culture was transferred to a fresh culture to deplete biotin stores and to generate a preculture from which, after ca. 12 h of incubation, a bioreactor culture was inoculated at an initial OD₆₆₀ of 0.05. Sequential batch cultivation was performed in 450-ml Multifors 2 parallel bioreactors (Infors Benelux) with a working volume of 100 ml. Aeration, pH, temperature, and dissolved oxygen concentration thresholds were the same as in the accelerostat cultures. Growth was monitored based on the CO₂ concentration in the off gas. When, after first having reached the CO₂ production peak, the CO₂ percentage in the off gas decreased below 0.02%, a computer-controlled peristaltic pump automatically removed approximately 95% of the culture volume, leaving approximately 5% as an inoculum for the next batch. The experiment was stopped when, after 11 batch cultivation cycles (47 days), no further increase in the growth rate was observed over the following six consecutive batches and, moreover, cells with a multicellular clumping phenotype were observed in the culture. Clumping phenotypes, which facilitate sedimentation during empty-refill cycles and thereby enable mutants to escape selection for faster growth in sequential batch reactors (29), were not observed in the accelerostat cultures. Single-colony isolates from accelerostats and sequential batch reactors were obtained by plating on biotin-free SMD. To facilitate analysis of single cell lines and subsequent genetic analysis, nonclumping single cell lines were selected from the sequential batch cultures by microscopic inspection of colonies after plating on biotin-free SMD.

qPCR experiments. qPCR experiments were performed with duplicate cultures pregrown on SMD with or without biotin. RNA extraction was performed following the method of Schmitt et al. (62), while the sampling procedure was done as described previously (63). cDNA was synthesized using a QuantiTect reverse transcription kit (Qiagen, Düsseldorf, Germany), and concentrations were determined using a Qubit fluorometer (Life Technologies). qPCR experiments with cDNA from duplicate cultures were performed in technical triplicates on three dilutions of each sample, using a QuantiTect SYBR green PCR kit (Qiagen) with a primer concentration of 0.5 μM in a total volume of 20 μl in the Rotor-Gene Q (Qiagen). The qPCR primers are listed in Table 4. *ACT1* expression levels determined from the same culture were used as an internal standard. Expression levels of *BIO* genes relative to those of *ACT1* were determined using the $\Delta\Delta C_T$ method (64). Briefly, normalized expression levels of the gene of interest (GOI) were calculated by subtracting the average C_T value obtained from technical triplicate measurements of the reference gene, *ACT1*, from the similarly averaged C_T values of the GOI ($\Delta C_{T\text{sample}} = \text{average } C_{T\text{GOI}\text{sample}} - \text{average } C_{T\text{ACT1}}$). The normalized expression level of the GOI was represented as $2^{-\Delta C_T}$. Data are represented as averages and standard errors of the mean (SEM) of expression levels calculated from independent duplicate cultures (Fig. 3; see Table S2 in the supplemental material).

CHEF electrophoresis and Southern blotting. Agarose plugs for all the strains were prepared using a contour-clamped homogeneous electric field (CHEF) genomic plug kit following the manufacturer's recommendations (Bio-Rad). One-third of each agarose plug was used per well of a 1% megabase agarose gel (Bio-Rad) buffered with 0.5× TBE (5.4 g Tris base, 2.75 g boric acid, 2 ml 0.5 M EDTA, pH 8, in 1 liter demineralized water). Chromosomes were separated in a CHEF-DR II system (Bio-Rad) for 28 h with a switch time of 60 s, an angle of 120°, and 5 V · cm⁻², followed by 16 h with a switch time of 90 s. DNA was stained with ethidium bromide (3 μg · ml⁻¹ in 0.5× TBE buffer) and destained in 0.5× TBE

TABLE 5 Plasmids used in this study

Name	Relevant characteristics	Reference
pUD416	<i>ampR</i> pJET1.2Blunt <i>TagB-pPYK-BIO1-tBIO1-TagA</i>	This study
pUD418	<i>ampR</i> pJET1.2Blunt <i>TagA-pPGK1-BIO6-tBIO6-5'Flank_{5GA1}</i>	This study
pUDE446	2μ URA3 <i>ampR</i> p426-GPD <i>pPYK-BIO1 pPGK1-BIO6</i>	This study
pUDE448	2μ URA3 <i>ampR</i> p426-GPD <i>pPGK1-BIO6</i>	This study
pUDE450	2μ URA3 <i>ampR</i> p426-GPD <i>pPYK-BIO1</i>	This study

buffer for 20 min with gentle agitation. Imaging was done using an InGenius LHR Gel Imaging System (Syngene, Bangalore, India). Southern blot probes (ca. 1 kb) were amplified from genomic DNA of CEN.PK113-7D and prepared with an AlkPhos direct-labeling and detection system (Amersham Biosciences, Piscataway, NJ) according to the manufacturer's protocol. Separated chromosomes were transferred to Hybond-N⁺ nylon membranes (GE Healthcare, Diegem, Belgium) using vacuum transfer with a vacuum blotter (Bio-Rad) and fixed to the nylon membrane by UV exposure for 2 min. Signal generation and detection were performed using an Amersham Gene Images AlkPhos direct-labeling and detection system, together with CDP-Star chemiluminescent detection (Amersham Biosciences) and exposure to an Amersham Hyperfilm ECL (Amersham Biosciences), following the manufacturer's recommendations.

DNA sequencing. Genomic DNA of strains IMS0478, IMS0480, IMS0481, and IMS0496 was isolated with a Qiagen Blood and Cell Culture DNA kit with 100/G genomic tips (Qiagen, Valencia, California) according to the manufacturer's protocol. Paired-end sequencing (126-bp reads) was performed on 350-bp insert libraries with an Illumina HiSeq 2500 sequencer (Baseclear BV, Leiden, The Netherlands) with a minimum sample size of 550 Mb, accounting for a coverage of approximately 45 times. Data mapping to the CEN.PK113-7D genome (22), data processing, and chromosome copy number variation determinations were done as described previously (65). Copy numbers of *BIO1*, *BIO2*, *BIO3*, *BIO4*, and *BIO6* were estimated by comparing their read depths to the average read depths of the single-copy reference genes [YAL001C (*TFC3*), YBL015W (*ACH1*), YCL040W (*GLK1*), YDL029W (*ARP2*), YEL012W (*UBC8*), YER049W (*TPA1*), YBR196C (*PGI1*), YER178W (*PDA1*), YFL039C (*ACT1*), and YJL121C (*RPE1*)], processed with Pilon (66).

Accession number(s). The sequencing data are available under the Bioproject accession number PRJNA383023.

SUPPLEMENTAL MATERIAL

Supplemental material for this article may be found at <https://doi.org/10.1128/AEM.00892-17>.

SUPPLEMENTAL FILE 1, PDF file, 0.5 MB.

ACKNOWLEDGMENTS

We thank Robert Mans for programming the accelerostats, Erwin Suir for construction of strains IMK129 and IMK163, Sophie van der Horst for assisting with evolutionary engineering, Wijn Dekker and Stéphanie O'Herne for help with CHEF electrophoresis and Southern blotting, and Maarten Verhoeven and Ioannis Papapetridis for fruitful discussions.

This work was supported by the BE-Basic R&D Program, which was granted an FES subsidy from the Dutch Ministry of Economic Affairs, Agriculture and Innovation (EL&I).

J.M.B., J.-M.G.D., A.J.A.V.M., and J.T.P. designed experiments. J.M.B. and J.T.P. wrote the text. J.M.B. and E.D.H. set up the accelerostats resulting in strains IMS0478, IMS0480, and IMS0481. J.M.B. performed the accelerostat selections, constructed all plasmids and yeast strains, characterized yeast strains, performed CHEF electrophoresis and Southern blotting, did spot plate assays, analyzed whole-genome sequencing data, identified and verified SNPs, made Magnolia plots, and determined gene copy numbers. C.C.K. performed qPCR experiments. E.D.H. carried out the SBR selection resulting in strain IMS0496. M.V.D.B. developed methods and wrote scripts for bioinformatics data analysis and interpretation and developed the Pilon-based method to determine gene copy numbers. We all read and approved the final manuscript.

REFERENCES

- Gailiuis J, Rinne RW, Benedict C. 1964. Pyruvate- oxaloacetate exchange reaction in baker's yeast. *Biochim Biophys Acta* 92:595–601.
- Losada M, Canovas J, Ruiz A. 1964. Oxaloacetate, citramalate and glutamate formation from pyruvate in baker's yeast. *Biochem Z* 340:60–74.
- Wakil SJ, Titchener EB, Gibson DM. 1958. Evidence for the participation of biotin in the enzymic synthesis of fatty acids. *Biochim Biophys Acta* 29:225–226. [https://doi.org/10.1016/0006-3002\(58\)90177-X](https://doi.org/10.1016/0006-3002(58)90177-X).
- Sumrada RA, Cooper TG. 1982. Urea carboxylase and allophanate hydrolase are components of a multifunctional protein in yeast. *J Biol Chem* 257:9119–9127.
- Kim HS, Hoja U, Stolz J, Sauer G, Schweizer E. 2004. Identification of the tRNA-binding protein Arc1p as a novel target of *in vivo* biotinylation in *Saccharomyces cerevisiae*. *J Biol Chem* 279:42445–42452. <https://doi.org/10.1074/jbc.M407137200>.
- Hoja U, Wellein C, Greiner E, Schweizer E. 1998. Pleiotropic phenotype of acetyl-CoA-carboxylase-defective yeast cells. *Eur J Biochem* 254: 520–526. <https://doi.org/10.1046/j.1432-1327.1998.2540520.x>.
- Streit W, Entcheva P. 2003. Biotin in microbes, the genes involved in its biosynthesis, its biochemical role and perspectives for biotechnological production. *Appl Microbiol Biotechnol* 61:21–31. <https://doi.org/10.1007/s00253-002-1186-2>.
- Lin S, Hanson RE, Cronan JE. 2010. Biotin synthesis begins by hijacking the fatty acid synthetic pathway. *Nat Chem Biol* 6:682–688. <https://doi.org/10.1038/nchembio.420>.
- Kashiwagi K, Igarashi K. 2011. Identification and assays of polyamine transport systems in *Escherichia coli* and *Saccharomyces cerevisiae*. *Methods Mol Biol* 720:295–308. https://doi.org/10.1007/978-1-61779-034-8_18.
- Lin S, Cronan JE. 2011. Closing in on complete pathways of biotin biosynthesis. *Mol Biosyst* 7:1811–1821. <https://doi.org/10.1039/c1mb05022b>.
- Burkholder PR, McVeigh I, Moyer D. 1944. Studies on some growth factors of yeasts. *J Bacteriol* 48:385.
- Tanabe Y, Maruyama J-I, Yamaoka S, Yahagi D, Matsuo I, Tsutsumi N, Kitamoto K. 2011. Peroxisomes are involved in biotin biosynthesis in

- Aspergillus* and *Arabidopsis*. *J Biol Chem* 286:30455–30461. <https://doi.org/10.1074/jbc.M111.247338>.
13. Magliano P, Flipphi M, Arpat BA, Delessert S, Poirier Y. 2011. Contributions of the peroxisome and β -oxidation cycle to biotin synthesis in fungi. *J Biol Chem* 286:42133–42140. <https://doi.org/10.1074/jbc.M111.279687>.
 14. Hall C, Dietrich FS. 2007. The reacquisition of biotin prototrophy in *Saccharomyces cerevisiae* involved horizontal gene transfer, gene duplication and gene clustering. *Genetics* 177:2293–2307. <https://doi.org/10.1534/genetics.107.074963>.
 15. Hall C, Brachat S, Dietrich FS. 2005. Contribution of horizontal gene transfer to the evolution of *Saccharomyces cerevisiae*. *Eukaryot Cell* 4:1102–1115. <https://doi.org/10.1128/EC.4.6.1102-1115.2005>.
 16. Wu H, Ito K, Shimoi H. 2005. Identification and characterization of a novel biotin biosynthesis gene in *Saccharomyces cerevisiae*. *Appl Environ Microbiol* 71:6845–6855. <https://doi.org/10.1128/AEM.71.11.6845-6855.2005>.
 17. Helliwell KE, Wheeler GL, Smith AG. 2013. Widespread decay of vitamin-related pathways: coincidence or consequence? *Trends Genet* 29:469–478. <https://doi.org/10.1016/j.tig.2013.03.003>.
 18. Azhar A, Booker GW, Polyak SW. 2015. Mechanisms of biotin transport. *Biochem Anal Biochem* 4:1.
 19. Stolz J, Hoja U, Meier S, Sauer N, Schweizer E. 1999. Identification of the plasma membrane H⁺-biotin symporter of *Saccharomyces cerevisiae* by rescue of a fatty acid-auxotrophic mutant. *J Biol Chem* 274:18741–18746. <https://doi.org/10.1074/jbc.274.26.18741>.
 20. Phalip V, Kuhn I, Lemoine Y, Jeltsch J-M. 1999. Characterization of the biotin biosynthesis pathway in *Saccharomyces cerevisiae* and evidence for a cluster containing *BIO5*, a novel gene involved in vitamer uptake. *Gene* 232:43–51. [https://doi.org/10.1016/S0378-1119\(99\)00117-1](https://doi.org/10.1016/S0378-1119(99)00117-1).
 21. Gasser B, Dragosits M, Mattanovich D. 2010. Engineering of biotin-prototrophy in *Pichia pastoris* for robust production processes. *Metab Eng* 12:573–580. <https://doi.org/10.1016/j.ymben.2010.07.002>.
 22. Nijkamp JF, van den Broek M, Datema E, de Kok S, Bosman L, Luttik MA, Daran-Lapujade P, Vongsangnak W, Nielsen J, Heijne WH. 2012. *De novo* sequencing, assembly and analysis of the genome of the laboratory strain *Saccharomyces cerevisiae* CEN. PK113-7D, a model for modern industrial biotechnology. *Microb Cell Fact* 11:36. <https://doi.org/10.1186/1475-2859-11-36>.
 23. Yang Y, Lang N, Yang G, Yang S, Jiang W, Gu Y. 2016. Improving the performance of solventogenic clostridia by reinforcing the biotin synthetic pathway. *Metab Eng* 35:121–128. <https://doi.org/10.1016/j.ymben.2016.02.006>.
 24. Piper MD, Daran-Lapujade P, Bro C, Regenber B, Knudsen S, Nielsen J, Pronk JT. 2002. Reproducibility of oligonucleotide microarray transcriptome analyses; an interlaboratory comparison using chemostat cultures of *Saccharomyces cerevisiae*. *J Biol Chem* 277:37001–37008. <https://doi.org/10.1074/jbc.M204490200>.
 25. Canelas AB, Harrison N, Fazio A, Zhang J, Pitkänen J-P, Van den Brink J, Bakker BM, Bogner L, Bouwman J, Castrillo JI. 2010. Integrated multi-laboratory systems biology reveals differences in protein metabolism between two reference yeast strains. *Nat Commun* 1:145. <https://doi.org/10.1038/ncomms1150>.
 26. Daran-Lapujade P, Rossell S, van Gulik WM, Luttik MA, de Groot MJ, Slijper M, Heck AJ, Daran J-M, de Winde JH, Westerhoff HV. 2007. The fluxes through glycolytic enzymes in *Saccharomyces cerevisiae* are predominantly regulated at posttranscriptional levels. *Proc Natl Acad Sci U S A* 104:15753–15758. <https://doi.org/10.1073/pnas.0707476104>.
 27. Paalme T, Kahru A, Elken R, Vanatalu K, Tiisma K, Raivo V. 1995. The computer-controlled continuous culture of *Escherichia coli* with smooth change of dilution rate (A-stat). *J Microbiol Methods* 24:145–153. [https://doi.org/10.1016/0167-7012\(95\)00064-X](https://doi.org/10.1016/0167-7012(95)00064-X).
 28. Kuyper M, Toirkens MJ, Diderich JA, Winkler AA, Dijken JP, Pronk JT. 2005. Evolutionary engineering of mixed-sugar utilization by a xylose-fermenting *Saccharomyces cerevisiae* strain. *FEMS Yeast Res* 5:925–934. <https://doi.org/10.1016/j.femsyr.2005.04.004>.
 29. Oud B, Guadalupe-Medina V, Nijkamp JF, de Ridder D, Pronk JT, van Maris AJ, Daran J-M. 2013. Genome duplication and mutations in *ACE2* cause multicellular, fast-sedimenting phenotypes in evolved *Saccharomyces cerevisiae*. *Proc Natl Acad Sci U S A* 110:E4223–E4231. <https://doi.org/10.1073/pnas.1305949110>.
 30. Kuyper M, Hartog MM, Toirkens MJ, Almering MJ, Winkler AA, Dijken JP, Pronk JT. 2005. Metabolic engineering of a xylose-isomerase-expressing *Saccharomyces cerevisiae* strain for rapid anaerobic xylose fermentation. *FEMS Yeast Res* 5:399–409. <https://doi.org/10.1016/j.femsyr.2004.09.010>.
 31. Pronk JT. 2002. Auxotrophic yeast strains in fundamental and applied research. *Appl Environ Microbiol* 68:2095–2100. <https://doi.org/10.1128/AEM.68.5.2095-2100.2002>.
 32. Mans R, van Rossum HM, Wijsman M, Backx A, Kuijpers NG, van den Broek M, Daran-Lapujade P, Pronk JT, van Maris AJ, Daran J-MG. 2015. CRISPR/Cas9: a molecular Swiss army knife for simultaneous introduction of multiple genetic modifications in *Saccharomyces cerevisiae*. *FEMS Yeast Res* 15:fov004. <https://doi.org/10.1093/femsyr/fov004>.
 33. Hazelwood LA, Tai SL, Boer VM, De Winde JH, Pronk JT, Daran JM. 2006. A new physiological role for Pdr12p in *Saccharomyces cerevisiae*: export of aromatic and branched-chain organic acids produced in amino acid catabolism. *FEMS Yeast Res* 6:937–945. <https://doi.org/10.1111/j.1567-1364.2006.00094.x>.
 34. Albertsen M, Bellahn I, Krämer R, Waffenschmidt S. 2003. Localization and function of the yeast multidrug transporter Tpo1p. *J Biol Chem* 278:12820–12825. <https://doi.org/10.1074/jbc.M210715200>.
 35. Kren A, Mamnun YM, Bauer BE, Schüller C, Wolfger H, Hatzixanthis K, Mollapour M, Gregori C, Piper P, Kuchler K. 2003. War1p, a novel transcription factor controlling weak acid stress response in yeast. *Mol Cell Biol* 23:1775–1785. <https://doi.org/10.1128/MCB.23.5.1775-1785.2003>.
 36. Piper P, Mahé Y, Thompson S, Pandjaitan R, Holyoak C, Egnér R, Mühlbauer M, Coote P, Kuchler K. 1998. The Pdr12 ABC transporter is required for the development of weak organic acid resistance in yeast. *EMBO J* 17:4257–4265. <https://doi.org/10.1093/emboj/17.15.4257>.
 37. Holyoak CD, Bracey D, Piper PW, Kuchler K, Coote PJ. 1999. The *Saccharomyces cerevisiae* weak-acid-inducible ABC transporter Pdr12 transports fluorescein and preservative anions from the cytosol by an energy-dependent mechanism. *J Bacteriol* 181:4644–4652.
 38. Entian K-D, Kötter P. 2007. 25 yeast genetic strain and plasmid collections. *Methods Microbiol* 36:629–666. [https://doi.org/10.1016/S0580-9517\(06\)36025-4](https://doi.org/10.1016/S0580-9517(06)36025-4).
 39. Wolfe KH, Shields DC. 1997. Molecular evidence for an ancient duplication of the entire yeast genome. *Nature* 387:708–712. <https://doi.org/10.1038/42711>.
 40. de Kok S, Nijkamp JF, Oud B, Roque FC, Ridder D, Daran JM, Pronk JT, Maris AJ. 2012. Laboratory evolution of new lactate transporter genes in a *ΔJEN1* mutant of *Saccharomyces cerevisiae* and their identification as *ADY2* alleles by whole-genome resequencing and transcriptome analysis. *FEMS Yeast Res* 12:359–374. <https://doi.org/10.1111/j.1567-1364.2011.00787.x>.
 41. Torigata K, Akiyama Y. 1968. Tests of sake brewing by yeasts after cultured with ventilation. 1. Rising and falling of vitamins contained in sake moromi and preservative tests of yeasts. *J Brew Soc Japan* 63:60–63.
 42. Schüller C, Mamnun YM, Mollapour M, Krapf G, Schuster M, Bauer BE, Piper PW, Kuchler K. 2004. Global phenotypic analysis and transcriptional profiling defines the weak acid stress response regulon in *Saccharomyces cerevisiae*. *Mol Biol Cell* 15:706–720.
 43. Tomitori H, Kashiwagi K, Sakata K, Kakinuma Y, Igarashi K. 1999. Identification of a gene for a polyamine transport protein in yeast. *J Biol Chem* 274:3265–3267. <https://doi.org/10.1074/jbc.274.6.3265>.
 44. Chattopadhyay MK, Chen W, Poy G, Cam M, Stiles D, Tabor H. 2009. Microarray studies on the genes responsive to the addition of spermidine or spermine to a *Saccharomyces cerevisiae* spermidine synthase mutant. *Yeast* 26:531–544. <https://doi.org/10.1002/yea.1703>.
 45. Uemura T, Tachihara K, Tomitori H, Kashiwagi K, Igarashi K. 2005. Characteristics of the polyamine transporter *TPO1* and regulation of its activity and cellular localization by phosphorylation. *J Biol Chem* 280:9646–9652. <https://doi.org/10.1074/jbc.M410274200>.
 46. Kim SK, Jin YS, Choi IG, Park YC, Seo JH. 2015. Enhanced tolerance of *Saccharomyces cerevisiae* to multiple lignocellulose-derived inhibitors through modulation of spermidine contents. *Metab Eng* 29:46–55. <https://doi.org/10.1016/j.ymben.2015.02.004>.
 47. Krüger A, Vowinckel J, Mülleder M, Grote P, Capuano F, Bluemlein K, Ralser M. 2013. Tpo1-mediated spermine and spermidine export controls cell cycle delay and times antioxidant protein expression during the oxidative stress response. *EMBO rep* 14:1113–1119. <https://doi.org/10.1038/embor.2013.165>.
 48. Wodicka L, Dong H, Mittmann M, Ho M-H, Lockhart DJ. 1997. Genome-wide expression monitoring in *Saccharomyces cerevisiae*. *Nat Biotechnol* 15:1359–1367. <https://doi.org/10.1038/nbt1297-1359>.

49. Madsen CT, Sylvestersen KB, Young C, Larsen SC, Poulsen JW, Andersen MA, Palmqvist EA, Hey-Mogensen M, Jensen PB, Treebak JT. 2015. Biotin starvation causes mitochondrial protein hyperacetylation and partial rescue by the SIRT3-like deacetylase Hst4p. *Nat Commun* 6:7726. <https://doi.org/10.1038/ncomms8726>.
50. Kim SK, Jo JH, Jin YS, Seo JH. 2017. Enhanced ethanol fermentation by engineered *Saccharomyces cerevisiae* strains with high spermidine contents. *Bioprocess Biosyst Eng* 40:683–691. <https://doi.org/10.1007/s00449-016-1733-3>.
51. Mortimer RK, Johnston JR. 1986. Genealogy of principal strains of the yeast genetic stock center. *Genetics* 113:35–43.
52. Solis-Escalante D, Kuijpers NG, Bongaerts N, Bolat I, Bosman L, Pronk JT, Daran JM, Daran-Lapujade P. 2013. *amdSYM*, a new dominant recyclable marker cassette for *Saccharomyces cerevisiae*. *FEMS Yeast Res* 13:126–139. <https://doi.org/10.1111/1567-1364.12024>.
53. Lööke M, Kristjuhan K, Kristjuhan A. 2011. Extraction of genomic DNA from yeasts for PCR-based applications. *Biotechniques* 50:325.
54. Gietz RD, Woods RA. 2002. Transformation of yeast by lithium acetate/single-stranded carrier DNA/polyethylene glycol method. *Methods Enzymol* 350:87–96. [https://doi.org/10.1016/S0076-6879\(02\)50957-5](https://doi.org/10.1016/S0076-6879(02)50957-5).
55. Inoue H, Nojima H, Okayama H. 1990. High efficiency transformation of *Escherichia coli* with plasmids. *Gene* 96:23–28. [https://doi.org/10.1016/0378-1119\(90\)90336-P](https://doi.org/10.1016/0378-1119(90)90336-P).
56. Kuijpers N, Solis-Escalante D, Bosman L, van den Broek M, Pronk JT, Daran J-M, Daran-Lapujade P. 2013. A versatile, efficient strategy for assembly of multi-fragment expression vectors in *Saccharomyces cerevisiae* using 60 bp synthetic recombination sequences. *Microb Cell Fact* 12:47. <https://doi.org/10.1186/1475-2859-12-47>.
57. Shevchuk NA, Bryksin AV, Nusinovich YA, Cabello FC, Sutherland M, Ladisch S. 2004. Construction of long DNA molecules using long PCR-based fusion of several fragments simultaneously. *Nucleic Acids Res* 32:e19–e19. <https://doi.org/10.1093/nar/gnh014>.
58. Mumberg D, Müller R, Funk M. 1995. Yeast vectors for the controlled expression of heterologous proteins in different genetic backgrounds. *Gene* 156:119–122. [https://doi.org/10.1016/0378-1119\(95\)00037-7](https://doi.org/10.1016/0378-1119(95)00037-7).
59. Güldener U, Heck S, Fiedler T, Beinhauer J, Hegemann JH. 1996. A new efficient gene disruption cassette for repeated use in budding yeast. *Nucleic Acids Res* 24:2519–2524. <https://doi.org/10.1093/nar/24.13.2519>.
60. van Rossum HM, Kozak BU, Niemeijer MS, Dykstra JC, Luttk MA, Daran J-MG, van Maris AJ, Pronk JT. 2016. Requirements for carnitine shuttle-mediated translocation of mitochondrial acetyl moieties to the yeast cytosol. *mBio* 7:e00520–00516. <https://doi.org/10.1128/mBio.00520-16>.
61. Verduyn C, Postma E, Scheffers WA, Van Dijken JP. 1990. Energetics of *Saccharomyces cerevisiae* in anaerobic glucose-limited chemostat cultures. *Microbiology* 136:405–412.
62. Schmitt ME, Brown TA, Trumpower BL. 1990. A rapid and simple method for preparation of RNA from *Saccharomyces cerevisiae*. *Nucleic Acids Res* 18:3091. <https://doi.org/10.1093/nar/18.10.3091>.
63. Huisjes EH, Luttk MA, Almering MJ, Bisschops MM, Dang DH, Kleerebezem M, Siezen R, van Maris AJ, Pronk JT. 2012. Toward pectin fermentation by *Saccharomyces cerevisiae*: expression of the first two steps of a bacterial pathway for D-galacturonate metabolism. *J Biotechnol* 162:303–310. <https://doi.org/10.1016/j.jbiotec.2012.10.003>.
64. Schmittgen TD, Livak KJ. 2008. Analyzing real-time PCR data by the comparative CT method. *Nat Protoc* 3:1101–1108. <https://doi.org/10.1038/nprot.2008.73>.
65. Verhoeven MD, Lee M, Kamoen L, van den Broek M, Janssen DB, Daran J-MG, van Maris AJ, Pronk JT. 2017. Mutations in *PMR1* stimulate xylose isomerase activity and anaerobic growth on xylose of engineered *Saccharomyces cerevisiae* by influencing manganese homeostasis. *Sci Rep* 7:46155. <https://doi.org/10.1038/srep46155>.
66. Walker BJ, Abeel T, Shea T, Priest M, Abouelliel A, Sakthikumar S, Cuomo CA, Zeng Q, Wortman J, Young SK. 2014. Pilon: an integrated tool for comprehensive microbial variant detection and genome assembly improvement. *PLoS One* 9:e112963. <https://doi.org/10.1371/journal.pone.0112963>.
67. Nijkamp JF, van den Broek MA, Geertman J-MA, Reinders MJ, Daran J-MG, de Ridder D. 2012. *De novo* detection of copy number variation by co-assembly. *Bioinformatics* 28:3195–3202. <https://doi.org/10.1093/bioinformatics/bts601>.