

Reconstitution of highly purified saxitoxin-sensitive Na⁺-channels into planar lipid bilayers

Wolfgang Hanke, Günther Boheim, Jacques Barhanin¹, David Pauron¹ and Michel Lazdunski^{1*}

Department of Cell Physiology, Ruhr-Universität Bochum, Postfach 102148, D-4630 Bochum, FRG, and ¹Centre de Biochimie du CNRS, Faculté des Sciences, Parc Valrose, F-06034 Nice Cedex, France

*To whom reprint requests should be sent
Communicated by Michel Lazdunski

Highly purified Na⁺-channels isolated from rat brain have been reconstituted into virtually solvent-free planar lipid bilayer membranes. Two different types of electrically excitable channels were detected in the absence of any neurotoxins. The activity of both channels was blocked by saxitoxin. The first channel type is highly selective for Na⁺ over K⁺ (~10:1), it shows a bursting behavior, a conductance of 25 pS in Na⁺-Ringer and undergoes continuous opening and closing events for periods of minutes within a defined range of negative membranes voltages. The second channel type has a conductance of 150 pS and a lower selectivity for Na⁺ and K⁺ (2.2:1); only a few opening and closing events are observed with this channel after one voltage jump. The latter type of channel is also found with highly purified Na⁺-channel from *Electrophorus electricus* electroplax. A qualitative analysis of the physicochemical and pharmacological properties of the high conductance channel has been carried out. Channel properties are affected not only by saxitoxin but also by a scorpion (*Centruroides suffusus suffusus*) toxin and a sea anemone (*Anemonia sulcata*) toxin both known to be selective for the Na⁺-channel. The spontaneous transformation of the large conductance channel type into the small one has been considered; the two channel types may represent the expression of activity of different conformational states of the same protein.

Key words: lipid bilayers/Na⁺-channels/reconstitution/saxitoxin

Introduction

The rising phase of action potentials in most excitable systems is due to voltage-dependent Na⁺-channels. These channels have a rich pharmacology and they are blocked by toxins like tetrodotoxin or saxitoxin. These channels have been extensively studied using voltage-clamp techniques and, more recently, using patch-clamp techniques (Sigworth and Neher, 1980; Horn *et al.*, 1981; Fenwick *et al.*, 1982; Cachelin *et al.*, 1983).

Important progress has been made recently in the purification and biochemical characterization of the voltage-dependent Na⁺-channel from the electric organ of *Electrophorus* electroplax (Moore *et al.*, 1982; Miller *et al.*, 1983; Norman *et al.*, 1983), from rat brain (Hartshorne and Catterall, 1981; Barhanin *et al.*, 1983a) and from skeletal muscle (Barchi *et al.*, 1980). There is now general agreement that a large glycoprotein, mol. wt. 200 000–270 000, is implicated in the structure of Na⁺-channels from all three sources. This

large glycoprotein not only contains the site which recognizes both tetrodotoxin and saxitoxin (Moore *et al.*, 1982; Hartshorne and Catterall, 1981), but also contains the distinct site that recognizes scorpion neurotoxins (Norman *et al.*, 1983; Barhanin *et al.*, 1983a, 1983b).

A number of investigators have studied the reconstitution of Na⁺-channel-containing membranes or of unpurified tetrodotoxin-sensitive Na⁺-channels into liposomes (Goldin *et al.*, 1980; Villegas *et al.*, 1980). More recently, two reports have described the functional reconstitution of more purified Na⁺-channels from rat brain (Talvenheimo *et al.*, 1982) and rat sarcolemma (Tanaka *et al.*, 1983). Reconstitution in these cases was measured by ²²Na⁺ flux techniques which can only be used after a chemical activation of Na⁺-channels by alkaloid neurotoxins like batrachotoxin and veratridine.

Channel reconstitution in artificial planar bilayers has been successfully tried with different techniques and systems (Miller, 1978; Schindler and Quast, 1980; Boheim *et al.*, 1981, 1982; Wilmsen *et al.*, 1983). Very recently the incorporation of unpurified Na⁺-channels from rat brain synaptosomes into decane-containing bilayers was reported (Krueger *et al.*, 1983). These authors observed single channel current fluctuations but again only in the presence of batrachotoxin. Blockage of these Na⁺-channels was observed with saxitoxin.

The purpose of this paper is to report the first functional reconstitution (including pharmacological properties) of extensively purified Na⁺-channels protein into solvent-free planar bilayers.

Results

After formation of a stable lipid bilayer membrane on the hole in a teflon sandwich septum separating two aqueous compartments the vesicle preparation was added to the *cis* side. The concentration of added vesicles was adjusted so that, within 5–15 min, single channel current fluctuations appeared following adequate voltage-jumps. The single channel situation is generally stable for at least 30 min, i.e. no further fusion events were observed in these cases for this period of time.

Figure 1a shows the SDS-gel electrophoresis pattern of the Na⁺-channel preparations at different levels of purification. The crude membrane preparation (P₃) from rat brain contains a large variety of proteins; an extensive purification of the Na⁺-channel protein is obtained after wheat germ agglutinin (WGA) chromatography, and the sucrose gradient step leads to one main broad band of mol. wt. 270 000 which represents the Na⁺-channel protein. Figure 1b shows typical recordings indicating that the same type of channel is found after reconstitution of brain Na⁺-channel preparations of different levels of purification. In addition, Figure 1b shows that the reconstitution of the Na⁺-channel extensively purified from *E. electricus* electroplax also gives a Na⁺-channel of large conductance which is similar to the one observed with brain Na⁺-channel preparations.

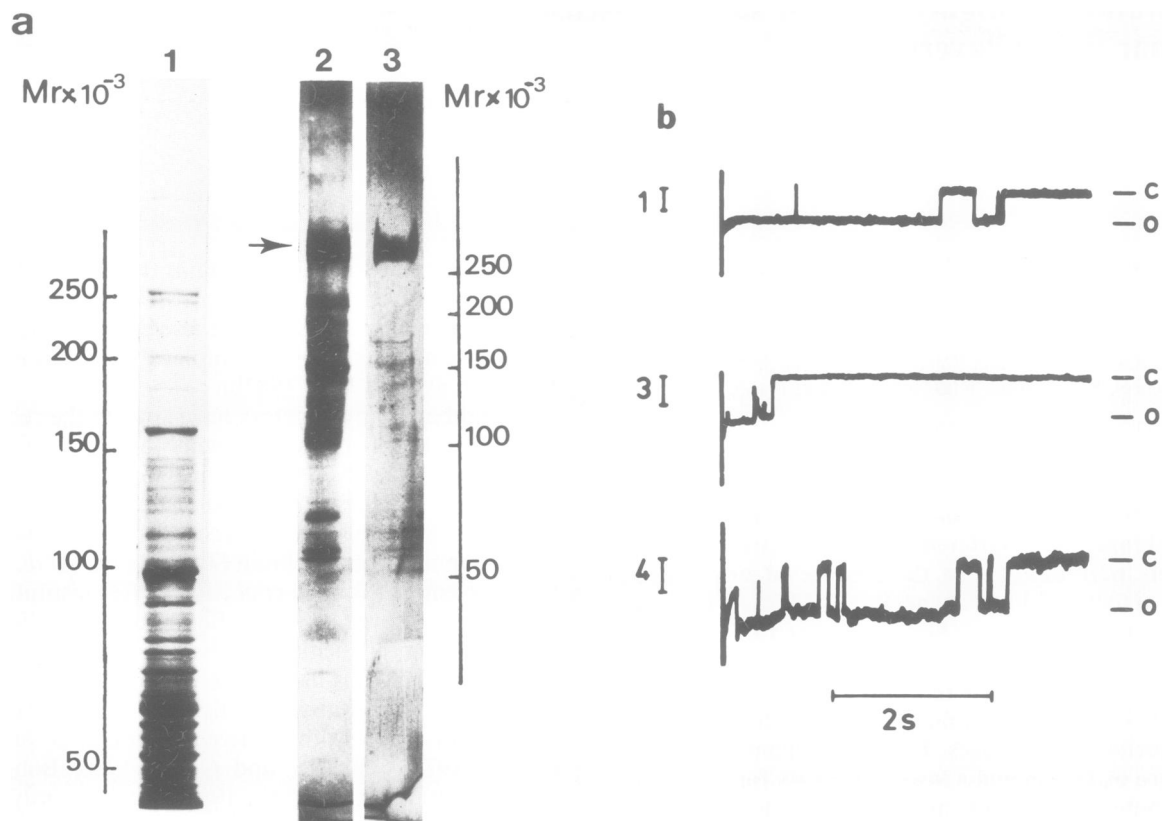

Fig. 1. (a) SDS-polyacrylamide gel electrophoresis of rat brain Na^+ -channel preparations prior to reconstitution. **Lane 1**, Coomassie blue staining of the membrane preparation (P_3) (running gel 4–12% polyacrylamide). **Lanes 2 and 3**, silver staining (running gel 4.5–15% polyacrylamide) of WGA (**lane 2**) and sucrose gradient purified preparation of rat brain ($7\text{--}14 \times 10^{-9}$ g of protein/ml) and sucrose gradient purified preparation of rat brain ($7\text{--}14 \times 10^{-9}$ g of protein/ml); **3**, sucrose gradient purified preparation of rat brain ($7\text{--}14 \times 10^{-9}$ g of protein/ml); **4**, extensively purified Na^+ -channel preparation from *Electrophorus* electroplax ($3\text{--}5 \times 10^{-9}$ g of protein/ml). 'o' and 'c' correspond to open and closed states of the channel respectively. The left side calibration bar indicates 100 pS. Experimental conditions: virtually solvent-free planar bilayers formed from a mixture of 1,2-SOPC/S-PE/cholesterol (20:75:5, molar ratio). Salt solution on both membrane sides (in mM): 140 NaCl, 3 KCl, 0.5 MgSO_4 , 0.5 CaCl_2 , 25 Hepes-Tris at pH 7.4. Temperature: 22–23°C. Voltage-jump from 0 mV. Applied voltages –50 mV (1), –65 mV (3), –75 mV (4).

Current fluctuations presented in Figure 2, and obtained with a Na^+ -channel preparation from rat brain, clearly show that two different types of stepwise current events can be distinguished. This is attributed to the presence of a channel of large conductance and of a channel of small conductance. Under conditions in which a Na^+ -Ringer solution (140 mM NaCl, 3 mM KCl, 0.5 mM MgSO_4 , 0.5 mM CaCl_2 , 25 mM Hepes-Tris at pH 7.4) is present on both membrane sides as in Figure 2, the conductance of the 'large' channel is $\Lambda_L = 150$ pS. This channel type appears immediately after the voltage jump and it disappears rapidly. During a continuous pulse series the 'large' channel fails to show up at random after ~25% of the voltage jumps. The 'small' channel has a conductance of $\Lambda_{S1} = 25$ pS and its properties will be analyzed in more detail below. Once observed this channel type may reappear for minutes at negative voltages. Both channel types adopt non-conducting states after jumps from negative to positive voltages as shown in the upper and middle traces of Figure 2. Although in most cases the small channel appears immediately after closure of the large one (see for example the control in Figure 5a), other situations occur which correspond to the spontaneous transformation of the channel type of large conductance into that of small conductance (Figure 2 middle and lower traces). In 1–2% of the closure events of the large channel, the conductance does not

return to the conductance level of the unmodified bilayer. Instead different states of conductance at $\Lambda_{S1} = 25$ pS (middle trace) or at $\Lambda_{S2} = 40$ pS (lower trace) are adopted. In the lower trace the 25 pS level is reached only after an intermediate transformation step to 40 pS. Conversely, a spontaneous re-transformation corresponding to a conductance change from $\Lambda_{S1} = 25$ pS to $\Lambda_L = 150$ pS was never observed.

The 'small' channel type has not been clearly identified in reconstitution experiments using the electric eel preparation because of increased current noise after reconstitution, probably due to the presence of small amounts of detergent (Lubrol PX for the electroplax preparation instead of Triton X-100 for the rat brain preparation). Consequently rat brain Na^+ -channel preparations have been used to characterize the two channel populations in more detail.

The small conductance channel

The Na^+ -channel with a small conductance shows a pronounced voltage dependence of channel state distributions. Figure 3a shows that the channel exhibits bursts of activity. Within a burst period the channel is open most of the time at –40 mV and closes at more negative voltages. The open state probability, P_o , changes from $P_o > 0.95$ at –40 mV to $P_o < 0.05$ at –80 mV with an equal distribution between the

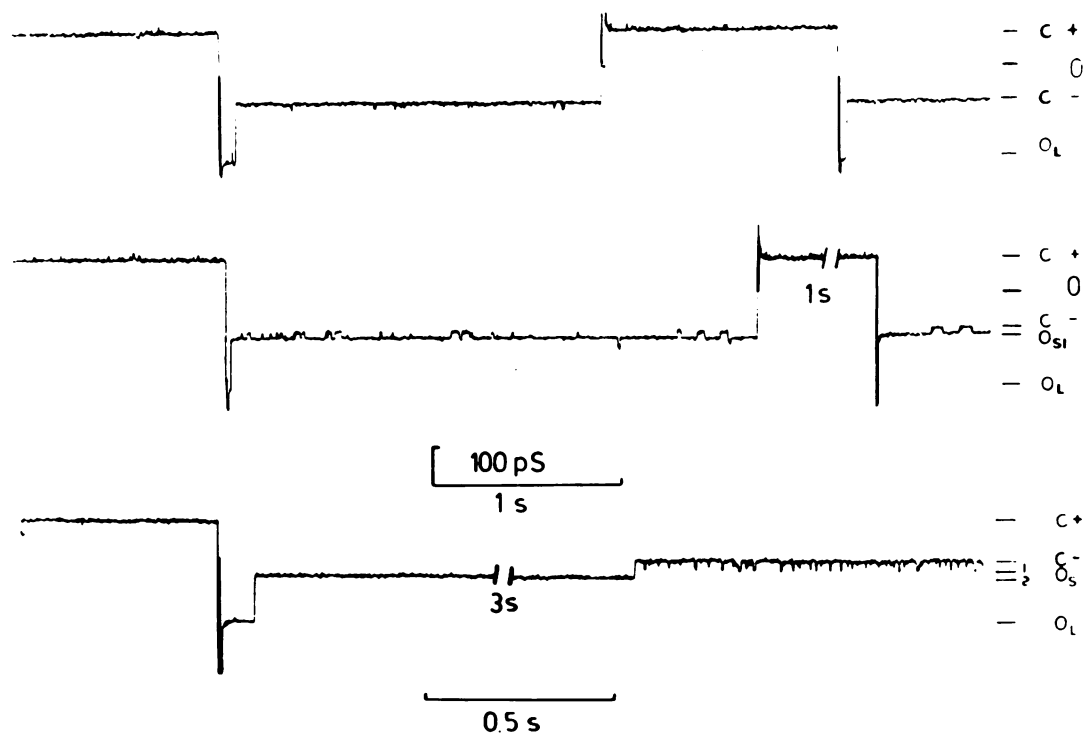

Fig. 2. Two upper traces, current fluctuations of two electrically distinguishable channels during a continuous series of voltage jumps between +75 mV and -75 mV. The upper trace shows the appearance of a channel of large conductance, $\Lambda_L = 150$ pS, but only when jumping from +75 to -75 mV. **Middle trace**, after the expression of the large conductance channel, a channel type of small conductance at $\Lambda_{S1} = 25$ pS is revealed. The small channel immediately appears with the closing of the large channel after the first jump from +75 to -75 mV. Both channels disappear after a new voltage jump from -75 to +75 mV. A third jump from +75 to -75 mV only reveals the small conductance channel type at 25 pS. **Lower trace**, this is another example for the spontaneous transformation of the large conductance channel type into the small one. While the middle trace shows a direct transition from the level O_L to the level O_{S1} , in the lower trace the transition to a long lasting conductance state (O_{S2}) of $\Lambda_{S2} = 40$ pS is observed before the small channel ($\Lambda_{S1} = 25$ pS) is created by another transition and starts to fluctuate (membrane voltage -75 mV). The Na⁺-channel preparation from rat brain ($3-6 \times 10^{-7}$ g protein/ml) used here corresponds to a purification up to the WGA step. Experimental conditions are the same as in Figure 1b.

open and closed states ($P_o = 0.5$) at about -60 mV. The single channel conductance ($\Lambda_{S1} = 25$ pS) is independent of voltage. As shown in the first trace in Figure 3a, the channel adopts the bursting mode for a period of minutes before it closes. In that respect current fluctuations of the Na⁺-channel resemble those observed for the Ca²⁺-dependent K⁺-channel (Methfessel and Boheim, 1982).

The ion selectivity of the channel was measured by using a K⁺-Ringer solution (composition as for a Na⁺-Ringer but with an exchange of Na⁺ and K⁺ concentrations). The single channel conductance in K⁺-Ringer was $\Lambda_{S,K^+} = 2-3$ pS, just at the limit of experimental resolution. Thus the ratio of channel conductances for Na⁺ and K⁺ is $\Lambda_{S,Na^+}:\Lambda_{S,K^+} \cong 10:1$.

Two conductance states of the small channel are in fact observed, Λ_{S1} which corresponds to 95-98% of the small channel activity and $\Lambda_{S2} = 40$ pS which corresponds to 2-5% of the small channel activity. Selected traces which show these two alternative conductance levels of the small and persistently fluctuating channel type are presented in Figure 3b. Since the different conductance values occur alternatively it seems likely that they originate from the same channel type.

The large conductance channel

This type of Na⁺-channel is easy to detect and very reproducible in its properties. A set of typical traces is shown in Figure 4 for different voltage jumps from 0 mV to the final value indicated. The mean lifetime of channel activity

becomes shorter at more negative membrane voltages. No channel openings were observed for voltage jumps to positive voltages. The large conductance channel also adopts a bursting mode which seems to be quite a general feature of biological membrane channels (W.Hanke and G.Boheim, in preparation). The ion selectivity of the large conductance channel was measured by using a K⁺-Ringer solution. The conductance for K⁺ ions Λ_{L,K^+} is 70 pS giving a selectivity ratio for this type of channel of $\Lambda_{L,Na^+}:\Lambda_{L,K^+} = 2.2:1$. Thus the small conductance channel discriminates better between Na⁺ and K⁺ than the large conductance channel although both channels have a preference for Na⁺ over K⁺.

Pharmacological properties of reconstituted Na⁺-channels

A very critical test for Na⁺-channel identification is its sensitivity to specific neurotoxins. The blockade of Na⁺-channel activity by saxitoxin (STX) is shown in Figure 5a. At time zero STX (1 μ M) was applied to the *cis* side of the reconstituted membrane system after having checked for the presence of both the large conductance and the small conductance channels. The 'small' and highly Na⁺-selective channel is the first one to be blocked within 5 min; then after 10-15 min the large conductance channel is also blocked. Addition of STX to the *trans* side instead of the *cis* side had no effect on the activity of the reconstituted Na⁺-channels.

Figure 5b shows the effect of toxin II from *Centruroides suffusus* on the large conductance channel. The addition of 0.1 μ M scorpion toxin leads to bursting channels of longer mean life-time. This effect has similarities with the effect of

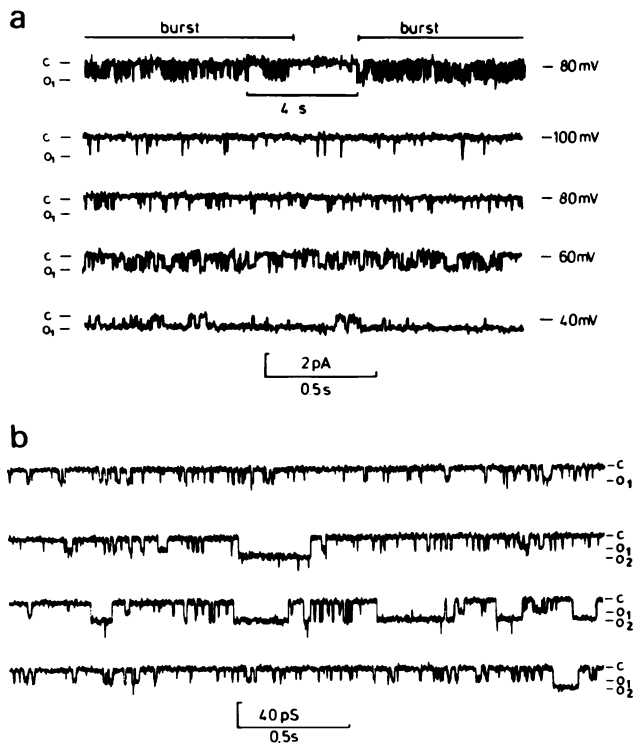

Fig. 3. Properties of the small conductance channel: (a) bursting behavior and voltage dependence of channel state distributions, (b) non-integral conductance levels. (a) **upper trace**, channel activity occurs in bursts of several seconds duration. Bursts are interrupted by silent periods. At constant applied voltage the channel continues to fluctuate for minutes and then suddenly disappears. **The four lower traces**, voltage dependence of the distribution between the open ('o') and closed ('c') states. The most negative voltages drive the channel into the closed state, whereas it is mainly open at less negative voltages. Notice, however, that the channel again is in a non-conducting state at positive membrane voltages (see Figure 2). Channel state distributions remained unchanged when the voltage was changed slowly or abruptly to the positive or to the negative direction. (b) Continuous traces at -75 mV which shows the alternative expression of two different conductance levels (the open states O_1 and O_2 corresponding to conductances $\Lambda_{S1} = 25$ pS and $\Lambda_{S2} = 40$ pS, respectively). Statistical analysis indicates that both levels result from the same channel type. The two state modification is only expressed by $\sim 5\%$ of the small channels observed. Experimental conditions are the same as in Figure 2.

the local anaesthetic QX 222 on the nicotinic channel (Neher and Steinbach, 1978). The conductance of the channel is not altered by the scorpion toxin.

A pronounced change in the gating behaviour of the large conductance channel is observed after addition of $1 \mu\text{M}$ toxin V from *Anemonia sulcata* (Figure 5c). A voltage jump to negative voltages opens the channel after a delay period and then the channel stays open for several minutes in the presence of the sea anemone toxin. Closing of the channel is obtained after a delay following application of a positive voltage. The conductance of the large channel is not affected by the sea anemone toxin which strongly prolongs the lifetime of the open form of the Na^+ -channel.

Discussion

This paper reports for the first time that Na^+ -channels can be successfully incorporated into planar lipid bilayers and electrically expressed even in the absence of toxins capable of producing a chemical activation of the Na^+ -channel. Interestingly, the properties of Na^+ -channels after reconstitu-

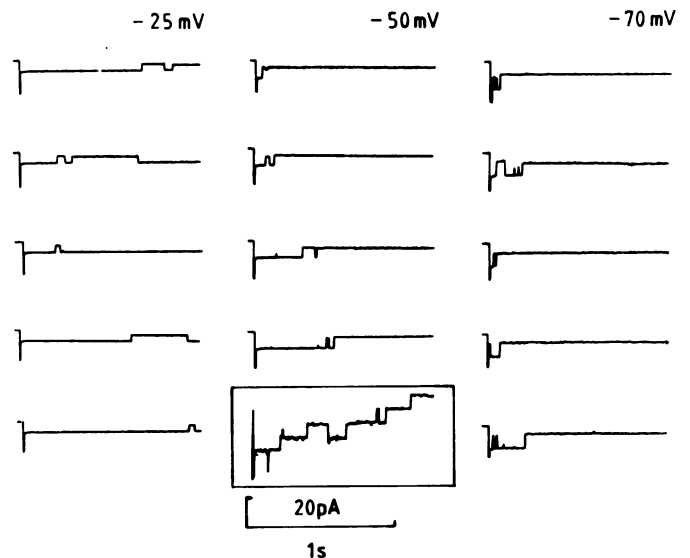

Fig. 4. Properties of the large conductance channel: voltage dependence of the lifetimes of the bursts of open-closed transitions after voltage jumps from 0 mV to the indicated values. The lowest trace in the series of jumps to -50 mV shows a multi-channel situation. At least five channels, which were simultaneously present, are closing at different times. No channel activity is seen at a constant applied voltage, i.e., the channel adopts an 'inactivated' state. Other experimental conditions are the same as in Figure 2.

tion are the same when using the crude synaptosomal membrane fraction containing unpurified Na^+ -channels, or the extensively purified Na^+ -channel preparation in which Na^+ -channel enrichment is at least 1000-fold.

Na^+ -channel preparations used in this work give rise, after reconstitution, to two different types of ion conducting channels in the absence of any of the specific neurotoxins. The first type of channel is highly selective for Na^+ over K^+ . It shows a voltage dependent bursting behaviour and may persist for minutes. The conductance of this channel is 25 pS (and 40 pS) in Na^+ -Ringer. The second type of channel is much less selective for Na^+ over K^+ , it disappears rapidly after the voltage jump and has a conductance near 150 pS in Na^+ -Ringer. Voltage jump applications seem to be a prerequisite for activation of both channel types.

The reconstituted Na^+ -channel characterized as the 'small' channel is similar by its conductance of 25 pS to Na^+ -channels that have been described in a variety of cells using the patch-clamp technique. Conductances measured for Na^+ -channels in chromaffin cells (Fenwick *et al.*, 1982), rat skeletal muscle cells (Sigworth and Neher, 1980) and cardiac cells (Cachelin *et al.*, 1983) are between 15 and 18 pS. The selectivity of $\sim 10:1$ found for Na^+ over K^+ for the reconstituted Na^+ -channel with a small conductance is also similar to the known selectivity (permeability ratio 12:1) reported from voltage-clamp experiments on the frog node of Ranvier (Hille, 1975). As for Na^+ -channels inserted in membranes of excitable cells, the activity of the reconstituted Na^+ -channels is eliminated by $1 \mu\text{M}$ STX. Moreover, STX only blocks the activity of the reconstituted Na^+ -channels when it is applied to the *cis* side of the bilayer, i.e. to the side on which incorporation of vesicles containing the Na^+ -channel has been made. It is well known that STX (or tetrodotoxin) only acts when applied to the external face of excitable cells: it is inactive if it is applied by internal perfusion (Narahashi, 1974). Since the reconstituted Na^+ -channel

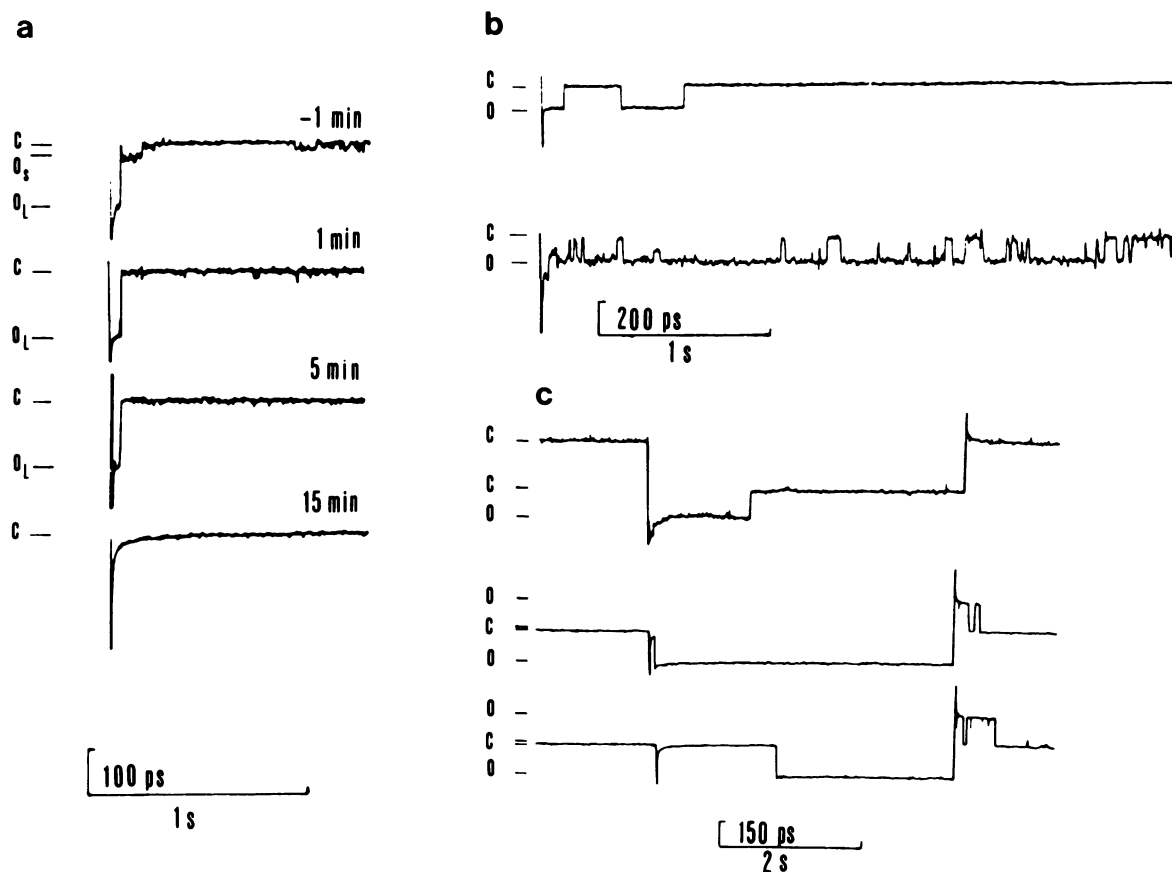

Fig. 5. Pharmacological properties of reconstituted Na⁺-channels. **(a)** Four current traces from a continuous pulse series after voltage jumps from 0 mV to -75 mV are shown at different times after the addition of 1 μM SXT. 1 min before saxitoxin addition both channel types are visible. Within 5 min the first channel to be blocked is the one with a small conductance; then after 15 min the 'large' channel is also blocked. **(b)** The kinetic behaviour of the 'large' channel before (**upper trace**) and after (**lower trace**) application of toxin II from *C. suffusus*. Frequent transitions between the open ('o') and closed ('c') states are observed after addition of 0.1 μM scorpion toxin. Voltage jumps are from 0 mV to -25 mV. **(c)** Toxin V from *A. sulcata* also modifies the behavior of the large conductance channel. The upper trace in the figure shows the unmodified channel under conditions of voltage jumps between +50 mV and -50 mV. At -50 mV the channel opens without delay and then closes. The abrupt change to +50 mV induces no channel activity. Two examples of the modifications observed following the addition of 1 μM sea anemone toxin are shown on the two lower traces corresponding to the same voltage jumps. A delay of channel opening occurs and then the channel may stay open for minutes. After the voltage jump to +50 mV, the channel closes with a time constant similar to that of channel activation at -50 mV. Other experimental conditions are the same as in Figure 1b using the sucrose gradient purified preparation (8×10^{-9} g protein/ml). The ohmic background conductance of the unmodified bilayer is quite large ($\lambda \sim 100$ pS) probably due to the effect of remaining detergent. This is reduced by at least one order of magnitude after the addition of sea anemone toxin.

exposes its STX-binding site to the *cis* side of the bilayer, this side would be the equivalent of the external face of an excitable membrane.

Reconstitution experiments using synaptosomal membrane fragments from rat brain and decane-containing bilayers (Krueger *et al.*, 1983) have shown no single channel activity except in the presence of batrachotoxin used to activate chemically reconstituted Na⁺-channels. The unit channel conductance of this batrachotoxin activated Na⁺-channel is 30 pS in 0.5 M NaCl and is comparable with that of the 'small' Na⁺-channel found in this work.

The channel with the large conductance of 150 pS and a selectivity of ~2:1 for Na⁺ over K⁺ has not yet been identified by patch-clamp studies on excitable cells. Therefore, no comparison of conductance or selectivity can yet be made with Na⁺-channels having similar characteristics in natural excitable membranes. The main indication that the large conductance channel is indeed a Na⁺-channel comes from its pharmacological properties. The voltage-sensitive Na⁺-channel of excitable cells is the pharmacological receptor of a large number of specific neurotoxins. At present these neurotoxins are divided into five different classes (Barhanin *et al.*,

1982). One class including saxitoxin and tetrodotoxin blocks the Na⁺-channel by binding at or near the selectivity filter. Polypeptide toxins of another class, to which toxin II from the scorpion *Centruroides suffusus* belongs, reduce the size of the Na⁺ current in frog nodes of Ranvier (Meves *et al.*, 1982; Hu *et al.*, 1983) and in frog skeletal muscle cells (Jaimovich *et al.*, 1982; Barhanin *et al.*, 1984). They change the P_{Na} (V) curve to more negative membrane potentials and create measurable inward Na⁺ currents at potentials at which the fast Na⁺ conductance is not normally activated (Barhanin *et al.*, 1983a; Meves *et al.*, 1982; Hu *et al.*, 1983). Voltage-clamp experiments have shown that polypeptide toxins belonging to a third class, in which toxin V from *A. sulcata* is a potent representative (Schweitz *et al.*, 1981), slow down the inactivation of the Na⁺-channel (Romey *et al.*, 1975, 1976). The reconstituted channel with a large conductance reacts to the addition of the different toxins in the following way: (i) like the Na⁺-channel of small conductance, it is blocked by 1 μM STX as previously discussed; (ii) its properties are changed by *C. suffusus* toxin II which induces frequent transitions between the open and closed states; (iii) toxin V from *A. sulcata* causes a delay in channel opening and virtually prevents chan-

nel closing for negative voltage jumps; (iv) like STX, the polypeptide toxins are only active from the *cis* side of the bilayer which has been shown before to be equivalent to the external membrane side of excitable cells.

All these results taken together indicate: (i) that the large conductance channel is sensitive to three toxins from three different classes which are specific for Na⁺-channels in natural membranes; (ii) that the reconstituted channel is affected by these toxins in three different ways consistent with voltage-clamp data obtained for Na⁺ channels in natural excitable membranes; (iii) that the membrane side for toxin action is the same in natural and in artificial membranes. Thus, it seems quite safe to conclude that the large channel is indeed a Na⁺-channel.

The identification of two types of reconstituted Na⁺-channels may suggest that the isolation procedure has led to the purification of iso-channels (quoted by analogy with isozymes) with a similar molecular structure and somewhat different functional properties (conductance, selectivity, activation-inactivation kinetics). The occurrence of two different reconstituted channel types would be consistent with recent observations that there are different tetrodotoxin (or saxitoxin) sensitive Na⁺-channels in excitable cells (Jaimovich *et al.*, 1983; Frelin *et al.*, 1983; Renaud *et al.*, 1983; Sherman *et al.*, 1983; Barhanin *et al.*, 1984) although the conductances of these different channels are not known precisely yet. However, the observation of the spontaneous transformation of the large channel type into the small one favors the interpretation that the different types of channel conductances correspond to different conformations of the same channel protein. The mechanism of this transformation is not yet clear. One cannot completely exclude the possibility that the high conductance of one of the two types of reconstituted Na⁺-channels is due to the environment of the Na⁺-channel protein in the lipid/cholesterol bilayer. This environment is of course different from the one present in a natural membrane.

Finally, results presented in this paper show that purification of Na⁺-channels and re-incorporation into artificial bilayers might become a powerful way to analyze the physico-chemical properties underlying the gating mechanism of these channels. This type of approach might have advantages over the patch-clamp technique applied to natural membranes in which STX-sensitive Na⁺-channels have to be identified among different other channels specific for ions other than Na⁺ or among channels which accept Na⁺ but which are not inhibited by STX.

Materials and methods

Purification and reconstitution of the Na⁺-channel from rat brain and from E. electricus electroplax

Na⁺-channel purification from a crude synaptosomal fraction (P₂) from whole rat brain was performed by ion-exchange chromatography, affinity chromatography on WGA and sucrose gradient sedimentation as previously described (Barhanin *et al.*, 1983a). The elution of the WGA column was carried out in a slightly modified buffer containing 140 mM NaCl, 0.5 mM MgSO₄, 25 mM Hepes-Tris at pH 7.4, 0.1% Triton X-100, 0.02% phosphatidylcholine and 150 mM N-acetylglucosamine. The same buffer containing 5–20% sucrose instead of N-acetylglucosamine was used in sucrose gradient sedimentation. All purification steps were taken in the presence of trace amounts of iodinated γ -toxin from the scorpion *Tityus serrulatus* (¹²⁵I)Tity γ which was used as a marker of the Na⁺-channel during the isolation (Barhanin *et al.*, 1983a).

Peak fractions of the WGA column or of the sucrose gradients were used immediately for reconstitution into phospholipid vesicles. Triton X-100 [3.4% (w/v)] in a NaCl medium (140 mM NaCl, 0.5 mM MgSO₄, 25 mM Hepes-

Tris at pH 7.4, 150 mM sucrose) containing 2.6% (w/v) egg phosphatidylcholine (Sigma, type VE) and 2.6% (w/v) egg phosphatidylethanolamine [Lipid Products, S.Nutfield NR (Redhill), grade I] was added to the purified Na⁺-channel bringing the final concentration of Triton X-100 and phospholipids to 0.66% (w/v) and 0.89% (w/v), respectively. Then, 0.15 g/ml of Bio-Beads SM2 (BioRad) washed according to Holloway (1973) and dithiothreitol (final concentration 0.01%) were added to the preparation and the flask was closed under nitrogen and rotated at 4°C. After 3 h, the beads were removed by filtration through glass wool and replaced with an identical volume of fresh Bio-Beads. The samples were then rotated again overnight at 4°C. They were used in reconstitution experiments with planar lipid bilayers directly after removal of the Bio-Beads. They could also be kept frozen in liquid nitrogen before use in reconstitution experiments. The whole procedure gave an incorporation into phospholipid vesicles of 20–60% of the total protein content of the preparation. The pattern of migration of proteins of the reconstituted material in SDS-gel electrophoresis at different steps of the purification remains essentially the same as that of the soluble material.

The maximal specific activity of a Na⁺-channel with a mol. wt. of 270 000 would be 3.7 nmol bound toxin per mg of protein. The activity attained in the rat brain preparation used here is 2 nmol/mg of protein. This difference is mainly due to the fact that at the end of the purification there is a mixture of active and inactive channels because the Na⁺-channel once solubilized has a half-life of 79 h at 0°C and lower than 5 min at 25°C (Barhanin *et al.*, 1983a). Once purified and incorporated into liposomes the Na⁺-channel is stable even at room temperature and for periods of hours.

The Na⁺-channel from *E. electricus* electroplax was purified according to Norman *et al.* (1983) using [¹²⁵I]Tity γ as a marker. The reconstitution of the most purified fraction was performed exactly as described for the brain Na⁺-channel using the same phospholipid composition and in the presence of 0.01% dithiothreitol.

Materials

Materials used in the membrane preparation and in the purification of the Na⁺-channel were described previously (Norman *et al.*, 1983; Barhanin *et al.*, 1983a). STX was kindly provided by Dr. E.J. Schantz. Toxin V from *A. sulcata* and toxin II from *C. suffusus* were prepared as previously described (Schweitz *et al.*, 1981; Wheeler *et al.*, 1982). 1-Stearoyl-2-oleoyl-glycero-3-phosphocholine (1,2-SOPC) with a main phase transition temperature of T_c \approx 6°C (Davis *et al.*, 1981) was purchased from Avanti. Soybean phosphatidylethanolamine (S-PE) was purified from soybean lipids (type II-S from Sigma) by column chromatography on silica gel and DEAE-cellulose. Cholesterol (Sigma) was >99% pure. Salts, reagents and solvents were of P.A. grade. All salt solutions were filtered through microfilters (pore size 0.2 μ m).

Bilayer experiments

Virtually solvent-free bilayers were formed according to Montal and Mueller (1972) from a solution of lipid in hexane/ethanol (9:1). We used teflon sandwich septa with a hole of \sim 150 μ m diameter (Boheim *et al.*, 1983). The lipid mixture consisted of 1,2-SOPC/S-PE/cholesterol in a molar ratio of 20:75:5. Cholesterol was added to the bilayer lipids, since it is known that cholesterol is needed for the physiological expression of the Na⁺-channel protein (Renaud *et al.*, 1982). The principle of the mechanical set-up and electronic equipment is described elsewhere (Boheim and Kolb, 1978). Vesicle preparations were always added to the *cis* side. Since we found that STX blocked the reconstituted channels only from the *cis* side, we defined this side as ground. Thus the voltage sign refers to the *trans* side of the bilayer system. Under physiological conditions, the *trans* side would correspond to the inside of the cell. Current is designated as negative if cations are translocated from the *cis* to the *trans* side (inward current). The data presented in the figures have not been corrected by subtracting the ohmic background conductance of the bilayer which was linearly related to the voltage and insensitive to STX.

Acknowledgements

This work was supported by the Deutsche Forschungsgemeinschaft (SFB 114), by the Centre National de la Recherche Scientifique, by the Fondation de la Recherche Médicale and by the Ministère de l'Industrie et de la Recherche (grant no. 81.E.0575). We are grateful to Dr. Georges Romey and to Dr. Henk Vijverberg for their very useful comments on this work and to Dr. Romey for making his electrophysiological set-up available to us.

References

- Barchi, R.L., Cohen, S.A. and Murphy, L.E. (1980) *Proc. Natl. Acad. Sci. USA*, **77**, 1306-1310.
- Barhanin, J., Giglio, J.R., Leopold, P., Schmid, A., Sampaio, S.V. and Lazdunski, M. (1982) *J. Biol. Chem.*, **257**, 12553-12558.

- Barhanin, J., Pauron, D., Lombet, A., Norman, R.I., Vijverberg, H.P.M., Giglio, J.R. and Lazdunski, M. (1983a) *EMBO J.*, **2**, 915-920.
- Barhanin, J., Schmid, A., Lombet, A., Wheeler, K.P., Lazdunski, M. and Ellory, J.C. (1983b) *J. Biol. Chem.*, **258**, 700-702.
- Barhanin, J., Ildefonse, M., Rougier, O., Sampaio, S.V., Giglio, J.R. and Lazdunski, M. (1984) *Pflügers Arch.*, **400**, 22-27.
- Boheim, G. and Kolb, H.A. (1978) *J. Membr. Biol.*, **38**, 99-150.
- Boheim, G., Hanke, W., Barrantes, F.J., Eibl, H., Sakmann, B., Fels, G. and Maelicke, A. (1981) *Proc. Natl. Acad. Sci. USA*, **78**, 3586-3590.
- Boheim, G., Hanke, W., Methfessel, C., Eibl, H., Kaupp, U.B., Maelicke, A. and Schultz, J.E. (1982) in Antolini *et al.* (eds.), *Transport in Biomembranes: Model Systems and Reconstitution*, Raven Press, NY, pp. 87-97.
- Boheim, G., Hanke, W. and Jung, G. (1983) *Biophys. Struct. Mech.*, **9**, 181-191.
- Cachelin, A.B., De Peyer, J.E., Kokubun, S. and Reuter, H. (1983) *J. Physiol.*, **340**, 389-401.
- Davis, P.J., Fleming, B.D., Coolbear, K.P. and Keogh, K.M.W. (1981) *Biochemistry (Wash.)*, **20**, 3633-3636.
- Fenwick, E.M., Marty, A. and Neher, E. (1982) *J. Physiol.*, **331**, 599-635.
- Frelin, C., Vigne, P. and Lazdunski, M. (1983) *J. Biol. Chem.*, **258**, 7256-7259.
- Goldin, S.M., Rhoden, V. and Hess, E.J. (1980) *Proc. Natl. Acad. Sci. USA*, **77**, 6884-6888.
- Hartshorne, R.P. and Catterall, W.A. (1981) *Proc. Natl. Acad. Sci. USA*, **78**, 4620-4624.
- Hille, B. (1975) in Eisenman, G. (ed.), *Membranes*, vol. 3, M. Dekker, NY, pp. 255-323.
- Holloway, P.W. (1973) *Anal. Biochem.*, **53**, 304-308.
- Horn, R., Patlak, J. and Stevens, C.F. (1981) *Nature*, **291**, 426-427.
- Hu, S.L., Meves, H., Rubly, N. and Watt, D.D. (1983) *Pflügers Arch.*, **397**, 90-99.
- Jaimovich, E., Ildefonse, M., Barhanin, J., Rougier, O. and Lazdunski, M. (1982) *Proc. Natl. Acad. Sci. USA*, **79**, 3896-3900.
- Jaimovich, E., Chicheportiche, R., Lombet, A., Lazdunski, M., Ildefonse, M. and Rougier, O. (1983) *Pflügers Arch.*, **397**, 1-5.
- Krueger, B.K., Worley, J.F. and French, R.J. (1983) *Nature*, **303**, 172-175.
- Methfessel, C. and Boheim, G. (1982) *Biophys. Struct. Mech.*, **9**, 35-60.
- Meves, H., Rubly, N. and Watt, D.D. (1982) *Pflügers Arch.*, **393**, 56-62.
- Miller, C. (1978) *J. Membr. Biol.*, **40**, 1-23.
- Miller, J.A., Agnew, S.W. and Levinson, S.R. (1983) *Biochemistry (Wash.)*, **22**, 462-470.
- Montal, M. and Mueller, P. (1972) *Proc. Natl. Acad. Sci. USA*, **69**, 3561-3566.
- Moore, H.P.H., Fritz, L.C., Raftery, M.A. and Brokes, J.P. (1982) *Proc. Natl. Acad. Sci. USA*, **79**, 1673-1677.
- Narahashi, T. (1974) *Physiol. Rev.*, **54**, 813-889.
- Neher, E. and Steinbach, J.H. (1978) *J. Physiol.*, **277**, 153-176.
- Norman, R.I., Schmid, A., Lombet, A., Barhanin, J. and Lazdunski, M. (1983) *Proc. Natl. Acad. Sci. USA*, **80**, 4164-4168.
- Renaud, J.F., Scanu, A.M., Kazazoglou, T., Lombet, A., Romey, G. and Lazdunski, M. (1982) *Proc. Natl. Acad. Sci. USA*, **79**, 7768-7772.
- Renaud, J.F., Kazazoglou, T., Lombet, A., Chicheportiche, R., Jaimovich, E., Romey, G. and Lazdunski, M. (1983) *J. Biol. Chem.*, **258**, 8799-8805.
- Romey, G., Chicheportiche, R., Lazdunski, M., Rochat, H., Miranda, F. and Lissitzky, S. (1975) *Biochem. Biophys. Res. Commun.*, **64**, 115-121.
- Romey, G., Abita, J.P., Schweitz, H., Wanderer, G. and Lazdunski, M. (1976) *Proc. Natl. Acad. Sci. USA*, **73**, 4055-4059.
- Schindler, H. and Quast, U. (1980) *Proc. Natl. Acad. Sci. USA*, **77**, 3052-3056.
- Schweitz, H., Vincent, J.P., Barhanin, J., Frelin, C., Linden, G., Hugues, M. and Lazdunski, M. (1981) *Biochemistry (Wash.)*, **20**, 5245-5252.
- Sherman, S.J., Lawrence, J.C., Messner, D.J., Jacoby, K. and Catterall, W.A. (1983) *J. Biol. Chem.*, **258**, 2488-2495.
- Sigworth, F.J. and Neher, E. (1980) *Nature*, **287**, 447-449.
- Talvenheimo, J.A., Tamkun, M.M. and Catterall, W.A. (1982) *J. Biol. Chem.*, **257**, 11868-11871.
- Tanaka, J.C., Eccleston, J.F. and Barchi, R.L. (1983) *J. Biol. Chem.*, **258**, 7519-7526.
- Villegas, R., Villegas, G.M., Condrescu-Guidi, M. and Suarez-Mata, F. (1980) *Ann. N.Y. Acad. Sci.*, **358**, 183-203.
- Wheeler, K.P., Barhanin, J. and Lazdunski, M. (1982) *Biochemistry (Wash.)*, **21**, 5628-5634.
- Wilmsen, U., Methfessel, C., Hanke, W. and Boheim, G. (1983) in Spach, G. (ed.), *Physical Chemistry of Transmembrane Ion Motions*, Elsevier, Amsterdam, pp. 479-485.

Received on 5 October 1983; revised on 27 December 1983