



Since January 2020 Elsevier has created a COVID-19 resource centre with free information in English and Mandarin on the novel coronavirus COVID-19. The COVID-19 resource centre is hosted on Elsevier Connect, the company's public news and information website.

Elsevier hereby grants permission to make all its COVID-19-related research that is available on the COVID-19 resource centre - including this research content - immediately available in PubMed Central and other publicly funded repositories, such as the WHO COVID database with rights for unrestricted research re-use and analyses in any form or by any means with acknowledgement of the original source. These permissions are granted for free by Elsevier for as long as the COVID-19 resource centre remains active.



ELSEVIER

Contents lists available at ScienceDirect

Environment International

journal homepage: www.elsevier.com/locate/envint

Ventilation and laboratory confirmed acute respiratory infection (ARI) rates in college residence halls in College Park, Maryland

Shengwei Zhu^a, Sara Jenkins^a, Kofi Addo^a, Mohammad Heidarinejad^{a,b}, Sebastian A. Romo^a, Avery Layne^a, Joshua Ehizibolo^c, Daniel Dalgo^a, Nicholas W. Mattise^a, Filbert Hong^a, Oluwasanmi O. Adenaiye^a, Jacob P. Bueno de Mesquita^a, Barbara J. Albert^a, Rhonda Washington-Lewis^a, Jennifer German^a, Sheldon Tai^a, Somayeh Youssefi^a, Donald K. Milton^a, Jelena Srebric^{a,*}

^a University of Maryland, College Park, MD 20742, USA

^b Illinois Institute of Technology, Chicago, IL 60616, USA

^c Prince George's Community College, Largo, MD 20774, USA

ARTICLE INFO

Handling Editor: Da Chen

Keywords:

Multi-zone model

Ventilation rate

Acute Respiratory Infection (ARI)

Airborne infection control

Infectious bioaerosols

College dormitory rooms

ABSTRACT

Strategies to protect building occupants from the risk of acute respiratory infection (ARI) need to consider ventilation for its ability to dilute and remove indoor bioaerosols. Prior studies have described an association of increased self-reported colds and influenza-like symptoms with low ventilation but have not combined rigorous characterization of ventilation with assessment of laboratory confirmed infections. We report a study designed to fill this gap. We followed laboratory confirmed ARI rates and measured CO₂ concentrations for four months during the winter-spring of 2018 in two campus residence halls: (1) a high ventilation building (HVB) with a dedicated outdoor air system that supplies 100% of outside air to each dormitory room, and (2) a low ventilation building (LVB) that relies on infiltration as ventilation. We enrolled 11 volunteers for a total of 522 person-days in the HVB and 109 volunteers for 6069 person-days in the LVB, and tested upper-respiratory swabs from symptomatic cases and their close contacts for the presence of 44 pathogens using a molecular assay. We observed one ARI case in the HVB (0.70/person-year) and 47 in the LVB (2.83/person-year). Simultaneously, 154 CO₂ sensors distributed primarily in the dormitory rooms collected 668,390 useful data points from over 1 million recorded data points. Average and standard deviation of CO₂ concentrations were 1230 ppm and 408 ppm in the HVB, and 1492 ppm and 837 ppm in the LVB, respectively. Importantly, this study developed and calibrated multi-zone models for the HVB with 229 zones and 983 airflow paths, and for the LVB with 529 zones and 1836 airflow paths by using a subset of CO₂ data for model calibration. The models were used to calculate ventilation rates in the two buildings and potential for viral aerosol migration between rooms in the LVB. With doors and windows closed, the average ventilation rate was 12 L/s in the HVB dormitory rooms and 4 L/s in the LVB dormitory rooms. As a result, residents had on average 6.6 L/(s person) of outside air in the HVB and 2.3 L/(s person) in the LVB. LVB rooms located at the leeward side of the building had smaller average ventilation rates, as well as a somewhat higher ARI incidence rate and average CO₂ concentrations when compared to those values in the rooms located at the windward side of the building. Average ventilation rates in twenty LVB dormitory rooms increased from 2.3 L/s to 7.5 L/s by opening windows, 3.6 L/s by opening doors, and 8.8 L/s by opening both windows and doors. Therefore, opening both windows and doors in the LVB dormitory rooms can increase ventilation rates to the levels comparable to those in the HVB. But it can also have a negative effect on thermal comfort due to low outdoor temperatures. Simulation results identified an aerobiologic pathway from a room occupied by an index case of influenza A to a room occupied by a possible secondary case.

* Corresponding author.

E-mail address: jsrebric@umd.edu (J. Srebric).

<https://doi.org/10.1016/j.envint.2020.105537>

Received 4 November 2019; Received in revised form 2 January 2020; Accepted 27 January 2020

Available online 03 February 2020

0160-4120/ © 2020 The Authors. Published by Elsevier Ltd. This is an open access article under the CC BY-NC-ND license

(<http://creativecommons.org/licenses/by-nc-nd/4.0/>).

1. Introduction

Respiratory viruses are aerosolized through breathing, talking, coughing or sneezing and may become infectious bioaerosols (La Rosa et al., 2013). Infectious bioaerosols have a capability to simultaneously infect a large number of hosts and cause large outbreaks if the source case rapidly sheds large numbers of infectious bioaerosols, as in the case of measles (Riley et al., 1978). In addition, bio-aerosols are able to reproduce the full spectrum of disease at doses much smaller than those required by a large droplet transmission (Tellier, 2009). Alternatively, when a source case sheds very slowly, secondary attack rates are much lower as suggested in an analysis of human rhinovirus transmission by Myatt et al. (2004). Historically, airborne transmissions have been implicated in transmission of acute respiratory infections (ARIs) in a jail (Hoge et al., 1994), military barracks (Brundage et al., 1988), office buildings (Myatt et al., 2004), college dormitories (Sun et al., 2011), and residential buildings (Yu et al., 2004). Most significantly, an analyses of household intervention studies suggested that approximately half of within-home influenza A transmission resulted from exposure to fine particle infectious bioaerosols (Cowling et al., 2013). What all of these reports have in common is a high occupant density within rooms. What is less clear is movement of viral aerosols between rooms connected via air pathways, as is well described for transmission of tuberculosis (Nardell et al., 1991).

Outbreaks of infectious diseases transmitted via aerosols depend on local environmental conditions that could be controlled to protect human population (Wu et al., 2016). Strategies to protect building occupants from infectious bioaerosols should consider ventilation for its ability to dilute bioaerosol concentrations (Ghosh et al., 2015). A review suggested strong evidence to associate building ventilation and the transmission of ARI via bioaerosols (Li et al., 2007). In a Chinese university, prevalence of self-reported common cold ≥ 6 times in a semester was found to be higher (35% compared to 5%) among students living in dormitories with lower mean ventilation rates (1 L/(s person) compared to 5 L/(s person)) (Sun et al., 2011). In U.S. retail stores, a self-reported common cold infection rate was lower by 43% in stores where ventilation rate was greater (0.5 ACH compared to 1.2 ACH) (Zhao et al., 2015).

Since the 1950s, scientists have attempted to quantify a relationship between ventilation rate and infection risk by airborne transmission (Wells, 1955). The efforts resulted in the famous Wells-Riley equation (Wells, 1955; Riley et al., 1978), which has been widely used to demonstrate the impact of ventilation rates on infection risk by airborne transmission with the Poisson distribution (Zhu et al., 2012; Zhu et al., 2013). The Wells-Riley equation is as follows:

$$P = \frac{C}{S} = 1 - \exp\left(-\frac{Iqpt}{Q}\right) \quad (1)$$

where P is the risk of cross infection, C is the number of case to develop infection, S is the number of susceptible subjects, I is the number of infectors, p is the pulmonary ventilation rate of each susceptible subject (m^3/h), Q is the room ventilation rate (m^3/h), q is the average quantum generation rate produced by one infector (quanta/h) where a quantum of infection is that dose which will on average infect 63% of the exposed, and t is the duration of exposure (h). However, without knowledge of the relationship between exposure to infectious viral aerosols and risk of infection (i.e. viral particles per infectious quantum) for the specified disease, it is not possible to accurately predict risk of infection and optimal ventilation rate. If a proper ventilation rate for airborne infection control is to be derived, in-situ observations of both ventilation and ARI rates are needed in actual buildings.

This study is part of a comprehensive study to develop early biomarkers of contagiousness to identify ARI cases soon after the exposure to an infectious agent and before a case transmits the infection. It is

purposed to investigate ventilation rate impact on the spread of ARI diseases by airborne transmission in two college dormitory buildings at a state university in the U.S. According to the preliminary investigation, the measured average CO_2 level was found to be approximately four times higher in a dormitory building with poor ventilation than the average CO_2 level in a dormitory building with good ventilation (Heidarnejad et al., 2018). Coupling these CO_2 data with the observed viral shedding from 142 influenza cases during 2012–2013 season (Yan et al., 2018), the inhalation exposure during an 8-hour night was calculated by a new equation (Rudnick and Milton, 2003) that originated from Eq. (1). The calculation predicted exposure to 6 to 79 infectious particles per person depending on average ventilation rates in these dormitory rooms (Bueno de Mesquita et al., 2018). These results confirmed the importance for an in-depth understanding of building ventilation impact on airborne transmission.

2. Materials and methods

The multi-zone modeling method is widely accepted for predictions of air infiltration rates, ventilation and concentrations of contaminants, including aerosols, inside buildings. The multi-zone modeling method actually outperforms Computational Fluid Dynamics in the studies focused on long-term dynamic simulations for entire buildings including both mechanical ventilation and air infiltration, if the assumption of well mixed air is applicable. A few studies used multi-zone modeling to characterize temporal variation of air infiltration rates, and contaminant concentrations in actual buildings (Jareemit and Srebric, 2015; Srebric et al., 2008; Wu et al., 2018). However, none of these studies conducted field experiments to simultaneously collect data on ventilation and track ARI incidence for occupants.

The present study used two buildings with widely varying ventilation rates, one with mechanically driven high ventilation and another one with very low natural ventilation rates. In the two studied buildings, field experiments were carried out during the respiratory virus season from January 24th to May 18th, 2018, approximately four months. The data collection effort continuously monitored CO_2 concentrations with 154 sensors primarily located in dormitory rooms. At the same time, ARI incidence was tracked for 120 study participants among 755 students living in these two buildings, and a questionnaire on door/window opening was administered to ARI cases and their close contacts. Further, multi-zone models using CONTAM (Dols and Polidoro, 2015) were created and calibrated with the measured CO_2 data for the buildings. These models were further applied to calculate ventilation rates during the experimental time period. In this study, a ventilation rate refers to the rate of outside air entering the dormitory rooms in these buildings through both mechanical ventilation and infiltration.

The multi-zone model for the building with low ventilation was further used to simulate the spread of influenza A viruses by bioaerosols, and the simulation results were compared to the cumulative incidence of viral ARIs confirmed by quantitative polymerase chain reaction assay of nasal and throat swabs using a TaqMan Array Card assay (Thermo-Fisher, San Jose, CA) for a wide range of viral respiratory pathogens (Harvey et al., 2016). The detailed methodology introduces the two dormitory buildings under investigation, the distributed CO_2 monitoring system, and the multi-zone models.

2.1. Studied college dormitory buildings

This study was conducted in a campus located at College Park, Maryland, with focus on two neighboring dormitory buildings on the same campus that both were constructed in 1962, so they have the same age, construction type, and general maintenance/ operation protocols. Nevertheless, one of them had a recent major renovation including installation of an outdoor air supplied mechanical ventilation system while the other had undergone a partial renovation a few years earlier

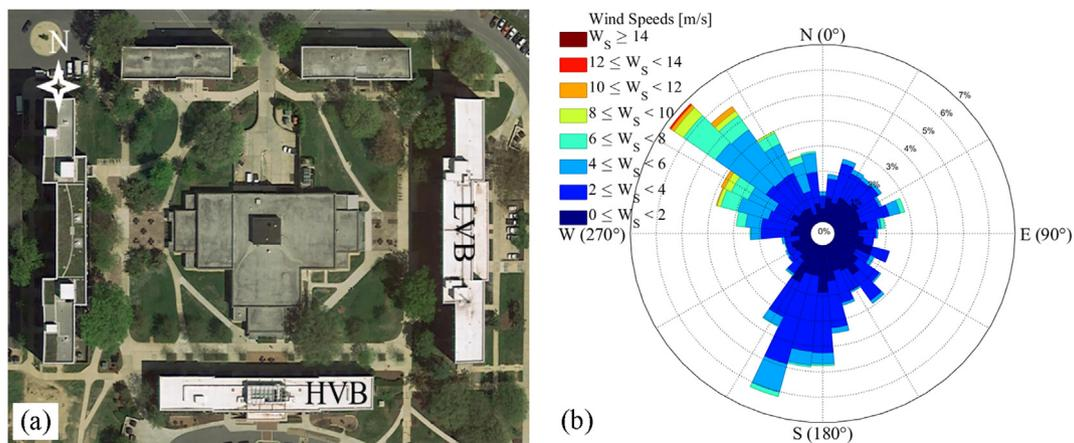

Fig. 1. (a) Spatial relationship of HVB and LVB, and (b) local wind conditions.

with window replacement but no addition of mechanical air supply ventilation, so they were expected to have different rates of outside air entering the buildings. Based on the published literature, differences in ventilation rates should influence the rate of ARIs. Importantly, the set point temperatures for the mechanical air-conditioning systems are the same in these two buildings, i.e. 21 °C in winter and 23 °C in summer, in accordance to the university campus energy standards. These two buildings sit adjacent to each other as shown in Fig. 1(a), so they are exposed to the same wind conditions presented in Fig. 1(b).

The building that is referred to as a high ventilation building (HVB) underwent renovation in 2015 to introduce a Dedicated Outdoor Air System (DOAS) (Mumma, 2001). After the renovation, DOAS provides 100% outside air to all of the HVB dormitory rooms. This building rises 4 stories high with 110 dormitory rooms, including 13 single, 93 double, and 4 triple rooms. Importantly, the building has at least one Air Handling Unit (AHU) on each floor. Every dormitory room has a Fan Coil Unit (FCU) and an inlet for the DOAS to supply outside air. Bathrooms and study lounges have exhaust air returns, driven by a single AHU exhaust fan. The same AHU provides outside air with airflow rates in the range of 7.1–16.5 L/s to dormitory rooms, 37.8–40.1 L/s to lounges, 26.0–73.2 L/s to study rooms, 28.3–44.8 L/s to hallways, and 63.7–169.9 L/s to bathrooms anywhere, depending on room floor areas.

The dormitory building that is referred to as a low ventilation building (LVB) is an 8-story building with 288 dormitory rooms, among which are 58 single, 210 double, 14 triple rooms, and 6 quadruple rooms. The dormitory rooms are located on the 2nd through 8th floor and assigned to two separated heat zones, i.e. north and south wings. Each dormitory room in the building has an FCU for air-conditioning, but no outside air supply. This building only has exhaust air returns in the bathrooms on every residential floor as well as study lounges on the first floor and the basement, which are driven by four exhaust fans. Therefore, ventilation of the dormitory rooms is based on air infiltration through leakage pathways at windows and exterior walls.

Local weather varied in wide ranges during the experimental period, with air temperatures from 0.0 °C to 33.7 °C with average at 9 °C, relative humidity from 15% to 100% with average at 63%, and the wind conditions as illustrated by the wind rose map in Fig. 1(b). The prevalent wind directions were northwest and southwest, but the wind with a speed greater than 6 m/s primarily came from northwest. The LVB dormitory rooms located at the east side (leeward side) of the building should have lower ventilation rates compared to those at the west side (windward side) due to expected lower infiltration rates.

2.2. Field experiments

The field experiments included questionnaires on basic demographic information, respiratory symptoms and contact with others,

sample collection by nasal and throat swabs for ARI identification, as well as monitoring of indoor air temperature, relative humidity and CO₂ concentration in the dormitory buildings. In dormitory buildings, human respiration is the dominant internal CO₂ source. A high CO₂ concentration indicates insufficient ventilation to remove indoor human-sourced bioaerosols, which are associated with exhaled human breath. The airborne infection risk can be evaluated by CO₂ concentrations according to the inherent relationship between exhaled CO₂ and infectious bioaerosols (Rudnick and Milton, 2003). Therefore, in order to quantify ventilation rate impact on laboratory-confirmed ARI attack rates, the focus of this paper is on the monitoring of CO₂ concentrations, analyzed together with the results of the self-reported survey of door/window opening and ARI incidence. The human studies protocol was reviewed and approved by the University of Maryland, College Park, Institutional Review Board and the U.S. Navy Human Research Protections Office.

2.2.1. Monitoring of ARI incidence

The study involved a clinical-epidemiology team that recruited and enrolled participants and monitored ARI incidence among the participants in these two buildings (HVB and LVB) during the experimental period. Students who resided in these buildings and in some other buildings were eligible to enroll in the study and to self-report their illness to the biomedical team for screening. Students enrolled in three academic programs for freshmen were targeted for recruitment. Those residing in the HVB were in a program sponsored by the engineering college. Targeted residents of the LVB were enrolled in programs sponsored by public health and life sciences colleges. The focus of this paper is on the HVB and LVB where the majority of eligible participants resided. Prior to beginning the study, a list of all eligible participants and their e-mail addresses were obtained from the University Registrar and emails were sent to them inviting them to enroll in the study. A unique URL address was emailed to the students to link them to the online informed consent documentation and a questionnaire which contained questions about their baseline health conditions, vaccination history and other relevant social and behavioral information. The participants that had signed the informed consent documentation were then asked to make an appointment in the research clinic to provide baseline biological specimens (upper-respiratory swabs and blood). A second questionnaire was administered and biological specimen collection visit was conducted at the end of the academic year.

Weekly emails were sent to students including the enrollees, to educate them about symptoms of ARI and to remind them to visit the study clinic for screening if they noticed any ARI symptom. At screening for self-reported symptoms, participants were asked to describe their symptoms and date the onset. They were also asked to provide nose and throat swab specimens which were evaluated within 24 h for evidence

of infection with viral pathogens commonly implicated in ARIs (Harvey et al., 2016, Steensels et al., 2015) using a qRT-PCR array (TAC assay, TaqMan® Array Card, Thermo Fisher Scientific, Carlsbad, CA). Participants with confirmed infections with certain viruses including influenza A and B, human coronavirus, adenovirus, respiratory syncytial virus, parainfluenza, and human metapneumovirus (not rhinovirus, enterovirus, other respiratory viruses, or bacterial infections) were further enrolled in an in-depth evaluation and asked to provide details of their close contacts, i.e. people with whom they had interacted in past 24 h, and to provide a 30-minute exhaled breath sample (McDevitt et al., 2013; Milton et al., 2013) in the research team's clinic. Exhaled breath samples were analyzed for influenza virus RNA copy number by qRT-PCR as previously described (Yan et al., 2018) with a lower limit of detection of 250 RNA copies per 30-minute sample (limit of quantification of 2.5×10^3 RNA copies per 30-minute sample) in particles $< 5 \mu\text{m}$ in aerodynamic diameter. Close contacts, (frequently roommates) named by cases enrolled for in-depth evaluation, were invited to enroll in the study and were screened by daily collection of questionnaires and upper-respiratory swabs, analyzed using TAC assays, for upper to 7 days for evidence of infection with viral pathogens and possible transmission. Questionnaires for contacts included symptoms and identification of their close contacts.

According to the questionnaires, the residents of the HVB and LVB were similar with regard to age, gender, hours spent in dormitory room, smoking and asthma prevalence, and body mass index (BMI), as detailed in Table 1. The residents' reported stress levels as measured by the Perceived Stress Scale (PSS) (Cohen et al., 1983) were also similar. There was a trend toward lower rates of influenza vaccination among HVB residents compared with those in the LVB, but it did not reach statistical significance during the experimental period. Moreover, in Table 1, the differences between the means were tested using the Mann-Whitney test, while the differences between two populations were tested using the Fisher exact test. There were no significant differences between the two populations from the HVB and the LVB, respectively.

For estimation of ARI incidence in students, person-time was computed as the interval between the first clinical encounter and the last clinical encounter or survey. Participant who only completed the online baseline survey were not considered to have contributed person time. An ARI detected at the first clinical encounter (e.g. at baseline or a screening visit) was not counted as a case because person-time at risk could not be determined. In other words, only students with at least two study encounters were considered to have been under surveillance during the intervening period between their first study encounter and

Table 1
Characteristics of subjects in HVB and LVB.

Terms	HVB Subjects [N (%)]	LVB Subjects [N (%)]	p-value
Number of subjects	11	109	–
Age (mean \pm SD)	18.8 \pm 0.5	18.9 \pm 0.6	0.96
Female	7 (63.6)	69 (63.3)	1.00
Hours/day in room ^a (mean \pm SD)	12.1 \pm 3.0	12.6 \pm 2.5	0.81
PSS ^b (mean \pm SD)	20.5 \pm 4.0	19.9 \pm 4.3	0.46
First academic year	8 (72.7)	95 (87.2)	0.81
Smoke	1 (9.1)	9 (8.3)	1.00
Asthma	2 (18.2)	16 (14.7)	0.68
Received influenza vaccine for current year	1 (9.1)	46 (42.2)	0.18
Received influenza vaccine for previous year	2 (18.2)	63 (57.8)	0.14
BMI, Kg/m ² (mean \pm SD)	24.4 \pm 7.4	24.0 \pm 2.7	0.39

Abbreviation. SD: Standard deviation; PSS: Perceived Stress Scale; BMI: Body Mass Index.

^a Response to "In an average 24 h, how many hours do you spend in your own room?".

^b Perceived Stress Scale, a measure of perceived stress. Rated as: mildly stressed (0–13), moderately stressed (14–27), severely stressed (28–40).

their last study encounter. ARI detected after the first clinical encounter were counted. The dormitory buildings were closed during the spring break (March 18th–25th, 2018). As a result, there was no exposure in the dormitory buildings for the participants, and if someone got infected, we could not detect it during the period. Therefore, the days during the spring break were not taken as person-time contribution. Because we tested for multiple viral ARI pathogens, it was possible for a subject to test positive as a case multiple times, each for different viral pathogens, during the study. Dual infections were counted as two infections.

Further details of ARI monitoring will be introduced in other upcoming publications. In this paper, the primary focus is on ARI incidence in two buildings, temporospatial clustering of specific viral infections and the potential for this methodology to conclusively identify the impact of ventilation rate on building associated ARI risk, and to identify scenarios for ARI transmission via aerosols.

2.2.2. Self-report survey of door/window opening

Participants enrolled in the in-depth case evaluation and their close contacts who enrolled in the contact surveillance were asked to complete a questionnaire (once for the cases and daily during follow-up for the contacts), regarding the frequency and time period when the participants opened their windows and door. Thus, by design, data collection about door and window opening was focused on cases and their close contacts and data for other participants' rooms was not obtained. The questions were as follows:

Did you have the window in your dormitory room open during the night?

During the last 24 h, while you were in your dormitory room, did you open the window? About how long did you have it open?

During the last 24 h, while you were in your dormitory room, did you open the door and leave it open? About how long did you have it open?

2.2.3. Measurement of CO₂ concentrations

Two types of wireless sensors, i.e. HOBO (MX1102, Onset Computer Corporation, Bourne, MA) Bluetooth sensors and Paragon Robotics (SC75, Paragon Robotics, LLC, Bedford Heights, OH) Wi-Fi sensors were used in CO₂ measurement. HOBO sensors can measure CO₂ concentrations in the detection range from 0 to 5000 ppm, with an accuracy of ± 50 ppm, while Paragon CO₂ sensors work in the detection range from 0 to 10000 ppm, with an accuracy of ± 100 ppm. Overall, 154 CO₂ sensors in total were evenly dispersed in the dormitory rooms on the 1st through 4th floors of the HVB, and on the 2nd through 7th floors of the LVB, as shown in an example given in Fig. 2. CO₂ sensors were placed high on the wall, opposite to the windows and next to the doors, to avoid being near student beds or desks and receiving a direct plume of exhaled CO₂. This location creates a possibility for an increased sensitivity to airflow with an open door, but this would be less impactful to the measured CO₂ values than direct airflow from a window or exhalation from room occupants. In addition, Gateways/Routers were installed to transfer the data from Paragon sensors to a server. The sensors collected data points every 15 min to conserve batteries and still allow dynamic monitoring in private student dormitory rooms during the four months of the experimentation. The original data collection began in October 2017 and ended in May 2018, which includes test deployments, sensor calibration, and improvements in experimental protocols. Therefore, the data used in the analysis of building ventilation rates and the calibration of the multi-zone models were collected in the final four months of the experimental time period.

The access to the sensors within dormitory rooms was limited to the time period when occupants were on spring break with a few exceptions that required both occupant and the department of resident life permissions. Therefore, a large number of sensors were installed knowing that, over the four months of data collection, some would become faulty

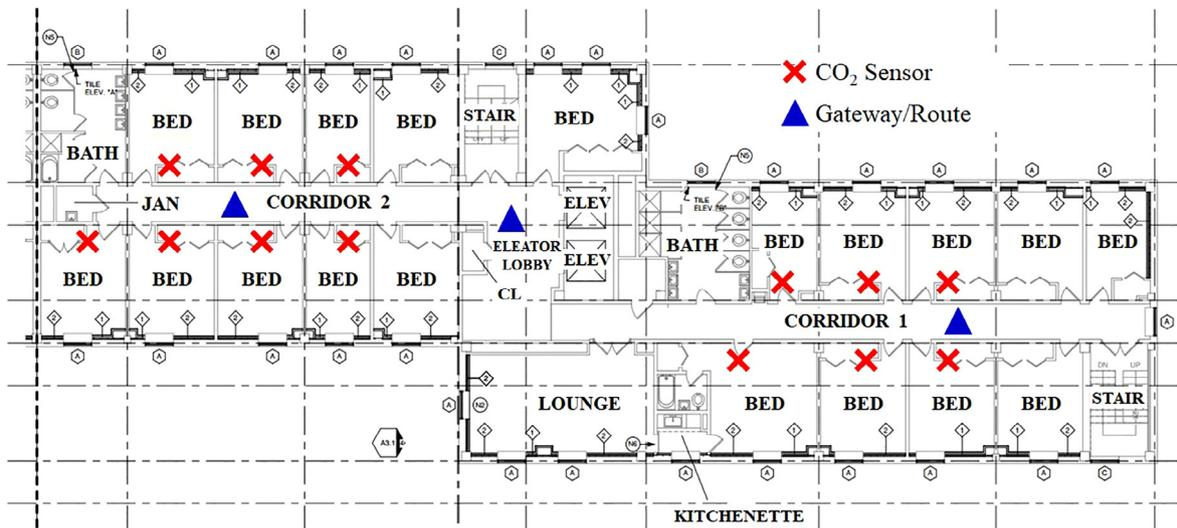

Fig. 2. Sensor deployment plan for the 5th floor at the north wing of the LVB.

and/or unable to provide data for some or all of their life span, a hypothesis which was proved to be correct. In the end, reliable CO₂ data was collected for 103 dormitory rooms, 35 in the HVB and 68 in the LVB, which is 67% of the original 154 deployed sensors. Overall, this experimental effort collected a rather large dataset for dormitory rooms allowing for in-depth analyses during later steps in the study.

In order to use the CO₂ concentrations in the analyses of ventilation rates, each sensor was individually calibrated with a linear equation obtained from a correlation between known and measured CO₂ concentrations. Sensor calibration occurred at two points in time. The initial sensor calibration was done in January 2018, and the final calibration was done in June 2018. The sensors were put in pressurized chambers for three hours at known CO₂ concentrations of 500, 1000, and 5000 ppm. The average steady-state CO₂ concentration in the last 10 min was calculated for each known concentration and the points were used to create a linear curve. The linear equations from each calibration point in time (January and June) were applied to the uncalibrated data as a time-step function, so that the initial and final calibration equations were not equally applied to each date, depending on the time span between data calibration and data collection dates. The following equation uses two calibration curves and combines them to produce a time dependent equation that resulted in calibrated CO₂ concentrations for each measured concentration:

$$y = \frac{N_0 - N_i}{N_0} (a_1 x + b_1) + \frac{N_i}{N_0} (a_2 x + b_2) \quad (2)$$

where N_i is the number of days from the sensor's initial calibration date to the data collection date, N_0 is the total number of days between the two calibration dates for the sensor, a and b are the slopes and intercepts of the respective equations determined from the pressure chamber tests, and x and y are the uncalibrated and calibrated CO₂ concentrations in ppm, respectively. Moreover, the subscript 1 and 2 represent the initial and final calibration, respectively.

2.3. Multi-zone modelling of dormitory buildings

This section will introduce the details of the multi-zone models for two dormitory buildings, as well as the validation of the two models and the setup for the models to calculate ventilation rate and cross-contamination of influenza A viruses in the dormitory buildings.

2.3.1. Multi-zone modeling for dormitory buildings

Multi-zone models for HVB and LVB were created based on floor plans, mechanical schedules, mechanical ventilation network, and

mechanical ventilation system test reports. Each model consists of three components: (1) a building geometry representation, (2) airflow paths for air infiltration, and (3) airflow paths for the mechanical ventilation system. A building geometry representation in a multi-zone model is made up of zones with walls, windows and doors on each floor. Each zone, representing a dormitory room, bathroom, lounge, hallway, or storage, was created according to the volume and height of the actual floor plan. As a result, HVB model had 229 zones and LVB model had 529 zones in total. Fig. 3 shows the representation of multi-zone models for the 4th floor of HVB and the 2nd floor of LVB.

After the physical borders of the dormitory interiors were drawn, the airflow paths were included in the models. Openings were modeled with two types of airflow paths, e.g. closed airflow paths with all of windows and doors closed, and open airflow paths with the windows and doors opened in the dormitory rooms according to the self-reported survey data. Besides windows and doors, airflow paths also included leakages in the interior and exterior walls of the buildings. As a result, there were 983 airflow paths in the HVB model, and 1836 airflow paths in the LVB model.

Fig. 4(a) presents an example for six different airflow paths in an HVB dormitory room. With closed airflow paths, air infiltration through air leakages of windows, doors and walls were calculated with the following equation:

$$Q = C_d A \sqrt{\frac{2\Delta P}{\rho}} \quad (3)$$

where Q is the volumetric airflow rate, which can be taken as the room ventilation rate defined above, [m³/s], C_d is a discharge coefficient [-], which was 1 in the models, A is the leakage area, with its unit to be [cm²] for windows/doors and [cm²/m²] for walls, ΔP is the pressure drop across the opening [Pa], which was set to be 4 Pa according to the CONTAM Flow Element Library (Persily and Ivy, 2001), and ρ is the air density [kg/m³].

For open airflow paths, the study determined whether a door or window was open according to the survey result, and assumed that the doors were opened at 45° and the windows were opened halfway based on observation of two dormitories. Then airflow paths were redefined for the open doors and windows. The volumetric airflow rate Q was calculated using the following equation for both open doors (large openings) and windows (small openings):

$$Q = C_d (\Delta P)^n \quad (4)$$

where n is a flow exponent [-]. In two models, C_d was 0.65 for open doors and 0.6 for open windows, n was 0.5 for open doors and 0.65 for

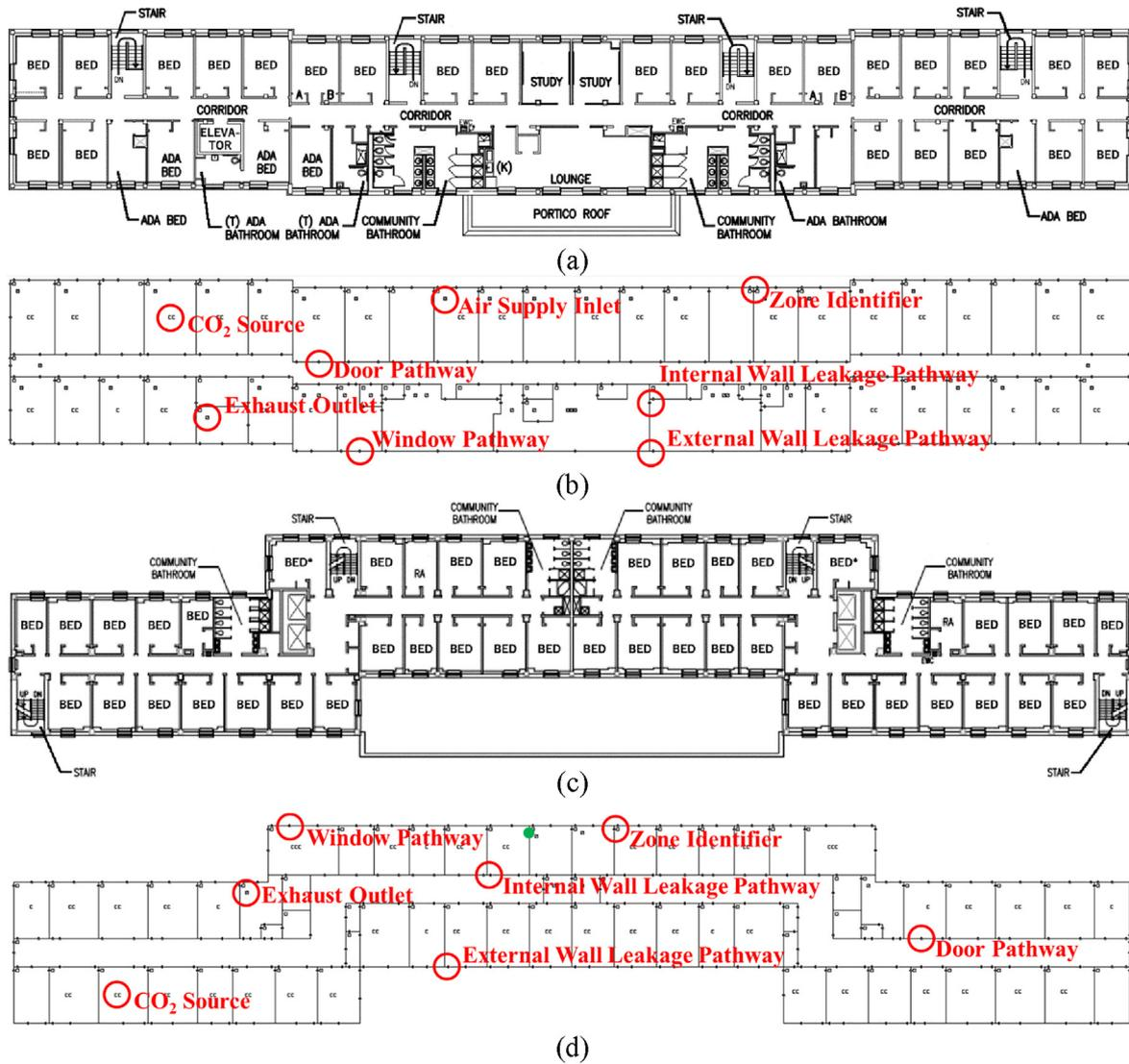

Fig. 3. Multi-zone models for HVB and LVB: (a) floor plan for the 4th floor in the HVB; (b) the 4th floor in the HVB model; (c) floor plan for the 2nd floor in the LVB; (d) the 2nd floor in the LVB model. Green solid circle in (d) highlights the internal wall leakage pathway between the bathroom (RM4 in Fig. 12) and its adjacent bedroom (RM3 in Fig. 12). (For interpretation of the references to colour in this figure legend, the reader is referred to the web version of this article.)

open windows. In Eq. (4), ΔP was calculated as a function of volume flow rate through the windows or doors. The example of open windows is given in Fig. 4(b) for the same room as the one in Fig. 4(a).

The mechanical ventilation systems were integrated in the models as shown in Fig. 3. In both building models, the exhaust outlets in larger

rooms such as the community bathrooms and some of the lounges and study rooms, were defined as air outlets with one-way flow paths. The main difference between the two models was that each individual dormitory room in the HVB model also contained an outside air supply, positioned on an opposite wall to the wall with FCU. The outside air

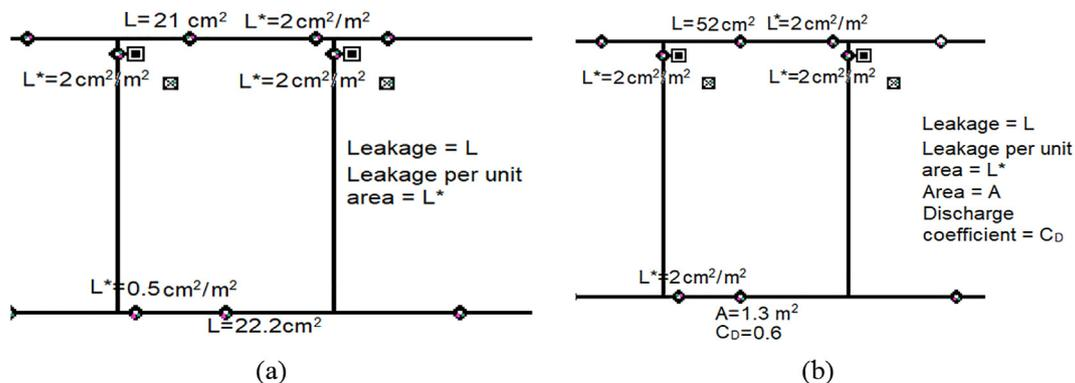

Fig. 4. Airflow paths in a room of the HVB: (a) closed airflow paths; and (b) open airflow paths.

supplies were defined as one-way flow paths into the dormitory rooms, with the amount of airflow corresponding to that defined in the mechanical ventilation system test reports.

2.3.2. Calibration of multi-zone models

Multi-zone models were calibrated with closed airflow paths. Each airflow path and its leakage were calibrated by comparing the measured and simulated CO₂ concentrations for the rooms with available experimental data. For the rooms without experimental data, the leakages were set to be the same as the calibrated ones, a reasonable assumption for buildings with the external enclosure and internal partitions being constructed with the same components at the same time period.

The calibration process used the CO₂ concentrations measured during the nighttime on Tuesdays, Wednesdays and Thursdays, based on the assumption that most of the students should be sleeping in their dormitory rooms. Specifically, the calibration process used the mean CO₂ concentrations during 00:00 and 6:00 on March 27th, 28th and 29th, 2018. In these hours, wind direction varied between 272° and 282° with 278° on average, and wind speed varied between 0.5 m/s and 2.3 m/s. Accordingly, measured CO₂ concentrations reflected the concentration levels under steady source of CO₂ because the changes in occupancy rate were minimal in the studied dormitory rooms. Finally, reliable experimental data in 9 dormitory rooms in the HVB and 12 dormitory rooms in the LVB allowed model calibration of opening characteristic of leakage areas.

The simulations were conducted with the transient weather conditions from the local weather data including hourly air temperatures, ambient air pressures and wind conditions. In addition, we created a schedule for all the residents in the dormitories, assuming they stayed in their rooms from 20:00 to 7:00 of the next day, exhaling CO₂ at a rate of 0.31 L/min. The ambient CO₂ concentration was set to be 432 ppm according to the data measured at Capital Heights, MD by The North East Corridor Project (Loptz-Coto et al., 2017).

2.3.3. Calculations of a seasonal average ventilation rate

With the calibrated multi-zone models, long-term simulations were run to calculate hourly ventilation rates in these two buildings for the study time period during spring 2018. A weather file with hourly inputs from January 24th through May 18th, 2018 was incorporated in the simulations to model accurate transition of ambient pressures, air temperatures and wind directions and speeds. Simulations were run for each building, and the outdoor air flow entering the rooms by mechanical system or infiltration were summed and averaged over the experimental period for each dormitory room. In addition, according to the survey on door/window opening, which was optional, there was a significant use of door/window opening in twenty dormitory rooms of the LVB. With the survey data, ventilation rates were recalculated to account for open airflow paths in these twenty rooms during the hours reported to have had doors and/or windows opened.

2.3.4. Spread of airborne infectious bioaerosols

Clusters of participants representing potential building-related transmission events were identified, regardless of whether they reported each other as close contacts in the questionnaires administered to cases and contacts, by manually examining time of onset and detection and physical location of their assigned dormitory rooms. A pair of influenza A with onset of symptoms on consecutive days and residing in rooms located across the hallway from each other was identified. Symptom onset was February 6th for the first case and February 7th for the second case. The two cases were further analyzed to model the potential for aerosol spread of influenza A viruses from the room of the case with the earlier onset into the surrounding rooms with multi-zone modeling by introducing influenza A virus (RNA copies) bioaerosols as a contaminant in the model. Analysis of influenza aerosols in exhaled breath and air in healthcare facilities consistently demonstrates the

human influenza aerosols are predominantly in the < 5 μm size range (Lindsley et al., 2012; Noti et al., 2012; Milton et al., 2013; Yan et al., 2018). Therefore, in the simulations, bioaerosols were assumed to have an aerodynamic size of < 5 μm, and treated as a gaseous contaminant (Tang et al., 2006). According to the measurement of the clinical-epidemiology team, limit of detection (Armbruster and Pry, 2008) for influenza A virus was 250 virus particles per 30 min sample. The shedding rate was calculated to be 354 viral RNA per hour for the infected occupant in the source room. Considering that influenza may be contagious prior to onset of symptoms, the simulation time period for the spread of infectious bioaerosols was from February 5th to February 7th, 2018. Because we had no information about when the index person stayed in the room, the simulation assumed a continuous source for influenza A virus. The airflow rates were calculated with the LVB model with closed airflow paths and used to map the flow of air and contaminant between the adjacent rooms.

3. Results

We begin by presenting results of in-situ data collection with the focus on the data used to calibrate multi-zone models. Further, the calibrated models provided seasonally averaged ventilation rates for all dormitory rooms in the studied buildings. These datasets provided a foundation for the analyses of a relationship between the ARI incidence and ventilation rates. Finally, a case study with two influenza A cases provided data to investigate potential for infectious bioaerosols to expose occupants of neighboring dormitory rooms.

3.1. Experimental result of CO₂ concentrations

After data collection and sensor calibration, this study executed data cleaning by removing CO₂ concentrations with the values lower than 400 ppm or greater than the upper limits of the sensor detection range. This process resulted in 668,390 useful data points from over 1 million measurements that represented a success rate of roughly 67% in the data collection effort under a very limited access to the sensors. Fig. 5 shows data distribution of the CO₂ concentrations in the dormitory rooms for both HVB and LVB. In both buildings, the data measured by each sensor greatly varied with the hourly occupancy rates, especially evident in the LVB. As shown in Table 2, both the average and standard deviation of CO₂ concentrations were lower in the HVB. These results were expected because, assuming constant generation rates, the lower the ventilation rate the higher CO₂ concentrations due to a slow process of dilution. In accordance with the local wind conditions shown in Fig. 1(b), the average and standard deviation of CO₂ concentrations were higher in the dormitory rooms at the leeward side of LVB. Furthermore, Table 3 also shows that the dormitory rooms at the windward side of the building had a better ventilation and lower ARI rates than those at the leeward side of the LVB. It should be noted that, a total of 4546 CO₂ concentrations measured by 27 HOBO sensors installed in the LVB dormitory rooms exceeded the upper limit of 5000 ppm. This upper detection limit was met in 0.7% of all useful CO₂ data points. Therefore, the variation and the average of CO₂ concentrations in the LVB dormitory rooms are slightly underestimated due to the upper detection limit of HOBO sensors being at 5000 ppm.

Fig. 6 shows the variations of hourly averaged CO₂ concentrations on weekdays and weekends in the double rooms in both buildings. Only the data in double rooms were chosen to directly compare the results in two buildings. This constraint is appropriate because all studied dormitory rooms in the HVB, and 91% of the studied dormitory rooms (62) in the LVB were double rooms. Importantly, Fig. 6 does not include the data measured during the spring break (March 18th–25th, 2018) because these data sets are not representative of typical room conditions when occupants were present. As calculated, daily average CO₂ concentration was 1219 ppm on weekdays and slightly higher with 1231 ppm on weekends in HVB. The daily average CO₂ concentration

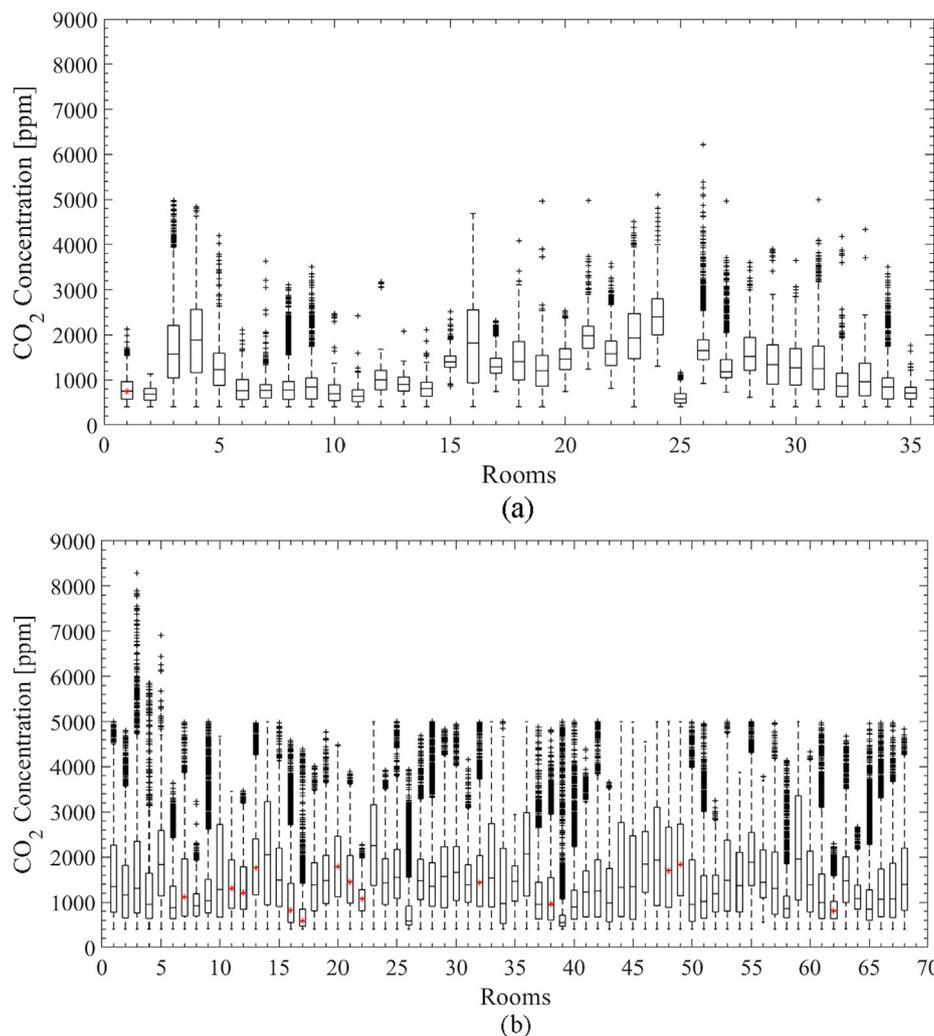

Fig. 5. Measured CO₂ concentrations in the dormitory rooms in: (a) HVB; and (b) LVB, where the red diamonds denote the rooms with ARI cases.

Table 2
Comparison of CO₂ concentrations, room and individual ventilation rates, and ARI rates in the HVB and LVB.

Dormitory buildings		HVB	LVB
Measured CO ₂ concentration in the rooms with sensors	Average [ppm]	1230	1492
	Std. [ppm]	408	837
Calculated ventilation rates in all dormitory rooms	Room [L/s]	12.1	4.0
	Individual [L/(s person)]	6.6	2.3
Calculated ventilation rates in participants' rooms	Room [L/s]	11.8	4.0
	Individual [L/(s person)]	5.9	2.0
Observed ARI infections in participants' rooms	Number/Percent of ARI cases	1/2.1%	47/97.9%
	Person-days contribution	522	6069
	ARI rate per person-year ^a	0.70	2.83

^a Incident rate ratio: 4.04 (CI: 0.69–163.02).

was 1375 ppm on weekdays, and it had a much higher value of 1540 ppm on weekends in the LVB.

According to Fig. 6, the variations of hourly averaged CO₂ concentrations presented different patterns in these two buildings. In the HVB, with steady outside air supply by the DOAS system, the hourly averaged CO₂ concentration for each room were in a repeatable and narrow range throughout the day. In the LVB, infiltration could not

provide sufficient outside air to counteract the changes in CO₂ source strength, i.e. number of occupants. On weekdays, hourly averaged CO₂ concentrations in the LVB rooms and their standard deviations showed a similar variation trend. In the morning, they slowly increased to the peak at around 10 AM. This was more likely to be caused by the increased metabolic activity during waking, not by the increased occupancy. They then decreased as the student left for classes, and started to increase again after 8 PM as most of the students came back their rooms, and finally trended to a stable value after the students fell asleep. The hourly averaged CO₂ concentrations and their standard deviations had a similar variation pattern during weekends, but the peak in the morning and the time of onset in CO₂ increase during the evening both shifted by one hour ahead. The results were consistent with concept that CO₂ generation rates from building occupants generally increases with their physical activity levels (Persily and de Jonge, 2017) and the idea that students usually spent more time in the dormitory and were more active in their dormitory rooms on the weekends. This potentially resulted in a greater exposure risk on the weekends for the students when they were staying in their rooms, because they generated more bioaerosols and had greater inhalation rate.

Moreover, according to the survey data, the students spent on average 11.9 h in their rooms. It's conceivable that most of these hours were spent during the night. Therefore, ARI transmissions in the LVB could have most likely occurred during the nighttime while all residents were asleep, breathing at a constant rate, and providing a constant infectious bioaerosols source flow.

Table 3Comparison of CO₂ concentrations, room and individual ventilation rates, and ARI rates at the leeward and windward sides of the LVB.

Building sides		Windward	Leeward
Measured CO ₂ concentration in the rooms with sensors	Average [ppm]	1400	1596
	Std. [ppm]	777	906
Calculated ventilation rates in all dormitory rooms	Room [L/s]	4.1	3.9
	Individual [L/(s person)]	2.5	2.1
Calculated ventilation rates in participants' rooms	Room [L/s]	4.3	3.9
	Individual [L/(s person)]	2.1	1.9
Observed ARI infections in participants' rooms	Percent of rooms with ARI cases	32.4%	36.4%
	Number/Percent of ARI cases	17/36.2%	30/63.8%
	Person-days contribution	2632	3437
	ARI rate per person-year ^a	2.36	3.19

^a Incident rate ratio: 1.34 (CI: 0.72–2.61).

3.2. Model calibration by CO₂ concentrations

Fig. 7 compares the measured and calculated data in 9 HVB rooms and 12 LVB rooms. The simulated CO₂ concentrations had few variations between the HVB rooms because the room ventilation rates were determined by the DOAS system, almost independent to outside wind conditions. In contrast, the simulated CO₂ concentrations greatly varied between the rooms in the LVB with infiltration ventilation, as well as the experimental data.

We used four metrics to validate the multi-zone models: (1) normalized mean bias error (NMBE) (ASHRAE, 2002), (2) coefficient of variation of root mean square deviation (CVRMSE) (ASHRAE, 2002), (3) percentage mean absolute error (PMAE) (Ayompe et al., 2011), and (4) percentage mean error (PME) (Ayompe et al., 2011). The simulation models of actual buildings are considered to have high quality if a CVRSME is less than 30% and an NMBE is within $\pm 10\%$ when simulated data are compared to hourly measured data (ASHRAE, 2002). These metrics were calculated and presented in Table 4. The order of magnitude given for the metrics indicated reliable results for ventilation rates in the two studied dormitory buildings based on the calculated level of model accuracy. In fact, given different modeling

assumptions and great difficulties in data collection/calibration at the entire building scale, it is very difficult and therefore rarely reported for the validation of such large-scale multi-zone models.

3.3. Seasonal average ventilation rates in two dormitory building

We assessed ventilation rates as the amount of the available outside air both per room and per occupant. Individual ventilation rate for a room was calculated by dividing the room ventilation rate with the number of occupants. This is an important distinction because the actual risk of ARI depends on the ventilation rate per occupant rather than a commonly reported ventilation for room. This distinction also allowed for exploring the influence of population density on the risk of ARI.

3.3.1. Room ventilation rates in all dormitory rooms

We calculated average ventilation rates with the calibrated multi-zone models for the four-month experimental study. Results are shown in Fig. 8. According to Table 2, the HVB had an average ventilation rate three times higher than that in the LVB. We could obtain the similar results if changing the unit to be air change per hour (ACH) (1ACH for HVB compared to 0.3 AVH for LVB). Only one HVB dormitory room had

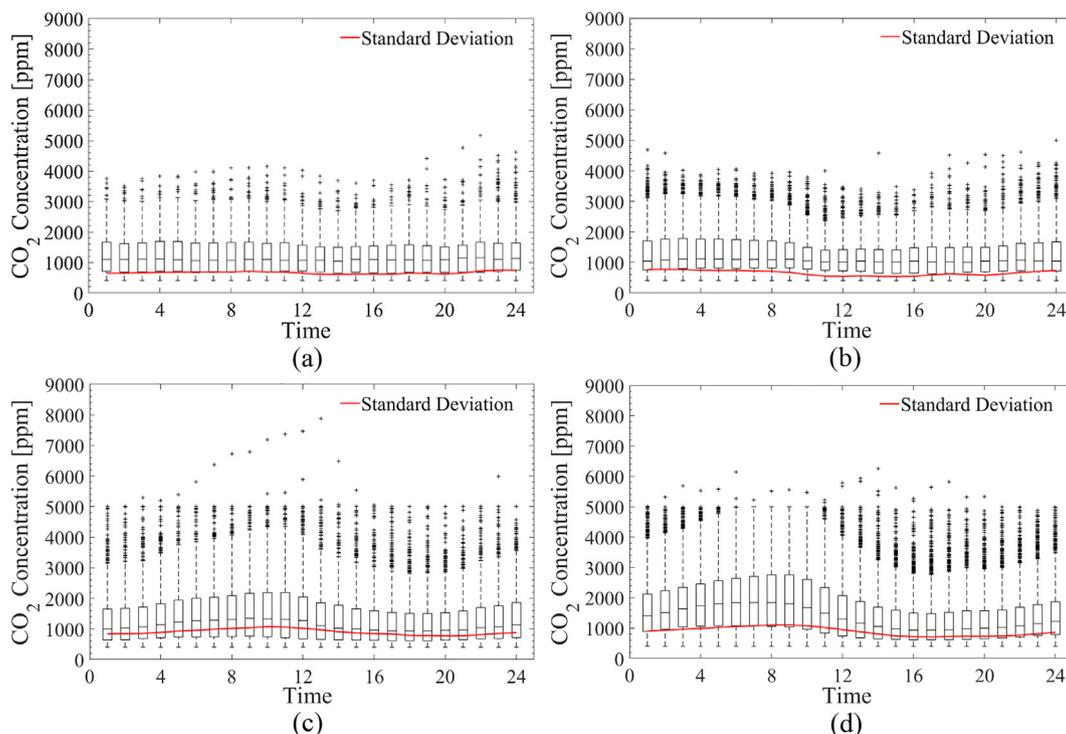

Fig. 6. Hourly averaged CO₂ concentrations in dormitory rooms during: (a) weekdays in the HVB; (b) weekends in the HVB; (c) weekdays in the LVB; and (d) weekends in the LVB.

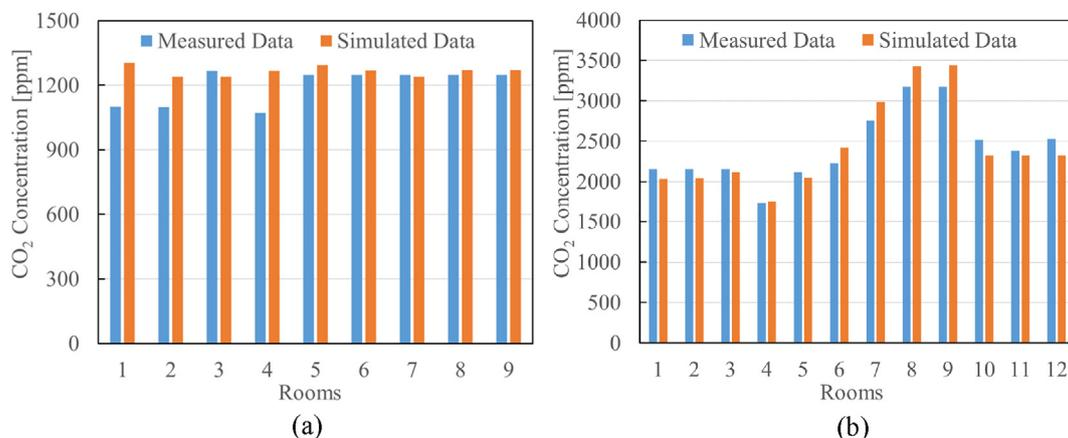

Fig. 7. Comparison of measured and model-calculated mean CO₂ concentrations during 00:00AM and 6:00AM on March 27th, 28th and 29th: (a) HVB; and (b) LVB.

Table 4
Calibration of multi-zone models.

Multizone models	NMBE	CVRMSE	PMAE	PME
HVB	-6.5%	9.5%	6.7%	-6.2%
LVB	-0.5%	7.3%	5.8%	0.1%

a ventilation rate under 9 L/s; in contrast only four of the LVB dormitory rooms had a ventilation rate above 9 L/s. In both buildings, the overall average ventilation rate was determined by the rates in those double rooms because, of all rooms, 85% in the HVB and 73% in the LVB are double rooms. In the HVB, room ventilation rate increased with room occupancy as designed. In contrast, there was no such intentional increase in room ventilation rates with room occupancy in the LVB. Average ventilation rate was a little higher for triple rooms, which are at the corners, marked with “*” in Fig. 3(c). They have three windows while most of dormitory rooms only have one. Furthermore, half of these triple rooms were exposed to the highest wind speeds from the northwest, as illustrated in Fig. 1(b). Moreover, there was a trend toward the average ventilation rate of the rooms at the windward side being higher than that of the rooms at the leeward side of the LVB building, as shown in Table 3, but this was not statistically significant ($t = 0.669, p = 0.504$).

3.3.2. Individual ventilation rates in all dormitory rooms

As shown in Table 2, residents in the HVB had supplied with approximately three times more outside air than those in the LVB. More importantly, a ventilation rate of 5 L/(s person) indicated a threshold to distinguish high ventilation and low ventilation for the buildings, as

shown in Fig. 9. The individual ventilation rates were gradually decreased with the increase in room occupancy, which could not be captured with the room ventilation rate calculations. For example, in the HVB, the residents in single rooms had almost twice the amount of the outside air compared to the amount for those living in triple rooms. The individual ventilation rates in the LVB had the same trend, but much lower values. As a result, only 4.2% of LVB dormitory rooms (12 out of 286) had individual ventilation rates above 5 L/(s person); moreover, all were single rooms except for one double room. And the individual ventilation rate was only 0.76 L/(s person) on average for each resident living in the LVB quadruple rooms. As shown in Table 3, the average individual ventilation rates were lower for the rooms at the leeward side than for the room at the windward side of the LVB building, which was also the case for the room ventilation rates. However, the difference in individual ventilation rates were statistically significant ($t = 2.685, p = 0.008$).

3.4. ARI and ventilation rates in the participant dormitory rooms

Over the course of the four-month study, a total of 120 students from these two buildings who had at least 2 study encounters and were considered to have contributed person-time during which we monitored ARI incidence. Specifically, 11 HVB participants lived in 11 dormitory rooms and contributed 522 person-days of observation while 109 LVB participants lived in 81 dormitory rooms and contributed 6069 person-days of observation. 81 LVB dormitory rooms included 2 single, 70 double, 4 triple and 5 quadruple rooms. There was one laboratory-confirmed ARI case in an HVB room, and 47 cases in 28 LVB rooms, showing a difference in ARI rates in person-year in two buildings (see Table 2). Only three laboratory-confirmed ARI cases, among which one

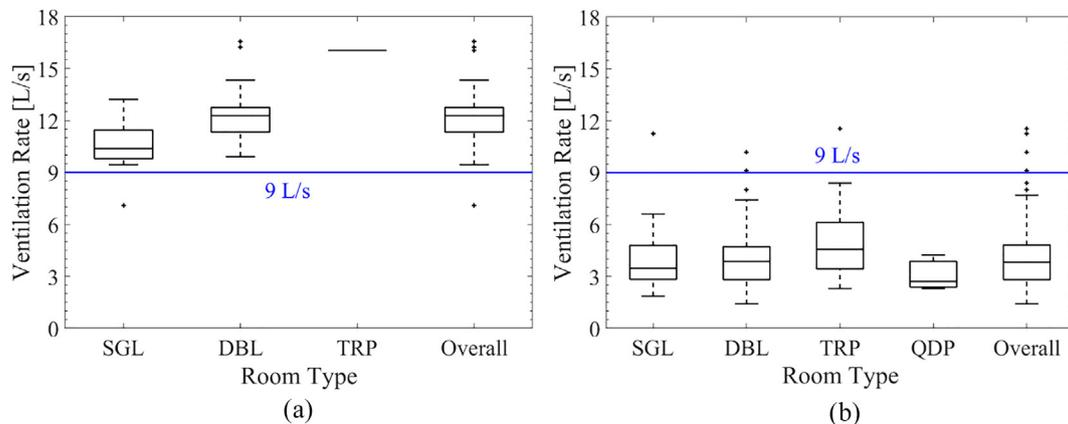

Fig. 8. Room ventilation rates in: (a) HVB; and (b) LVB, where, SGL, DBL, TRP, and QDP denote single, double, triples, and quadruple rooms, respectively.

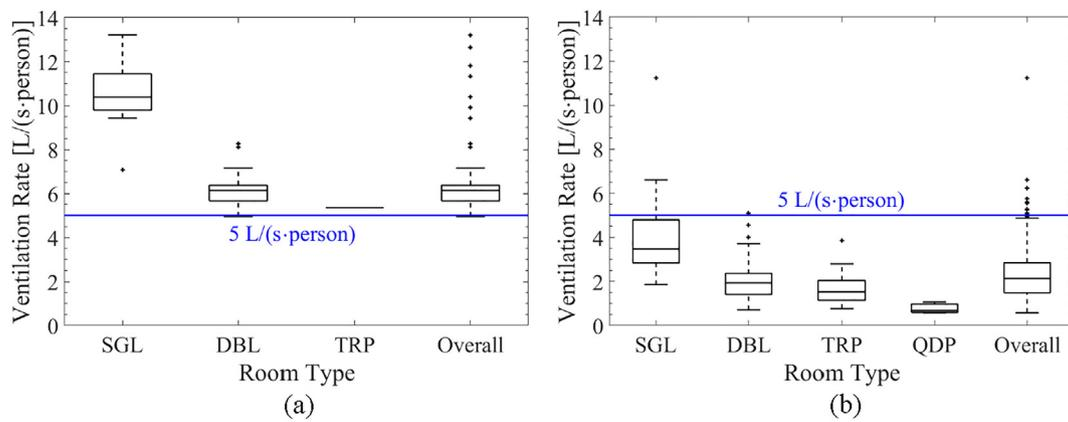

Fig. 9. Individual ventilation rates in: (a) HVB; and (b) LVB, where, SGL, DBL, TRP, and QDP denote single, double, triples, and quadruple rooms, respectively.

was in the HVB and two were in the LVB, occurred in the rooms with an individual ventilation rate greater than 5 L/s person.

In the LVB, 34% double rooms, 25% triple rooms and 40% quadruple rooms had confirmed ARI cases. There were only two single rooms among the participant rooms in LVB; therefore, the data could not provide statistically meaningful information for this room type. Moreover, as summarized in Table 3, there were 4% more participant rooms at the LVB leeward side to have ARI cases; and ARI cases occurred for the participants living at the leeward side were nearly twice of ARI cases at the windward side of the building. As a result, ARI rate in person-year was greater in the leeward side of LVB.

3.5. Impacts of door/window opening on room ventilation rates in LVB

To analyze the impact of door and window opening, we used questionnaire data supplied by cases and contacts as described in methods. A total of 79 building occupants, 4 in the HVB and 75 in the LVB, completed the door/window questionnaire at least once. Overall, 56 were cases undergoing in-depth evaluation (1 in the HVB and 55 in the LVB) and 56 were contacts named by cases (3 in the HVB and 53 in the LVB). Roommates of ARI cases accounted for a total of 32 of the respondents, one participant in the HVB and 31 in the LVB. However, only 25 participants, 2 in the HVB and 23 in the LVB, filled in the survey every day when they participated. Moreover, of these 25 participants, merely 20 living in the LVB reported significant use of open windows/door to their rooms. The increase of room ventilation rates due to door/window opening in these 20 dormitory rooms in the LVB were calculated with the multi-zone model with open airflow paths. The results are illustrated in Fig. 10.

As shown in Fig. 10, infiltration ventilation was apparently

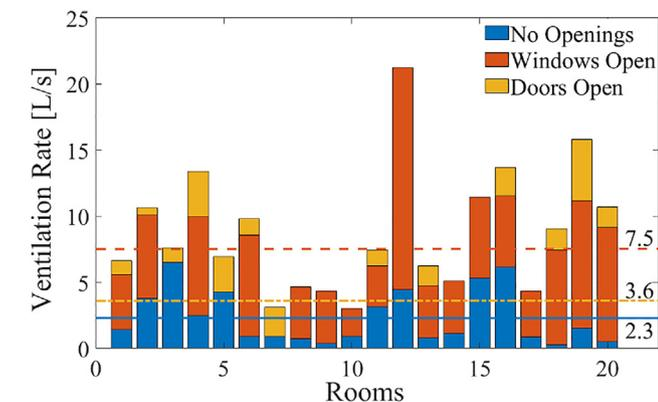

Fig. 10. Ventilation rate under different window/door opening scenarios in 20 LVB dormitory rooms, where horizontal lines represent averaged values.

enhanced by opening doors and windows, especially by opening windows which directly introduced outdoor air into the rooms. Average ventilation rate of twenty rooms increased from 2.3 L/s with no openings to 7.5 L/s by opening windows, 3.6 L/s by opening doors, and 8.8 L/s by opening both windows and doors. Most notable is Room 12, which has three windows while majority of other rooms have only one, and therefore experienced a very large increase (17.0 L/s) in ventilation, when they were all opened.

The sizeable increase in ventilation due to this minimal open airflow path change indicates the effectiveness of infiltration ventilation in the LVB. The issue with relying on this type of ventilation is the seasonal variation in window usage. Students were less likely to have their window open in January, February, and March, i.e. during the winter respiratory virus season (“flu season”), likely due to the low temperature outside. Therefore, it can be assumed that infiltration of outside air through the window leakage is a small percentage of a room’s ventilation during the majority of the ARI surveillance period.

3.6. LVB cluster of influenza a

This study examined a potential airborne cross-contamination for a pair of participants who were diagnosed with influenza A H3 virus infection on two consecutive days. Fig. 12 shows a section of the LVB floor plan; rooms with cases of influenza A were denoted using “*” symbol. In this case study, the initial identification of an influenza A virus infection occurred for a participant living in room RM5, while the participant volunteered for screening because of symptoms; a participant living in MR3 volunteered because of symptoms and was identified as infected with the same subtype of influenza one day after. To examine whether the case in RM3 could have been infected via viral aerosol movement between rooms, an aerobiologic pathway between rooms was investigated by simulating the spread of influenza A virus from RM5, using the calibrated multi-zone model with closed airflow paths for the LVB and the fine particle aerosol shedding rate of the case in RM5.

Fig. 11 shows the concentrations of viral aerosols in RM5 and RM3 during the simulation period. In both RM5 and RM3 room, the concentrations of viral aerosols reached the steady state 6 h after the release. The residents living in RM3 were exposed to the increasing concentration of influenza A virus during the nighttime on February 5th. And in the following days, they would continuously be exposed to the viral aerosol from RM5 at a concentration of around 0.05 viral RNA/m³ when they were in their room.

Fig. 12 presents the airflows between the zones and modeled RNA-copy concentrations in RM3, RM5, and their neighboring zones, after 8-hour simulation period. To illustrate importance of local airflow patterns, Fig. 12(a) shows the airflow map between the zones and RNA-copy concentrations in RM3, RM5, and their neighboring zones.

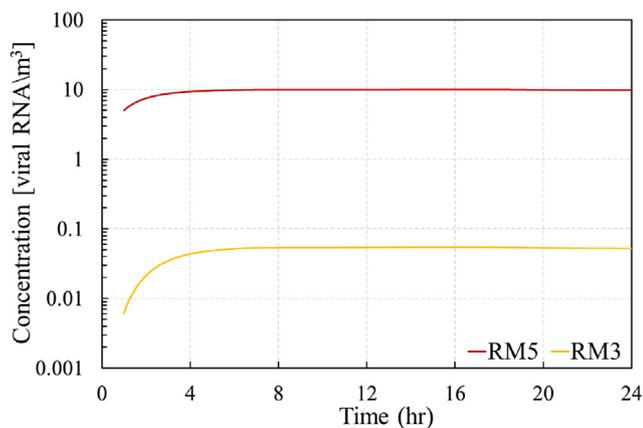

Fig. 11. Influenza A virus concentrations in room RM3 and RM5 during February 5th.

To illustrate importance and complexity of local airflow patterns, Fig. 12(a) presents the airflows coming in and going out of each room. All of the rooms, except for RM3, had airflows moving toward the hallway. Air entering RM3 from the outside, RM2, and the hallway exited by infiltrated into the bathroom (RM4) through wall leakage and then was sent outside by the exhaust fan located in the bathroom and denoted as F1 in Fig. 12. As a result, RM3 was unique, the only dormitory room on the hallway that had an aerobiologic pathway connecting it to RM5 (RM5 → Hallway → RM3, Fig. 11), with an estimated viral aerosol concentration of 0.05 viral RNA/m³.

Elevated virus concentrations were calculated for hallway (0.23 viral RNA/m³), bathroom (RM4) (0.17 viral RNA/m³) and janitor's closet (2.9 viral RNA/m³) 8 h after the release of viral aerosols. However, janitor's closet was unoccupied, air in the bathroom was directed to the exhausting fan installed at the ceiling, and residents typically spent limited time in both bathroom and hallway. Therefore, the total exposure to influenza A virus should be minimal in these zones. Importantly, during the night, residents in RM3 were continuously being exposed to viral aerosols for many hours. Using exposure times of 5 min in the hallway, 15 min in the bathroom, and 11 h in RM3 (as reported on a questionnaire collected on the day of infection detection) and pulmonary ventilation rates of 10 L/min walking in the hallway, 8 L/min in the bathroom, and 6 L/min while sleeping, the expected exposure in the hall and bathroom would be 5.4% and 9.3% of that overnight in RM3, respectively, if using the concentrations given above.

4. Discussion

These study results demonstrated that multi-zone modeling of large college residence hall can provide a means of realistically characterizing exposures to viral aerosols and identifying aerobiologic pathways for infection transmission between rooms in a naturally ventilated building. A key finding is that merely identifying occupants of neighboring rooms is not sufficient to characterize exposure and risk. These results clearly demonstrate the strengths of the model in its ability to identify and provide a quantitative estimate of exposure to distant-source viral aerosols within the residence hall. In the current model, however, the estimated exposure to infectious aerosols transported across the hallway were minimal and the cases identified each other as social contacts. Thus, distant-source bioaerosol may be a less likely pathway for transmission between the pair of cases described here. Interestingly, the second case in the pair was observed to be shedding > 10⁴ RNA copies/h, but no secondary cases were observed. In terms of infecting persons in neighboring rooms via distant-source aerosols, none would have been expected given the airflow map described (Fig. 12). Finally, our finding of a strong trend toward increased ARI incidence associated with ventilation rates of less than 5 L/(s person) suggests that very low outdoor air supply rates may be impacting ARI, either by promoting transmission via bioaerosols within the building or by altering host susceptibility to infection.

4.1. Reasonability to ignore infection risk in other public indoor spaces

People getting infected is a result from cumulative exposure to infectious viruses (Kuster et al., 2011). In addition, many factors, such as the susceptibility to infectious virus (Quiñones-Parra et al., 2016), can affect the occurrence of infection. It is actual that the students might finally get infected in a classroom, in a bus, in a restaurant, or somewhere else. However, if a student was frequently exposed to the same virus in several indoor settings right before getting infected, it was impossible to figure out the exact location for the student to get infected. Specifically, in this study, we ignored the potential for infection transmission in other public indoor spaces, such as classrooms, restaurant, buses, etc., when comparing ARI risk in the two buildings, and investigating ventilation impact on ARI risk, for the following reasons:

- (1) ARI rate was very low in the HVB. This result also implied a low infection risk in other indoor settings because the HVB residents experienced the same public indoor spaces as the LVB residents.
- (2) The students might meet in other public indoor spaces as listed above, but only the dormitory buildings presented the students

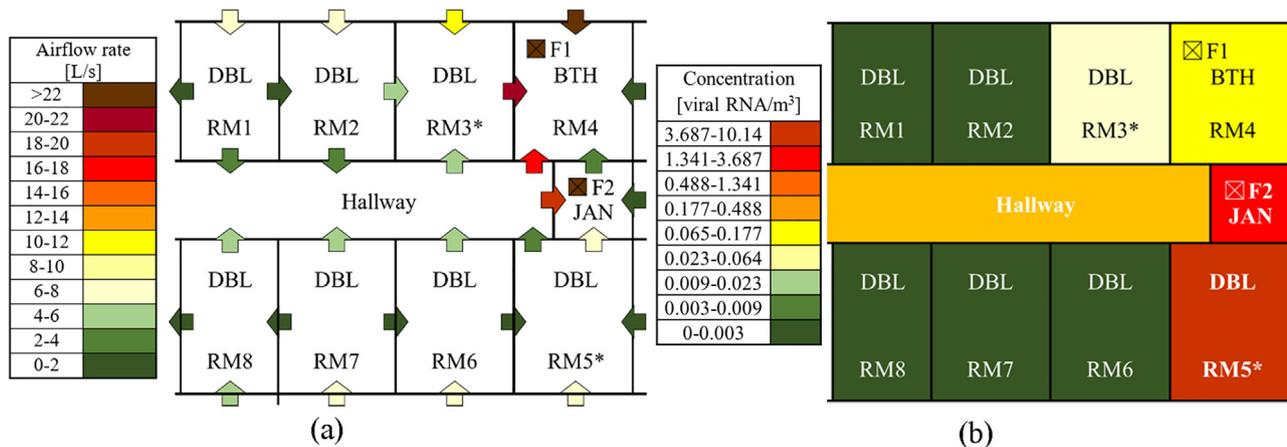

Fig. 12. Concentration distribution of bioaerosols carrying influenza A viruses 8 h after the release in the source room RM5: (a) airflow map with a linear scaling; and (b) concentration distribution of influenza A virus with logarithmic scaling, where DBL denotes double room, BTH denotes bathroom, JAN denotes the janitor's closet, * denotes the room with influenza infections, F1 and F2 are two exhaust fans with an airflow rate of 72.2 L/s and 24.1 L/s, respectively.

completely different ventilation conditions. In other words, among the daily experienced public indoor spaces, only the dormitory buildings provided their residents unique ventilation conditions significantly different to each other.

- (3) The students frequently switched their locations they were not in the dormitory buildings. Compared to other public indoor spaces, dormitory building provided the students much longer and more stable exposure to infectious viruses.
- (4) According to the survey data, the students reported illness at some point spent more time in the dormitory buildings than those who did not. This could potentially cause infection risk increased in the dormitory buildings, and reduced in other public indoor spaces.

4.2. Improving ventilation for the LVB building

Opening windows can increase LVB room ventilation rate to the levels comparable to ventilation rates in HVB rooms. Therefore, opening windows is an effective measure to improve room ventilation in the LVB. Unfortunately, opening windows is not a viable option most of time during the flu season due to thermal comfort issue that cold outdoor air could create in these rooms. On the other side, for a building with a central air-conditioning system for temperature control, such low infiltration results from intensive high insulation designed to achieve energy savings. From the same perspective, simply opening windows is not a good option for the buildings like the LVB in the flu season.

The investigation also confirmed the influences of outdoor wind conditions on room ventilation and identified a trend toward an association of occupancy rates with increased ARI rates in the LVB. Both ventilation and ARI rates were found to be worst in quadruple rooms although these rooms have the largest floor areas and room volumes. These rooms had a decreased ACH with the increase in room volume, because the outside airflow rate primarily depended on the window and wall crack sizes. The reduction in individual ventilation rate along with the increase in room occupancy was most evident in quadruple rooms. Triple rooms had individual ventilation rate comparable to those in double rooms. This may have been related to having window and wall surfaces located at the windward side of the LVB building, and accounted for the trend toward lower ARI attack rates in the triples. Accordingly, locating triple and quadruple rooms at the windward side of LVB-like buildings could improve ventilation within the constraints of the building's capacity.

4.3. Limitations of the current study

The study has several limitations with respect to establishing a quantitative relationship between the ventilation rate and ARI incidence, even though a strong trend was observed. These limitations include inherent sample biases in prediction of ventilation rate and observation of ARI incidence. In terms of prediction of ventilation rate, the timing of door/window opening is important. However, this study did not have sufficient data from a sufficiently wide selection of rooms to approximate ventilation on a typical schedule of student door/window opening habits for all of the rooms. Moreover, the questionnaire about door/window opening was only administered to cases on the day and the days following ARI diagnosis and to contacts of cases on up to seven consecutive days of follow-up. Therefore, with the available survey data, it is not possible to predict an average student schedule of opening windows throughout the flu season. It would be possible to predict these schedules from CO₂ sensors, but these two buildings were only partially instrumented. Sensor maintenance took place only once or twice during the flu season due to limited room access required by campus residential policies and regulations. As a result, the room coverage rate with CO₂ sensors was 32% in HVB, and 24% in LVB; there rooms were used as representative samples for these two buildings. The model prediction can be further improved by

collecting additional CO₂ data in the dormitory rooms. Alternatively, the administration of the door/window opening questionnaire to cases and contacts ensured data collection on these critical factors focused on the most critical exposure events, allowing the highest confidence for estimating room-to-room airflow pattern during the relevant time windows. In the future, to remedy the limitation of survey investigation regarding subject and time period selections, we will consider to use motion sensors to record the operation of doors and windows. Such technology can be expected to provide accurate and detailed schedules for door and window opening for all of the rooms of interest during the experimental period.

In terms of ARI incidence, loss of power and potential bias may have been introduced from the skewed participation rates among occupants of the two buildings: 5% in the HVB, and 20% in the LVB. The paucity of person-time contributed by HVB occupants resulted in wide confidence limits and a lack of statistical significance even though the incidence rate ratio was large. Furthermore, we cannot exclude the possibility that the few participants in the HVB were less likely to report symptoms and volunteer for testing than the participants in the LVB where overall participation rate was higher. We note that the HVB residents were students with expressed interest in engineering programs while the LVB residents were students with expressed interest in life sciences and public health. Whether these typical interests are associated with propensity to participate in the study and report illness is unclear. However, these considerations point to a potential for a bias toward overestimating the impact of ventilation and a need to identify methods to increase participation among HVB occupants. Randomization of building assignment so that life science and public health students are not assigned to the LVB every year has not been deemed feasible.

Further work will use deep sequencing of viruses for genetic confirmation of transmission events and counterfactual analyses to test for a causal impact of ventilation on risk of transmission. Transmission at a distance to occupants of neighboring rooms where there is an identifiable aerobiologic pathway (as seen here), when the neighbors are not close social contacts (in contrast to the cases described here) would provide the strongest evidence that a ventilation effect on transmission risk was due to reduced risk of airborne transmission. Alternatively, low ventilation could, in addition to being associated with non-specific building related symptoms, cause increased rates of ARI through a causal impact on host susceptibility to infection. The capability demonstrated here to identify and quantify aerobiologic pathways between rooms will be critical to unravelling these competing, and potentially co-existing effects of ventilation on building occupant health.

The uncertainty of a) ventilation measurements due to incomplete coverage of the buildings with CO₂ sensors and b) ARI incidence due to low participation rates in the HVB, both contribute to random measurement error. The errors in the ventilation measurements are likely mostly non-differential and bias toward to null. However, the limited person-time from HVB, which clearly limited power, may have been accompanied by a bias toward finding an effect of ventilation. Nevertheless, these data demonstrate that a rigorous approach to identifying and validating the impact of ventilation on ARI incidence is uniquely possible in this environment.

5. Conclusions

This study experimentally investigated CO₂ variations in two dormitory buildings, i.e. HVB and LVB, and developed calibrated multi-zone models to calculate ventilation rates during an entire flu season. These models also calculated the potential for transport of influenza A viral aerosols between adjacent dormitory rooms and the concentrations and exposures expected for room occupants. According to the results, CO₂ average concentration was 1230 ± 408 ppm in the HVB and 1492 ± 837 ppm in the LVB. Both room and individual ventilation rates in HVB were three times the amount of ventilation in LVB. This

difference between ventilation rates in the two dormitory buildings might be overestimated, because the simulations applied closed airflow paths throughout the whole studied period. Nevertheless, in this study, an individual ventilation of 5 L/(s person) distinguished high ventilation and low ventilation buildings.

A strong trend toward high ARI incidence associated with low outdoor air supply rates was observed. Additional years of monitoring with randomization of academic programs across buildings from year-to-year and/or improved recruitment and retention methods are needed to confirm the findings regarding the impact of ventilation on ARI. Additional studies, easily nested in the current design, will be needed to identify whether an impact of ventilation, if confirmed, is a result of increased transmission risk or altered host susceptibility.

Opening windows was actually an effective measure to increase infiltration ventilation to the rates typically produced by mechanical system, but this measure is not practical during the cold months of the flu season in the northern hemisphere. Thus, alternative measures, such as careful placement of triple and quadruple dormitory rooms and possibly dividing some quads could be explored for impact on ventilation. Importantly, a case study on the cross-contamination of influenza A virus shows that airborne transmission needs to be analyzed based on the detailed airflow map, rather than the spatial relationship between the rooms. Overall, occupants in poorly ventilated buildings, such as the LVB, may have to play an active role in ensuring adequate ventilation and reducing their risk of suffering from ARIs.

CRedit authorship contribution statement

Shengwei Zhu: Investigation, Data curation, Methodology, Formal analysis, Writing - original draft, Writing - review & editing, Visualization. **Sara Jenkins:** Investigation, Formal analysis, Writing - original draft, Visualization. **Kofi Addo:** Investigation, Formal analysis, Writing - review & editing. **Mohammad Heidarinejad:** Methodology, Investigation, Software, Formal analysis, Writing - review & editing. **Sebastian A. Romo:** Software, Investigation, Formal analysis, Writing - review & editing, Visualization. **Avery Layne:** Methodology, Investigation. **Joshua Ehizibolo:** Investigation, Formal analysis. **Daniel Dalgo:** Methodology, Investigation. **Nicholas W. Mattise:** Methodology, Investigation. **Filbert Hong:** Data curation, Investigation, Writing - review & editing, Project administration. **Oluwasanmi O. Adeniyi:** Investigation, Formal analysis, Writing - original draft, Writing - review & editing. **P. Jacob Bueno de Mesquita:** Investigation, Formal analysis, Writing - review & editing. **Barbara J. Albert:** Investigation. **Rhonda Washington-Lewis:** Investigation. **Jennifer German:** Investigation, Formal analysis. **S.-H. Sheldon Tai:** Investigation, Formal analysis. **Somayeh Youssefi:** Investigation. **Donald K. Milton:** Conceptualization, Investigation, Formal analysis, Writing - review & editing, Supervision, Project administration, Funding acquisition. **Jelena Srebric:** Conceptualization, Investigation, Methodology, Formal analysis, Writing - original draft, Writing - review & editing, Supervision, Project administration, Funding acquisition.

Declaration of Competing Interest

The authors declare that they have no known competing financial interests or personal relationships that could have appeared to influence the work reported in this paper.

Acknowledgement

This study is part of Prometheus-UMD, which was sponsored by the Defense Advanced Research Projects Agency (DARPA) BTO under the auspices of Col. Matthew Hepburn through agreement [N66001-18-2-4015]. The findings and conclusions in this report are those of the authors and do not necessarily represent the official position or policy

of the funding agency and no official endorsement should be inferred. We also thank William S. Dols from National Institute of Standards and Technology (NIST), for his help in multizone modeling. The research team appreciates the support of UMD Residential Facilities in accessing the student population and buildings.

Appendix A. Supplementary data

Supplementary data to this article can be found online at <https://doi.org/10.1016/j.envint.2020.105537>.

References

- Armbruster, D.A., Pry, T., 2008. Limit of blank, limit of detection and limit of quantitation. *Clin. Biochem. Rev.* 29 (Suppl 1), S49–S52 PMID: 18852857.
- ASHRAE, 2002. ASHRAE Guideline 14-2002: Measurement of energy and demand savings. American Society of Heating, Refrigerating and Air-Conditioning Engineers, Atlanta.
- Ayompe, L.M., Duffy, A., McCormack, J., Conlon, M., 2011. Validated TRNSYS model for forced circulation solar water heating systems with flat plate and heat pipe evacuated tube collectors. *Appl. Therm. Eng.* 31, 1536–1542.
- Brundage, J.F., Scott, R.M., Lednar, W.M., Smith, D.W., Miller, R.N., 1988. Building-associated risk of febrile acute respiratory diseases in army trainees. *JAMA* 249 (14), 2108–2112. <https://doi.org/10.1001/jama.1988.03720140028029>.
- Bueno de Mesquita P.J., Heidarinejad M., Addo K., Dalgo, D., Mattise N., Srebric J., Milton D.K., 2018. Estimating exposure to infectious influenza aerosols in roommates of influenza cases during the 2012–2013 season on the University of Maryland campus. In: *Indoor Air 2018*. Philadelphia, PA, USA, July 22–27.
- Cohen, S., Kamarck, T., Mermelstein, R., 1983. A global measure of perceived stress. *J. Health Soc. Behav.* 24 (4), 385–396. <https://doi.org/10.2307/2136404>.
- Cowling B.J., Ip D.K.M., Fang V.J., Suntarattiwong P., Olsen S.J., Levy J., Uyeki T.M., Leung G.M., Malik Peiris J.S., Chotpitayasunondh T., Nishiura H., Simmerman J.M., 2013. Aerosol transmission is an important mode of influenza A virus spread. *Nat. Commun.* 4, 1935. DOI: 10.1155/2013/493960.
- Dols W.S., Polidoro B.J., 2015. NIST Technical Note 1887: CONTAM User Guide and Program Documentation Ver. 3.2. National Institute of Standards and Technology, Gaithersburg, MD. DOI: 10.6028/NIST.TN.1887.
- Ghosh, B., Lal, H., Srivastava, A., 2015. Review of bioaerosols in indoor environment with special reference to sampling, analysis and control mechanisms. *Environ. Int.* 85, 254–272. <https://doi.org/10.1016/j.envint.2015.09.018>.
- Harvey, J.J., Chester, S., Burke, S.A., Ansbros, M., Aden, T., Gose, R., Sciuilli, R., Bai, J., DesJardin, L., Benfer, J.L., Hall, J., Smole, S., Doan, K., Popowich, M.D., George, K.S., Quinlan, T., Halse, T.A., Li, Z., Pérez-Osorio, A.C., Glover, W.A., Russell, D., Reisdorf, E., Whyte Jr., T., Whitaker, B., Hatcher, C., Srinivasan, V., Tatti, K., Lucia, Tondella M., Wang, X., Winchell, J.M., Mayer, L.W., Jernigan, D., Mawle, A.C., 2016. Comparative analytical evaluation of the respiratory TaqMan Array Card with real-time PCR and commercial multi-pathogen assays. *J. Virol. Methods* 228, 151–157. <https://doi.org/10.1016/j.jviromet.2015.11.020>.
- Heidarinejad M., Addo K., Dalgo D., Mattise N.W., Milton D.K., Srebric J. Carbon dioxide patterns in a student dormitory rooms monitored for influenza transmissions. In: *Indoor Air 2018*. Philadelphia, PA, USA, July 22–27.
- Hoge, C.W., Reichler, M.R., Dominguez, E.A., Brerner, J.C., Mastro, T.D., Hendricks, K.A., Musher, D.A., Elliott, J.O., Facklam, R.D., Breiman, R.F., 1994. An epidemic of pneumococcal disease in an overcrowded, inadequately ventilated jail. *N Engl J Med.* 331, 643–648.
- Jaremit, D., Srebric, J., 2015. A characterization of time-dependent air infiltration rates in retail stores using calibrated multi-zone model. *Sci. Technol. Built Environ.* 21 (4), 420–428. <https://doi.org/10.1080/23744731.2015.1006508>.
- Kuster, S.P., Shah, P.S., Coleman, B.L., Lam, P.-P., Tong, A., Wormsbecker, A., McGeer, A., 2011. Incidence of influenza in healthy adults and healthcare workers: a systematic review and meta-analysis. *PLoS One* 6 (10), e26239. <https://doi.org/10.1371/journal.pone.0026239>.
- La Rosa, G., Fratini, M., Della Libera S., Iaconelli, M., Muscillo, M., 2013. Viral infections acquired indoors through airborne, droplet, or contact transmission. *Ann. Ist. Super. Sanità.* 49 (2), 124–132. <https://doi.org/10.4415/ANN.13.02.03>.
- Lopez-Coto, O., Ghosh, S., Prasad, K., Whetstone, J., 2017. Tower-based greenhouse gas measurement network design – The National Institute of Standards and Technology North East Corridor Testbed. *Adv. Atmos. Sci.* 34 (9), 1095–1105. <https://doi.org/10.1007/s00376-017-6094-6>.
- Li, Y., Leung, G.M., Tang, J.W., Yang, X., Chao, C.Y.H., Lin, J.Z., Lu, J.W., Nielsen, P.V., Niu, J., Qian, H., Sleigh, A.C., Su, H.-J.J., Sundell, J., Wong, T.W., Yuen, P.L., 2007. Role of ventilation in airborne transmission of infectious agents in the built environment – a multidisciplinary systematic review. *Indoor Air* 17, 2–18. <https://doi.org/10.1111/j.1600-0668.2006.00445.x>.
- Lindsay, W.G., Pearce, T.A., Hudnall, J.B., Davis, K.A., Fisher, M.A., Khakoo, R., Palmer, J.E., Clark, K.E., Celik, I., Coffey, C.C., Blachere, F.M., Beezhold, D.H., 2012. Quantity and size distribution of cough-generated aerosol particles produced by influenza patients during and after illness. *J. Occup. Environ. Hyg.* 9 (7), 443–449. <https://doi.org/10.1080/15459624.2012.684582>.
- McDevitt, J.J., Kouttrakis, P., Ferguson, S.T., Wolfson, J.M., Patricia, Fabian M., Martins, M., Pantelic, J., Milton, D.K., 2013. Development and performance evaluation of an exhaled-breath bioaerosols collector for influenza virus. *Aerosol Sci. Tech.* 47 (4),

- 444–451. <https://doi.org/10.1080/02786826.2012.762973>.
- Milton, D.K., Patricia, Fabian M., Cowling, B.J., Grantham, M.L., McDevitt, J.J., 2013. Influenza virus aerosols in human exhaled breath: particle size, culturability, and effect of surgical masks. *PLoS Pathog.* 9 (3), e1003205. <https://doi.org/10.1371/journal.ppat.1003205>.
- Mumma, S.A., 2001. Designing dedicated outdoor air systems. *ASHRAE J.* May, 28–31.
- Myatt, T.A., Johnston, S.L., Zuo, Z.F., Wand, M., Kebabdz, T., Rudnick, S., Milton, D.K., 2004. Detection of airborne rhinovirus and its relation to outdoor air supply in office environments. *Am. J. Respir. Crit. Care. Med.* 169, 1187–1190. <https://doi.org/10.1164/rccm.200306-7600C>.
- Nardell, E.A., Keegan, J., Cheney, S.A., Etkind, S.C., 1991. Airborne infection. Theoretical limits of protection achievable by building ventilation. *Am. Rev. Respir. Dis.* 144 (2), 302–306. <https://doi.org/10.1164/ajrccm/ajrccm/144/2/302>.
- Noti, J.D., Lindsley, W.G., Blachere, F.M., Cao, G., Kashon, M.L., Thewlis, R.E., McMillen, C.M., King, W.P., Szalajda, J.V., Beezhold, D.H., 2012. Detection of infectious influenza virus in cough aerosols generated in a simulated patient examination room. *Clin. Infect. Dis.* 54 (11), 1569–1577.
- Persily A.K., Ivy E.M., 2001. NISTIR 6585. Input data for multizone airflow and IAQ analysis. National Institute of Standards and Technology, Gaithersburg, MD.
- Persily, A., de Jonge, L., 2017. Carbon dioxide generation rates for building occupants. *Indoor Air* 27 (5), 868–879. <https://doi.org/10.1111/ina.12383>.
- Quiñones-Parra, S.M., Clemens, E.B., Wang, Z., Croom, H.A., Kedzierski, L., McVernon, J., Vijaykrishna, D., Kedzierska, K., 2016. A role of influenza virus exposure history in determining pandemic susceptibility and CD8⁺ cell responses. *J. Virol.* 90, 6939–6947. <https://doi.org/10.1128/JVI.00349-16>.
- Riley, E.C., Murphy, G., Riley, R.L., 1978. Airborne spread of measles in a suburban elementary school. *Am. J. Epidemio.* 107 (5), 421–432.
- Rudnick, S.N., Milton, D.K., 2003. Risk of indoor airborne infection transmission estimated from carbon dioxide concentration. *Indoor Air* 13, 237–245. <https://doi.org/10.1034/j.1600-0668.2003.00189.x>.
- Srebric, J., Yuan, J., Novoselac, A., 2008. In-situ experimental validation of a coupled multi-zone and CFD model for building contaminant transport simulations. *ASHARE Trans.* 114 (1), 273–281.
- Steensels, D., Reynders, M., Descheemaeker, P., Curran, M.D., Jacobs, F., Denis, O., Delforge, M.-L., Montesinos, I., 2015. Clinical evaluation of a multi-parameter customized respiratory TaqMan® array card compared to conventional methods in immunocompromised patients. *J. Clin. Virol.* 72, 36–41. <https://doi.org/10.1016/j.jcv.2015.08.022>.
- Sun, Y.X., Wang, Z.G., Zhang, Y.F., Sundell, J., 2011. In China, students in crowded dormitories with a low ventilation rate have more common colds: evidence for airborne transmission. *PLoS ONE* 6 (11), e27140. <https://doi.org/10.1371/journal.pone.0027140>.
- Tang, J.W., Li, Y., Eames, I., Chang, P.K., Ridgway, G.L., 2006. Factors involved in the aerosol transmission of infection and control of ventilation in healthcare premises. *J. Hosp. Infect.* 64 (2), 100–114. <https://doi.org/10.1016/j.jhin.2006.05.022>.
- Tellier, R., 2009. Aerosol transmission of influenza A virus: a review of new studies. *J. R. Soc. Interface* 6, S783–S790. <https://doi.org/10.1098/rsif.2009.0302.focus>.
- Wells, W.F., 1955. *Airborne contagion and air hygiene: an ecological study of droplet infection.* Harvard University Press, Cambridge, MA.
- Wu, X., Lu, Y.M., Zhou, S., Chen, L.F., Xu, B., 2016. Impact of climate change on human infectious diseases: empirical evidence and human adaptation. *Environ. Int.* 86, 14–23. <https://doi.org/10.1016/j.envint.2015.09.007>.
- Wu, Y., Niu, J., Liu, X., 2018. Air infiltration induced inter-unit dispersion and infectious risk assessment in a high-rise residential building. *Build. Simul.* 11 (1), 193–202. <https://doi.org/10.1007/s12273-017-0388-6>.
- Yan J., Grantham M., Pantelic J., Bueno de Mesquita P.J., Albert B., Liu F.J., Ehrman S., Milton D.K., Consortium E., 2018. Infectious virus in exhaled breath of symptomatic seasonal influenza cases from a college community. *PNAS.* 115(5), 1081–1086. DOI: 10.1073/pnas.1716561115.
- Yu, I.T.S., Li, Y., Wong, T.W., Tam, W., Chan, A.T., Lee, J.H.W., Leung, D.Y.C., Ho, T., 2004. Evidence of airborne transmission of the severe acute respiratory syndrome virus. *N. Engl. J. Med.* 350, 1731–1739. <https://doi.org/10.1056/NEJMoa032867>.
- Zhao, M.J., Kim, Y.S., Srebric, J., 2015. Occupant perceptions and a health outcome in retail stores. *Build. Environ.* 93, 385–394. <https://doi.org/10.1016/j.buildenv.2015.05.039>.
- Zhu, S., Srebric, J., Spengler, J.D., Demokritou, P., 2012. An advanced numerical model for the assessment of airborne transmission of influenza in bus microenvironments. *Build. Environ.* 47, 67–75. <https://doi.org/10.1016/j.buildenv.2011.05.003>.
- Zhu, S., Srebric, J., Rudnick, S.N., Vincent, R.L., Nardell, E.A., 2013. Numerical investigation of upper-room UVGI disinfection efficacy in an environmental chamber with a ceiling fan. *Photochem. Photobiol.* 89, 782–791. <https://doi.org/10.1111/php.12039>.