



Since January 2020 Elsevier has created a COVID-19 resource centre with free information in English and Mandarin on the novel coronavirus COVID-19. The COVID-19 resource centre is hosted on Elsevier Connect, the company's public news and information website.

Elsevier hereby grants permission to make all its COVID-19-related research that is available on the COVID-19 resource centre - including this research content - immediately available in PubMed Central and other publicly funded repositories, such as the WHO COVID database with rights for unrestricted research re-use and analyses in any form or by any means with acknowledgement of the original source. These permissions are granted for free by Elsevier for as long as the COVID-19 resource centre remains active.



# Conversion of operating theatre from positive to negative pressure environment

T.T. Chow <sup>a,\*</sup>, A. Kwan <sup>b</sup>, Z. Lin <sup>a</sup>, W. Bai <sup>a</sup>

<sup>a</sup> *Division of Building Science & Technology, City University of Hong Kong, Hong Kong SAR, China*

<sup>b</sup> *Department of Anaesthesiology, United Christian Hospital, Hong Kong SAR, China*

Received 24 November 2005; accepted 7 July 2006

Available online 14 October 2006

## KEYWORDS

Operating theatre;  
Airflow performance;  
Airborne infection

**Summary** The severe acute respiratory syndrome (SARS) crisis led to the construction of a negative pressure operating theatre at a hospital in Hong Kong. It is currently used for treatment of suspected or confirmed airborne infection cases, and was built in anticipation of a return of SARS, an outbreak of avian influenza or other respiratory epidemics. This article describes the physical conversion of a standard positive pressure operating theatre into a negative pressure environment, problems encountered, airflow design, and evaluation of performance. Since entering regular service, routine measurements and observations have indicated that the airflow performance has been satisfactory. This has also been confirmed by regular air sampling checks. Computational fluid dynamics, a computer modelling technique, was used to compare the distribution of room air before and after the design changes from positive to negative pressure. The simulation results show that the physical environment and the dispersion pattern of bacteria in the negative pressure theatre were as good as, if not better than, those in the original positive pressure design.

© 2006 The Hospital Infection Society. Published by Elsevier Ltd. All rights reserved.

## Introduction

The severe acute respiratory syndrome (SARS) crisis in Hong Kong from March to June 2003 resulted in extreme stresses and strains on the general running of hospitals. Generally, SARS patients were accommodated in negative pressure isolation rooms on the ward. When these patients required operative procedures, a negative

\* Corresponding author. Address: Division of Building Science & Technology, City University of Hong Kong, Tat Chee Avenue, Kowloon, Hong Kong, China. Tel.: +852 2788 7622; fax: +852 2788 9716.

E-mail address: [bsttchow@cityu.edu.hk](mailto:bsttchow@cityu.edu.hk)

pressure theatre was considered to be more suitable than a positive pressure environment. In principle, a positive pressure operating theatre with adequate air changes could quickly eliminate the virus from the environment, and it has been shown that the risk of cross-contamination from airborne infection is low if staff are adequately protected with appropriate personal protective equipment (PPE).<sup>1</sup> However, a negative pressure operating theatre offers optimal protection to personnel working in adjacent areas.

Most SARS patients admitted to the United Christian Hospital during the crisis were residents of Amoy Gardens, where the largest transmission of community-acquired SARS occurred. Over a short period, one of the 11 operating theatres in the main operating suite of the hospital was converted temporarily into a negative pressure theatre. This was achieved by incorporating two strong exhaust fans next to the original exhaust system. The pressure differential was maintained by sealing the entrance doors with disposable sticky tape after the patient was transported into the room. This temporary negative pressure theatre worked well during the SARS crisis.<sup>2</sup> Afterwards, the hospital management decided that a permanent negative pressure operating theatre was necessary, in anticipation of SARS returning and for those patients contracting similar infectious airborne diseases such as tuberculosis and severe influenza. The construction of this permanent negative pressure operating theatre was completed in June 2004.

The original operating theatre suite in this hospital was built in 1994. Similar to all other operating theatres in Hong Kong around that period and up to the present day, the operating theatres were maintained at a positive pressure. Specifications such as the floor area, airflow quantity and pressure gradient were designed to meet the requirements of the British operating theatre standards, which have been commonly used as reference in Hong Kong.<sup>3,4</sup> The room pressure was maintained at +25 Pa. Areas around the operating theatre were also under positive pressure. By controlling the supply and extract airflow rates of each room in accordance with the design data given in [Figure 1](#), a pressure gradient was developed in continuous progression through zones with increasing sterility. Outside air was introduced to the operating theatre through a perforated diffuser at ceiling level, directly above the surgical area. This led to a downward displacement of air above the operating table. Room air was extracted through a low-level exhaust grill located next to the back door and an embedded exhaust duct in the sidewall.

This paper presents the process of converting a positive pressure theatre into a negative pressure theatre, and the subsequent performance evaluation.

## Methods

### Routine monitoring of airflow performance

The airflow system performance of an operating theatre in the hospital was monitored regularly through observations and/or measurements of pressure gradient, flow pattern, temperature and humidity levels. To ensure sterility in the operating theatre, routine bacterial sampling using two types of plates [tryptone soy agar (TSA) and Sabouraud agar] was performed after each air duct cleansing and filter replacement. The plates were placed in three positions (i.e. high, low and at the air exhaust). The high position was located by the anaesthesia apparatus near the operating table, 2 m above floor level; the low position was located near the operating table, 1 m above floor level; and the air exhaust position was in front of either of the exhaust grilles. The SAS Super 100 Air Sampler (International Pbi, Milano, Italy) was used to obtain volumes of 500 L into two separate 55-mm culture plates of TSA (Oxoid, Basingstoke, UK) and Sabouraud agar (bioMérieux, Marcy l'Étoile, France). The plates were incubated at 37 °C and 30 °C for two days and five days for bacterial and fungal counts, respectively. A colony count of less than 30 colony-forming units (CFU)/m<sup>3</sup> for the TSA agar and 3 CFU/m<sup>3</sup> for the Sabouraud agar was adopted as the acceptable standard in all operating theatres, but a more stringent standard was applied to the theatre using laminar airflow.<sup>5</sup>

### Theatre selection for negative pressure conversion

Theatre 1 (OT-1) of the main operating suite was chosen for pressure conversion for two main reasons. Firstly, OT-1 was the furthest away from the other operating theatres, making isolation easier to accomplish. It minimized the risk of air from the corridor being contaminated as a result of traffic flow and then being drawn into the negative pressure operating theatre, which could be a risk for wound infection. Secondly, it had two free sidewalls that could accommodate the addition of a separate exhaust system, and had its own scrub area and a separate induction room that could be converted into a room for removal of contaminated clothing. The main feature of the negative pressure

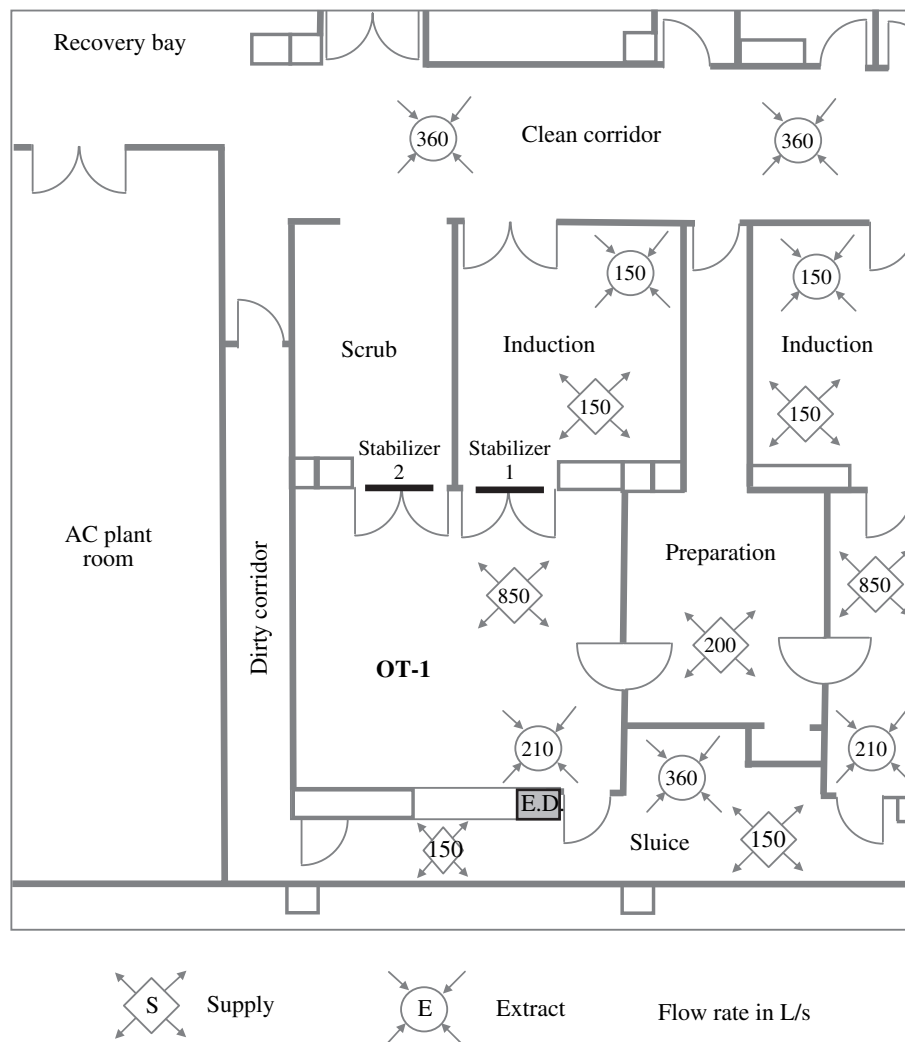

**Figure 1** Floor plan of operating theatre suite before pressure conversion. E.D., exhaust duct; OT-1, Operating Theatre 1; AC, air conditioning.

design, compared with the positive pressure design, was the incorporation of a much stronger low-level exhaust system. The exhaust air passed through a two-stage filtration system (prefilter plus High Efficiency Particulate Air (HEPA) filter) before its final disposal via an exhaust air fan. In order to achieve the designated airflow criteria, an ante-room was constructed at the front end of the scrub and induction rooms leading to OT-1. All doors leading to these negative pressure rooms were made airtight and interlocking. The physical layout and the airflow specification of the negative pressure operating theatre suite are shown in [Figure 2](#). As OT-1 and OT-2 originally shared the same air conditioning system, a separate air conditioning system had to be built for OT-2 before the necessary changes were made to OT-1.

Static pressure heads in OT-1 and in the adjacent rooms were monitored by differential pressure gauge measurements. Correct airflow velocities at

the supply diffuser and exhaust grilles were checked by vane anemometer measurements. The airflow pattern was examined carefully using smoke tests. In order to gather more technical information for assessing the effectiveness of the present airflow system, the room air distribution before and after the conversion was examined through computer analysis.

**Airflow evaluation by CFD technique**

Computational fluid dynamics (CFD) analysis provides comprehensive data on airflows within a room. It demonstrates any deficiencies in air distribution and in contaminant removal. It has been applied to the study of airflows and contaminant distribution patterns in various operating theatre applications.<sup>6-10</sup>

In this study, the computation models of Cases A and B, i.e. before and after the pressure

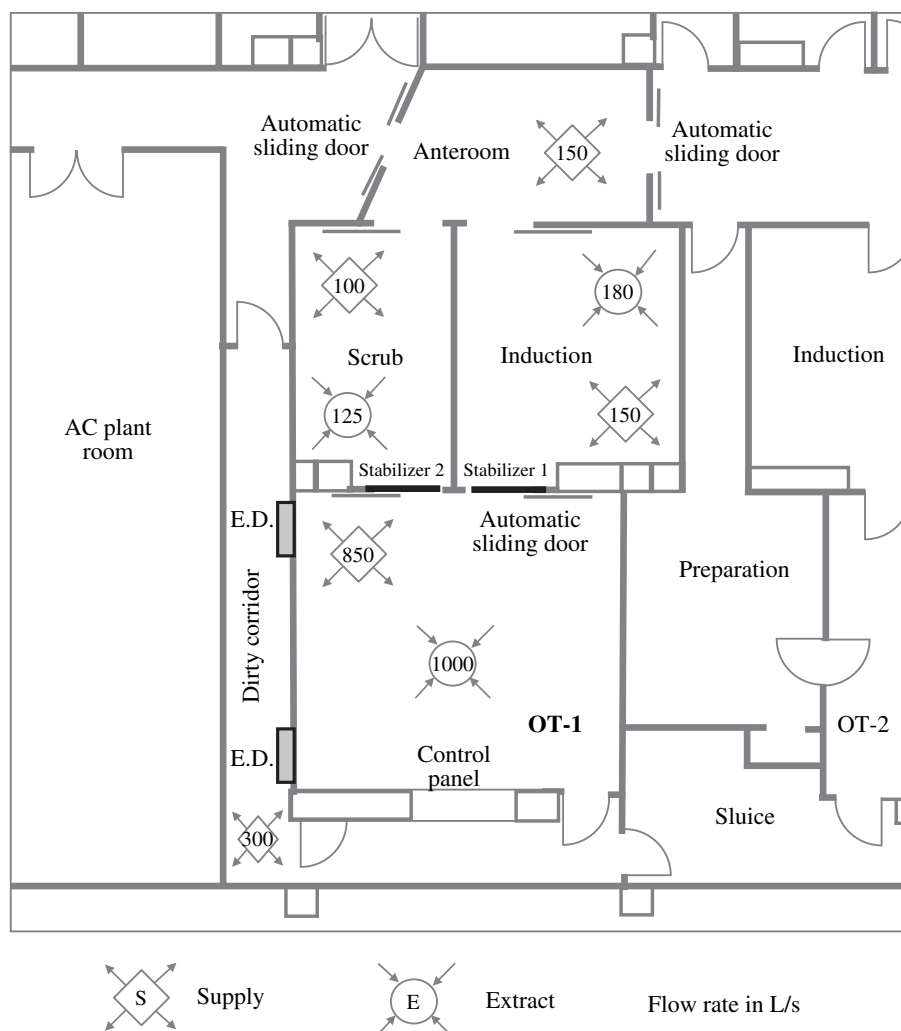
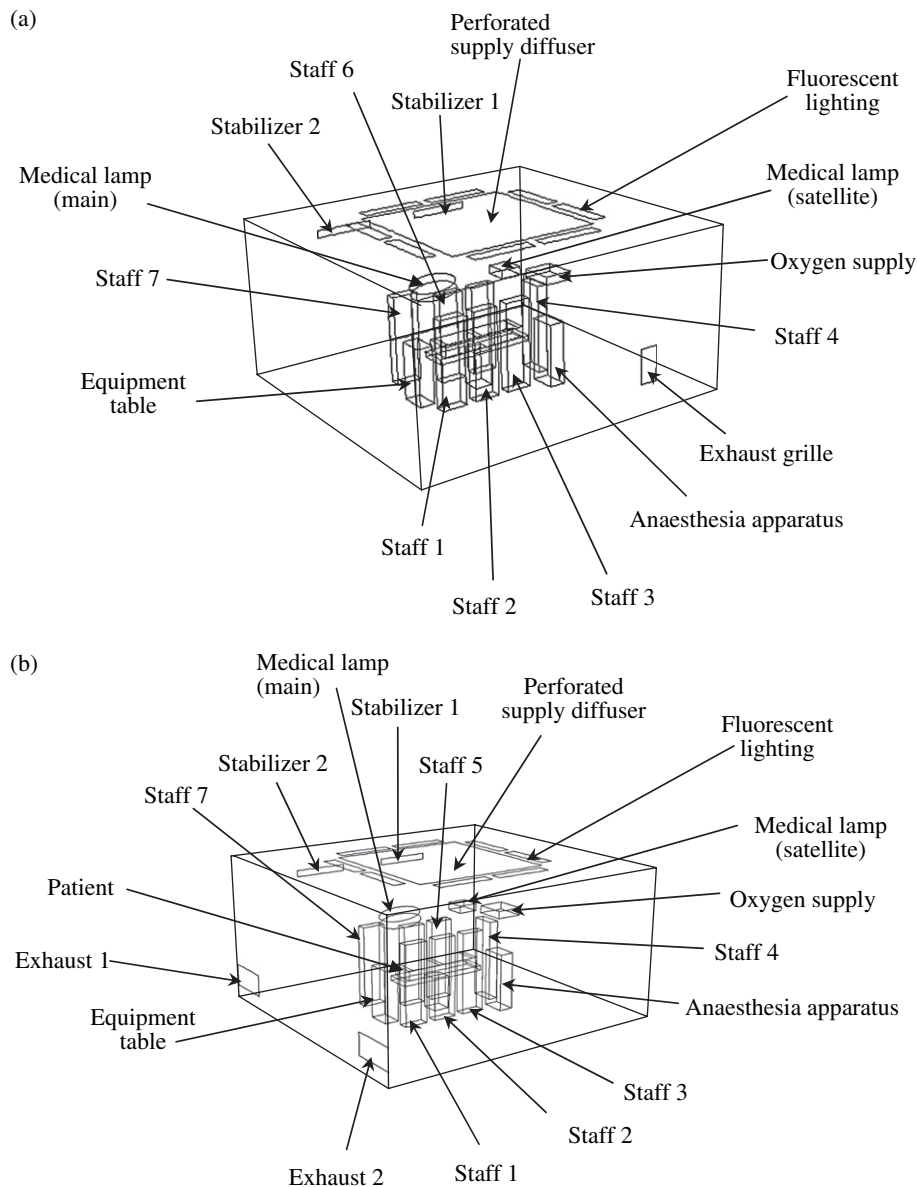

**Figure 2** Floor plan of operating theatre suite after pressure conversion. E.D., exhaust duct; OT-1, Operating Theatre 1; OT-2, Operating Theatre 2; AC, air conditioning.

conversion, are shown in [Figure 3](#) (a) and (b), respectively. The room dimensions were 6.3 m (length)  $\times$  5.9 m (width)  $\times$  3.1 m (height). In the computer model, the seven surgical staff standing upright and the patient lying on the operating table were represented as rectangular solid boxes. In the analysis, it was assumed that each staff member released infectious particles at a rate of 100 CFU/min from the body surface that faced the patient. Also, an assumption was made that an infectious particle release rate of 400 CFU/min occurred from the surgical incision site at the waist position and from the patient's upper surfaces. The main and satellite medical lamps were 350 W and 200 W, respectively, and produced heat fluxes from their downward surfaces. Each of the eight fluorescent lighting panels surrounding the perforated supply diffuser released a heat flux of 70 W. The flow of fresh air was 0.85 m<sup>3</sup>/s.

For Case A (positive pressure), the exhaust airflow at the exhaust grille was 0.21 m<sup>3</sup>/s and the balance airflow of 0.64 m<sup>3</sup>/s was a combination of discharge from the two pressure stabilizers and the gaps between the doors and the floor. For Case B (negative pressure), the total air extraction rate through the two exhaust grilles was 1 m<sup>3</sup>/s. The balance airflow of 0.15 m<sup>3</sup>/s entered the room through the two pressure stabilizers. A deflector plate was positioned 0.15 m in front of Stabilizer 2 to divert the incoming flow upwards. These constituted the only differences between the two cases, and hence the simulation results can be readily compared.

Numerical simulations were performed with the commercial CFD software FLUENT.<sup>11</sup> The standard empirical model was adopted to simulate the flow turbulence. Only steady-state conditions were considered.



**Figure 3** Computation models of Operating Theatre 1 before and after the pressure conversion. (a) Positive pressure, (b) negative pressure.

## Results

### Performance tests

After some months of construction, refitting, repeated performance checking and testing, most system requirements were met successfully with the exception of the differential pressure levels. Problems in the control of room air pressure mainly related to the quality of the building construction. It was not possible to make the room enclosure totally airtight. The other significant problem encountered was the backflow of contaminated air from the negative pressure theatre into the

anteroom, as observed by the smoke test when the sliding doors of the operating theatre were opened. Adding a deflector plate in front of Stabilizer 2 above the entrance door from the scrub room finally rectified this. Table 1 compares some room pressure measurements with the original design specifications. Although the differential pressures measured by repeated checking remained less than the design specifications, the actual working conditions were found to be acceptable. Colony counts of less than 30 CFU/m<sup>3</sup> for the TSA agar and less than 3 CFU/m<sup>3</sup> for the Sabouraud agar were achieved consistently in the routine checks.



**Table 1** Pressure (in Pascals) recorded in a routine check of the negative pressure theatre

Location	Intended pressure	Differential pressure (all doors closed)	Differential pressure (anteroom with one door opened)
Anteroom	+10	+6.1	0
Scrub room	-10	-1.9	-4.3
Induction room	-10	-6.2	-8.6
Operating Theatre 1	-15	-11.3	-14.3
Dirty corridor	+10	+3.0	-1.6

## Simulation results

The airflow pattern of Case B (negative pressure) was found to be generally consistent with the smoke dispersion pattern as visualized through the smoke tests during the commissioning period. The results showed that the airflow systems performed reasonably well both before and after conversion from positive pressure to negative pressure.

Figure 4 shows the simulation results of the differential patterns of room air temperature, i.e.

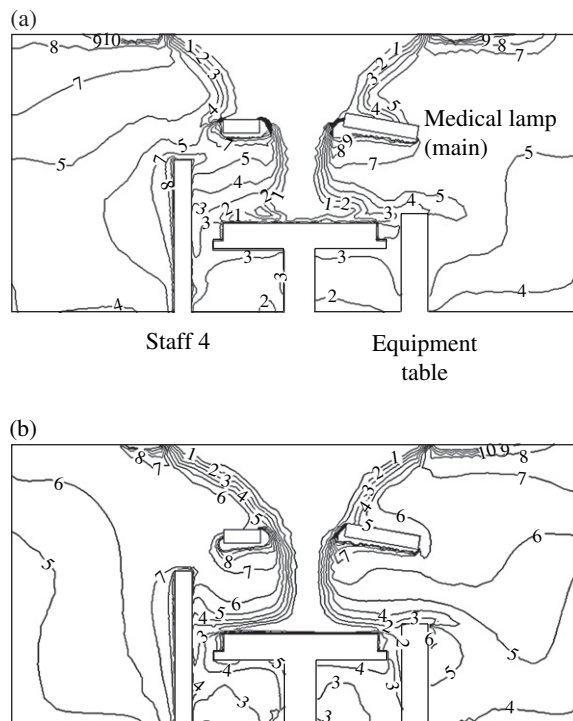

**Figure 4** Contours of temperature rise in degrees Celsius (above temperature of air supply) at mid-width cross-section of theatre. (a) Case A, positive pressure; (b) Case B, negative pressure.

the temperature rise above the supply air temperature at the diffuser outlet for Cases A and B.

Figure 5 shows the distribution of infectious particles released from the bodies of staff at the operating level, i.e. 1.1 m from floor level.

Figure 6 shows the concentration of bacteria released from the patient's wound site in the vertical plane, i.e. the situation across the incision site.

In the negative pressure theatre, a deflector plate was added to prevent backflow of the air from OT-1 to the anteroom. Figure 7 compares the velocity profiles before and after the addition of this deflector plate.

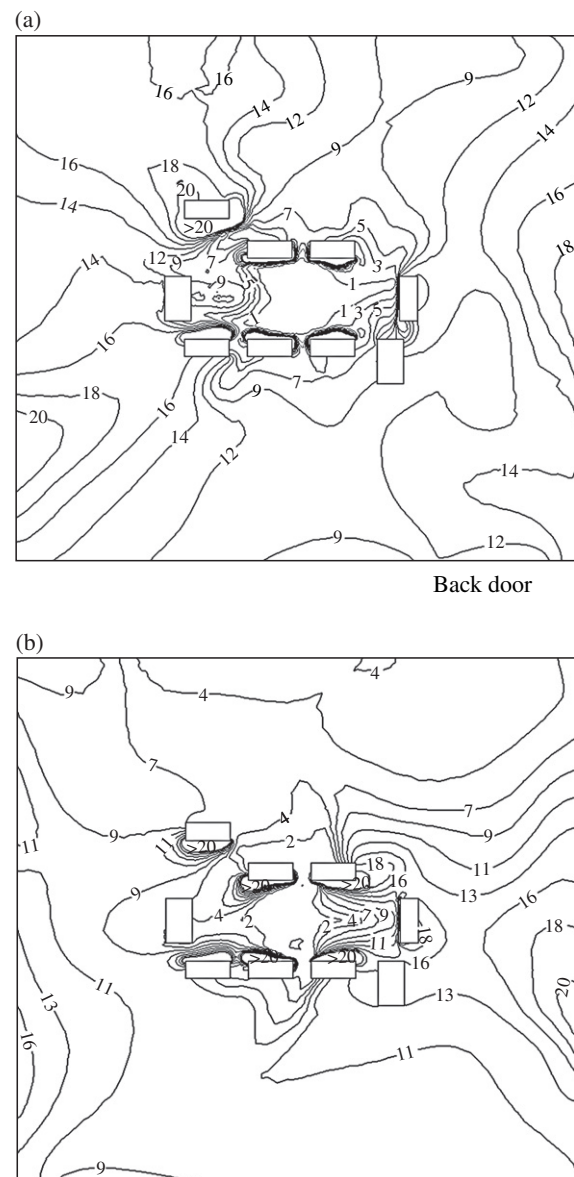

**Figure 5** Comparison of concentration distribution of bacteria (released from staff) at operating plane, 1.1 m from floor level (unit: colony-forming units/m<sup>3</sup>). (a) Case A, positive pressure; (b) Case B, negative pressure.

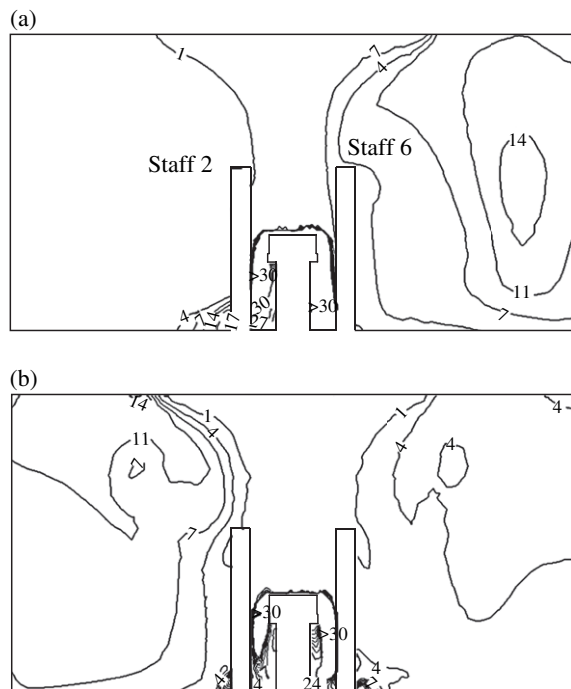
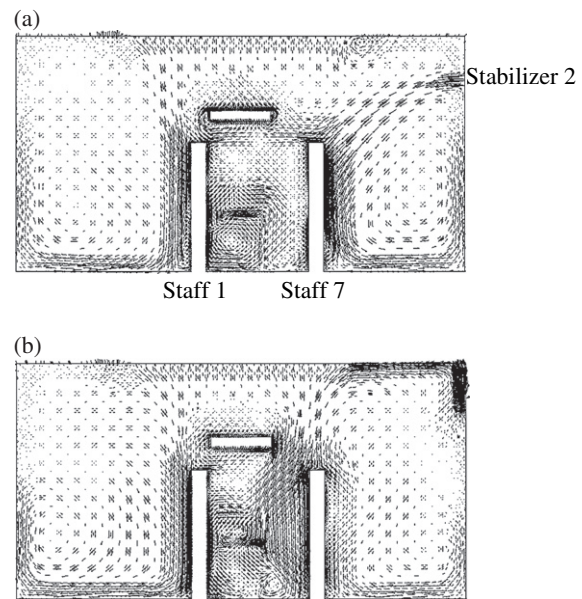

**Figure 6** Comparison of concentration distribution of bacteria (released from patient) at mid-length cross-section of the theatre, cutting across the wound position of the patient (unit: colony-forming units/m<sup>3</sup>). (a) Positive pressure, (b) negative pressure.

## Discussion

The room temperature conditions shown in [Figure 4](#) were compared on a vertical plane cutting across the operating table. Steep temperature gradients were found at the boundaries of the supply air streams from the diffuser outlet down to the level of the operating table. This was caused by the higher flow velocity between the two medical lamps, with the effect being more obvious in the negative pressure model. Hence, in the surgical zone, the patient is in a lower temperature environment (closer to the temperature of the supply air) than the general environment. This amounted to a difference of 4–5 °C, being more pronounced in the negative pressure model. The vertical temperature stratification was not obvious in most free positions of the room (around 2 °C difference from feet to head level for most room positions). Hence, thermal comfort was achieved in both models, consistent with the requirements of the International Standard Organization's standard on thermal comfort.<sup>12</sup>

It can be seen from [Figure 5](#) that the concentration levels were low (<10 CFU/m<sup>3</sup>) for all cases at the operating table (centre of the room). Hence, both models provide good protection for the patient as



**Figure 7** Comparison of velocity vector at one-third length of theatre, vertical plane cutting across the wall inlet cross with or without the deflection. (a) Negative pressure design without deflector plate, (b) negative pressure design after deflector plate added.

the bacterial concentration here is relatively low compared with the rest of the room. The vertical unidirectional airflows were effective in both cases.

The effectiveness of the air stream in removing the bacteria is obvious in [Figure 6](#). The infectious particles were shown to flow below the operating table until being drawn out of the room via the exhaust grille(s). At the level of the respiratory system, i.e. 1.6 m above floor level, the concentration of infectious particles released from the patient was less than 10 CFU/m<sup>3</sup>. This means that surgical staff are at little risk of being infected by the patient during the operation. At the same time, there was no evidence that adding the deflector plate affected the airflow streams. The flow pattern in [Figure 7\(b\)](#) shows a better flow in the surgical zone than in [Figure 7\(a\)](#). Hence, lower bacteria concentration levels in the same zone were achieved.

Overall, although the risk of cross-contamination from airborne infection is low if staff are adequately protected with appropriate PPE, a negative pressure operating theatre can offer optimal protection to personnel working in adjacent areas. Careful selection of the site is required to avoid contamination from other sites such as hospital wards. It has been shown that although the actual pressure differentials in the negative pressure rooms after completion may not meet the design specification, the actual working conditions can still be adequate if the designated airflow path



and flow rates can be maintained. In the present case, repeated testing and the results of periodical air sampling checks confirmed the quality of the completed work. Moreover, the steady-state simulation results showed that the level of thermal comfort as well as the dispersion behaviour of the bacteria in the negative pressure theatre were as good as, if not better than, those in the original positive pressure design.

## Acknowledgements

The work described in this article was supported by a strategic research grant from the City University of Hong Kong (project no. 7001609).

## References

1. Seto WH, Tsang D, Yung TY, *et al.* Effectiveness of precautions against droplets and contact in prevention of nosocomial transmission of severe acute respiratory syndrome (SARS). *Lancet* 2003;**361**:1519–1520.
2. Kwan A, Fok WG, Law KI, Lam SH. Tracheostomy in a patient with severe acute respiratory syndrome. *Br J Anaesth* 2004;**92**:280–282.
3. Essex-Lopresti M. Operating theatre design. *Lancet* 1999;**353**:1007–1010.
4. National Health Service Estates. *Health Technical Memorandum 2025. Ventilation in healthcare premises*. London: HMSO; 1994.
5. Friberg B, Friberg S, Burman LG. Inconsistent correction between aerobic bacterial surface and air counts in operating rooms with ultra clean laminar air flows: proposal of a new bacteriological standard for surface contamination. *J Hosp Infect* 1999;**42**:287–293.
6. Chen Q, Zheng J, Moser A. Control of airborne particle concentration and draught risk in an operating room. *Indoor Air* 1992;**2**:154–167.
7. Colquhoun J, Partridge L. Computational fluid dynamics applications in hospital ventilation design. *Indoor Built Environ* 2003;**12**:81–88.
8. Chow TT, Yang XY. Performance of ventilation system in a non-standard operating room. *Build Environ* 2003;**38**:1401–1411.
9. Chow TT, Yang XY. Ventilation performance in the operating theatre against airborne infection: numerical study on an ultra-clean system. *J Hosp Infect* 2005;**59**:138–147.
10. Woloszyn M, Virgone J, Melen S. Diagonal air-distribution system for operating rooms: experiment and modeling. *Build Environ* 2004;**39**:1171–1178.
11. Fluent Inc. *User's guide for Fluent 6.1*. Lebanon: Fluent Inc; 2003.
12. ISO Standard 7730. *Moderate thermal environment – determination of the PMV and PPD indices and specification of the conditions for thermal comfort*. Geneva: International Standard Organization; 1990.