



Since January 2020 Elsevier has created a COVID-19 resource centre with free information in English and Mandarin on the novel coronavirus COVID-19. The COVID-19 resource centre is hosted on Elsevier Connect, the company's public news and information website.

Elsevier hereby grants permission to make all its COVID-19-related research that is available on the COVID-19 resource centre - including this research content - immediately available in PubMed Central and other publicly funded repositories, such as the WHO COVID database with rights for unrestricted research re-use and analyses in any form or by any means with acknowledgement of the original source. These permissions are granted for free by Elsevier for as long as the COVID-19 resource centre remains active.



A pilot study on the disinfection efficacy of localized UV on the flushing-generated spread of pathogens

A.C.K. Lai^{a,*}, S.S. Nunayon^a, T.F. Tan^b, W.S. Li^{c,d}

^a Department of Architecture and Civil Engineering, City University of Hong Kong, Tat Chee Avenue, Kowloon, Hong Kong

^b Shenzhen Key Laboratory for the Sustainable Use of Marine Biodiversity, Research Centre for the Oceans and Human Health, City University of Hong Kong Shenzhen Research Institute, Shenzhen, China

^c Queen Mary Hospital, Pokfulam Road, Hong Kong

^d School of Public Health, The University of Hong Kong, Hong Kong



ARTICLE INFO

Keywords:

Airborne contaminants
Flushing-generated water droplets
Toilet air quality
Upper-room germicidal irradiation
Pathogen disinfection
Localized UV-C disinfection

ABSTRACT

The process of toilet-flushing can generate flushing-associated water droplets which can potentially expose humans to pathogen-laden aerosols. Very little is known about such aerosol dissemination or the means for minimizing exposure to these aerosols. This study has evaluated the efficacy of ultraviolet waveband C (UV-C) for disinfection of flushing-generated pathogen-laden aerosols through tests with localized disinfection systems for airborne and surface contaminations. Three types of bacteria were chosen for investigation: *Staphylococcus epidermidis*, *Escherichia coli*, and *Salmonella typhimurium*. Tests were conducted with UV-C tubes of 5 W and 10 W. High levels of disinfection efficacies were observed, ranging from 76% to 97% for bacteria-laden aerosols at sources of emission, and efficiencies of 53% to 79% for surface samples in localized systems. The results from the localized systems were further compared with those obtained with an upper-room ultraviolet germicidal irradiation (UVGI) system. As it is important to note, the UV-C doses and ozone emissions for the localized systems were found well below the limits recommended in current guidelines. This research has shown that the disinfection of flushing-generated pathogen-laden aerosols in proximity to the source of emission was more effective than at the more distant sites where aerosols may be dispersed to the environment.

1. Introduction

Toilets, also known as washrooms, cater to one of the most basic human physiological needs. On average, humans visit the toilets five to six times a day [1]. Toilets are hot-spots for micro-organisms and the environmental characteristics of toilets are favorable for the formation and growth of biofilms, because of the mesophilic nature of these micro-organisms. Toilet hygiene, particularly in public toilets and toilets in developing countries, is therefore, a significant public health concern.

Numerous bacteria and viral causative agents of gastrointestinal infection can be found in human feces. Human pathogens such as *Escherichia coli* (*E.coli*), *Enterococcus faecalis*, and *Serratia marcescens* (*S. marcescens*) have been found shed in feces. Previous studies have shown that extremely high bacteria concentrations per gram of stool (of about 10^5 to 10^9 for *Shigella* and 10^4 to 10^8 for *Salmonella*) are contained in the feces of some infected persons, and concentrations of 10^8 to 10^9 have been reported for norovirus [2]. In addition, gastrointestinal

pathogens, the severe acute respiratory syndrome coronavirus (SARS-CoV), deadly avian influenza viruses and the Ebola virus have been found in fecal materials [3–5].

A single toilet flushing generates between hundreds of thousands and millions of aerosols, due to the force of water running down the surfaces of the bowl, and the turbulence caused by water mixing in the bowl [6,7]. When pathogenic organisms are shed along with fecal materials into the toilet bowl, numerous pathogen-laden droplets of aerosol are produced [8–10].

A few studies have measured the concentrations of airborne organisms from toilets seeded with specific pathogens. One experiment involved seeding a residential toilet with *S. marcescens* to measure airborne concentrations after flushing [9], and found that the abundance of *S. marcescens* in the air increased sharply, from zero CFU/m³ (colony-forming units per cubic meter) to 1370 CFU/m³ after the first flushing. A similar study was recently conducted in a hospital to determine the concentration of *Clostridium difficile* following flushing [11]. The present authors investigated the emission strength of three

* Corresponding author.

E-mail address: alvinlai@cityu.edu.hk (A.C.K. Lai).

<https://doi.org/10.1016/j.jhazmat.2018.07.003>

Received 5 February 2018; Received in revised form 25 June 2018; Accepted 1 July 2018

Available online 03 July 2018

0304-3894/ © 2018 Elsevier B.V. All rights reserved.

pathogens following toilet flushing under flushometer and cistern tank scenarios [12]. Airborne emission was evidenced, and the emission for the first flush was found to be strongly correlated with bacteria sizes. This was an important finding, which demonstrated bacteria aerosolization, environmental contamination, and potential biological exposure from toilet flushing. With the extremely high load of viable pathogens found in feces, toilet flushing can be a potential source of infection [6,8].

It is widely understood that there are two routes of exposure or transmission of infectious airborne pathogens due to toilet flushing, namely primary (also called airborne) and secondary (surface or fomite) contaminations [9–11,13]. Primary pathway infection occurs by direct inhalation of pathogenic airborne droplets [14–16]. It is not unreasonable to suggest that enteric viruses in the air present a potential risk of infection via inhalation and swallowing [9].

Also, it is inevitable that a toilet user will touch various surfaces inside the cubicle. Secondary exposure is no doubt an additional risk, as toilet users may become infected whenever they touch surfaces already contaminated by rapidly falling fecal microbes. This source of contamination is also a major public health concern, as hand contact with contaminated surfaces can result in self-inoculation through touching the eyes, nose, or mouth [8]. Surface contamination studies have identified significant microbial contamination of washroom surfaces, including doors, toilet seats, sinks, and floors [9,13,17].

Apart from ventilation system design, virtually no engineering strategy has been developed and implemented on a wide scale to control the risk of infection from toilets. Various commercial products have been developed, such as toilet seat papers, toilet seat disinfectant gels/foams, and automatic toilet bowl cleaners or tablets [18]. These products may be effective for controlling the “existing” pathogens on the bowl surfaces or toilet seats. However, none of these measures can completely prevent transmission through the aerosolization of fecal matter during toilet flushing. Therefore, in-situ disinfection is needed to reduce the concentrations of airborne pathogens from toilets both in the air and on surfaces.

UV-C radiation is considered a cost-effective, high-efficiency means of disinfection. UV-C radiation has been proven to be an effective tool for decontaminating various surfaces [19]. The Centers for Disease Control and Prevention (CDC) has recommended that upper-room ultraviolet germicidal irradiation (UR-UVGI) should be used as a supplement for tuberculosis infection control in health-care settings [20]. Installations for UR-UVGI have been designed to inactivate airborne pathogens, and this approach has the advantages of low initial and running costs, low maintenance requirements, and ease of relocation.

We propose an alternative method of disinfection, using a localized, targeted approach. To test this approach, a UV lamp was located near the vicinity of the contaminated sources to inactivate the flushing-generated contaminants. According to the fundamental principle of pollution control, it is always best to control at the source, rather than seeking to control after dispersion. This concept has been widely applied in various industries such as local exhaust ventilation systems. For toilet disinfection using a localized UV-C installation, the mechanism should be characterized by small size, high efficiency, and minimal risk to users from exposure to irradiation. Our experiment is the first pilot study to test the use of this configuration for the inactivation of flushing-generated contaminants. The efficacy of disinfection is measured for both airborne and surface contaminations, and the results are compared with those for UR-UVGI.

2. Study design

A custom-built, self-contained toilet system was designed and fabricated [12]. The experiments were conducted in a chamber [2.25 m × 2.3 m × 2.3 m (L × W × H)] in which the environmental conditions were controlled precisely. As a mechanical ventilation system could serve as another “removal” mechanism that would have

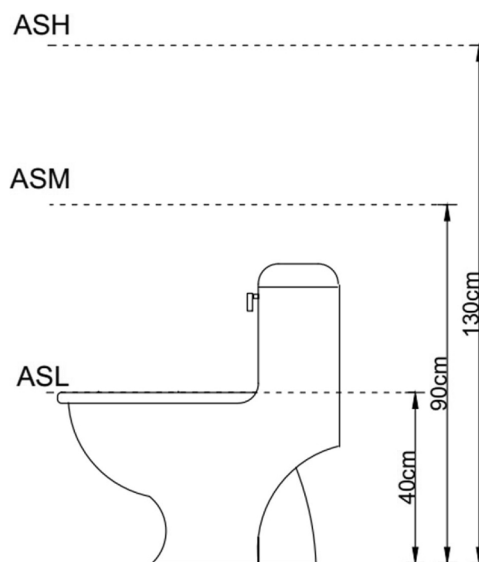

Fig. 1. Designated positions for air samples.

impacted the interpretation of the results, no mechanical ventilation was operated during our tests. This is because the concern of this study is to investigate the performance of only the UVC devices. The temperature and RH were held constant, and effectively maintained at 24 °C and 55%, respectively. The leakage of the chamber was determined to be less than 0.5 air change per hour (ACH).

Two types of UV-C disinfection systems were used: an upper room, and a localized system. An UR-UVGI fixture with a germicidal lamp (TB-12-W, American Ultraviolet) was mounted at the center of the side wall near the outlet, at a height of 2.05 m. This fixture held a 16 W UV-C lamp. Such a system has been used in other studies [21,22]. For the localized configuration, lamps with two power levels were used: 5 W and 10 W (Philips, PL-S, TUV), each of them with a ballast housed in a water-resistant clear Perspex box.

Single-stage bioaerosol impactors (Thermo Scientific) were installed to collect airborne samples at heights of 130 cm, 90 cm, and 40 cm for the high (ASH), middle (ASM), and low (ASL) level air sample collections, respectively (Fig. 1). The pumps flow rates were calibrated at 28.3 liters per minute (LPM).

3. Methodology

3.1. Preliminary investigation (surface contaminants)

Preliminary experiments were undertaken to determine how far the droplets could travel from the toilet. Up to thirteen 90 mm nutrient agar plates were placed around the toilet seat (Fig. 2) around the bowl surface. The toilet was seeded with *E. coli*, and no UV-C device was used. The results showed that the bacteria were settled mainly at the rim of the toilet, that is, at S1, S2, S3, and S4. Colony-forming unit (CFU) counts for the other locations were less than 10. Thus, for our surface disinfection experiments, only those agar plates positioned at S1, S2, S3, and S4 were studied by the settle plate method.

3.2. Selection of micro-organisms

The selection criteria for the micro-organisms were based on biosafety issues and pathogenic properties. Three species of bacteria having biosafety level one were selected as surrogates of pathogenic species commonly found in toilet microenvironments. The first species was *Staphylococcus epidermidis* (*S. epidermidis*) (ATCC 12228), which was gram-positive cocci with spherical shape with a diameter of around 0.96 μm and arranged in clusters. The other two species were *E. coli*

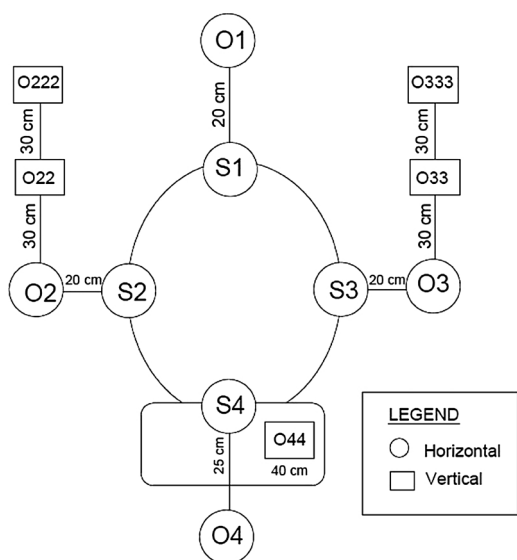

Fig. 2. Preliminary surface sampling locations.

Table 1

Volume of bacteria considered for each experiment.

S/N	Bacteria Name	Notation	Volume
1	<i>Staphylococcusepidermidis</i>	ATCC #12228	20 ml
2	<i>Escherichia coli</i>	ATCC #10536	250 ml
3	<i>Salmonella typhimurium</i>	ATCC #53648	250 ml

(ATCC 10536) and *Salmonella typhimurium* (*S. typhimurium*) (ATCC 53648), both are gram-negative bacilli in a rod shape. The diameter of *E. coli* is about 1.0 μm and about 2.0 μm long [23]. Similarly, the diameter of *Salmonella typhimurium* is around 1.5 μm, with a length of 2–5 μm [24]. Bacteria suspension was transferred into the toilet bowl for each experiment (Table 1). The volume of *S. epidermidis* (20 ml) used in our experiment was lesser than *E. coli* and *S. typhimurium* (250 ml each) because it has the least size, thus, using more volume would generate too many bacteria counts, which made it very difficult to estimate the exact CFU.

3.3. Configurations of the UV-C systems

Two types of UV-C systems were tested: upper-room and localized devices. For the localized system, two UV-C lamps with power levels of 5 W and 10 W were tested, each with a ballast housed in a water-resistant box made of clear cast acrylic sheet. Thus, altogether there were three configurations (Configurations 1, 2, and 3), the details of which can be found in Table 2. An UR-UVGI fixture was mounted at the center of the side wall near the outlet, such that the lower part is at a height of 2.05 m above the floor level, which is approximately the height (2.10 m) reported in Xu et al. [25] and slightly above the height (1.96 m) considered in Yang et al. [22].

The localized device was installed below the rim of the toilet bowl

Table 2

Different configurations of UV-C systems.

Configuration	UV-C System	UV-C Power & Dimensions
1	Localized UV-C	5 W rating, 62 mm long, housed in a Perspex box (104 mm × 94 mm × 53 mm).
2	Localized UV-C	10 W rating, 127 mm long, housed in a Perspex box (150 mm × 72 mm × 57 mm).
3	UR-UVGI	12 W, 30 cm long housed in a fixture 470 mm (L) × 250 mm (D) × 130 mm (H).

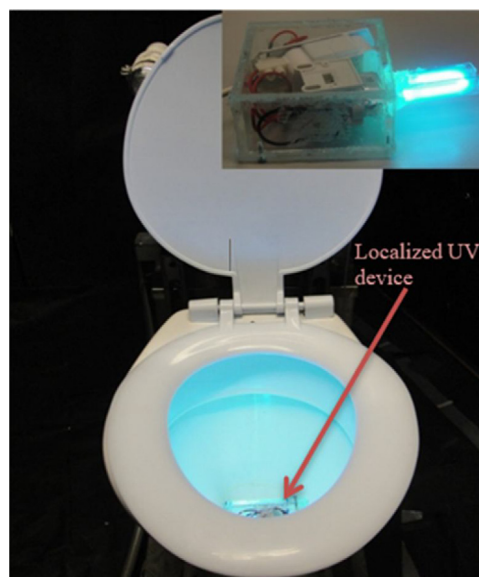

Fig. 3. The localized UV-C set-up. The insert shows the localized system with 5 W UVC tube. The localized device is hung near the rim of the toilet.

(Fig. 3). Then three conditions of experimental measurements were performed. For the first condition, the three types of bacteria were used to test the disinfection performance of the 5 W localized UV-C lamp. For the second condition, the 10 W localized UV-C system was used. For the final condition, only *E. coli* was selected for testing the disinfection efficacy of UR-UVGI. For all the three conditions, both air and surface samples were taken for analysis.

3.4. Experimental procedure

Prior to soiling the toilets with bacteria, the toilet bowl and the cistern were thoroughly cleaned with 100 ml of commercially available Clorox (chlorine) bleach, and then flushed three times, to eliminate traces of the cleaning compound and any micro-organisms present in flushing water. A solution of 12 ml of sodium thiosulphate was then added to inactivate any bleach chemicals present in the water. Finally, water was again used to wash the bowl and cistern in the same manner as previously described. The source of water during the experiment was tap water supplied by the Water Supplies Department of Hong Kong. This cleaning process was repeated before each experiment. After thoroughly cleaning the system, the tank was filled with water. The localized UV-C device was installed and switched on to allow for a 6-minute warm-up period. During the warm-up period, no bacteria were inoculated into the toilet to avoid killing the bacteria before flushing. The air sampling apparatuses were mounted in predetermined positions for sample collection.

When the bacteria were poured into the toilet bowl, lids of the agar plates for surface sample collection were opened, and the door of the test chamber was completely closed.

Air samples were collected above the center of the toilet bowl in three designated heights, labeled ASL, ASM, and ASH for low-level air samples, middle-level air samples, and high-level air samples, respectively. Thus, to sample the three positions, sampling tubes were used. Each impactor was connected to a cast acrylic sheet squared box (151 mm × 151 mm × 151 mm) at one end, and a copper tube of 12 mm diameter and 1 m in length was connected to another end of the box. The air samples were transferred to the agar plates through the copper tubes and the cast acrylic sheet square box. The schematic of the copper tube-acrylic box sampling manifold is shown in Fig. 4. The essence of the box is to contain air samples being sucked through the copper tube and aid the collection of same by the agar plate. Similarly,



Fig. 4. A schematic of the copper tube-acrylic box sampling manifold.

four agar plates with lids (covers) were located at points S1, S2, S3, and S4 on the toilet seat for surface sampling [see Supportive Information].

For safety reasons, no one was allowed inside the chamber during the experiments. To activate the flushing, a long string was attached to the flush lever, to allow the toilet to be flushed from outside the test room. The toilet was flushed to generate airborne micro-organism emission, and the vacuum pump was simultaneously turned on for air sample collection. Air and surface samples were collected for 1 min and 3 min by settling plate methods on nutrient agars since droplets require more time than the droplet nuclei to settle on surfaces. All seven samples (3 air and four surface samples) were collected on a series of nutrient agar plates, which were then incubated at 37 °C for 24 h. The same procedure was implemented for the UR-UVGI. A control measurement (UV-C OFF) was also performed. All the experiments were performed at least in triplicate.

3.5. Measurement of UV-C intensity, dose, and ozone emission

All types of mercury lamp require warm-up time to deliver full irradiance. Thus, it was important to determine the warm-up time and the corresponding intensities ($\mu\text{W}/\text{cm}^2$) for the 5 W and 10 W tubes, to compare if correlations existed between the intensity and the disinfection efficacy. Nonetheless, it was not necessary to measure the absolute intensity. In this study, we measured the intensity of the UV-C lamps by using a radiometer (IL1400 A, International Light Technologies) equipped with a suitable detector, with a sensitivity peak at 254 nm wavelength. This sensor was placed 30 cm horizontally distant from the radiometer. Upon switching on the UV-C lamp, the intensity was recorded at every one-minute interval for a period of 11 min.

The UV-C dose received by toilet users is an important health concern. During the process of a toilet flushing, the relative orientation and distance between the user's eye level and the toilet bowl vary with the user's posture. In this study, the UV-C dosage was also measured by using the same radiometer, which had a built-in function for integrating the intensities at any period and giving the resulting doses in mJ/cm^2 . A light sensor was held at eye level by the left hand of a volunteer wearing UV-C protective glasses, while the volunteer's right hand pressed the flushing handle [see Supplementary Information]. This important parameter facilitated direct comparison, with reference to the guidelines of the American Conference of Governmental Industrial Hygienists (ACGIH) [26]. Likewise, the UV-C intensities of the UR-UVGI installation (at heights of 2.05 m) were measured. Moreover, as ozone is a by-product of UV-C emission and a harmful pollutant, emission of this gas in a confined environment such as a toilet becomes a critical health concern [27]. We, therefore, measured ozone concentrations with an ozone monitor (Model 205, 2B Technologies).

3.6. Preparation of tested bacteria

The three types of selected bacteria were separately inoculated onto the nutrient agar (NA, BD) plates from frozen stocks. A colony of each type of bacteria was inoculated into the desired volume of nutrient broth (BD), and incubated in an orbital shaker at 37 °C for 24 h to reach a stationary phase. The input for each type of bacteria suspension was 10^9 to 10^{10} cells.

4. Data analysis

4.1. Disinfection efficacy

We calculated the average disinfection efficacy of the total bacteria concentrations measured at three height levels (ASL, ASM, and ASH) for the air samples, and at four points (S1, S2, S3, and S4) for the surface samples, by applying Eqs. (1) and (2), respectively.

The averaged airborne sample disinfection efficacy of the UV-C system for the three heights, ($\bar{\eta}_{air}$) was defined as:

$$\bar{\eta}_{air} = \left(1 - \frac{\sum_{i=1}^3 CFU_{on,i}}{\sum_{i=1}^3 CFU_{off,i}} \right) \times 100\% \quad (1)$$

where i represents three different sampling heights, and CFU_{on} and CFU_{off} are the airborne CFU counts under the UV-C on and off conditions, respectively.

The averaged surface sample disinfection efficacy ($\bar{\eta}_{sur}$) of the UV-C system for the four points was determined by

$$\bar{\eta}_{sur} = \left(1 - \frac{\sum_{i=1}^4 SCFU_{on,i}}{\sum_{i=1}^4 SCFU_{off,i}} \right) \times 100\% \quad (2)$$

where i represents the four different sampling points; and $SCFU_{on}$ and $SCFU_{off}$ are the surface CFU counts under the UV-C on and off conditions, respectively.

5. Results

5.1. UV intensity

The irradiance of the UV-C lamps is depicted in Fig. 5 which shows that the irradiance approached steady output after 5 min. Also, our measurements showed that the intensity of the 10 W lamp was approximately twice as high as the 5 W lamp. Thus, we were interested in determining whether there was any direct correlation between lamp power levels and rates of disinfection.

5.2. Ozone emissions

The background ozone concentration in the experimental chamber without the devices operating was found to be 1.5 ppb. However, the

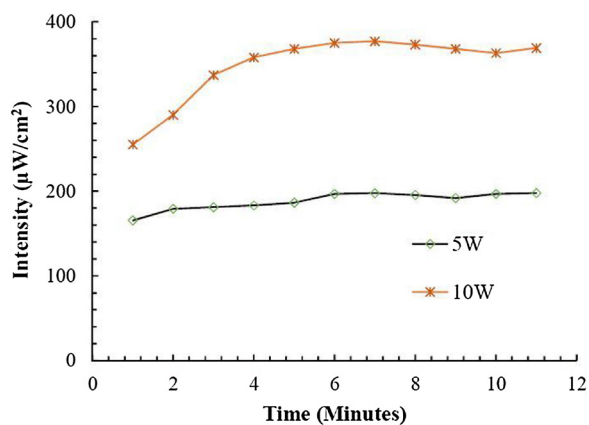

Fig. 5. The intensity of the UVGI lamps against time.

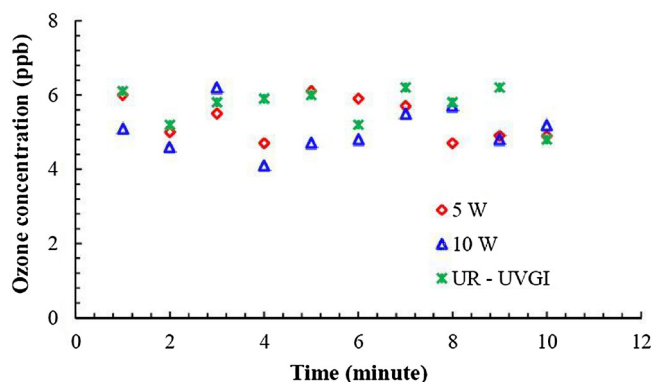

Fig. 6. Levels of UVGI ozone emission.

maximum ozone concentrations generated by our devices were 4.7 ppb–6.1 ppb, and 4.1 ppb–6.2 ppb for the 5 W and 10 W localized UV-C lamps, respectively. For the UR-UVGI, the ozone concentrations were between 4.8 ppb and 6.2 ppb. (Fig. 6). These levels of ozone emission were below the permissible exposure limit of 100 µg/m³ (50 ppb), as set by the World Health Organization [22].

The ozone emission rates of the localized UV-C lamps were found to be 4.63 mg/hr and 3.37 mg/hr for the 5 W and 10 W, respectively. The UVGI lamp had emission rate of 4.78 mg/hr. Some recent measurements showed that for 6 different air cleaners, the ozone emission rates of air cleaners ranged from 4.88 to 24.5 mg/h [28]. Table 3 illustrates that the emission rates of localized UV-C lamps used in this study compare favorably with other electronic devices.

5.3. UV dose measurement

For the localized UV-C installation, when the flushing was done at time = 5 min, the average doses of exposure at heights 140 cm and 70 cm were 0.03 mJ/cm² and 0.04 mJ/cm², respectively. For UR-UVGI,

Table 3

Comparison of ozone emission rates of UV-C lamps and other indoor electronic devices.

S/N	Devices	Average emission rates (mg/hr)	References
1	5 W localized UV-C	4.63	Current study
2	10 W localized UV-C	3.37	Current study
3	UVGI lamp	4.78	Current study
4	Laser jet printers		
	- Monochrome printing	0.032–5.82	[29]
	- Colour printing	0.726–10.5	[29]
5	Portable air cleaners	3.30–4.30	[30]

the intensity was below the detection limit of the radiometer [21]. The radiometer we used was calibrated to measure ultraviolet C (UV-C) at 254 nm wavelength. It was equipped with a model SEL240 detector having a dynamic range of 1.49 × 10⁻⁷ to 1.49 × 10⁻³ effective W/cm². According to the guidelines of the ACGIH [26] the exposure limit is 6 mJ/cm² per day.

5.4. Disinfection of airborne and surface pathogens by localized UV systems

The disinfection efficacy of airborne and surface samples under 5 W and 10 W localized UV systems for the three selected bacteria were shown in Fig. 7. The localized UV-C systems were shown to reduce the selected bacteria concentrations significantly following toilet flushes. Under both the 5 W and 10 W UV lamp exposure treatments, airborne disinfection of *E. coli* achieved 97.75 ± 1.62% and 97.32 ± 1.96%. Comparable rates of disinfection had been shown for *S. epidermidis*, about 76.31 ± 1.92% and 92.13 ± 3.80%, and *S. typhimurium*, about 82.60 ± 7.74% and 93.23 ± 2.12% for the 5 W and 10 W treatments, respectively.

It was interesting to compare the disinfection efficacy for the 5 W and 10 W UV-C lamps, as the UV radiation level of the 10 W lamp was almost twice that of the 5 W lamp. The statistical significance was calculated using the Student t-test. It was calculated using 3 replicates each for the low, medium and high sampling levels. The results with *S. epidermidis* showed significant differences of disinfection efficacy ($p < 0.05$) between 5W and 10W UV lamp exposures, but *E. coli* and *S. typhimurium* showed no significant differences.

For surface disinfection, the highest disinfection efficacy, of approximately 84.91 ± 3.6%, was attained with *S. epidermidis*, with no significant difference between 5 W and 10 W lamps. A significant difference in disinfection efficacy was observed between 5 W and 10 W UV lamps for *S. typhimurium* with the efficacy of 53.31 ± 9.39% and 78.40 ± 10.98% ($p < 0.05$). For *E. coli*, no significant difference was found, both 5 W and 10 W lamps provided 61.10 ± 5.6% and 68.31 ± 12.28 disinfection efficacies, respectively.

When airborne bacteria are exposed to the UV-C irradiation, the survival fraction of airborne bacteria is an exponential function of the irradiation intensity, the exposure time and the susceptibility of airborne bacteria, Z value [31]. The Z-value is the value that indicates the degree of sensitivity of microorganisms to the bactericidal effects of UV-C. The higher the z-value, the more susceptible is the microorganism to killing by the UV-C irradiation [32]. It is very difficult to obtain published Z-values for all the three bacteria tested in this study. The only obtainable previously published Z values of these bacteria showed that *E. coli* ($Z = 0.10575 \text{ m}^2/\text{J}$ and $Z = 0.50628 \text{ m}^2/\text{J}$ for surface and airborne disinfections, respectively) are more susceptible to UV-C than *S. Epidermidis* ($0.12670 \text{ m}^2/\text{J}$ for airborne disinfection) [32]. Additionally, the Z values also revealed that the susceptibility of *E. coli* to UV-C is also higher in airborne disinfection than surface disinfection. This explains the reason why our results showed that localized UV lamps achieved a much higher disinfection efficacy for *E. coli* (97.75 ± 1.62%) and *S. epidermidis* (76.31 ± 1.92%) in airborne disinfection while the opposite trend was observed from the surface samples (i.e. more *S. epidermidis* (84.91 ± 3.6%) is being removed, but for *E. coli*, only about 61.10 ± 5.6% removal for 5 W lamp system). To conclude, localized devices had a very high disinfection efficacy for both airborne microorganisms and surface contaminants.

5.5. Comparison of a localized UV system and UR-UVGI

The differing efficacies of surface and airborne disinfection between the localized UV system and the UR-UVGI were further evaluated by tests using *E. coli* (Fig. 8). The disinfection efficacy of UV lamps and UVGI were significantly different in both the airborne ($p < 0.01$) and surface ($p < 0.01$) experiments. As the UR-UVGI irradiation level measured at the toilet seat level was virtually zero, it was not surprising

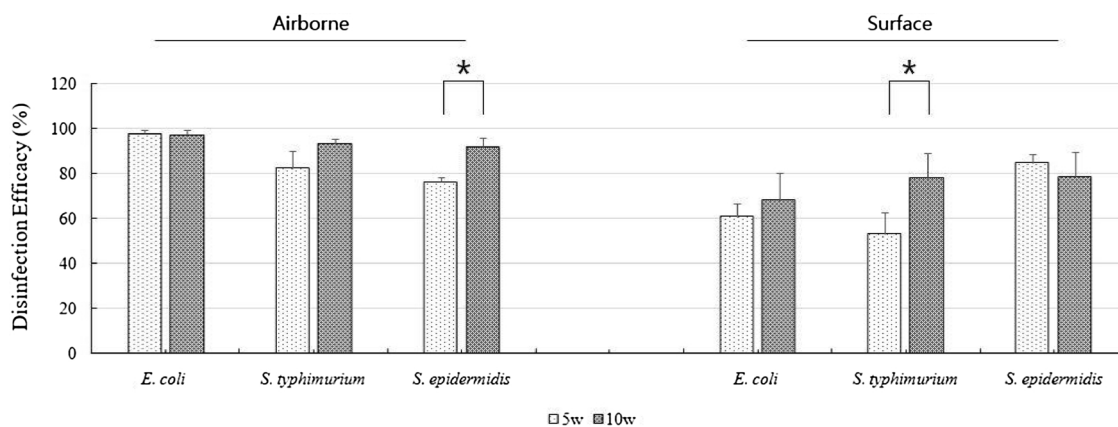

Fig. 7. Disinfection efficacy of localized UV lamps for airborne and surface contaminations. * means $p < 0.05$.

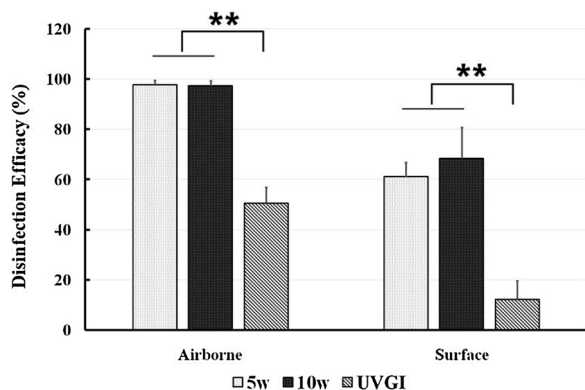

Fig. 8. Comparison of disinfection efficacy between localized UV lamps and UR-UVGI for *E. coli*. ** means $p < 0.01$.

to observe that the disinfection efficacy was very low. For the airborne bacteria test, the efficacy was $50.58 \pm 6.22\%$, and the localized devices showed $97.75 \pm 1.62\%$ and $97.32 \pm 1.96\%$ efficacies for both 5 W and 10 W lamps, respectively. The up-rising plume generated by flushing brought the micro-organisms to a higher level, up to where the UR-UVGI irradiation was strong.

6. Discussion

We genuinely anticipated that the UR-UVGI would give very good disinfection results. In fact, very high effectiveness of UR-UVGI has been reported in previous applications, such as TB isolation rooms or homeless shelters [33,34]. Three inter-related issues; emission characteristic, air mixing, and dose, attributed to the results. The emission characteristics of previous applications are very different from the toilet flushing conditions examined in this study. Most previous work on applying UVGI is for the well-mixed environment [25,35,36]. It should also be noted, however, that toilet emission is episodic with “initial” and “strong” emission stages of a toilet flushing. It has been found that improper air mixing can decrease the efficiency of UR-UVGI by around 80% [37]. Finally the difference in performance can also be attributed to the UV-C doses received by the micro-organisms. If the ACH is 8 h^{-1} , the residence time of micro-organisms is 450 s, but for an episodic event such as flushing a toilet, the UV-C dose received by the micro-organisms is substantially shorter than 450 s. As the ventilation exhaust grill is located right above the toilet bowl, it is anticipated that the residence time would be approximately 10 s. The current and existing studies are indicators that synergistic effect of UR-UVGI, localized UV lamps and ventilation would produce higher disinfection efficiency than individual disinfection mechanism.

To determine the UV-C exposure to users, we estimated the UV-C

dose for a single flushing process. For an individual who visits toilets eight times in an 8-hour period and is exposed to the localized UV-C installation, the UV doses received when the eye level is at heights 140 cm and 70 cm from ground level would be 0.24 mJ/cm^2 and 0.32 mJ/cm^2 , respectively. The average dose would only be 4.6% of the guideline-recommended dose limit (6 mJ/cm^2). Thus, the doses from the localized UV-C source did not appear to pose any health threat to the users’ eyes or skin under normal circumstances. However, for persons such as janitors, who may need to repeatedly bend down to clean toilet bowls, the UV-C dose exposure is expected to be higher. To avoid over-exposure, the UV-C sources can be turned off during the cleaning period. Similarly, the ozone emissions from both localized UV-C sources were three to eight times less than the acceptable limit. The concerns over adverse health implications from exposure to localized UV-C have been addressed.

The extremely meager performance of the UR-UVGI at the surface could have been due to the low UV-C intensities observed, which were close to zero at the level of the toilet bowl, irrespective of the types of bacteria being tested. However, lowering the height of installation for the UR-UVGI was not feasible, as the dose of the UV-C would be excessive. Nonetheless, 50% disinfection was found for airborne samples. This result was attributed to the upward motion generated by flushing in the absence of mechanical ventilation. Previous studies have found that bacteria-laden aerosols were detected at heights of 20 cm and 25 cm upon flushing [8,9]. If mechanical ventilation is operated, higher rates of disinfection can be expected.

Flushing-induced aerosols are mainly super micron in size, so gravitational settling remains the main mechanism of deposition of airborne bacteria to bathroom surfaces. According to previous work by the author [12], we can assume flushing-generated droplet sizes to be approximately within $1 \mu\text{m}$ and $10 \mu\text{m}$. For a standard density spherical droplet, the settling velocities are $3.5 \times 10^{-5} \text{ m/s}$ and $3.05 \times 10^{-3} \text{ m/s}$ for $1 \mu\text{m}$ and $10 \mu\text{m}$, respectively. Assume the settling distance is 10 cm to contaminate a surface, it would take 2800s to 32 s. In practice, for mechanically ventilated toilets, the air exchange rate can be as high as 18 h^{-1} which leads the residence time to be approximately 200 s. If toilets have no mechanical ventilation, the residence time can be very long, say 30 min. To sum up, it implies that particle sizes at the upper end of the emission range could contaminate surfaces more readily than those smaller particles. However, the thermal plume generated by the toilet user as a result of the convective heat loss from the body, would enhance the air distribution in the toilet stall and further complicate the airflow.

Airflow will also affect exposure time. At the perspective of the current study, if the mechanical ventilation is so high to affect upward airflow, the dose received by the flushed-generated pathogens would be reduced and the pathogens would spread through the toilet without being disinfected. Surface contamination may also be affected.

The mechanism of UV-C pathogen inactivation is DNA damage, which results from electron movements. The pyrimidines and purine nucleic acid bases, which are the basic building blocks of DNA, absorb the photons directly from the photoproducts caused by UV-C irradiation [38–40]. Studies on photoreactivation of various microorganisms have also established that bacteria had developed DNA repair mechanism in an attempt to restore the structure and function of DNA [41,42]. Once the maximal capacity for DNA repair is reached, additional UV-C exposure is able to kill the micro-organisms, causing an exponential drop in bacteria counts, as depicted by an exponential order of death seen in the survival curves of micro-organisms subjected to UV-C. This pattern might also explain our findings that there were no significant differences in disinfection efficacy between 5 W and 10 W lamps in most of the cases. This finding might also show that a UV-C lamp of less than 5 W is already capable of surpassing the micro-organisms' maximal DNA repair capability, and that additional benefits of stepping up the UV-C to a 10 W rating would be insignificant. Previous studies have also observed that increasing the fluence rate above an effective value did not lead to further improvements in disinfection [31].

It has been shown that UV sensitivity differs among different groups of micro-organisms, and that gram-negative bacteria are generally more sensitive than gram-positive bacteria, yeast, bacteria spores, molds, or viruses [40,41]. Similarly, our study showed that localized UV-C lamps were more effective for eliminating *E. coli* from airborne bioaerosols than for eliminating *S. Epidermidis* or *S. typhimurium*. *Salmonella* species were found more resistant to UV-C than *E. coli* [40].

It should also be noted that the lamp power of UR-UVGI was twice that of the localized devices. Nevertheless, the localized devices proved to be more effective. This outcome also confirmed that source control was more efficient than increasing the power rating. The widespread use of localized UVGI systems would minimize exposure to the pathogens spread to the air during toilet-flushing. Not only would such systems improve the air quality of washrooms, but also no secondary harmful products would be generated as in spray disinfection products. Another feature is the compact size. With the advance of electronic technology, the ballast and the UV-C tube can be made further smaller. Further investigations are recommended to test the effectiveness of such disinfection systems on other types of bacteria, and further improvements may result from more systematic designs and tests of UV-C source systems.

7. Conclusions

This study has evaluated the efficacy of UR-UVGI and localized UV-C devices for the disinfection of flushing-generated pathogens. The physical sizes of localized UV-C devices are smaller, and their levels of electrical power consumption used for disinfection are lower than those of UR-UVGI systems. Comparisons between these two forms of engineering controls showed significant differences in performance. The localized UV-C systems performed two times better than the UR-UVGI for disinfecting airborne samples, and five times better for disinfecting surface samples. The results of this study suggest that maximal disinfection of air in the washroom micro-environment was attained at source control before dispersal than the use of upper-room irradiation for dispersed emitted bacteria throughout the washroom. Inferring from the observed results, we conclude that the use of localized UV-C lamps is a feasible alternative approach for minimizing human exposure to pathogen emissions from toilet plumes.

Acknowledgment

The research described in this study was fully supported by a General Research Fund from the Research Grants Council of Hong Kong Special Administrative Region of China [CityU 115213; CityU 11204217].

Appendix A. Supplementary data

Supplementary material related to this article can be found, in the online version, at doi:<https://doi.org/10.1016/j.jhazmat.2018.07.003>.

References

- [1] J.M. Latini, E. Mueller, M.M. Lux, M.P. Fitzgerald, K.J. Kreder, Voiding frequency in a sample of asymptomatic American men, *J. Urol.* 172 (2004) 980–984.
- [2] R.L. Atmar, A.R. Opekun, M.A. Gilger, M.K. Estes, S.E. Crawford, F.H. Neill, Norwalk virus shedding after experimental human infection, *Emerg. Infect. Dis.* 14 (2008) 1553–1557.
- [3] T. Wolf, G. Kann, S. Becker, C. Stephan, H.R. Brodt, P. de Leuw, T. Grünwald, T. Vogl, V.A. Kempf, O.T. Keppler, Severe Ebola virus disease with vascular leakage and multiorgan failure: treatment of a patient in intensive care, *Lancet* 385 (2015) 1428–1435.
- [4] J.S. Peiris, K.Y. Yuen, A.D. Osterhaus, K. Stohr, The severe acute respiratory syndrome, *N. Engl. J. Med.* 349 (2003) 2431–2441.
- [5] M.D. de Jong, V.C. Bach, T.Q. Phantom, M.H. Vo, T.T. Tran, B.H. Nguyen, M. Beld, T.P. Le, H.K. Truong, V.V. Nguyen, T.H. Tran, Q.H. Do, J. Farrar, Fatal avian influenza A (H5N1) in a child presenting with diarrhea followed by coma, *N. Engl. J. Med.* 352 (2005) 686–691.
- [6] D. Johnson, R. Lynch, C. Marshall, K. Mead, D. Hirst, Aerosol generation by modern flush toilets, *Aerosol Sci. Technol.* 47 (2013) 1047–1057.
- [7] K. Lin, L.C. Marr, Aerosolization of Ebola virus surrogates in wastewater systems, *Environ. Sci. Technol.* 51 (2017) 2669–2675.
- [8] C.P. Gerba, C. Wallis, J.L. Melnick, Microbiological hazards of household toilets: droplet production and the fate of residual organisms, *Appl. Microbiol.* 30 (1975) 229–237.
- [9] J. Barker, M. Jones, The potential spread of infection caused by aerosol contamination of surfaces after flushing a domestic toilet, *J. Appl. Microbiol.* 99 (2005) 339–347.
- [10] M. Verani, R. Bigazzi, A. Carducci, Viral contamination of aerosol and surfaces through toilet use in health care and other settings, *Am. J. Infect. Control* 42 (2014) 758–762.
- [11] E.L. Best, J.A.T. Sandoe, M.H. Wilcox, Potential for aerosolization of *Clostridium difficile* after flushing toilets: the role of toilet lids in reducing environmental contamination risk, *J. Hosp. Infect.* 80 (2012) 1–5.
- [12] A.C.K. Lai, T.F. Tan, W.S. Li, D.K.M. Ip, Emission strength of airborne pathogens during toilet flushing, *Indoor Air* 28 (2018) 73–79.
- [13] J.A. Otter, C. Donskey, S. Yezli, S. Douthwaite, S.D. Goldenberg, D.J. Weber, Transmission of SARS and MERS coronaviruses and influenza virus in healthcare settings: the possible role of dry surface contamination, *J. Hosp. Infect.* 92 (2016) 235–250.
- [14] Li Y. Yu ITS, T.W. Wong, W. Tam, A.T. Chan, J.H.W. Lee, D.Y.C. Leung, T. Ho, Evidence of airborne transmission of the severe acute respiratory syndrome virus, *N. Engl. J. Med.* 350 (2004) 1731–1739.
- [15] M. Nicas, W.F. Nazaroff, A. Hubbard, Toward understanding the risk of secondary airborne infection: emission of respirable pathogens, *J. Occup. Environ. Hyg.* 2 (2005) 143–154.
- [16] T.P. Weber, N.I. Stilianakis, Inactivation of influenza A viruses in the environment and modes of transmission: a critical review, *J. Infect.* 57 (2008) 361–373.
- [17] J. Barker, S.F. Bloomfield, Survival of *Salmonella* in bathrooms and toilets in domestic homes following salmonellosis, *J. Appl. Microbiol.* 89 (2000) 137–144.
- [18] M.T. Yahya, J.M. Cassells, T.M. Straub, Reduction of microbial aerosols by automatic toilet bowl cleaner, *J. Environ. Health* 55 (1992) 32–34.
- [19] M.M. Nerandzic, J.L. Cadnum, M.J. Pultz, C.J. Donskey, Evaluation of an automated ultraviolet radiation device for decontamination of *Clostridium difficile* and other healthcare-associated pathogens in hospital rooms, *BMC Infect. Dis.* 197 (2010).
- [20] Centers for Disease Control and Prevention (CDC), Guidelines for preventing the transmission of *Mycobacterium tuberculosis* in healthcare facilities, *MMWR* 43 (1994) 1–132.
- [21] Y. Yang, W.Y. Chan, C.L. Wu, R.Y.C. Kong, A.C.K. Lai, Minimizing the exposure of airborne pathogens by upper-room ultraviolet germicidal irradiation: an experimental and numerical study, *J. R. Soc. Interface* 9 (2012) 184–3195.
- [22] Y. Yang, A.C.K. Lai, R.Y.C. Kong, Q. Deng, Experimental and numerical study of the performance of upper room ultraviolet germicidal irradiation with the effective Z-value of airborne bacteria, *Aerosol Sci. Technol.* 51 (2017) 1123–1134.
- [23] M.S. Gangan, C.A. Athale, Threshold effect of growth rate on population variability of *Escherichia coli* cell lengths, *R. Soc. Open Sci.* 4 (2017) 160417.
- [24] A. Fàbrega, J. Vila, *Salmonella enterica* serovar typhimurium skills to succeed in the host: virulence and regulation, *Clin. Microbiol. Rev.* 26 (2013) 308–341.
- [25] P. Xu, J. Peccia, P. Fabian, J.W. Martyny, K.P. Fennelly, M. Hernandez, S.L. Miller, Efficacy of ultraviolet germicidal irradiation of upper-room air inactivating airborne bacterial spores and mycobacteria in full-scale studies, *Atmos. Environ.* 37 (2003) 405–419.
- [26] American Conference of Governmental Industrial Hygienists (ACGIH), Ultraviolet Radiation: TLV(R) Physical Agents 7th Edition Documentation, (2010).
- [27] World Health Organization. WHO Air Quality Guidelines for Particulate Matter, Ozone, Nitrogen Dioxide and Sulfur Dioxide, Global Update: Summary of Risk Assessment. Global Update (2005).
- [28] K. Yu, G.W. Lee, C. Hsieh, C. Lin, Evaluation of ozone generation and indoor organic compounds removal by air cleaners based on chamber tests, *Atmos. Environ.* 45 (2011) 35–42.

- [29] C. He, L. Morawska, H. Wang, R. Jayaratne, P. McGarry, G.R. Johnson, T. Bostrom, J. Gonthier, S. Authemayou, G. Ayoko, Quantification of the relationship between fuser roller temperature and laser printer emissions, *J. Aerosol Sci.* 41 (2010) 523–530.
- [30] M.S. Waring, J.A. Siegel, R.L. Corsi, Ultrafine particle removal and generation by portable air cleaners, *Atmos. Environ.* 42 (2008) 5003–5014.
- [31] S.L. Miller, J.M. Macher, Evaluation of a methodology for quantifying the effect of room air ultraviolet germicidal irradiation on airborne bacteria, *Aerosol Sci. Technol.* 33 (2000) 274–295.
- [32] W. Kowalski, *Ultraviolet Germicidal Irradiation Handbook:UVGI for Air and Surface Disinfection*, Springer, Heidelberg, Dordrecht, London, New York, 2009.
- [33] E.A. Nardell, S.J. Bucher, P.W. Brickner, C. Wang, R.L. Vincent, K. Becan-McBride, M.A. James, M. Michael, J.D. Wright, Safety of upper-room ultraviolet germicidal air disinfection for room occupants: results from the tuberculosis ultraviolet shelter study, *Public Health Rep.* 123 (2008) 52–60.
- [34] M. Mphahlele, A.S. Dharmadhikari, P.A. Jensen, S.N. Rudnick, T.H. van Reenen, M.A. Pagano, W. Leuschner, T.A. Sears, S.P. Milonova, M. van der Walt, A.C. Stoltz, K. Weyer, E.A. Nardell, Institutional tuberculosis transmission. Controlled trial of upper room ultraviolet air disinfection: a basis for new dosing guidelines, *Am. J. Respir. Crit. Care Med.* 192 (2015) 477–484.
- [35] S.N. Rudnick, M.W. First, Fundamental factors affecting upper-room ultraviolet germicidal irradiation —Part II. Predicting effectiveness, *J. Occup. Environ. Hyg.* 4 (2007) 352–362.
- [36] A.R. Escombe, D.A.J. Moore, R.H. Gilman, M. Navincopa, E. Ticona, B. Mitchell, C. Noakes, C. Martinez, P. Sheen, R. Ramirez, W. Quino, A. Gonzalez, J.S. Friedland, C.A. Evans, Upper-room ultraviolet light and negative air ionization to prevent tuberculosis transmission, *PLoS Med.* 6 (2009) 1–12.
- [37] P. Xu, E. Kujundzic, J. Peccia, M.P. Schafer, G. Moss, M. Hernandez, S.L. Miller, Impact of environmental factors on efficacy of upper-room air ultraviolet germicidal irradiation for inactivating airborne mycobacteria, *Environ. Sci. Technol.* 39 (2005) 9656–9664.
- [38] T.H. Dai, M.S. Vrahas, C.K. Murray, M.R. Hamblin, Ultraviolet C irradiation: an alternative antimicrobial approach to localized infections? *Expert Rev. Anti Infect. Ther.* 10 (2012) 185–195.
- [39] D.K. Kim, S.J. Kim, D.H. Kang, Bacterial effect of 266 to 279 nm wavelength UVC-LEDs for inactivation of gram positive and gram negative foodborne pathogenic bacteria and yeasts, *Food Res. Int.* 97 (2017) 280–287.
- [40] S.J. Kim, D.K. Kim, D.H. Kang, Using UVC light-emitting diodes at wavelengths of 266 to 279 nanometers to inactivate foodborne pathogens and pasteurize sliced cheese, *Appl. Environ. Microbiol.* 82 (2016) 11–17.
- [41] E. Gayan, M.J. Serrano, J. Raso, I. Alvarez, S. Condon, Inactivation of *Salmonella enterica* by UV-C light alone and in combination with mild temperatures, *Appl. Environ. Microbiol.* 78 (2012) 8353–8361.
- [42] G.B. Knudson, Photoreactivation of ultraviolet-irradiated, plasmid-bearing, and plasmid-free strains of *Bacillus anthracis*, *Appl. Environ. Microbiol.* 52 (1986) 444–449.