



Since January 2020 Elsevier has created a COVID-19 resource centre with free information in English and Mandarin on the novel coronavirus COVID-19. The COVID-19 resource centre is hosted on Elsevier Connect, the company's public news and information website.

Elsevier hereby grants permission to make all its COVID-19-related research that is available on the COVID-19 resource centre - including this research content - immediately available in PubMed Central and other publicly funded repositories, such as the WHO COVID database with rights for unrestricted research re-use and analyses in any form or by any means with acknowledgement of the original source. These permissions are granted for free by Elsevier for as long as the COVID-19 resource centre remains active.

Recombination and Coronavirus Defective Interfering RNAs

David A. Brian and Willy J. M. Spaan*

*Department of Microbiology, College of Veterinary Medicine, M409 Walters Life Sciences Building, University of Tennessee, Knoxville, Tennessee 37996-0845; and *Department of Virology, Institute of Medical Microbiology, Leiden University, 2300 RC Leiden, The Netherlands*

Naturally occurring defective interfering RNAs have been found in 4 of 14 coronavirus species. They range in size from 2.2 kb to approximately 25 kb, or 80% of the 30-kb parent virus genome. The large DI RNAs do not in all cases appear to require helper virus for intracellular replication and it has been postulated that they may on their own function as agents of disease. Coronavirus DI RNAs appear to arise by internal deletions (through nonhomologous recombination events) on the virus genome or on DI RNAs of larger size by a polymerase strand-switching (copy-choice) mechanism. In addition to their use in the study of virus RNA replication and virus assembly, coronavirus DI RNAs are being used in a major way to study the mechanism of a high-frequency, site-specific RNA recombination event that leads to leader acquisition during virus replication (i.e., the leader fusion event that occurs during synthesis of subgenomic mRNAs, and the leader-switching event that can occur during DI RNA replication), a distinguishing feature of coronaviruses (and arteriviruses). Coronavirus DI RNAs are also being engineered as vehicles for the generation of targeted recombinants of the parent virus genome. © 1997 Academic Press

KEY WORDS: RNA recombination; leader fusion; recombinant coronaviruses.

DISCUSSION

Recombination and the Origin of Coronavirus DI RNAs

Naturally occurring DI RNAs have been reported for the mouse hepatitis virus (MHV) (1–3), bovine coronavirus (BCV) (4), porcine transmissible gastroenteritis virus (TGEV) (5), and avian infectious bronchitis virus (IBV) (6). They range in size from 2.2 kb to approximately 25 kb, or close to the full length of the parental virus genome of nearly 30 kb. A survey of DI RNA structures indicates they are in all but one case a mosaic of linear segments of the virus genome and contain the genomic 5' and 3' termini (Fig. 1). In the large (~24 kb) DI ssA RNA of MHV (7) a rearrangement of sequence was found in which much of the leader, encoded by the virus genome 5' terminus, was also found internally on the DI RNA genome. Similarly

rearranged sequences (i.e., nonlinear with the parental virus genome) have been found in the genomes of virus recombinants (10, 11). In the absence of evidence supporting a splicing process in coronavirus RNA synthesis (12–14), the most likely mechanism for the origin of DI RNA, the one presumed in this review, appears to be template strand switching by the RNA polymerase from a donor template to an acceptor template of the same polarity during replication of a virus genome or of a previously formed DI RNA (15). It is unclear whether this happens during plus-strand or minus-strand synthesis. From the classification of copy-choice recombination patterns described by Lai (16), it will be recognized that the generation of DI RNA molecules must, in general, happen by nonhomologous recombination. That is, the switch between templates would take place between nonhomologous regions of the genome that demonstrate little or no sequence similarity. Although the general pattern in

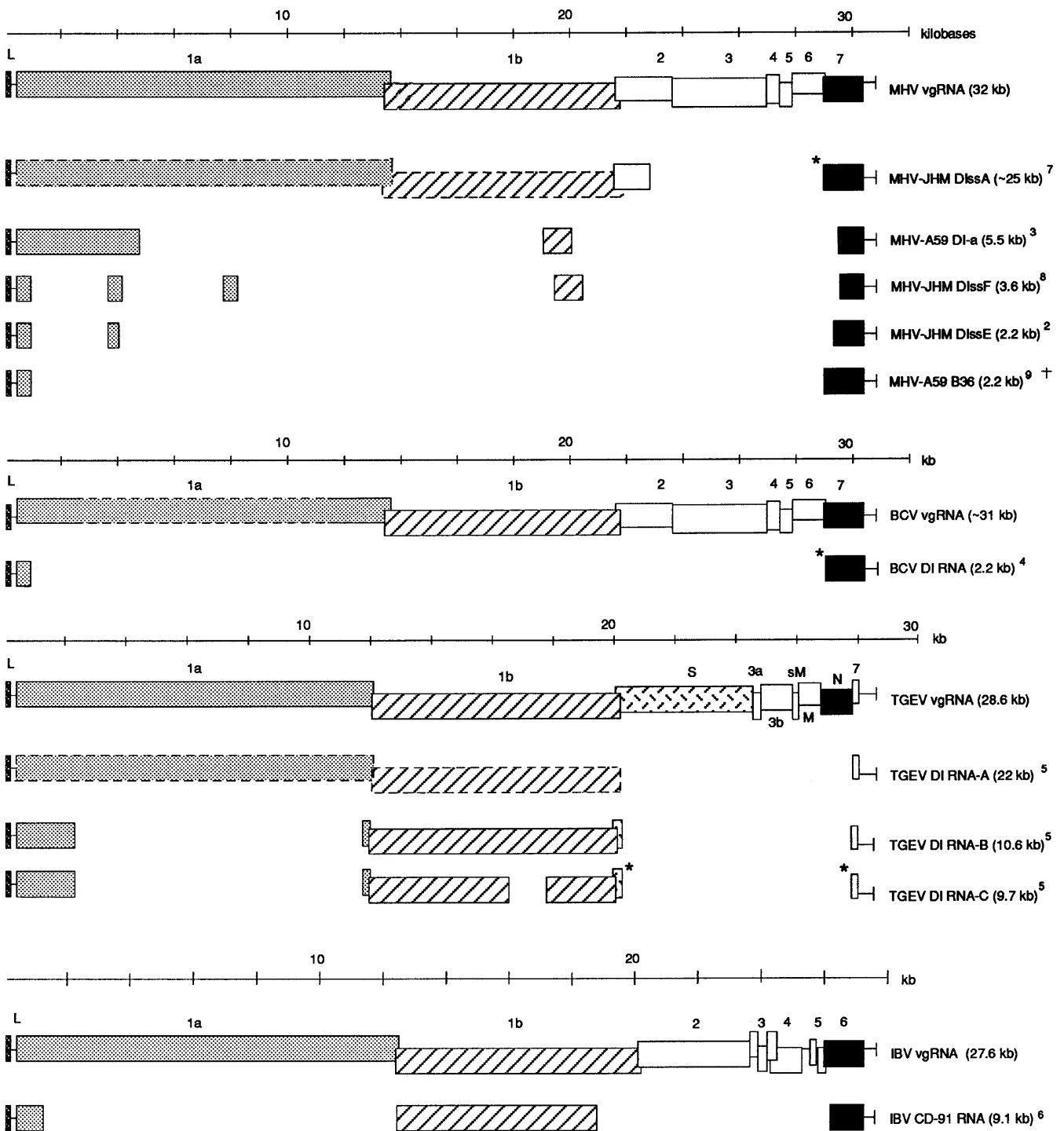

FIG. 1. Structures of the naturally occurring defective interfering RNAs identified in coronavirus-infected cells. Sequences found in DI RNAs are aligned with their place of origin on the parent virus genome (vgrNA). Boxes identify genes. The 5' and 3' untranslated regions are identified as narrow lines. The leader is identified by a box with heavy crosshatches. Regions not confirmed by sequencing are boxed by a dashed line. A synthetic DI RNA replicon for MHV-A59, B36 (9), patterned after the naturally occurring BCV DI RNA (4), is marked by a dagger. Asterisks identify recombination sites that occur within 27 nt of the UCUAAAC consensus intergenic sequence motif.

coronavirus DI RNA formation would suggest nonhomologous recombination, at some sites, short regions of sequence similarity may have directed polymerase reentry (for example, at intergenic consensus heptameric sequence motifs discussed below in the context of leader acquisition). Thus, in the microenvironment of the recombination site a short region of sequence identity might play a role in the mechanism of strand switching.

Biological Significance of Coronavirus DI RNAs

Many of the coronavirus DI RNAs appear to have the same attributes ascribed to DI RNAs of other RNA viruses (17–19), namely, the ability to competitively inhibit parental virus genome replication and to show a numerical abundance inversely related to that of the helper virus genome. Many (20–23), but not all (24, 25), have a requirement, or at least a preference, for translation *in cis* for replication. Those that become packaged (3–8, 26) also have the ability to be carried from cell to cell during virus infection and to possibly contribute to long-term virus persistence by attenuating cell damage caused by the helper virus.

An unusual property of some large coronavirus DI RNAs appears to be their ability to replicate without the aid of helper virus. At least one (7) and possibly more (27) large DI RNAs of MHV appear to be competent for independent replication, although this remains to be rigorously demonstrated by transfection with an isolated (or synthetic) DI RNA genome. Such a defective genome would necessarily retain the *cis*-acting elements for RNA replication and an active polymerase but may lack the function of one or more structural proteins needed for virus assembly. These molecules would, therefore, behave as RNA plasmids (replicons) and have the capacity to replicate continuously in infected cells and to express proteins that might contribute to a disease process. The persistence of replicating coronaviral RNA without infectious particle production in the encephalitic mouse brain (27) might be an example of this phenomenon. A report demonstrating persistence of MHV proteins and RNA in cell culture in the absence of infectious particle production (28) might be another example. Due to the high frequency of coronavirus recombination (29), large autoreplicating DI RNAs with pathogenic properties might be a common sequel of acute coronavirus infections and should be more generally looked for.

The Use of Coronavirus DI RNAs to Study the Mechanism(s) of Recombination in Coronavirus RNA: Coronavirus Leader Acquisition (during Either Leader Fusion or Leader Switching) Can Be Viewed as an Unusual Case of High-Frequency, Site-Specific RNA Recombination

Coronaviruses (12–30) and related arteriviruses (31), appear to stand alone among plus-strand RNA viruses in their possession of a leader sequence, encoded only at the genomic 5' terminus, that becomes the 5' terminus of each subgenomic mRNA. The presence of a 7-nt consensus sequence motif at the 3' end of the genomic leader (UCUAAAC for MHV and BCV, ACUAAAC for TGEV, and CUUAACA for IBV) and at intergenic regions on the virus genome has suggested a sequence-directed leader fusion event during RNA synthesis (12–14, 30). UV inactivation of transcription in MHV (32, 33) has demonstrated that subgenomic mRNA transcripts do not arise from precursors of genome size, indicating that there is probably no intramolecular splicing (i.e., cutting and rejoining) of genome-length precursor molecules. The leader fusion event during subgenomic mRNA synthesis, therefore, in the absence of any demonstrated splicing, must be viewed as one that happens as the result of a discontinuous RNA-synthesizing mechanism (34, 35). A similar (and perhaps in many ways identical) leader fusion event happens during a high-frequency leader-switching process on the 5' terminus of transfected DI RNA templates (36, 37). Both processes of leader fusion, therefore, must be viewed as one of RNA recombination since they involve, by necessity, donor and acceptor templates. The leader fusion event would likewise necessarily be one of extremely high frequency and site specificity were it to happen during the synthesis of each and every new mRNA molecule or, alternatively, during the synthesis of every new mRNA template (depending on the mechanism of coronavirus transcription). This event is not to be confused (except possibly in a mechanistic sense) with what is described as high-frequency homologous recombination between coronavirus genomes (16, 29). The latter has an incidence of 25% throughout the genome per virus generation time (16) and may occur more or less randomly throughout the genome (38). Phenomenologically, the high-frequency, site-specific recombination event associated with leader acquisition bears some resemblance to the mandatory strand-switching steps carried out by reverse transcriptase in the early steps of retrovirus replication (39).

Two developments with coronavirus DI RNAs have established manipulable systems with which the mechanism of leader recombination might be examined. First, it has been learned that the UC₃AAAC promoter sequence, or its variants with differing lengths of flanking sequence, could be placed within the 5' UTR (40) the ORF (41–45), or within the 3' UTR (46) of the DI RNA and direct synthesis of subgenomic DI RNA transcripts. Second, it has been observed that the leader on DI RNA replicons is rapidly replaced by the leader of the helper virus after transfection into helper virus-infected cells (4, 36, 37).

Two major models have been put forward to explain the high-frequency, site-specific RNA recombination process that accompanies leader acquisition, both of which are being approached through the study of DI RNAs. One postulates a polymerase strand switching during plus-strand RNA synthesis (i.e., during synthesis of subgenomic mRNAs (34, 35, 47), virus genome (48), or DI RNAs (37), and the other during minus-strand synthesis (i.e., during synthesis of templates for mRNAs (49) or DI RNAs (4, 36). These are summarized in Fig. 2.

The Model of Leader Acquisition during Plus-Strand Synthesis

The original postulate (34, 35) to mechanistically explain leader acquisition held that the plus-strand leader functions as a primer for synthesis of the subgenomic mRNA molecule during transcription from a genome-length minus-strand template (Fig. 2A1). In this scheme, leader sequences are made, probably in excess, and are, by a process of discontinuous, nonprocessive synthesis, translocated (possibly in a complex with the polymerase) to distant sites on the minus-strand template. It was postulated that the priming was directed by base-pairing between the UC₃AAAC element within the free leader and complementary promoter sequences on the minus-strand template (58), or by protein–RNA (40, 46) or protein–protein interactions between proteins that recognize these elements (45, 59). Since leader-containing transcripts that might function as free leaders are longer than the leader itself (i.e., >80 nt) (34) and crossover sites map within or even upstream of the UC₃AAAC promoter, the action of a 3' → 5' exonuclease was postulated for the trimming of the primer before continuation of RNA synthesis (46, 51). A most intriguing discovery regarding leader fusion was that despite the general overall high degree of site specificity observed during leader

recombination, at times, and at specific junctions, widely variant leader–mRNA junction sequences could be found (40, 50). These included junctions with either fewer or more UC₃AA elements than are found in the 5' genomic leader. This phenomenon was interpreted by the leader priming model to mean that the multiple UC₃AA-containing elements within the MHV leader (i.e., the UC₃AA (5-nt) promoter-like sequences just upstream of the leader UC₃AAAC (7-nt) element and the UUUAUAAAC (9-nt) leader-flanking element just downstream) could provide optional leader priming sites for transcription initiation (Figs. 3A, 3B) (52). Optional priming sites, however, cannot explain all of the variations observed at leader–mRNA junctions. For example, in MHV it was noted that when the UUUAUAAAC 9-nt leader-flanking element was missing from a natural virus mutant, sequences of unknown origin would also be placed at the leader–mRNA junction (40). Furthermore, no variation has been found in transcripts from the MHV mRNA₃ promoter, which contains only a single UC₃AA element despite the existence of multiple UC₃AA motifs in the leader (46). In BCV, where only a single UC₃AA element exists in both the genomic leader and at each intergenic site, no variant junction sequences have been found, which is consistent with the idea that the multiple UC₃AA motifs in MHV contribute to variable leader–mRNA junction structures (60). With the demonstration that transcripts of cloned DI RNA can undergo replication in helper virus-infected cells, it was observed that transfected DI RNA possessing one type of leader sequence rapidly lost this leader and acquired (within one cycle of virus replication) the leader of the helper virus (37). This phenomenon was described as leader switching (37). As with the variant patterns of leader–mRNA junction sequences, and leader–genome junction sequences, variant patterns of leader–DI RNA junctions suggested alternative leader priming locations on the promoter sequence. From this observation it was postulated that perhaps replication of DI RNA (and by extension, possibly genomic RNA) was a leader-primed transcription event (Fig. 2A2) (52).

The leader-priming model, therefore, whether it be applied to leader fusion during subgenomic mRNA synthesis or to leader switching, describes a recombination event that requires a free leader, long-distance polymerase jumping (assuming the leader remains attached to the polymerase), and a 3' → 5' exonuclease activity to trim the excess leader sequence before resumption of RNA synthesis.

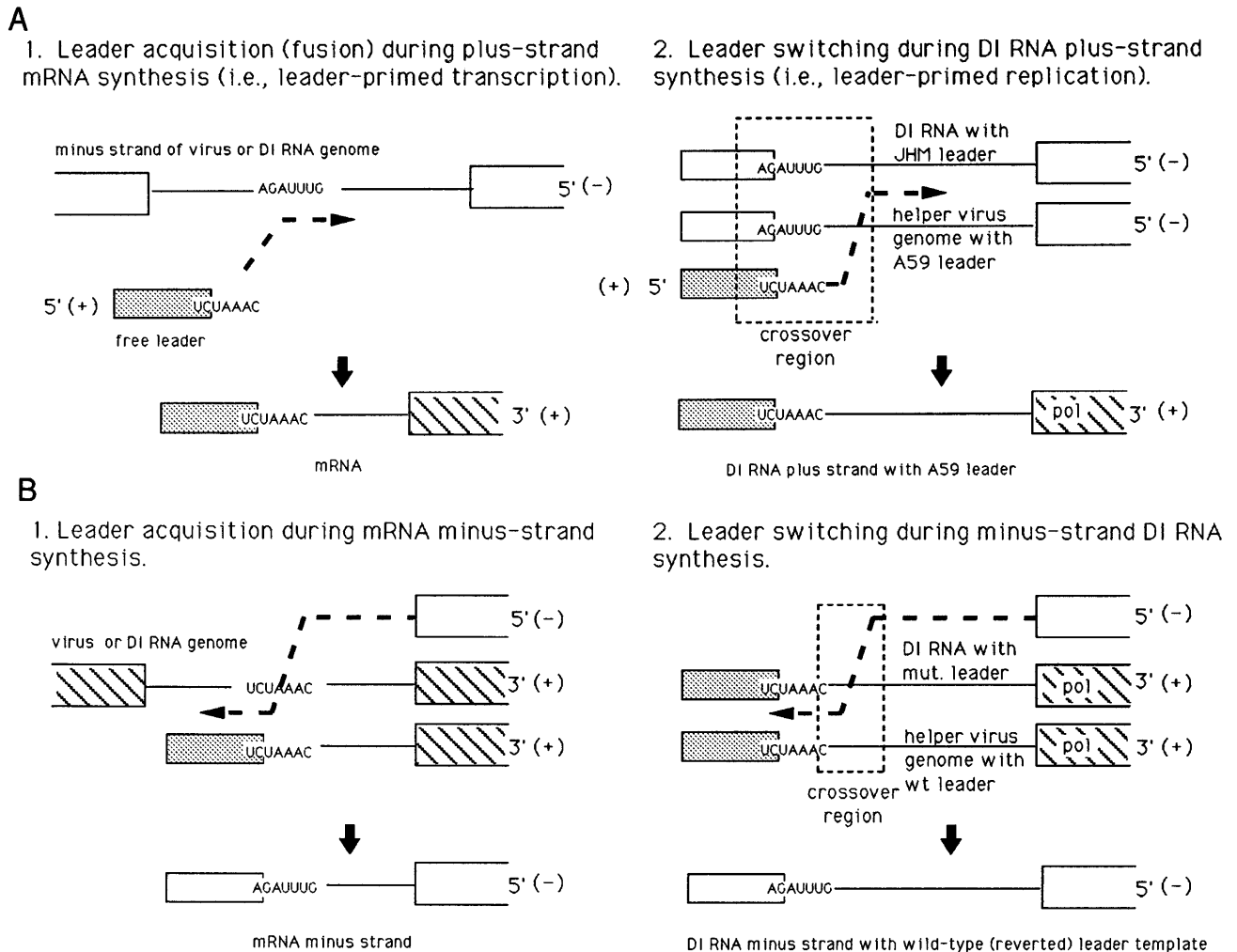

FIG. 2. Polymerase strand-switching models for the high-frequency, site-specific leader recombination events accompanying coronavirus leader acquisition. (A) Model for leader acquisition during plus-strand RNA synthesis (i.e., the leader-priming model). (A,1) The model for leader-primed transcription postulates that leader, synthesized from the 3' end of genome minus-strand RNA, becomes translocated to the intergenic priming site (AGAUUUG) on virus genome minus strand to prime transcription (29, 34, 35). By this model, any of the UCUAA sequence motifs within the MHV free leader can serve as alternate alignment sequences (35, 50), and extra 3'-terminal sequences on the annealed leader are trimmed by a 3' → 5' exonuclease to a region within the UCUAAAAC intergenic sequence motif (45, 51). (A,2). Model for leader switching during DI RNA plus-strand RNA synthesis (i.e., leader-primed replication). This model is nearly identical to that in A,1 except that the nascent leader synthesized must translocate to another template for priming of transcription *in trans* (37), and the UAUAAAAC sequence, which is part of a UUUUAUAAAAC 9-nt motif, can serve as a donor site on the free leader (52). A potential crossover region can be inferred from these data. (B) Models for leader acquisition during minus-strand RNA synthesis. (B,1) Model for leader acquisition during mRNA minus-strand synthesis. This model postulates that polymerase is attenuated at the UCUAAAAC sequence during synthesis of the subgenomic minus-strand RNA template and switches to a plus-strand leader template to complete synthesis of the subgenomic minus-strand RNA template (49, 53). In theory, the plus-strand leader template could be supplied by the genome 5' terminus (this would be necessary if this were the only plus-strand molecule present at the time of initial infection, say with a single infectious genome) (49, 53) or by another mRNA molecule (36, 43). The mRNA minus strand would then be a template for mRNA amplification (49, 54–57) (B,2). Model for leader switching during minus-strand DI RNA synthesis. This model is nearly identical to that in B,1 except that the polymerase strand switching occurs near the UCUAAAAC intergenic motif at the 5' end of the genome (36). For BCV, a potential crossover region has been identified (36) (see Fig. 3). The UCUAAAAC sequence on the template is not required for the leader switching to occur (36). The model in B does not require the use of a 3' → 5' exonuclease activity for trimming or for a nonprocessive property of the RNA-dependent RNA polymerase.

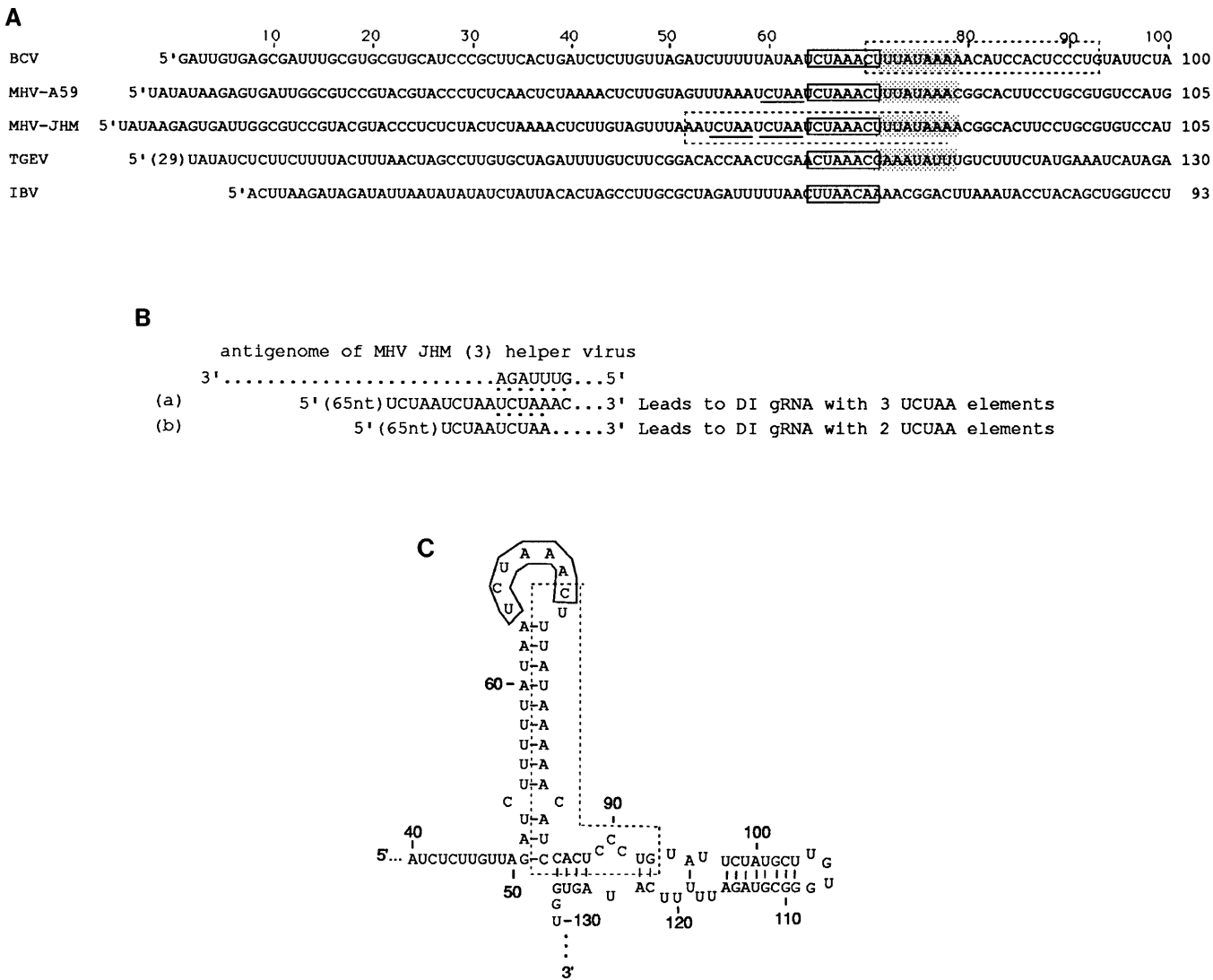

FIG. 3. RNA structures surrounding the crossover regions for leader switching. (A) A portion of the 5' untranslated regions of BCV, MHV-A59, MHV-JHM, TGEV, and IBV DI RNAs are shown aligned by the heptameric intergenic sequence motif. The intergenic motifs are boxed with a solid line. The additional UCUAA elements in MHV are underlined. The AU-rich palindromic sequences are shaded. The regions within which high-frequency crossover is observed during leader switching for BCV (36) and MHV are boxed with a dashed line. High-frequency leader switching has not yet been described for TGEV and IBV DI RNAs. (B) Proposed alternate alignments in the leader priming model that would give rise to variant MHV DI RNA leader junctions (52). (C) Stem-loop structures near the leader crossover region in BCV DI RNA (36). Note that the UCUAAC intergenic sequence element is in the loop of a stem-loop (boxed with a solid line). The crossover window is boxed with a dashed line.

The Model of Leader Acquisition during Minus-Strand Synthesis

An alternative hypothesis for explaining leader acquisition during mRNA synthesis states that the high-frequency site-specific recombination event occurs during minus-strand synthesis of subgenomic mRNA templates (Fig. 2B1) (49, 53). This model arose from data showing the existence of mRNA-length minus-

strands RNAs (54, 57) that possess a complement of the leader sequence (56) and that are active in subgenomic mRNA synthesis (49, 55). It follows that the UCUAAC intergenic elements serve as attenuators of polymerase synthesis during minus-strand synthesis and promote polymerase strand switching to copy a leader supplied *in cis* by the 5' end of the genome (53), or possibly *in trans* by another mRNA (36, 43), to

generate a leader template for synthesis of subgenomic mRNAs. A component of this model is that RNA synthesis during polymerase strand switching need not necessarily be dispersive (nonprocessive), i.e., the polymerase could attach to the second template without necessarily detaching from the first (a mechanism described in reference 61). It might also be that strand switching could occur at various sites within the intergenic sequence motif, thereby explaining why all mutations within the intergenic sequence are not retained in subgenomic mRNAs (42, 46). The second model, therefore, in contrast to the first, does not require that there be a free leader (and thus a mechanism to discriminate between free leader synthesis and genomic RNA synthesis), long-distance polymerase jumping (i.e., nonprocessive synthesis), or a 3' → 5' exonuclease processing of the leader during the crossover event.

This model, with some variation, can also explain leader switching between the 5' terminus of DI RNA and helper virus genome (Fig. 2B2) (36). In a recent series of experiments to examine the role of the UCUAAC element in leader switching, mutations in and around the leader and its flanking sequences were made on the BCV DI RNA, including deletion of the UCUAAC element, and tested for leader switching (36). Leader switching was not deterred when the UCUAAC element was missing, suggesting that other elements were directing the sequence alignments. Crossover sites were found largely downstream of the UCUAAC element and a potential crossover window was mapped (Figs. 3A and 3C) (36).

It has also been suggested that the leader-priming model and the strand-switching during minus-strand synthesis model need not be mutually exclusive (14). It could be, for example, that a free leader would prime plus-strand synthesis from a minus-strand template whose synthesis had been truncated after passing through the intergenic sequence (see model B, p. 18 in reference 14).

The contrasting models help to raise focused questions on the mechanism of this site-specific recombination event. (i) To what extent can free leader molecules be found in cells infected with coronaviruses other than MHV? How can it be explained, for example, that apparent free leader species are found in MHV (34) but not in BCV-infected (36) cells? If free leaders do exist for other coronaviruses, what are the common features among them? Are they complexed with other molecules and what directs them to template priming sites? (ii) Precisely, what are the RNA structural fea-

tures at leader recombination sites that direct the site specificity? Using DI RNAs with experimentally arranged intergenic sequence motifs, the roles of both RNA secondary structure and intergenic element positioning within the DI RNA have been examined as influences on site specificity and frequency of the fusion event (41–45, 62, 63). Other than the demonstration in MHV that the UCUAAC is the minimal element required to direct leader fusion (42, 44), no consensus on what structural features are required for site specificity or for frequency of use has emerged. Based on recent analyses showing the importance of RNA stem-loops in directing site-specific RNA recombination in turnip crinkle virus (64) and tomato bush stunt virus (65), might it be that 2° structures are important in coronavirus leader recombination? An analysis of leader switching in BCV DI RNA (36) shows the crossover window to be along a stem and near the base of a stem-loop structure (Fig. 3C). Other structural features may also be important, however, including the relatively AU-rich region occurring just downstream of the crossover sites. AU-rich regions have been shown to influence the accuracy of crossover sites in brome mosaic virus recombination (66, 67). In BCV and MHV, the AU-rich region includes the UUUAUAAA palindrome (as ds RNA), or in TGEV the AAAUAUUU sequence. This motif does not occur in IBV, however. Furthermore, the UUUAUAAA-containing UUUAUAAAC 9-nt motif occurring just downstream of the MHV leader (Fig. 3A) has been shown to exert a powerful influence on the process of leader switching (37) and on the formation of the leader fusion sites *in cis* or *in trans* in MHV (68). This element is often missing in replicating MHV DI RNAs (37), but in BCV, the UUUAUAAA palindromic portion of this sequence is absolutely required for DI RNA replication (36). How is it that the UUUAUAAA palindromic sequence is required for replication of BCV DI RNA but not MHV DI RNA? In this regard, do TGEV and IBV exhibit leader switching? If so, is it dependent on the palindromic or other AU-rich regions? Are the variant leader-mRNA sequences for MHV, but not found in BCV, related solely to the leader content of multiple UCUAAC elements in the MHV genome? (iii) To what extent can transfected molecules be made to recombine precisely at leader fusion sites? A powerful tool in the study of leader acquisition has been the demonstration that transfected leader-containing oligonucleotides can be shown to act *in trans* during RNA synthesis (51, 69). Can this be shown as well for DI RNAs? What structural features on the oligonucleotides direct this process? To what extent do these

molecules become associated with viral and cellular proteins or enter the replication complex?

Is the Recombination Mechanism That Is Used for Leader Acquisition Mechanistically Related to DI RNA Formation?

It has been suggested previously that the high frequency of coronavirus recombination (both homologous and aberrant homologous recombination giving rise to recombinant coronaviruses and nonhomologous recombination giving rise to DI RNA formation) might reflect the mechanism of discontinuous transcription used by coronaviruses in the generation of leader-containing subgenomic mRNA species (i.e., perhaps the polymerase has the "promiscuous" properties of easily switching template strands during a copy-choice synthesis) (12, 16, 35). An examination of the coronavirus DI RNAs depicted in Fig. 1 would suggest that testing this idea would be difficult at this time since formation of DI RNAs shows no predictable pattern and there is little evidence that intergenic crossover sites are used frequently in the formation of DI RNAs. Of the 38 crossover sites observed (Fig. 1), only 4 occur very near (within 27 nt) intergenic consensus sequence sites, and curiously, of these, the most 3' terminal fusion site in TGEV DI RNA B (5) and MHV DIssA (7) shows a high degree of sequence hypervariability with respect to base deletions (5) and sequence rearrangements (7). Therefore, except for leader fusion, site specificity in DI RNA recombination cannot be experimentally induced, making elucidation of mechanisms of DI RNA formation difficult. Perhaps recent technical developments such as the ability to generate DI RNA replicons from defined *in vitro*-synthesized minus-strand RNA molecules (70) will allow for a more sophisticated analysis of DI RNA formation.

Use of DI RNAs to Produce Targeted Coronavirus Genome Recombinants

In addition to the demonstration that transfected nonreplicating sequences containing the coronavirus leader (51, 69) (or antileader (69)) can be the donor source for a recombinant viral genome or DI RNA within the 5' untranslated region, it has been shown that a transfected, synthetic nonreplicating mRNA can be the donor source for intragenic recombination within the virus genome (71). This was demonstrated for the N (the most 3') gene of MHV, in which an 87-nt

deletion in the N gene causing a temperature-sensitive phenotype in the helper virus (Alb4) was repaired upon transfection with a wild-type mRNA (71). Recombinant progeny viruses were selected at a frequency of approximately 10^{-5} . Two groups have subsequently demonstrated that the rate of intragenic (N gene) recombination with virus genome can be increased by two orders of magnitude when the donor molecule for recombination was in the genome of a replicating DI RNA (9, 72, 73). These experiments suggest that the recombination process could be linked to RNA synthesis and support the notion for a copy-choice mechanism of coronavirus RNA recombination.

Still more recent experiments have demonstrated that interspecies chimeric N genes (74) and intraspecies S genes (75) can be produced by targeted recombination when an engineered DI RNA replicon carries the donor sequence. This establishes the feasibility for site-specific mutagenesis of the coronavirus genome and for preparing chimeric coronavirus genomes with foreign genes despite an inability at the present time to construct full-length cDNA clones of the coronavirus genome. In principle, foreign gene sequences could be targeted to any given region of the genome as long as the appropriate flanking sequences are used.

Long-Range Questions Concerning Coronavirus DI RNAs and Recombination

What is the evolutionary pressure for development and retention of the leader recombination mechanism in coronaviruses? Might it be that the leader provides a translational advantage for viral mRNAs (76) and hence a pressure for selection? In this regard, how do the toroviruses, a second genus in the coronavirus family, function without a leader if, in fact, they have none? How might DI RNAs of toroviruses (77) and arteriviruses be used to facilitate examination of this question? How might the newly described infectious transcripts of the cloned 12-kb genome of arterivirus be used for elucidating the mechanism of leader acquisition (78)? How might new methods of generating defined coronavirus DI RNA particles (79) be used for the analysis of recombination mechanisms and for the generation of new virus recombinants?

CONCLUSIONS

In lieu of a full-length coronavirus cDNA clone capable of generating infectious transcripts, coronavi-

rus DI RNAs are being used to study the mechanisms of recombination in this virus family. Much of the work with DI RNAs thus far has focused on the intriguing phenomenon of extremely high-frequency, site-specific leader recombination (i.e., leader fusion or leader switching) that accompanies coronavirus RNA synthesis for which there is no consensus on mechanism. DI RNAs are also being used as vectors to generate recombinant virus genomes by targeted homologous RNA recombination and to study the mechanism of these events. It remains to be determined what mechanistic features are shared between the processes of leader acquisition and the formation of virus recombinants and DI RNAs.

ACKNOWLEDGMENTS

D.B. is supported by Grant 92-37204-8046 from the United States Department of Agriculture and Grant AI 14367 from the National Institutes of Health.

REFERENCES

- Makino, S., Fujioka, N., and Fujiwara, K. (1985) Structure of the intracellular defective viral RNAs of defective interfering particles of mouse hepatitis virus. *J. Virol.* **54**, 329–336.
- Makino, S., Shieh, C.-K., Soe, L. H., Baker, S. C., and Lai, M. M. C. (1988) Primary structure and translation of a defective interfering RNA of murine coronavirus. *Virology* **166**, 550–560.
- van der Most, R. G., Bredenbeek, P. J., Spaan, W. J. M. (1991) A domain at the 3' end of the polymerase gene is essential for encapsidation of coronavirus defective interfering RNAs. *J. Virol.* **65**, 3219–3226.
- Chang, R. Y., Hofmann, M. A., Sethna, P. B., and Brian, D. A. (1994) A cis-acting function for the coronavirus leader in defective-interfering RNA replication. *J. Virol.* **68**, 8223–8231.
- Mendez, A., Smerdou, C., Izeta, A., Gebauer, F., and Enjuanes, L. (1996) Molecular characterization of transmissible gastroenteritis coronavirus defective interfering genomes: Packaging and heterogeneity. *Virology* **217**, 495–507.
- Penzes, Z., Tibbles, K., Shaw, K., Britton, P., Brown, T. D. K., and Cavanagh, D. (1994) Characterization of a replicating and packaged defective RNA of avian coronavirus infectious bronchitis virus. *Virology* **203**, 286–293.
- Kim, K. H., and Makino, S. (1995) Two murine coronavirus genes suffice for viral RNA synthesis. *J. Virol.* **69**, 2313–2321.
- Makino, S., Yokomori, K., and Lai, M. M. C. (1990) Analysis of efficiently packaged defective interfering RNAs of murine coronavirus: Localization of a possible RNA-packaging signal. *J. Virol.* **64**, 6045–6053.
- Masters, P., Koetzner, C. A., Kerr, C. A., and Heo, Y. (1994) Optimization of targeted RNA recombination and mapping of a novel nucleocapsid gene mutation in coronavirus mouse hepatitis virus. *J. Virol.* **68**, 328–337.
- Mounir, S., and Talbot, P. J. (1993) Human coronavirus OC43 RNA 4 lacks two open reading frames located downstream of the S gene of bovine coronavirus. *Virology* **192**, 355–360.
- Taguchi, F., Ikeda, T., Makino, S., and Yoshikura, H. (1994) A murine coronavirus MHV-S isolate from persistently infected cells has a leader and two consensus sequences between the M and N genes. *Virology* **198**, 355–359.
- Lai, M. M. C. (1990) Coronavirus: Organization, replication, and expression of genome. *Annu. Rev. Microbiol.* **44**, 303–333.
- Spaan, W., Cavanagh, D., and Horzinek, M. C. (1988) Coronaviruses: Structure and genome expression. *J. Gen. Virol.* **69**, 2939–2952.
- van der Most, R. G., and Spaan, W. J. M. (1995) Coronavirus replication, transcription, and RNA recombination. In *The Coronaviridae* (S. G. Siddell, Ed.), pp. 11–31. Plenum Press, London.
- Furuya, T., Macnaughton, T. B., La Monica, N., and Lai, M. M. C. (1993). Natural evolution of coronavirus defective-interfering RNA involves RNA recombination. *Virology* **194**, 408–413.
- Lai, M. M. C. (1992). RNA recombination in animal and plant viruses. *Microbiol. Rev.* **56**, 61–79.
- Holland, J. (1991) Defective viral genomes. In *Fundamental Virology* (B. N. Fields and D. M. Knipe, Eds.), pp. 151–165. Raven Press, New York.
- King, A. M. Q. (1988) Genetic recombination in positive strand RNA viruses. In *RNA Genetics* (E. Domingo, J. J. Holland, and P. Ahlquist, Eds.), Vol. II, pp. 149–165. CRC Press, Boca Raton, FL.
- Schlesinger, S. (1988) The generation and amplification of defective interfering RNAs. In *RNA genetics* (E. Domingo, J. J. Holland, and P. Ahlquist, Eds.), Vol. II, pp. 167–185. CRC Press, Boca Raton, FL.
- Chang, R. Y., and Brian, D. A. (1996) Cis-requirement for N-specific protein sequence in bovine coronavirus defective interfering RNA replication. *J. Virol.* **70**, 2201–2207.
- de Groot, R. J., van der Most, R. G., and Spaan, W. J. M. (1992) The fitness of defective interfering murine coronavirus DI-a and its derivatives is decreased by nonsense and frameshift mutations. *J. Virol.* **66**, 5898–5905.
- Kim, Y. N., Lai, M. M. C., and Makino, S. (1993) Generation and selection of coronavirus defective interfering RNA with large open reading frame by RNA recombination and possible editing. *Virology* **194**, 244–253.
- van der Most, R. G., Luytjes, W., Rutjes, S., and Spaan, W. J. M. (1995) Translation but not the encoded sequence is essential for the efficient propagation of the defective interfering RNAs of the coronavirus mouse hepatitis virus. *J. Virol.* **69**, 3744–3751.
- Liao, C. L., and Lai, M. M. C. (1995) A cis-acting viral protein is not required for the replication of a coronavirus defective-interfering RNA. *Virology* **209**, 428–436.
- Penzes, Z., Wroe, C., Brown, T. D. K., Britton, P., and Cavanagh, D. (1996) Replication and packaging of coronavirus infectious bronchitis virus defective RNAs lacking a long open reading frame. *J. Virol.* **70**, 8660–8668.
- Fosmire, J. A., Hwang, K., and Makino, S. (1992) Identification and characterization of a coronavirus packaging signal. *J. Virol.* **66**, 3522–3530.
- Adami, C., Pooley, J., Glomb, J., Stecker, E., Fazal, F., Fleming, J. O., and Baker, S. C. (1995) Evolution of mouse hepatitis virus (MHV) during chronic infection: Quasispecies nature of the persisting MHV RNA. *Virology* **209**, 337–346.
- Maeda, A., Hayashi, M., Ishida, K., Mizutani, T., Watanabe, T., and Namioka, S. (1995) Characterization of DBT cell clones

- derived from cells persistently infected with the JHM strain of mouse hepatitis virus. *J. Vet. Med. Sci.* **57**, 813–817.
29. Makino, S., Keck, J. G., Stohman, S. A., and Lai, M. M. C. (1986) High frequency recombination of murine coronaviruses. *J. Virol.* **57**, 729–737.
 30. Holmes, K. V., and Lai, M. M. C. (1996) Coronaviridae: The viruses and their replication. In *Virology* (B. N. Fields, D. M. Knipe, and P. M. Howley, Eds.), Vol. 1, Chap. 34. Lippincott-Raven, Philadelphia, PA.
 31. de Vries, A. A. F., Chirnside, E. D., Bredenbeek, P. J., Gravestien, L. A., Horzinek, M. C., and Spaan, W. J. M. (1990) All subgenomic mRNAs of equine arteritis virus contain a common leader sequence. *Nucleic Acids Res.* **18**, 3241–3247.
 32. Jacobs, L., Spaan, W. J. M., Horzinek, M. C., and van der Zeijst, B. A. M. (1981) Synthesis of subgenomic mRNAs of mouse hepatitis virus is initiated independently: Evidence from UV transcription mapping. *J. Virol.* **39**, 401–406.
 33. Yokomori, K., Banner, L. R., and Lai, M. M. C. (1992) Coronavirus mRNA transcription: UV light transcriptional mapping studies suggest an early requirement for a genome-length template. *J. Virol.* **66**, 4671–4678.
 34. Baric, R. S., Stohman, S. A., and Lai, M. M. C. (1983) Characterization of replicative intermediate RNA of mouse hepatitis virus: Presence of leader RNA sequences on nascent chains. *J. Virol.* **48**, 633–640.
 35. Spaan, W., Delius, H., Skinner, M., Armstrong, J., Rottier, P., Smeekens, S., van der Ziejst, B. A., and Siddell, S. G. (1983) Coronavirus mRNA synthesis involves fusion of non-contiguous sequences. *EMBO J.* **2**, 1839–1844.
 36. Chang, R. Y., Krishnan, R., and Brian, D. A. (1996) The UCU-AAAC promoter motif is not required for high-frequency leader recombination in bovine coronavirus defective interfering RNA. *J. Virol.* **70**, 2720–2729.
 37. Makino, S., and Lai, M. M. C. (1989) High-frequency leader sequence switching during coronavirus defective interfering RNA replication. *J. Virol.* **63**, 5285–5292.
 38. Banner, L. R., and Lai, M. M. C. (1991) Random nature of coronavirus RNA recombination in the absence of selection pressure. *Virology* **185**, 441–445.
 39. Coffin, J. M. (1996) Retroviridae: The viruses and their replication. In *Virology* (B. N. Fields, D. M. Knipe, and P. M. Howley, Eds.), Vol. 2, Chap. 58. Lippincott-Raven, Philadelphia, PA.
 40. Zhang, X., and Lai, M. M. C. (1994) Unusual heterogeneity of leader-mRNA fusion in a murine coronavirus: Implications for the mechanism of RNA transcription and recombination. *J. Virol.* **68**, 6626–6633.
 41. Jeong, Y. S., Repass, J. F., Kim, Y. N., Hwang, S. M., and Makino, S. (1996) Coronavirus transcription mediated by sequences flanking the transcription consensus sequence. *Virology* **217**, 311–322.
 42. Joo, M., and Makino, S. (1992) Mutagenic analysis of the coronavirus intergenic consensus sequence. *J. Virol.* **66**, 6330–6337.
 43. Krishnan, R., Chang, R. Y., and Brian, D. A. (1996) Tandem placement of a coronavirus promoter results in enhanced mRNA synthesis from the downstream-most initiation site. *Virology* **218**, 400–405.
 44. Makino, S., and Joo, M. (1993) Effect of intergenic consensus flanking sequences on coronavirus transcription. *J. Virol.* **67**, 3304–3311.
 45. van Marle, G., Luytjes, W., van der Most, R. G., van der Straaten, T., and Spaan, W. J. (1995) Regulation of coronavirus mRNA transcription. *J. Virol.* **69**, 7851–7856.
 46. van der Most, R. G., DeGroot, R. J., and Spaan, W. J. M. (1994) Subgenomic RNA synthesis directed by a synthetic defective interfering RNA of mouse hepatitis virus: A study of coronavirus transcription initiation. *J. Virol.* **68**, 3656–3666.
 47. Makino, S., Stohman, S., and Lai, M. M. C. (1986) Leader sequence of murine coronavirus mRNAs can be freely reassorted: Evidence for the role of free leader RNA in transcription. *Proc. Natl. Acad. Sci. USA* **83**, 4202–4208.
 48. Makino, S., and Lai, M. M. C. (1989) Evolution of the 5'-end of genomic RNA of murine coronaviruses during passages in vitro. *Virology* **169**, 227–232.
 49. Sawicki, S. G., and Sawicki, D. L. (1990) Coronavirus transcription: Subgenomic mouse hepatitis virus replicative intermediates function in mRNA synthesis. *J. Virol.* **64**, 1050–1056.
 50. Shieh, C. K., Soe, L. H., Makino, S., Chang, M. F., Stohman, S. A., and Lai, M. M. C. (1987) The 5'-end sequence of the murine coronavirus genome: Implications for multiple fusion sites in leader-primed transcription. *Virology* **156**, 321–330.
 51. Baker, S. C., and Lai, M. M. C. (1990) An in vitro system for the leader-primed transcription of coronavirus mRNAs. *EMBO J.* **9**, 4173–4179.
 52. Zhang, X., and Lai, M. M. C. (1996) A 5'-proximal sequence of murine coronavirus as a potential initiation site for genomic-length mRNA transcription. *J. Virol.* **70**, 705–711.
 53. Sawicki, S. G., and Sawicki, D. L. (1995) Coronaviruses use discontinuous extension for synthesis of subgenome-length negative strands. In *Corona- and Related Viruses* (P. J. Talbot, and G. A. Levy, Eds.), pp. 499–506. Plenum, New York.
 54. Hofmann, M. A., Sethna, P. B., and Brian, D. A. (1990) Bovine coronavirus mRNA replication continues throughout persistent infection in cell culture. *J. Virol.* **64**, 4108–4114.
 55. Schaad, M. C., and Baric, R. S. (1994) Genetics of mouse hepatitis virus transcription: Evidence that subgenomic negative strands are functional templates. *J. Virol.* **68**, 8169–8179.
 56. Sethna, P. B., Hofmann, M. A., and Brian, D. A. (1991) Minus-strand copies of replicating coronavirus mRNAs contain antileaders. *J. Virol.* **65**, 320–325.
 57. Sethna, P. B., Hung, S.-L., and Brian, D. A. (1989) Coronavirus subgenomic minus-strand RNA and the potential for mRNA replicons. *Proc. Natl. Acad. Sci. USA* **86**, 5626–5630.
 58. Budzilowicz, C. J., Wilczynski, S. P., and Weiss, S. R. (1985) Three intergenic regions of coronavirus mouse hepatitis virus strain A59 genome RNA contain a common nucleotide sequence that is homologous to the 3' end of the viral mRNA leader sequence. *J. Virol.* **53**, 834–840.
 59. Zhang, X., and Lai, M. M. C. (1995) Interactions between the cytoplasmic proteins and the intergenic (promoter) sequence of mouse hepatitis virus RNA: Correlation with the amounts of subgenomic mRNA transcribed. *J. Virol.* **69**, 1637–1644.
 60. Hofmann, M. A., Chang, R. Y., Ku, S., and Brian, D. A. (1993) Leader-mRNA junction sequences are unique for each subgenomic mRNA species in the bovine coronavirus and remain so throughout persistent infection. *Virology* **196**, 163–171.
 61. Jarvis, T. C., and Kirkegaard, K. (1991) The polymerase in its labyrinth: Mechanisms and implications of RNA recombination. *Trends Genet.* **7**, 186–191.
 62. Joo, M., and Makino, S. (1995) The effect of two closely inserted transcription consensus sequences on coronavirus transcription. *J. Virol.* **69**, 272–280.

63. Makino, S., Joo, M., and Makino, J. K. (1991) A system for study of coronavirus mRNA synthesis: A regulated, expressed subgenomic defective interfering RNA results from intergenic site insertion. *J. Virol.* **65**, 6031–6041.
64. Carpenter, C. D., Oh, J. W., Zhang, C., and Simon, A. E. (1995) Involvement of a stem-loop structure in the location of junction sites in viral RNA recombination. *J. Mol. Biol.* **245**, 608–622.
65. White, A. K., and Morris, T. J. (1995) RNA determinants of junction site selection in RNA virus recombinants and defective interfering RNAs. *RNA* **1**, 1029–1040.
66. Nagy, P. D., and Bujarski, J. J. (1996) Homologous RNA recombination in brome mosaic virus: AU-rich sequences decrease the accuracy of crossovers. *J. Virol.* **70**, 415–426.
67. Simon, A. E., and Bujarski, J. J. (1994) RNA–RNA recombination and evolution in virus-infected plants. *Annu. Rev. Phytopathol.* **32**, 337–362.
68. Zhang, X., Liao, C. L., and Lai, M. M. C. (1994) Coronavirus leader RNA regulates and initiates subgenomic mRNA transcription both *in trans* and *in cis*. *J. Virol.* **68**, 4738–4736.
69. Liao, C. L., and Lai, M. M. C. (1992) RNA recombination in a coronavirus: Recombination between viral genomic RNA and transfected RNA fragments. *J. Virol.* **66**, 6117–6124.
70. Joo, M., Banerjee, S., and Makino, S. (1996) Replication of murine coronavirus defective interfering RNA from negative-strand transcripts. *J. Virol.* **70**, 5769–5776.
71. Koetzner, C. A., Parker, M. M., Ricard, C. S., Sturman, L. S., and Masters, P. S. (1992) Repair and mutagenesis of the genome of a deletion mutant of the coronavirus mouse hepatitis virus by targeted RNA recombination. *J. Virol.* **66**, 1841–1848.
72. Peng, D., Koetzner, C. A., and Masters, P. S. (1995) Analysis of second-site revertants of a murine coronavirus and nucleocapsid protein deletion mutant and construction of nucleocapsid protein mutants by targeted RNA recombination. *J. Virol.* **69**, 3449–3457.
73. van der Most, R. G., Heijnen, L., Spaan, W. J. M., and de Groot, R. J. (1991) Homologous RNA recombination allows efficient introduction of site-specific mutations into the genome of coronavirus MHV-A59 via synthetic co-replicating RNAs. *Nucleic Acids Res.* **20**, 3375–3381.
74. Peng, D., Koetzner, C. A., McMahon, T., Zhu, Y., and Masters, P. S. (1995) Construction of murine coronavirus mutants containing interspecies chimeric nucleocapsid proteins. *J. Virol.* **69**, 5475–5484.
75. Zhang, L., Homberger, F., Spaan, W., and Luytjes, W. (1997) Recombinant genomic RNA of coronavirus MHV-A59 after co-replication with a DI RNA containing the MHV-RI spike gene. *Virology* **230**, 93–102.
76. Tahara, S. M., Dietlin, T. A., Bergmann, C. C., Nelson, G. W., Kyuwa, S., Anthony, R. P., and Stohlman, S. A. (1994) Coronavirus translational regulation: Leader affects mRNA efficiency. *Virology* **202**, 621–630.
77. Snijder, E. J., den Boon, J. A., Horzinek, M. C., and Spaan, W. J. M. (1991) Characterization of defective interfering RNAs of Berne virus. *J. Gen. Virol.* **72**, 1635–1643.
78. van Dinten, L. C., den Boon, J. A., Wassenaar, A. L. M., Spaan, W. J. M., and Snijder, E. J. (1997) An infectious arterivirus cDNA clone: Identification of a replicase point mutation that abolishes discontinuous mRNA transcription. *Proc. Natl. Acad. Sci. USA* **94**, 991–996.
79. Bos, E. C., Luytjes, W., van der Meulen, H. V., Koerten, H. K., and Spaan, W. J. M. (1996) The production of recombinant infectious DI particles of a murine coronavirus in the absence of helper virus. *Virology* **218**, 52–60.