



ELSEVIER

Contents lists available at ScienceDirect

## Data in Brief

journal homepage: [www.elsevier.com/locate/dib](http://www.elsevier.com/locate/dib)

## Data Article

## Data on ion-exchange membrane fouling by humic acid during electro dialysis

Bram De Jaegher<sup>a,b,c,d,\*</sup>, Eneko Larumbe<sup>c</sup>, Wim De Schepper<sup>c</sup>, Arne Verliefde<sup>b</sup>, Ingmar Nopens<sup>a</sup><sup>a</sup> BIOMATH, Department of Data Analysis and Mathematical Modelling, Ghent University, Coupure links 653, 9000 Ghent, Belgium<sup>b</sup> PalmT, Department of Green Chemistry and Technology, Ghent University, Coupure links 653, 9000 Ghent, Belgium<sup>c</sup> Flemish Institute for Technological Research (VITO), Boeretang 200, 2400 Mol, Belgium<sup>d</sup> CAPTURE, Centre for Advanced Process Technology for Urban Resource recovery, Coupure links 653, 9000 Ghent, Belgium

## ARTICLE INFO

## Article history:

Received 28 April 2020

Revised 18 May 2020

Accepted 18 May 2020

Available online 25 May 2020

## Keywords:

Electrodialysis  
colloidal fouling  
humic acid  
ion-exchange membranes  
process settings  
bio-based

## ABSTRACT

This data paper aims to provide data on the effect of the process settings on the fouling of an electro dialysis pilot installation treating a sodium chloride solution (0.1 M and 0.2 M) in the presence of humic acid (1 g/L). This data was used by “Colloidal fouling in electro dialysis: a neural differential equations model” [1] to construct a predictive model and provides interpretive insights into this dataset. 22 electro dialysis fouling experiments were performed where the electrical resistance over the electro dialysis stack was monitored while varying the crossflow velocity (2.0 cm/s - 3.5 cm/s) in the compartments, the current applied (1.41 A - 1.91 A) to the stack and the salt concentration in the incoming stream. The active cycle was maintained for a maximum of 1.5 h after which the polarity was reversed to remove the fouling layer. Additional data is gathered such as the temperature, pH, flow rate, conductivity, pressure in the different compartments of the electro dialysis stack. The data is processed to remove the effect of temperature fluctuations and some filtering is performed. To maximise the reuse potential of this dataset, both raw and processed data are provided along with a detailed description of the pilot installation and sensor locations. The data generated can be useful for researchers and industry

\* Corresponding author.

E-mail address: [Bram.DeJaegher@UGent.be](mailto:Bram.DeJaegher@UGent.be) (B. De Jaegher).

working on electro dialysis fouling and the modelling thereof. The availability of conductivity and pH in all compartments is useful to investigate secondary effects of humic acid fouling such as the eventual decrease in membrane permselectivity or water splitting effects introduced by the fouling layer.

© 2020 Published by Elsevier Inc.

This is an open access article under the CC BY-NC-ND license. (<http://creativecommons.org/licenses/by-nc-nd/4.0/>)

---

## Specifications table

---

Subject	Filtration and separation
Specific subject area	Electrodialysis fouling
Type of data	Tables Code
How data were acquired	The data consist of time series of an electro dialysis pilot installation that processes a sodium chloride solution with humic acid and is subject to fouling. Each of the experiments is performed at a different crossflow velocity, applied current and the salt concentration in the fouling solution, following an experimental design. Different inline sensors monitor the state of the ED pilot; <ul style="list-style-type: none"> <li>• Electric potential (M 3000 - Delta elektronika, the Netherlands)</li> <li>• Conductivity &amp; temperature (Indumax CLS50D - Endress + Hauser, USA)</li> <li>• Flow rate (Promag 55S DN15 - Endress + Hauser, USA)</li> <li>• pH (Orbisint CPS11D - Endress + Hauser, USA)</li> <li>• Pressure (Cerabar MPMC51 - Endress + Hauser, USA)</li> </ul> The data acquisition and control is handled by Mefias®, a LabVIEW-based control software (VITO, Belgium).
Data format	Raw Filtered
Parameters for data collection	Ambient temperature (measured), Data acquired with a sampling period of 15 seconds for all sensors.
Data source location	Flemish institution of technological research (VITO), Mol, Belgium
Data accessibility	Repository name: A dataset on ion-exchange membrane fouling by humic acid during electro dialysis Data identification number: 10.5281/zenodo.3551928 Direct URL to data: <a href="http://doi.org/10.5281/zenodo.3551928">http://doi.org/10.5281/zenodo.3551928</a> The code used to process and analyse this dataset is published on Github: <a href="https://github.com/Beramos/Data-on-ion-exchange-membrane-fouling-by-humic-acid-during-electrodialysis">https://github.com/Beramos/Data-on-ion-exchange-membrane-fouling-by-humic-acid-during-electrodialysis</a>
Related research article	Bram De Jaegher, Wim De Schepper, Arne Verliefe, Ingmar Nopens, Colloidal fouling in electro dialysis: a neural differential equations model, Desalination, In Press

---

## Value of the data

- Ion-exchange membrane fouling is still an important hurdle to overcome when processing bio-based process streams through electro dialysis. Previous research showed that the fouling rate strongly depends on the process settings [2]. This dataset enables the quantification of these effects.
- Researchers and industry aiming to improve the fouling resistance of electro dialysis can make use of this dataset to explore the effect of the process settings on the fouling rate during electro dialysis. Furthermore, researchers aiming to develop mathematical models for fouling prediction can make use of this data.
- The availability of conductivity and pH measurements before and after all compartments can be used to investigate the secondary effects of humic acid fouling such as the decrease in membrane permselectivity or water splitting effects introduced by the fouling layer.

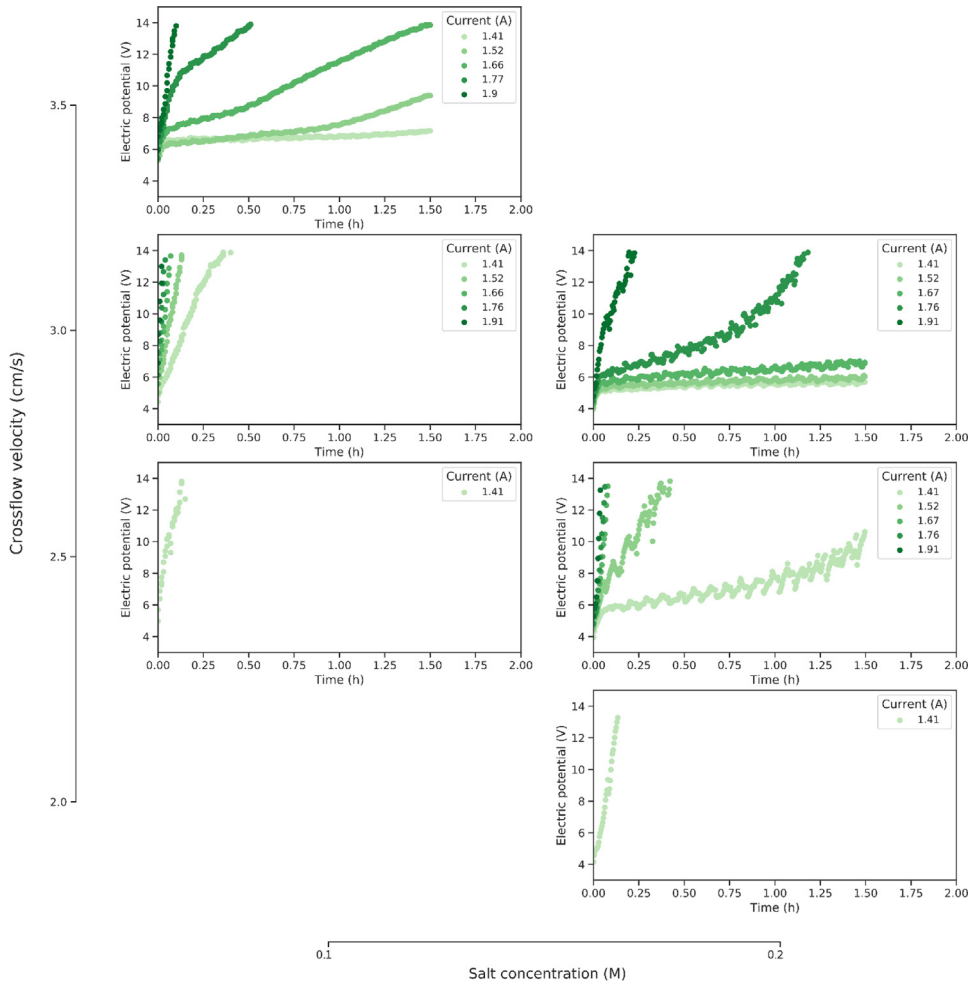
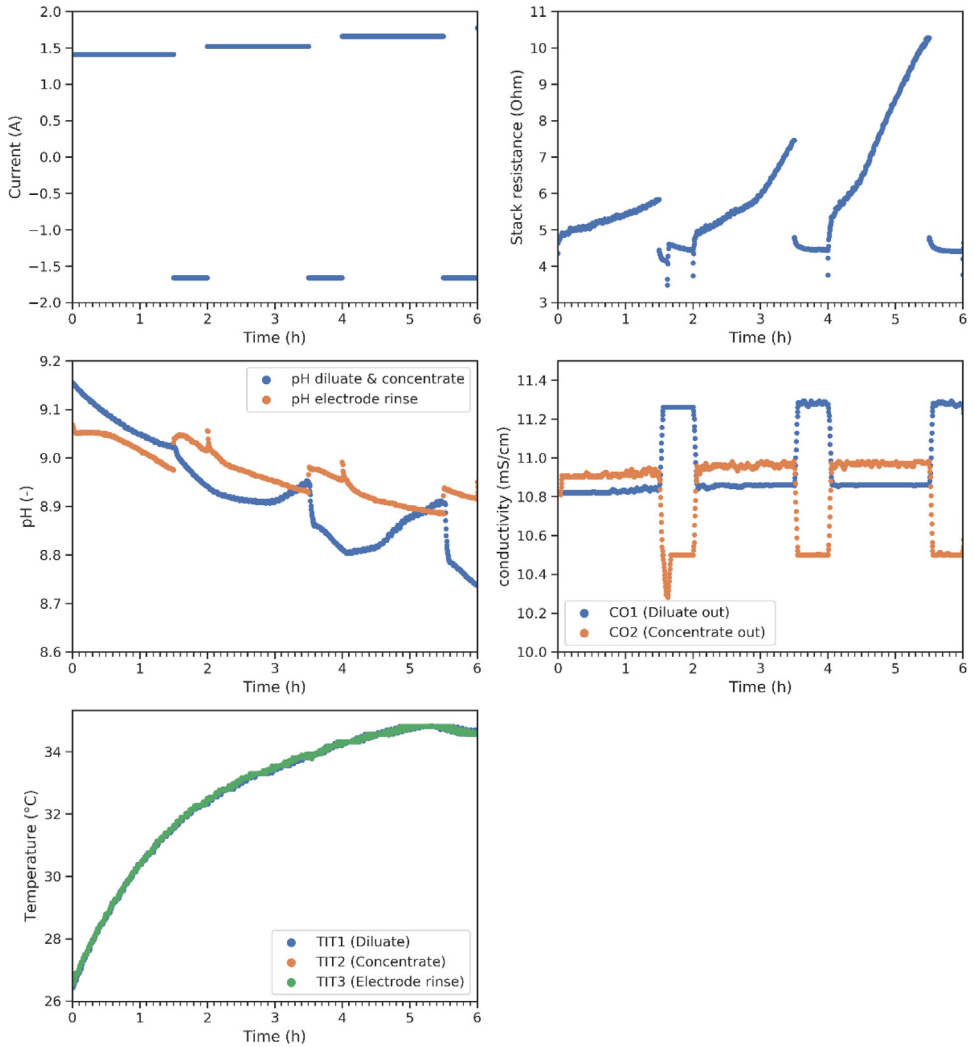

**Fig. 1.** A graphical summary of the performed experiments. The stack resistance in function of time for different currents (colour). The subfigures indicate different levels of crossflow velocity (vertical direction) and salt concentration (horizontal direction).

- This data is collected with the use for model training, calibration and validation in mind and provides more consistency, reproducibility and more measured quantities than previous work [2].

## 1. Data Description

The data consists of time series of different sensors throughout an electro dialysis pilot installation that processes a salt solution in the presence of humic acid. Humic acid fouling is described in a set of 22 experiments, performed under varying process settings as indicated by Fig. 4. Fig. 1 shows the evolution of the stack resistance for all experimental conditions. The y-axis depicts the stack resistance and the x-axis the time. The rows represent the different crossflow velocities tested and the columns the salt concentration. Next to this, a lot of additional sensor data is collected. A subset of the data is illustrated in Fig. 2 where three reversal cycles are dis-



**Fig. 2.** A subset of the sensor data on the applied current (a), the stack resistance (b), the pH (c), the conductivity (d) and the temperature (e) acquired by the various sensors during experimentation.

played at an increasing current. The alternation of the active and cleaning cycles is shown in Fig. 2a where the applied current is visualised in time. Next to the stack resistance (derived from the stack potential and applied current (Fig. 2a), there is data on the pH of the feed streams and the electrolyte rinsing solution (Fig. 2c). The conductivity is also monitored at 5 locations, two of which are visualised in Fig. 2d. Lastly, the temperature of the different circuits is monitored at 3 different locations (Fig. 2e). The data consists of both raw data and the processed data after temperature compensation (Eqs. 1-3), filtering (Eq. 4) and resampling. All data is available on a data repository on Zenodo and the code to reproduce the figures in this paper from the dataset is published on Github.

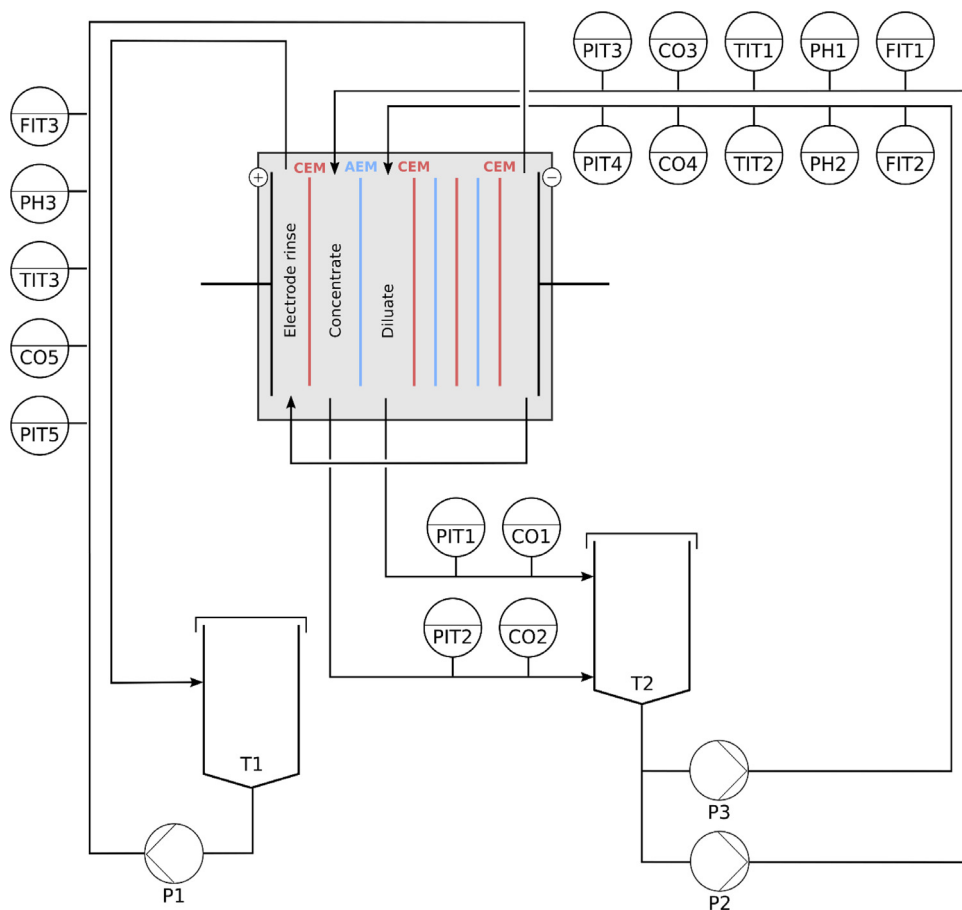

Fig. 3. Piping and Instrumentation diagram of the ED pilot used in this study.

## 2. Experimental design, materials and methods

### 2.1. Electrodialysis pilot installation

An automated ED pilot installation (VITO, Belgium) is used to generate the data in a series of electrodialysis fouling experiments. The ED installation consists of three circulation loops separating the concentrate, diluate and electrode rinsing solutions. The diluate and concentrate compartments are connected to the same storage tank to ensure a constant salt concentration. The electrolyte rinsing circuit is fed by a 0.1M solution of  $\text{Na}_2\text{SO}_4$  in a separate tank and pumped to the anode and cathode compartments in series. The concentrate, diluate and electrolyte rinsing circuit are driven by three separate pumps (GM-V IWAKI USA - PID controlled). In the pilot, the temperature, pH, flow rate, conductivity, pressure and electric potential are measured at several locations in the pilot installation, a detailed overview of the sensor locations is shown in Fig. 3. An overview of the different sensors along with the manufacturers' information is provided in Table 1. The data acquisition and control is handled by Mefias®, a LabVIEW-based control software (VITO, Belgium). An FT-ED(R)-100-4 (ED100, FuMA-Tech, Germany) ED stack with three cell pairs is built of alternating cation- and anion-exchange membranes, starting and ending with a cation-exchange membrane. The cation- and anion-exchange membranes used in this study are

**Table 1**

An overview of the sensors in the pilot installation along with information on the identifier in the P&ID, the manufacturer and the units of the measured signal.

Parameter	Identifiers	Manufacturer	Unit
Electric potential	EPx	M 3000 - Delta elektronika, the Netherlands	(V)
Conductivity	COx	Indumax CLS50D - Endress + Hauser, USA	(mS/cm)
Temperature	TITx	Indumax CLS50D - Endress + Hauser, USA	(°C)
pH	PHx	Orbisint CPS11D - Endress + Hauser, USA	(-)
Flowrate	FITx	Promag 55S DN15 - Endress + Hauser, USA	(l/h)
Pressure	PITx	Cerabar MPMC51 - Endress + Hauser, USA	(bar)

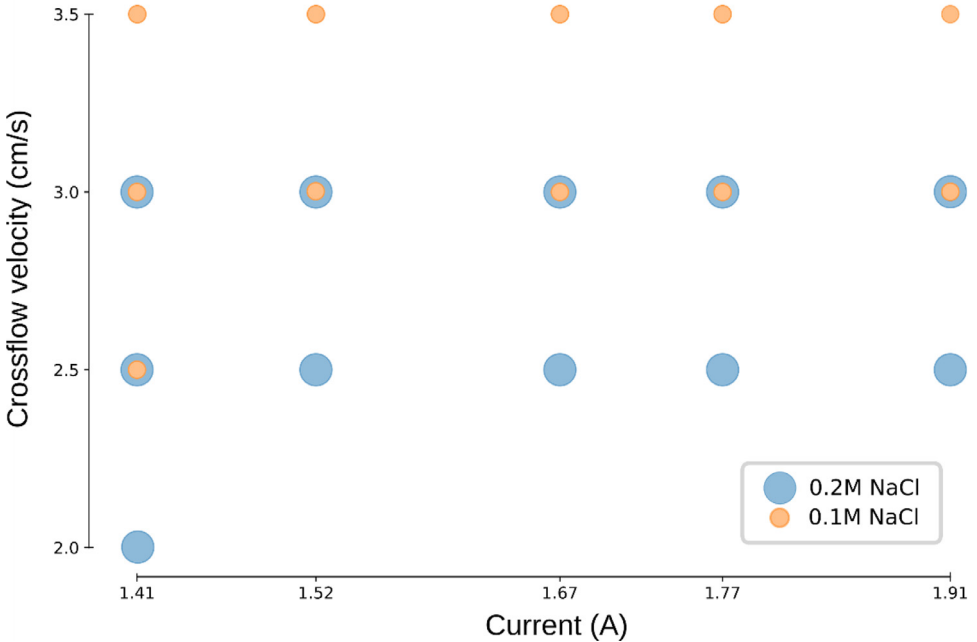

**Fig. 4.** Experimental design of the 22 experiments performed in this study. Each point represents an experiment and the three degrees of freedom are the crossflow velocity (y-axis), the current density applied (x-axis) and the concentration of NaCl added to the fouling solution (size and colour of the markers).

homogeneous PCA-SK and PCA-SA membranes (PCA GmbH, Germany), respectively, both with a surface area of 100cm<sup>2</sup>. The ED stack is powered by a power supply operated as a galvanostat (SM 3000 - Delta elektronika) [1].

## 2.2. Experimental Design

For every experiment the following procedure was followed, a NaCl solution is prepared at a certain concentration (Fig. 4 - colour) and humic acid is added to a concentration of 1 g/L. Next, the electro dialysis pilot installation is run at a certain crossflow velocity and current density (Fig. 4 - x/y axis). Following this procedure, 22 experiments were performed at a different crossflow velocity, applied current and the salt concentration in the fouling solution, according to the experimental design depicted in Fig. 4. The time series consists of the electrical resis-

tance of the stack as a measure of the fouling severity [2] complemented by the data from the above-mentioned inline sensors. Humic acid sodium salt (Sigma-Aldrich) is used as the fouling component in 1g/L solution.

### 2.3. Data-processing and filtering

The data sampling period for data-acquisition is 15 seconds for all sensors. Each of the experiments presented in Fig. 4. As time progresses the resistance of the stack increases and as the power supply is operated in a galvanostatic manner the potential applied to system increases. For some of the experimental conditions presented in Fig. 4 the fouling intensity was severe and the maximum potential of 15V was reached before 1.5h and are terminated early. Consequently, the length of the experiments varies from a few minutes to a maximum of 1.5h (360 data points). After termination or after 1.5h the polarity of the electrodes is inverted for 0.5h to clean the membranes and bring the system back to its original state. To remove the internal and external temperature effects on the stack resistance a non-linear temperature compensation is performed which takes into account the effect of temperature on water viscosity and ion diffusivity [3],

$$R_{20} = 0.889 \cdot 10^{A/B} R \quad (1)$$

with  $R_{20}$  the compensated resistance,  $R$  the measured resistance.  $A$  and  $B$  are temperature-dependent parameters and are computed as follows [3],

$$A = 1.37 (T - 20) + 8.36 \cdot 10^{-4} (T - 20)^2 \quad (2)$$

$$B = 109 + T \quad (3)$$

with  $T$  the temperature ( $^{\circ}\text{C}$ ). By applying this compensation, the effect of temperature fluctuations is eliminated. Filtering of the data was performed with a simple moving-average filter with a window size of 10 data points,

$$\bar{x}_j = \frac{1}{N} \sum_{i=0}^N x_{j-i} \quad (4)$$

Finally, the data is resampled to yield 20 time points spanning each experiment.

### Declaration of Competing Interest

The authors declare that they have no known competing financial interests or personal relationships which have, or could be perceived to have, influenced the work reported in this article.

### Acknowledgements

This work was supported by the Flemish institute for technological research (VITO).

### References

- [1] De Jaegher B., De Schepper W., Verliefe A., Nopens I. C., Colloidal fouling in electrodialysis: a neural differential equations model, Desalination, In Press.
- [2] E. Korngold, F. de Körösy, R. Rahav, M.F. Taboch, Fouling of anion-selective membranes in electrodialysis, Desalination 8 (2) (1970) 195–220 ISSN 00119164, doi:10.1016/S0011-9164(00)80230-1.
- [3] P. Atkins, J. de Paula, W.H. Freeman (Ed.), Physical Chemistry: Thermodynamics, Structure, and Change, 9780716787594, 2014 ISBN.