

CORRECTION

Correction to: *Mitochondrial Morphofunction in Mammalian Cells* by Bulthuis EP *et al.*
Antioxid. Redox Signal. 30: 2066-2109, 2019.
 DOI: 10.1089/ars.2018.7534.correx

IN THE JUNE 20, 2019 issue of *Antioxidants & Redox Signaling* (vol. 30, no. 18; 2066-2109) the article entitled “Mitochondrial Morphofunction in Mammalian Cells” by Bulthuis *et al.* requires correction.

Figure 1 contained an arrow pointing from right to left through the CII symbol, erroneously depicting CII as proton-pumping. The original Figure 1 is shown below:

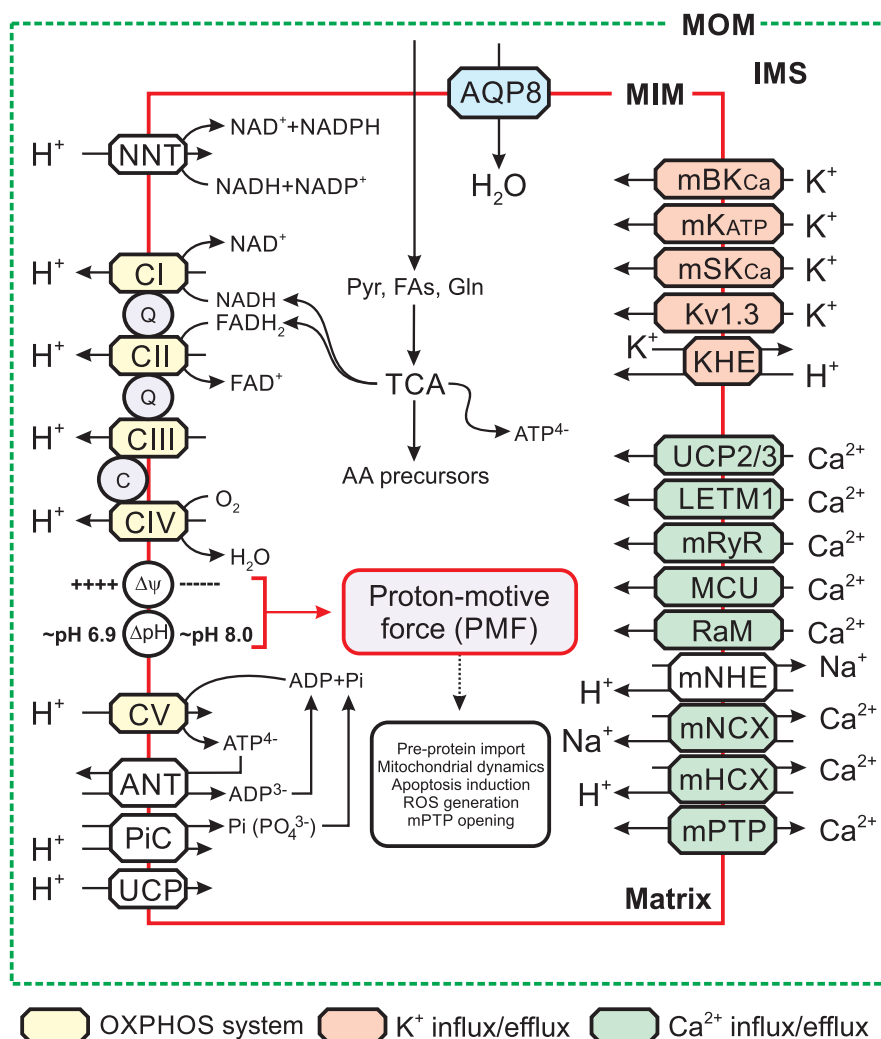
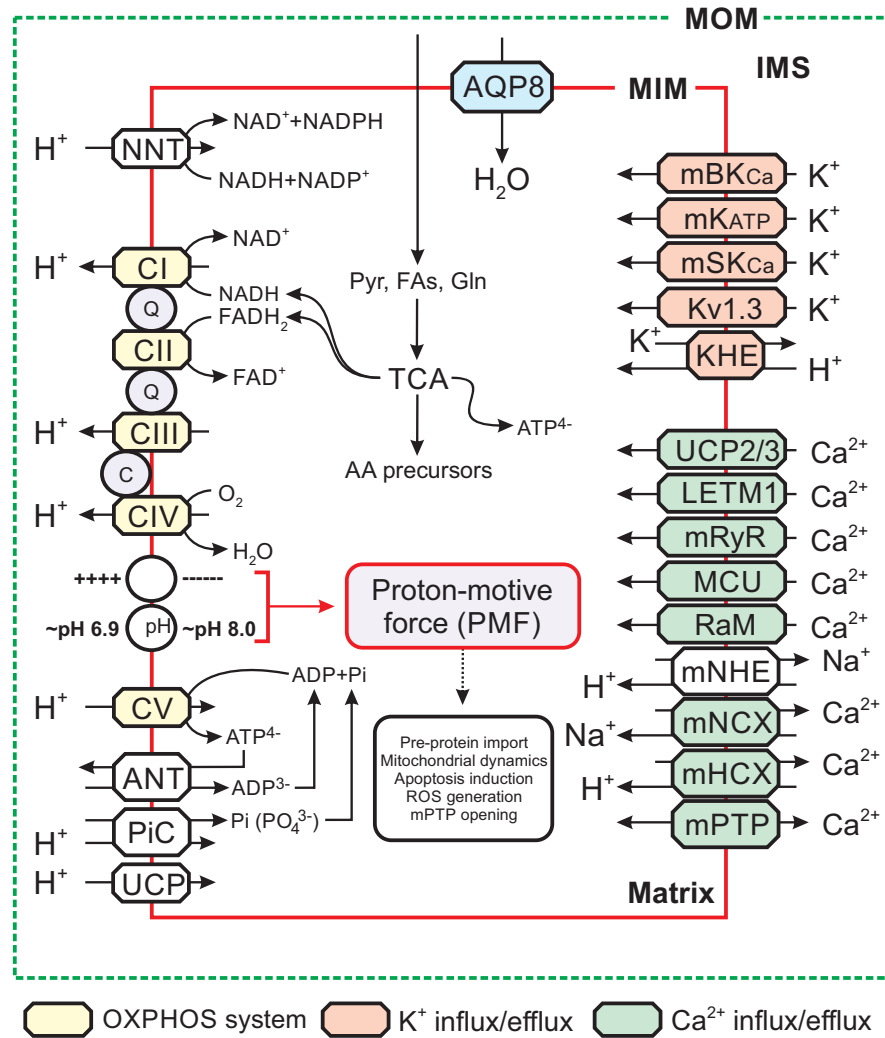

Figure 1 has been replaced with the correct image with the arrow removed:



The online version has been corrected to reflect this. The authors apologize for this error.