



Published in final edited form as:

*Comput Cardiol (2010)*. 2020 September ; 47: . doi:10.22489/cinc.2020.188.

## High-Capacity Cardiac Signal Acquisition System for Flexible, Simultaneous, Multidomain Acquisition

Brian Zenger<sup>1,2,3,4</sup>, Jake A Bergquist<sup>1,2,4</sup>, Wilson W Good<sup>1,2,4</sup>, Bruce Steadman<sup>2</sup>, Rob S MacLeod<sup>1,2,3,4</sup>

<sup>1</sup>Scientific Computing and Imaging Institute, SLC, USA

<sup>2</sup>Nora Eccles Cardiovascular Research and Training Institute, SLC, USA

<sup>3</sup>School of Medicine, University of Utah, SLC, USA

<sup>4</sup>Department of Biomedical Engineering, University of Utah, SLC, USA

### Abstract

Capturing cardiac electrical propagation or electrocardiographic images demands simultaneous, multidomain recordings of electrocardiographic signals with adequate spatial and temporal resolution. Available systems can be cost-prohibitive or lack the necessary flexibility to capture signals from the heart and torso. We have designed and constructed a system that leverages affordable commercial products (Intantech, CA, USA) to create a complete, cardiac signal acquisition system that includes a flexible front end, analog signal conditioning, and defibrillation protection. The design specifications for this project were to (1) record up to 1024 channels simultaneously at a minimum of 1 kHz, (2) capture signals within the range of  $\pm 30$  mV with a resolution of 1  $\mu$ V, and (3) provide a flexible interface for custom electrode inputs. We integrated the Intantech A/D conversion circuits to create a novel system, which meets all the required specifications. The system connects to a standard laptop computer under control of open-source software (Intantech). To test the system, we recorded electrograms from within the myocardium, on the heart surface, and on the body surface simultaneously from a porcine experimental preparation. Noise levels were comparable to both our existing, custom acquisition system and a commercial competitor. The cost per channel was \$32 USD, totaling \$33,800 USD for a complete system.

### 1. Introduction

Improving our understanding of cardiac electrical propagation and electrocardiographic imaging demands simultaneous multidomain signal recordings with high spatial and temporal resolution. [1–4] Electrical activation of the heart and the resulting bioelectric currents and electrical fields in the thorax are complex, dynamic events. Capturing these events with any degree of coverage requires hundreds of individual recording sites organized throughout the heart and torso. While past experience, especially of the normal heartbeat, may allow some efficiencies in spatial density or coverage, pathophysiology can take an

almost infinite number of forms so that detailed understanding requires detailed sampling. Therefore, especially in the research setting, there is a significant need for cardiac signal acquisition, or ‘mapping’ systems that can record a large number of signals simultaneously with a high temporal resolution. First, the terms ‘large’ and ‘high’ need to be defined in a specific context, along with the other specifications of a useful mapping system.

Several characteristics are typical of a contemporary cardiac electrocardiographic mapping systems. First, the inputs must be flexible enough to use with a wide variety of recording arrays, each of which samples a different region of the heart and thorax, resulting in a range of signal amplitudes from microvolts to millivolts.[5] Second, the system must employ carefully tuned analog signal filtering, amplifier gains, and flexible referencing, and also protect against defibrillation pulses that can arise during an experiment. Third, the system must convert analog electrical potentials to digital signals with high fidelity, minimal noise, and adequate sampling and time resolutions for subsequent processing and analysis. Finally, the system must display and store the resulting volumes of signal data in a manner that facilitates subsequent retrieval for transfer and postprocessing.

Meeting the small demand during the early phases of cardiac mapping research required custom systems, constructed by the researchers, and based on the limited capabilities of the time, often using the most advanced components available. [6–10] Such custom systems have improved in capacity to record from 256, 512, and up to 1024 channels simultaneously at up to 1kHz sampling frequency. Some of these custom systems are still in use today; [10] however, they are extremely large and difficult to repair, and their advancement is limited by hardware and software constraints. Recent commercial interest, especially driven by neuroscience research, has motivated important advances beyond these custom systems, including state-of-the-art miniaturization, improvements to stability, and increased capacity. [8, 11] However, these commercial systems tend to come at a high cost, with limitations such as input signal range and the inability to connect custom electrode configurations.

With these characteristics and current system limitations, we set out to design and build an inexpensive and flexible cardiac mapping system based on the core functionality of an available, state-of-the-art commercial system (Intantech, CA, USA). For comprehensive cardiac applications, we required that the system record signals from within the heart, on the heart surface, and on the torso surface, potentially simultaneously. To record these diverse and numerous signals, a mapping system must be able to (1) record up to 1024 channels simultaneously at a minimum of 1 kHz sampling rates, (2) record signals within the full range of cardiac potentials, up to  $\pm 30$  mV with a sensitivity of  $1 \mu\text{V}$ , and (3) provide a flexible interface to allow for custom electrode inputs.

## 2. Methods

### 2.1. System Design:

Our design is based on the commercial Intantech (CA, USA) acquisition system, which is a miniaturized system designed to sample and record neurological potentials in electrophysiology research applications.[11] These systems are extremely compact, relatively inexpensive, and consist of a biosignal acquisition chip, recording controller, and

an interface to a standard computer to control acquisition and to capture signals. The final two elements (panels D and E) in Figure 1 show the Intantech system in the context of our design.

Key elements of any acquisition system are the signal conditioning and the analog-to-digital (A/D) conversion. Intantech has packaged these steps into a single acquisition chip that contains the integrated components for A/D conversion, filtering, and sampling for 64 individual analog channels. The bandpass filters are adjustable, with variable upper and lower cutoff frequencies ranging between 100 Hz to 20 kHz and 0.1 Hz to 500 Hz, respectively. The A/D converters can sample between 1 kHz to 30 kHz and record input voltages between  $\pm 5$  mV at 16-bit resolution, which provides a dynamic range of 65,536 levels or 96 dB. In addition, auxiliary ADC inputs are available for interfacing with the chip directly. With systems that acquire many channels simultaneously, the next step is multiplexing the output of all the A/D converters into a single data stream and then capturing and storing this stream. The Intantech system controller supports up to 1024 channels simultaneously and relays this information via a USB interface to a separate standard computer, laptop, or desktop. For our system, we selected a standard Apple Mac Mini with a 3.2 GHz 6 core Intel i7 processor, 16 GB of DDR4 RAM, and a 256 GB SSD Hard Drive. Intantech provides an open-source recording software package for the computer that supports driving the acquisition, controlling the adjustable parameters of the acquisition chips, and visualizing up to 64 channels simultaneously. Once recorded, the files can be opened and processed using MATLAB specific file readers for any subsequent signal processing. We have developed an open-source toolkit, PFEIFER, for processing electrograms [12] to generate all the sample results shown here.

## 2.2. Modifications to the Intantech system

The Intantech system is highly miniaturized and efficient but was designed to record neural signals, which are much smaller in amplitude and have a different frequency spectra from cardiac electrograms and ECGs. Therefore, significant modifications were needed to adapt this system for cardiac mapping. To meet cardiac needs, we designed an additional subsystem that would (1) connect with custom electrodes used in the cardiac mapping, (2) lower the voltage range of cardiac signals within the range of the Intantech system, (3) provide AC-coupling suitable for cardiac applications, and (4) protect against the possibility of defibrillation during recording.

To achieve these goals, we developed a signal processing subsystem that incorporated the Intantech acquisition chips and augmented them with the features necessary for cardiac applications. Figure 2 shows the block diagram of an individual channel and front-end signal processing. We implemented a combination of diodes ( $\pm 5$  V) and electronic relays at each channel that can be deactivated in the case of defibrillation, thus decoupling the sensitive electronics from the electrodes. The analog signals then pass through a high pass filter with a cutoff frequency of 0.03 Hz. The signals are gain adjusted and buffered by stepping up by 10X, AC-coupling, and then attenuating by 0.015-X, totaling an attenuation of 0.15-X. This attenuation and coupling allowed a functional recording range of input signals between  $\pm 33$  mV to be safely lowered to the Intantech input range of  $\pm 5$  mV. Grounding and reference

ports for Wilson's central terminal were also added to correctly reference input signals to the Intantech system.

To connect with our highly variable custom electrode configurations, we also developed a customizable 'front-porch' system. This system was based on a previous design that allowed for swapping of 'faceplates' with a wide variety of high-density input connectors, each assembled for a customized recording array or arrays. The completed equipment was mounted on a rolling cart for easy movement and transport. The second two panels of Figure 1 show the elements of the resulting system. The overall dimensions of the new system were approximately 25% of those of our previous mapping hardware.

### 3. Results

#### 3.1. Recorded Signals

We tested our novel cardiac mapping system by recording intramyocardial, epicardial, and torso cardiac signals of an experiment model described previously.[5] The example experimental recording in figure 3 shows 530 individual electrograms from all three domains. The peak-to-peak amplitude ranges were 25 mV, 18 mV, and 1 mV, for the intramural, epicardial, and torso domains, respectively.

#### 3.2. Assembly and Cost

The signal processing subsystem and integration of the Intantech acquisition chips were manufactured and assembled using standard professional printed circuit board equipment and surface mount techniques. The total cost of the system was \$33,000 USD which was \$32 USD per channel.

### 4. Discussion

We designed and constructed a flexible, inexpensive, cardiac mapping system that can record up to 1024 channels of cardiac potentials at over 1 kHz. The system is based on the Intantech neural recording system, which provides 16-bit resolution. To adapt this system to cardiac electrograms, we designed a signal processing subsystem that includes high pass filtering, signal attenuation, AC coupling, and defibrillation protection. The system attenuates cardiac potentials to within the recording range of the Intantech system ( $\pm 5$  mV). Finally, we incorporated a 'front-porch' system to interface between the signal preprocessing system and our custom electrode arrays.

### Acknowledgments

Support for this research came from the NIH NIGMS Center for Integrative Biomedical Computing ([www.sci.utah.edu/cibc](http://www.sci.utah.edu/cibc)), NIH NIGMS grant no. P41GM103545, the Nora Eccles Treadwell Foundation for Cardiovascular Research, and a University of Utah Vice President for Research Equipment Grant.

### References

- [1]. Aras K, Burton B, Swenson D, MacLeod R. Sensitivity of epicardial electrical markers to acute ischemia detection. *Journal of Electrocardiology* 2014;47(6):836–841. [PubMed: 25242529]

- [2]. Aras K, Burton B, Swenson D, MacLeod R. Spatial organization of acute myocardial ischemia. *Journal of Electrocardiology* 2016;49(3):323–336. [PubMed: 26947437]
- [3]. Tate JD. Validating Simulation Pipelines With Potential Recordings. Ph.D. thesis, University of Utah, 2018.
- [4]. Trew ML, Engelman ZJ, Caldwell BJ, Lever NA, LeGrice IJ, Smaill BH. Cardiac intramural electrical mapping reveals focal delays but no conduction velocity slowing in the peri-infarct region. *American Journal of Physiology Heart and Circulatory Physiology* 2019;317(4):H743–H753. ISSN 0363–6135. [PubMed: 31419152]
- [5]. Zenger B, Good WW, Bergquist JA, Burton BM, Tate JD, Berkenbile L, Sharma V, MacLeod RS. Novel experimental model for studying the spatiotemporal electrical signature of acute myocardial ischemia: a translational platform. *Physiological Measurement* 2020;41(1):15002. ISSN 1361–6579.
- [6]. Horá B, Eifler W, Gerwitz H, Helppi R, Macaulay P, Sherwood J, Smith E, Tiberghien J, Rautaharju P. An automated system for body-surface potential mapping. In Ostrow H, Ripley K (eds.), *IEEE Computers in Cardiology*. IEEE Computer Society, 1977; 399–407.
- [7]. Wolf P, Rollins D, Simpson E, Smith W, Ideker R. A 528 channel system for the acquisition and display of defibrillation and electrocardiographic potentials. In *Proceedings of Computers in Cardiology Conference*. 1993; 125–128.
- [8]. MettingVanRijn A, Peper A, Grimbergen C. Amplifiers for bioelectric events: a design with a minimal number of parts. *Medical and Biological Engineering and Computing* 1994; 32(3):305–310. [PubMed: 7934255]
- [9]. Martel S, Lafontaine S, Bullivant D, Hunter I, Hunter P. A hardware object-oriented cardiac mapping system. In *Proceedings of the IEEE Engineering in Medicine and Biology Society 17th Annual International Conference*. 1995; 1647.
- [10]. Ershler P, Steadman B, Moore K, Lux R. Systems for measuring and tracking electrophysiologic distributions. *Proceedings of the IEEE Engineering in Medicine and Biology Society 20th Annual International Conference* 1998; 17(1):56–61.
- [11]. Du J, Blanche T, Harrison R, Lester H, Masmanidis S. Multiplexed, high density electrophysiology with nanofabricated neural probes. *PLoS One* 2011;6(10):e26204. [PubMed: 22022568]
- [12]. Rodenhauer A, Good WW, Zenger B, Tate J, Aras K, Burton B, MacLeod RS. Pfeifer: Preprocessing framework for electrograms intermittently fiducialized from experimental recordings. *The Journal of Open Source Software* 2018; 3:472. [PubMed: 30259008]

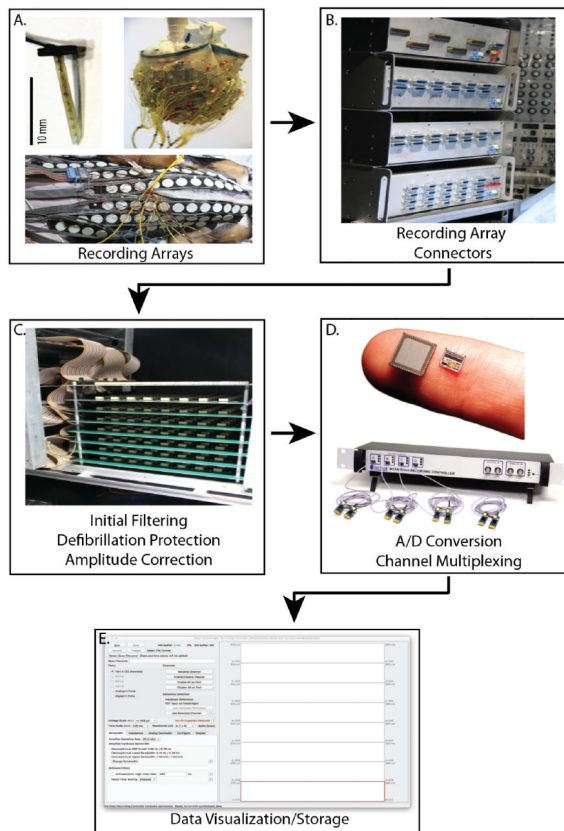

a

**Figure 1.**

Necessary components of a cardiac mapping system. A. Cardiac potentials are recorded from multiple domains using custom electrode arrays. B. A flexible 'front porch' system provides connections. C. An initial filtering, defibrillation protection, and signal attenuation condition the signals. D. Signals are then converted to a digital form, multiplexed into a single data stream, and transferred to a computer. E. Computer visualization and storage.

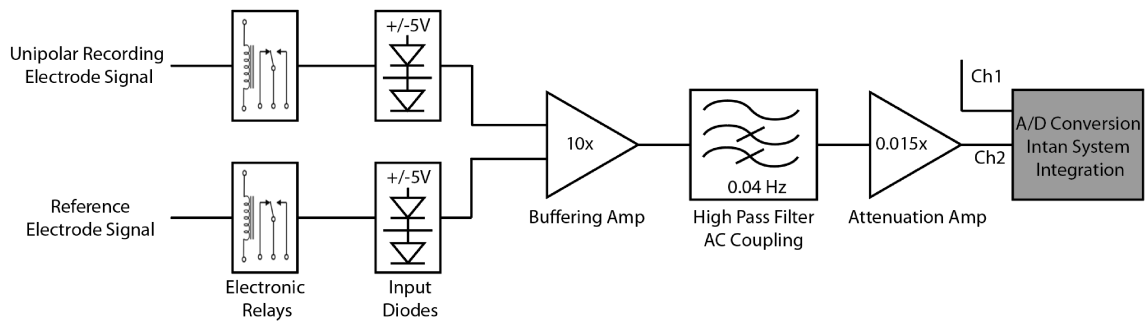

**Figure 2.** Block diagram of the designed front-end system including defibrillation protection (relays and diodes), filtering (high pass filter), and signal attenuation (amplifiers).

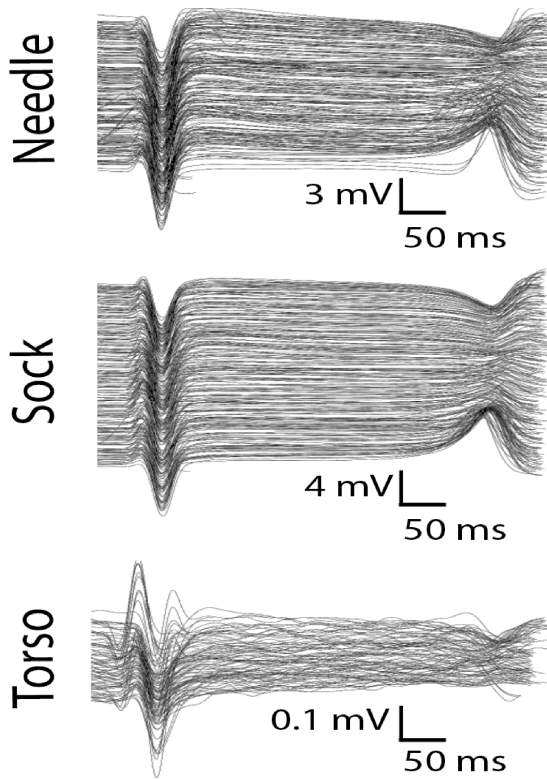

**Figure 3.** Example simultaneous recordings from three measurement domains: intramyocardial, epicardial, and the torso surface. A total of 530 channels are recorded from 204 needle, 233 sock, and 93 torso electrodes.