

CLINICAL REPORT

A novel essential splice site variant in *SPTB* in a large hereditary spherocytosis family

Taina T. Nieminen¹ | Sandya Liyanarachchi¹ | Daniel F. Comiskey Jr.¹ | Yanqiang Wang¹ | Wei Li¹ | Isabella V. Hendrickson¹ | Pamela Brock² | Albert de la Chapelle¹ | Huiling He¹ 

¹Department of Cancer Biology and Genetics, The Ohio State University, Columbus, Ohio, USA

²Department of Internal Medicine, The Ohio State University Comprehensive Cancer Center, The Ohio State University, Columbus, Ohio, USA

Correspondence

Huiling He, Department of Cancer Biology and Genetics, the Ohio State University, 460 W. 12th Avenue, Columbus, OH 43210, USA.
Email: huiling.he@osumc.edu

Funding information

This work was supported by National Cancer Institute Grants P30CA16058 and P01CA124570, and by Jane & Aatos Erkkö Foundation and Päivikki and Sakari Sohlberg Foundation.

Abstract

Background: We studied a large family with 22 individuals affected with autosomal dominant hereditary spherocytosis (HS).

Methods: Genome-wide linkage, whole-genome sequencing (WGS), Sanger sequencing, RT-PCR, and ToPO TA cloning analyses were performed.

Results: We revealed a heterozygous G>A transition in the 14q23 locus, at position +1 of the intron 8 donor splice site of the spectrin beta, erythrocytic (*SPTB*) gene. This splice variant (*SPTB* c.1064+1G>A) was confirmed by Sanger sequencing and showed complete co-segregation with HS in the family. Further RT-PCR reactions and sequencing analysis indicated that the variant leads to the exclusion of exon 8 and subsequent frameshift in exon 9 and a premature stop codon in *SPTB*. Translation of the altered allele would lead to a truncation with a loss of all spectrin repeat domains in *SPTB* protein.

Conclusion: This variant is novel and has not been found in any databases. We propose that this splice variant explains the spherocytosis phenotype observed in this large family.

KEYWORDS

DNA variant, hereditary spherocytosis, splicing, *SPTB*

Among the most common congenital diseases in humans are the different types of red blood cell malformations. In North America and Northern Europe, the most common inherited red blood cell disorder is hereditary spherocytosis (HS). Approximately 1:2000 individuals of Northern European ancestry are diagnosed with HS every year in the United States (Da Costa et al., 2013). However, given that spherocytosis symptoms are sometimes mild, the incidence is likely

underestimated (Da Costa et al., 2013). The most common symptoms of spherocytosis include anemia, splenomegaly, jaundice, and, in severe forms, iron overload and gallstones (Delaunay, 2007).

Red blood cells are the only human cell type without nuclei, naturally lacking DNA. The red blood cell membranes consist of approximately 20 major proteins and 850 minor ones (Pesciotta et al., 2012). These proteins are scattered in

Dr. Albert de la Chapelle passed away before publication.

This is an open access article under the terms of the Creative Commons Attribution-NonCommercial-NoDerivs License, which permits use and distribution in any medium, provided the original work is properly cited, the use is non-commercial and no modifications or adaptations are made.

© 2021 The Authors. *Molecular Genetics & Genomic Medicine* published by Wiley Periodicals LLC.

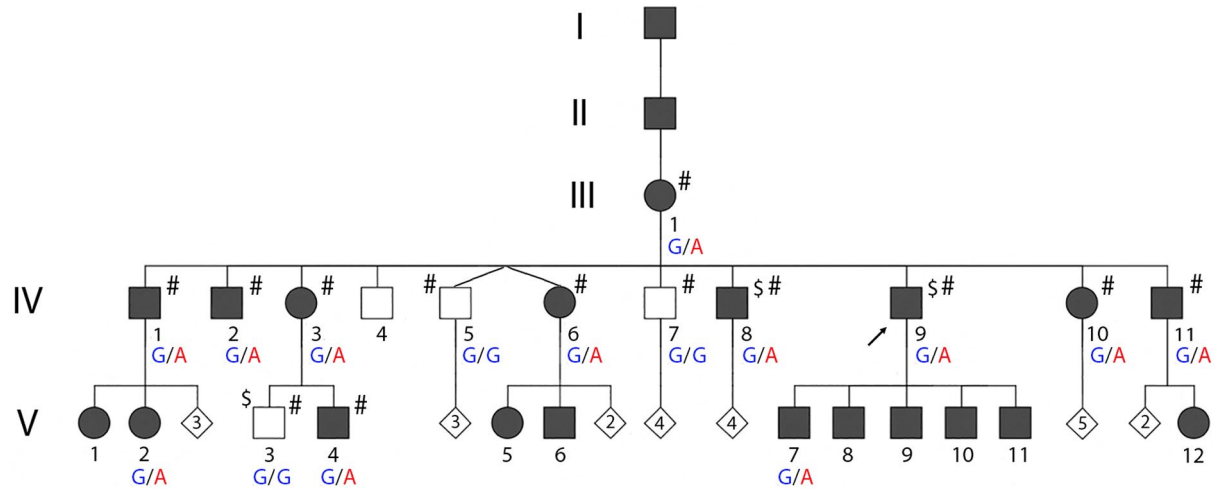

FIGURE 1 Pedigree of the hereditary spherocytosis (HS) family. Males are indicated by squares and females are indicated by circles. Generations are labeled using Roman numerals (I, II, III, etc). Solid symbols, affected. The index case is marked by an arrow. \$ indicates those individuals whose DNA was studied by WGS and # indicates those studied by linkage analysis. G/G, wild type; G/A, heterozygous variant.

Individual	Gender	Age at spherocytosis diagnose	Age at Splenectomy	Blood transfusion at birth	The c.1064+1G>A variant
III.1	Female	Unknown	17 or 18	Unknown	Yes
IV.1	Male	Birth	19 or 20	Unknown	Yes
IV.2 ^a	Male	Birth	Unknown	Unknown	Yes
IV.3	Female	Birth	19	Unknown	Yes
IV.6	Female	Birth	16	Yes	Yes
IV.8	Male	Birth	5	Yes	Yes
IV.9	Male	Birth	24	Yes	Yes
IV.10	Female	Birth	17 or 18	Yes	Yes
IV.11	Male	Birth	30 s	Yes	Yes
V.2	Female	Birth	7	Unknown	Yes
V.4	Male	Birth	14	Yes	Yes
V.7	Male	Birth	12	Unknown	Yes
IV.5	Male	Unaffected	N/A	N/A	No
IV.7	Male	Unaffected	N/A	N/A	No
V.3	Male	Unaffected	N/A	N/A	No

Abbreviations: N/A, not applicable.

^a Reported to have neurologic issues (cerebral palsy) from brain damage that occurred in newborn period from spherocytosis crisis.

TABLE 1 Clinical characteristics of investigated family members.

at least three separate red blood cell membrane-penetrating complexes: unbound band 3, ankyrin complex, and the actin junctional complex (Lux, 2016). The unbound band 3 complex associates with the ankyrin complex via glycoprotein A. The ankyrin complex is anchored to α - and β -spectrin proteins (Lux, 2016). Disruption of any major protein in these complexes, such as those caused by germline variants in the associated genes, will result in defects in the red blood cell membrane and lead to diseases of the red blood cells (Gallagher, 2013). In HS patients, pathogenic variants

have been reported in five genes, leading to five different types of the disease. HS type 1 is caused by mutations in the ankyrin1 (*ANK1*) gene. HS type 2 and type 3 are associated with variants in the spectrin beta, erythrocytic (*SPTB*, OMIM accession number 182870), and spectrin alpha, erythrocytic 1 (*SPTA1*) genes, respectively. HS type 4 is caused by mutations in the solute carrier family 4 member 1 (*SLC4A1*) gene and type 5 is caused by mutations in the erythrocyte membrane protein band 4.2 (*EPB42*) gene (Andolfo et al.,).

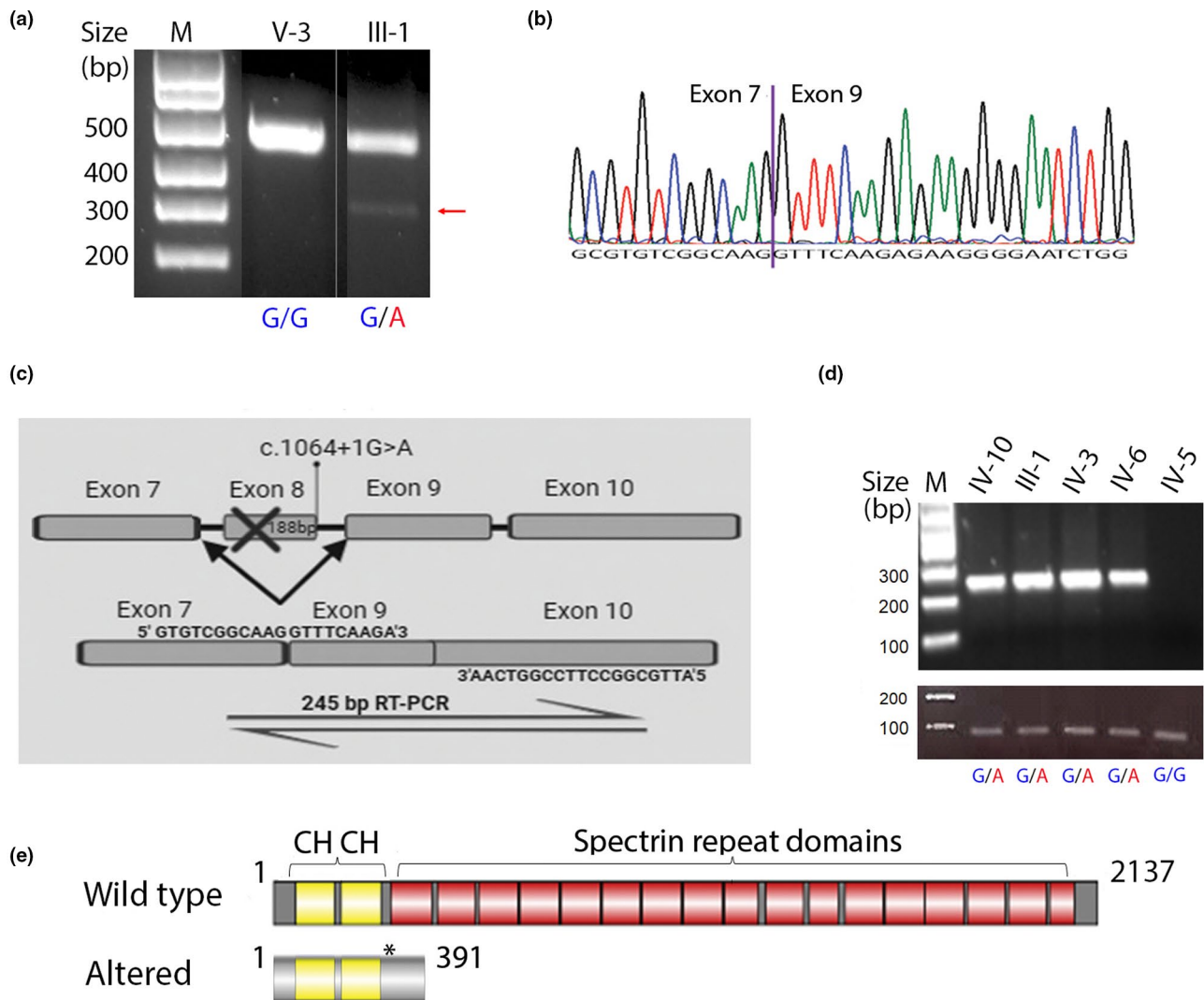

FIGURE 2 Analysis of the c.1064+1G>A variant in the *SPTB* gene (NM_001024858.4). (a) RT-PCR analysis of aberrant splicing using the forward primer in *SPTB* exon 7 and the reverse primer in exon 9. Total RNA from lymphoblastoid cell lines of four affected members and one unaffected family member was analyzed; two samples are shown in the gel picture (IV-5, unaffected; III-1, HS affected). M, molecular marker. The extra spliced product in sample III-1 is labeled by an arrow. (b) Sanger sequencing chromatogram of the aberrant spliced *SPTB* product in individual III-1. The junction of exons 7 and 9 is marked by a vertical line. (c) Diagram of the exon 8 skipping in *SPTB* showing the forward primer spanning the junction site of exons 7 and 9 and a reverse primer partly in exon 10 for detecting exon 8 skipping. (d) RT-PCR analysis of aberrant splicing using the unique primer set as shown in (c) with RNA samples from five family members (four affected and one unaffected). M, molecular marker. (e) Diagram of the *SPTB* wild-type protein structure and the truncated *SPTB* caused by the altered allele. CH, Calponin homology domain.

We report a large family with 22 individuals affected with HS demonstrating autosomal dominant inheritance (Figure 1). The family is of Caucasian ancestry and its members reside mainly in the *Midwest* of the United States. The typical clinical features in affected family members include anemia and splenomegaly. Almost all affected individuals in the family had jaundice within the first 24–48 h after birth. They often have developed severe anemia later in the newborn period. The clinical characteristics of the investigated family members are provided in Table 1. In addition, 12 individuals in the same family were diagnosed with non-medullary thyroid cancer (NMTC). There are eight individuals with both NMTC and

HS. This family was included in our previous genomic analysis of NMTC families (Wang et al., 2019). As is suggested by the data in the pedigree, HS and NMTC are genetically different and presumably unrelated (Wang et al., 2019). This was confirmed by a linkage analysis in which no common peak was shared between HS and NMTC. In this report, we focus only on HS. All samples used in this analysis were obtained under protocols approved by the Cancer Institutional Review Board at the Ohio State University Medical Center.

We performed genome-wide linkage analysis using genotypes obtained with HumanCytoSNP-12 BeadChip (Illumina) in 13 samples (10 affected and three unaffected)

(Figure 1). Non-parametric linkage analysis with MERLIN v1.1.2 revealed at least four linkage peaks in 5p13, 9p24, 14q23, and 19p13, with similar linkage scores (maximum Z-scores of 16.5, 17.6, 16.8, and 16.8, respectively). We performed whole-genome sequencing (WGS) on blood genomic DNA from three family members (two affected and one unaffected) as depicted in Figure 1. After initial WGS data analyses with the Churchill method and BasePlayer 1.0.2 (Katainen et al., 2018; Kelly et al., 2015), we filtered variants with the following criteria: shared by the two HS patients, not present in the unaffected individual, and the minor allele frequency <0.001 in gnomAD database. We selected non-synonymous coding and splicing site variants and obtained 61 candidates, including 59 single-nucleotide variants and two small insertion/deletions. Fifty-nine of the variants were missense variants and two were potential splicing variants. To help choose between the candidate variants, we combined WGS with linkage analysis. Notably, we identified a heterozygous G>A transition in the 14q23 locus, at position +1 of the intron 8 donor splice site of the *SPTB* gene (NM_001024858.4:c.1064+1G>A).

To validate the *SPTB* c.1064+1G>A variant in the family, we performed Sanger sequencing on all the available DNA samples (n = 15) from the family (Table 1). Indeed, the variant was found in all the 12 HS patients we tested but was not present in the three non-affected individuals (Figure 1).

The c.1064+1G>A variant resides in the 5' essential splice site of intron 8 in the *SPTB* gene, which alters the canonical splice donor sequence and may cause exon skipping (Krawczak et al., 1992). To test whether the c.1064+1G>A variant affects *SPTB* splicing, we performed RT-PCR reactions with RNAs prepared from blood samples from family members. Samples of an unaffected individual and a HS patient produced an expected band of 584 bp in size, while cDNA of the HS patient produced an additional faint smaller sized band (Figure 2a). TOPO cloning and Sanger sequencing of this extra PCR product revealed exon 8 skipping (Figure 2b). To further validate exon 8 skipping, we designed a primer pair spanning the junction between *SPTB* exons 7 and 9 (Figure 2c). RT-PCR analysis revealed the presence of an approximately 245 bp amplicon in four HS patients as expected, but not in the unaffected individual (Figure 2d). Overall, the variant leads to the exclusion of exon 8 and subsequent frameshift in exon 9 and a premature stop codon. This variant is named SPTB NP_001020029.1: p.Ile294Serfs*35 according to the recommended variant nomenclature by the Human Genome Variation Society (Dunnen et al., 2016). The aberrantly spliced mRNA produced by the altered allele appeared to be unstable as it occurs as a very faint band compared with the wild type (Figure 2a). This observation suggests that the aberrant *SPTB* mRNA is subject to nonsense-mediated mRNA decay (Kurosaki & Maquat,). As seen in Figure 2e, translation of the altered allele would lead to a truncation

with a loss of all spectrin repeat domains, making it likely that haploinsufficiency of *SPTB* is underlying the HS risk (He et al., 2018). *SPTB* is an essential component of a complex spectrin-actin scaffold at the inner surface of the erythrocyte membrane and protects the stability of erythrocyte membranes (Machnicka et al., 2014). Pathogenic variants in the *SPTB* gene that have been associated with spherocytosis type 2 include nonsense, frame shift, splicing, and missense variants (Park et al., 2016; Salas et al., 2015).

In summary, we report a large five-generation family with 22 HS patients. A novel splicing variant (c.1064+1G>A) in the *SPTB* gene was detected by WGS and linkage analysis. Sanger sequencing of available genomic DNAs in 15 family members indicated that the variant was present in the 12 HS patients we tested, but not in the three unaffected individuals. The variant leads to the exclusion of exon 8 and subsequent frameshift and a premature stop codon. Different variants in the *SPTB* gene leading to HS have been reported, but this variant is novel and has not been found in any databases (Kopanos et al., 2018). We propose that this splice variant explains the spherocytosis phenotype observed in this large family.

ACKNOWLEDGMENTS

This article is dedicated to celebrating the life and accomplishments of Dr. Albert de la Chapelle (1933-2020). This study was supported (TTN) by Jane & Aatos Erkko Foundation and Päivikki and Sakari Sohlberg Foundation. We thank the family members for participation in the study.

CONFLICT OF INTEREST

The authors have no conflict of interest to declare.

AUTHOR CONTRIBUTIONS

T.T.N. and D.F.C. designed and performed the molecular experiments. P.B. helped with patient recruitment and clinical information. Y.W., W.L., and I.V.H. performed the experiments. T.T.N. and S.L. performed computer data analysis. T.T.N. and H.H. wrote the paper with input from D.F.C., S.L., P.B., and A.dI.C. A.dI.C. and H.H. conceived and designed the study.

DATA AVAILABILITY STATEMENT

The *SPTB* variant has been deposited in Global Variome shared LOVD (<https://databases.lovd.nl/>, Phenotype #0000235904).

ORCID

Huiling He  <https://orcid.org/0000-0002-5982-3250>

REFERENCES

- Andolfo, I., Russo, R., Gambale, A., & Iolascon, A. (2016). New insights on hereditary erythrocyte membrane defects.

- Haematologica*, 101(11), 1284–1294. <https://doi.org/10.3324/haematol.2016.142463>. Cited in: Pubmed; PMID 27756835.
- Da Costa, L., Galimand, J., Fenneteau, O., & Mohandas, N. (2013). Hereditary spherocytosis, elliptocytosis, and other red cell membrane disorders. *Blood Reviews*, 27(4), 167–178. <https://doi.org/10.1016/j.blre.2013.04.003>
- Delaunay, J. (2007). The molecular basis of hereditary red cell membrane disorders. *Blood Reviews*, 21(1), 1–20. <https://doi.org/10.1016/j.blre.2006.03.005>
- den Dunnen, J. T., Dalgleish, R., Maglott, D. R., Hart, R. K., Greenblatt, M. S., McGowan-Jordan, J., Roux, A.-F., Smith, T., Antonarakis, S. E., & Taschner, P. E. M. (2016). HGVS recommendations for the description of sequence variants: 2016 update. *Human Mutation*, 37(6), 564–569. <https://doi.org/10.1002/humu.22981>
- Gallagher, P. G. (2013). Abnormalities of the Erythrocyte Membrane. *Pediatric Clinics of North America*, 60(6), 1349–1362. <https://doi.org/10.1016/j.pcl.2013.09.001>. Cited in: Pubmed; PMID 24237975.
- He, B. J., Liao, L., Deng, Z. F., Tao, Y. F., Xu, Y. C., & Lin, F. Q. (2018). Molecular genetic mechanisms of hereditary spherocytosis: Current perspectives. *Acta Haematologica*, 139(1), 60–66. <https://doi.org/10.1159/000486229>
- Katainen, R., Donner, I., Cajuso, T., Kaasinen, E., Palin, K., Mäkinen, V., Aaltonen, L. A., & Pitkänen, E. (2018). Discovery of potential causative mutations in human coding and noncoding genome with the interactive software BasePlayer. *Nature Protocols*, 13(11), 2580–2600. <https://doi.org/10.1038/s41596-018-0052-3>
- Kelly, B. J., Fitch, J. R., Hu, Y., Corsmeier, D. J., Zhong, H., Wetzel, A. N., Nordquist, R. D., Newsom, D. L., & White, P. (2015). Churchill: an ultra-fast, deterministic, highly scalable and balanced parallelization strategy for the discovery of human genetic variation in clinical and population-scale genomics. *Genome Biology*, 16(1), 6. <https://doi.org/10.1186/s13059-014-0577-x>
- Kopanos, C., Tsiolkas, V., Kouris, A., Chapple, C. E., Albarca Aguilera, M., Meyer, R., & Massouras, A. (2018). VarSome: the human genomic variant search engine. *Bioinformatics*, 35(11), 1978–1980. <https://doi.org/10.1093/bioinformatics/bty897>
- Krawczak, M., Reiss, J., & Cooper, D. N. (1992). The mutational spectrum of single base-pair substitutions in mRNA splice junctions of human genes: Causes and consequences. *Human Genetics*, 90(1-2), 41–54. <https://doi.org/10.1007/BF00210743>. Cited in: Pubmed; PMID 1427786.
- Kurosaki, T., & Maquat, L. E. (2016). Nonsense-mediated mRNA decay in humans at a glance. *Journal of Cell Science*, 129(3), 461–467. <https://doi.org/10.1242/jcs.181008>. Cited in: Pubmed; PMID 26787741.
- Lux, S. E. IV (2016). Anatomy of the red cell membrane skeleton: unanswered questions. *Blood*, 127(2), 187–199. <https://doi.org/10.1182/blood-2014-12-512772>
- Machnicka, B., Czogalla, A., Hryniewicz-Jankowska, A., Bogusławska, D. M., Grochowalska, R., Heger, E., & Sikorski, A. F. (2014). Spectrins: A structural platform for stabilization and activation of membrane channels, receptors and transporters. *Biochimica Et Biophysica Acta (BBA) - Biomembranes*, 1838(2), 620–634. <https://doi.org/10.1016/j.bbamem.2013.05.002>
- Park, J., Jeong, D. C., Yoo, J., Jang, W., Chae, H., Kim, J., Kwon, A., Choi, H., Lee, J. W., Chung, N. G., & Kim, M. (2016). Mutational characteristics of ANK1 and SPTB genes in hereditary spherocytosis. *Clinical Genetics*, 90(1), 69–78. <https://doi.org/10.1111/cge.12749>
- Pesciotta, E. N., Sriswasdi, S., Tang, H.-Y., Mason, P. J., Bessler, M., & Speicher, D. W. (2012). A label-free proteome analysis strategy for identifying quantitative changes in erythrocyte membranes induced by red cell disorders. *Journal of Proteomics*, 76, 194–202. <https://doi.org/10.1016/j.jprot.2012.08.010>
- Salas, P. C., Rosales, J. M. L., Milla, C. P., Montiel, J. L., & Siles, J. L. (2015). A novel mutation in the β -spectrin gene causes the activation of a cryptic 5'-splice site and the creation of a de novo 3'-splice site. *Human Genome Variation*, 2(1), 15029. <https://doi.org/10.1038/hgv.2015.29>
- Wang, Y., Liyanarachchi, S., Miller, K. E., Nieminen, T. T., Comiskey, D. F., Li, W., Brock, P., Symer, D. E., Akagi, K., DeLap, K. E., He, H., Koboldt, D. C., & de la Chapelle, A. (2019). Identification of rare variants predisposing to thyroid cancer. *Thyroid*, 29(7), 946–955. <https://doi.org/10.1089/thy.2018.0736>

SUPPORTING INFORMATION

Additional supporting information may be found online in the Supporting Information section.

How to cite this article: Nieminen TT, Liyanarachchi S, Comiskey DF, et al. A novel essential splice site variant in SPTB in a large hereditary spherocytosis family. *Mol Genet Genomic Med*. 2021;9:e1641. <https://doi.org/10.1002/mgg3.1641>