



Since January 2020 Elsevier has created a COVID-19 resource centre with free information in English and Mandarin on the novel coronavirus COVID-19. The COVID-19 resource centre is hosted on Elsevier Connect, the company's public news and information website.

Elsevier hereby grants permission to make all its COVID-19-related research that is available on the COVID-19 resource centre - including this research content - immediately available in PubMed Central and other publicly funded repositories, such as the WHO COVID database with rights for unrestricted research re-use and analyses in any form or by any means with acknowledgement of the original source. These permissions are granted for free by Elsevier for as long as the COVID-19 resource centre remains active.



Contents lists available at ScienceDirect

Automation in Construction

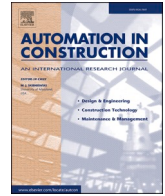
journal homepage: www.elsevier.com/locate/autcon

Modular composite building in urgent emergency engineering projects: A case study of accelerated design and construction of Wuhan Thunder God Mountain/Leishenshan hospital to COVID-19 pandemic

Ling-Kun Chen^{a,b,c,*}, Rui-Peng Yuan^a, Xing-Jun Ji^d, Xing-Yu Lu^a, Jiang Xiao^a, Jun-Bo Tao^e, Xin Kang^a, Xin Li^f, Zhen-Hua He^g, Shu Quan^h, Li-Zhong Jiangⁱ

^a College of Civil Science and Engineering, Yangzhou University, Yangzhou, Jiangsu 225127, China

^b School of Civil Engineering, Southwest Jiaotong University, Chengdu, Sichuan 610031, China

^c Department of Civil and Environmental Engineering, University of California, Los Angeles, CA 90095-1593, USA

^d Jiangsu Zipi Engineering Technology Co. LTD., Jiangsu Donghai 222322, China

^e School of Management, Harbin Institute of Technology, Harbin, Heilongjiang 150001, China

^f China Construction Fifth Engineering Bureau Group Co., LTD., Anhui branch, Hefei, Anhui 230001, China

^g Central and Southern China Municipal Engineering Design & Research Institute Company Ltd, Hubei, Wuhan 430010, China

^h China Construction Third Engineering Bureau Group Co., LTD., Wuhan, Hubei 430064, China

ⁱ School of civil engineering, Central South University, Changsha 410075, Hunan, China

ARTICLE INFO

Keywords:

Wuhan Leishenshan hospital
Modular composite building
Off-site building modular units
Light steel structure
Accelerated design and construction
Building information model (BIM) technology
Unmanned aerial vehicles (UAVs)

ABSTRACT

Wuhan Leishenshan/Leishenshan (“Leishenshan” for short) hospital is a makeshift emergency hospital for treating patients diagnosed with the novel coronavirus-infected pneumonia (NCIP). Engineering construction uses modular composite building finished products to the greatest extent, which reduces the workload of field operations and saves a lot of time. The building information model (BIM) technology assists in design and construction work to meet rapid construction requirements. Besides, based on the unmanned aerial vehicles (UAVs) data analysis and application platform, digitization and intelligence in engineering construction are improved. Simultaneously, on-site construction and overall hoisting were carried out to achieve maximum efficiency. This article aims to take the construction of Leishenshan Hospital as an example to illustrate how to adopt BIM technology and other high-tech technology such as big data, artificial intelligence, drones, and 5G for the fast construction of the fabricated steel structure systems in emergency engineering projects.

1. Introduction

The assembly building is the product of the development of building industrialization. Since the 1970s, different countries and regions have chosen different development paths and methods based on various natural and human conditions and characteristics [1,2]. Japan put forward the concept of prefabricated house in 1968. In 1990, the production system of medium and high-rise residential buildings was launched, which adopts the component-based, industrialized production mode, high production efficiency, variable internal structure of residential buildings, and adapts to residents' different needs [3,4]. American prefabricated housing prevailed in the 1970s. In 1976, the U.S. Congress passed the national manufactured housing construction and Safety Act and issued a series of strict industry standards in the same year, which

have been used up to now [5]. There are already studies on the construction of space modular hospitals in foreign countries.

The so-called space modular hospital is prefabricated. During construction, to meet the building's functional requirements, according to the building's operational characteristics, different prefabricated steel structure systems are used to assemble a modular house with unique functions (such as ward modules), Diagnosis room module, medicinal material library module) [6]. HKS architectural design company of the United States has advanced design results in the unit ward [7]. The trans-modular hospital systems launched by GOLD (Global Ocean and land developers) Company in the United States have put modular hospital construction into practice. The space of each department in the system is presented as an independent module of equal size. After complete prefabrication, it is transported to the destination site as

* Corresponding author at: College of Civil Science and Engineering, Yangzhou University, 198 West Huayang Road, Yangzhou, Jiangsu 225127, China.

E-mail address: lingkunchen08@hotmail.com (L.-K. Chen).

<https://doi.org/10.1016/j.autcon.2021.103555>

Received 30 May 2020; Received in revised form 27 October 2020; Accepted 18 December 2020

Available online 22 January 2021

0926-5805/© 2021 Elsevier B.V. All rights reserved.

required to realize the hospital's combined construction. In 2015, in the competition of therapeutic facilities organized by UIA-PHG, we also discussed the future trend of therapeutic facilities based on the concept of prefabricated removable therapeutic space unit against the infectious disease outbreak background.

IFS Global Industry Director Kenny Ingram pointed out in the 2019 industry development forecast that modular buildings and integrated building manufacturing are playing an increasingly important role all over the world [8]. It is estimated that by 2022, modular products will grow by 6% globally, and some of these countries are already leading the way in prefabricated buildings [9]. Sweden is a model of modular home architecture—84% of individual houses in Scandinavian countries use prefabricated timber structures [10]. In the United States, Australia, and the United Kingdom, this figure is only 5%. Sweden is a world leader in modular construction [11].

In China, however, prefabricated buildings suddenly stagnated in the late 1980s and now rise again after more than 30 years of silence. The construction of Huoshenshan and Leishenshan hospital has made more people see the potential of prefabricated buildings in China. The assembly construction can effectively compress the building's construction cycle; the light modular architecture can break away from the requirements of the construction for the site and meet the needs of the functional space of the emergency hospital, which is of vital importance in response to public health emergencies. Matching buildings may be the future of the rapid deployment of healthcare. Because the function of unique structures in the extraordinary period is more excellent than everything else.

The prefabricated buildings assembled with prefabricated parts are safe. Because the prefabricated components are collected in the factory's controlled environment, designers and constructors can eliminate all problems before entering the construction site and ensure that all modular contractors' can be a beginning the construction site. In contrast, traditional buildings rely more on the weather and contractors' activities at different levels in the whole project [12,13].

The prefabricated buildings or so-called "modular structures" are also being used in emergency therapeutic plans in other parts of the world. For example, the "architecture + health" project of Clemson University in the United States is testing whether it is feasible to connect containers in series to assemble rapid response therapeutic facilities [14]. It has been commented that the progress of this technology "may be the future of rapid deployment of health care" [15].

It is worth noting that the prefabricated building's design process did not fully consider the needs of the actual production and installation of the components, resulting in the design and construction conflicts and construction collisions when entering the component production and installation links [16,17]. The design collision Changes will eventually lead to phenomena such as suspension of work at the construction site, which will affect the construction period and quality of the construction project. Therefore, coordinating the relationship between design and construction and making information flow between all stages and participants has become the key to solving management problems in the construction process [18,19].

The emergence and development of the concept of building information modeling (BIM) provide a technical platform for sharing engineering information at all stages and better realizes the collection, transmission, and feedback of data [20]. With the help of BIM technology, the various design, manufacturing, and installation requirements can be considered comprehensively, and the virtual construction of the project can be realized through the BIM model, including design coordination, installation simulation, schedule simulation, etc. to reduce possible problems [21,22].

Unlike the hospital building, such as the Paimio tuberculosis sanatorium built-in 1933 in Finland, the former is mainly due to its beautiful shape and suitable materials. "When we design a permanent hospital, we need to consider the complete functions and the applicability of the building in the next 75 years [23,24]. At present, Wuhan has no such

luxury in designing new hospitals. The novel coronavirus is not the case, but the "isolation center for management of infection." Fig. 1 shows the Leishenshan hospital under construction. The Wuhan Leishenshan hospital is a temporary emergency hospital for diagnosing and treating and treating and treating new coronavirus pneumonia patients. Three different fabricated steel structure systems are used to adapt to the building's functional characteristics and meet the requirements of rapid construction. Through this project's approach, the rationality of structure selection and reliability of the design is verified. Raytheon mountain's implication is that as buildings with "more functions than everything," [25] they are not built for the sake of passing on. Still, because of the unique time point and the witness of the whole people in the live broadcast, they may also be recorded in architectural history [26].

2. Project overview

In January of 2020, Wuhan City Disease Prevention Headquarters agreed to construct Leishenshan hospital within half a month. The former 2019 Military World Games (MWGs) athlete restaurant has been converted into Wuhan's second hospital devoted to treating patients diagnosed with the coronavirus disease 2019 (COVID-19), causing novel COVID-19-infected pneumonia (NCIP)—Leishenshan hospital, situated in MWGs Village, Jiangxia Area. One thousand six hundred beds were freshly constructed. Leishenshan hospital was designed by Zhongnan Architectural Design Institute, organized by Wuhan Real Estate Group, and constructed by China Construction Third Engineering Bureau as a general contractor. See Fig. 2 for an introduction to the Leishenshan hospital.

The size of the Wuhan Leishenshan hospital is more extensive than the two Huoshenshan hospitals. In normal conditions, a hospital of this scale can only be constructed in 3 to 5 years, and Leishenshan hospital had to be placed into service in 2 weeks. Still, the building time was relatively the same as Huoshenshan hospital. At the building's peak construction time, more than 1500 pieces of machinery and equipment were built for more than 10,000 employees. For February 4, 2020, 96.5 percent of the raising of box-type wards was completed, more than half of the road hardening was completed, the remainder of the base of supporting usable rooms such as liquid chlorine dosing area, liquid oxygen unit, positive and negative pressure station house, etc. were completed, the construction of machinery and plumbing of the sewage treatment station was completed, and the structure of the waste incineration station was also completed. About 1,025 building supervisors, 7,906 construction workers, and 1,491 pieces of excavators, cranes, and other machinery and equipment are placed into construction.

The biggest challenge for the construction of Leishenshan hospital is the tight time and heavy tasks. As an infectious disease hospital with 1500 beds and a total construction area of 79,000 m², it needs to be completed and delivered in more than ten days, which is equivalent to 3 to 5. The year's construction tasks were compressed into more than ten days. Therefore, modular composite buildings' use, industrialized, and prefabricated construction methods are inevitable for project construction.

The construction requirements for emergency service projects are high, and the design and construction period is short. The conventional civil construction process is difficult to meet the needs. Traditional civil construction procedures are usually carried out layer by layer from top to bottom. After the roof is capped, the enclosure structure, equipment, pipelines, etc. can be constructed. The interior decoration can only be started after the top and external walls are closed. In this case, it is often necessary to complete the previous process before proceeding to the next cycle. Conclusion this construction method has a long construction period, low flexibility, and complicated preparations.

The design and construction methods of prefabricated modular box buildings are different. It uses a room as the basic unit and is relatively independent in structure and structure. The dimensional error between



Fig. 1. Leishenshan hospital under construction. Photo provided by Huang Lei.

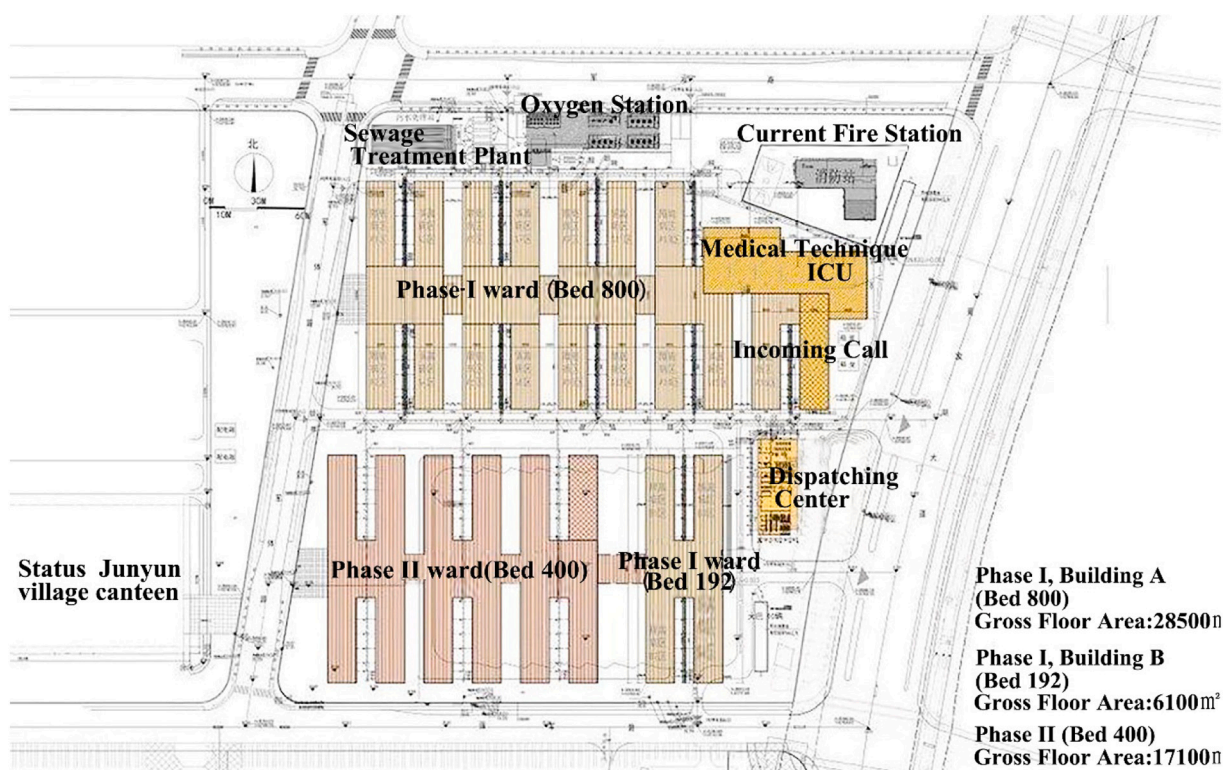

Fig. 2. Introduction of Leishenshan hospital project.

other systems will not affect the completion and overall use of building construction. At the same time, it can also be constructed in parallel on-site, combining conventional serial processes. The process becomes parallel, which significantly shortens the construction time. Considering the purpose and urgent construction period requirements of the new crown epidemic emergency service project, the use of prefabricated modular box buildings can meet the demand to the greatest extent and fully reflect the advantages of prefabricated buildings of “light, good, fast, energy-saving, energy-saving and environmental protection.”

3. Architectural planning and design

Wuhan Leishenshan hospital is located north of Qiangjun Road, 2019 MWGs village, Jiangxia District, which is idle after the 2019 MWGs. There is already a 300mm thick concrete hardened ground, which can be used as a basic cast-in layer for the isolation medical area, significantly

reducing the workload of site leveling and speeding up Leishenshan hospital's construction. The field is adjacent to the 10,000-person canteen of MWGs Village. The municipal supporting facilities are relatively complete. The site is flat and has a hardened floor, which is very suitable for constructing temporary buildings.

Simultaneously, the roads around the site are open, the traffic is perfect, and it is far away from the central urban area. The surrounding area is not yet developed and mature, with closed control and isolation conditions.

The Leishenshan hospital covers an area of 21.87 ha, with a building area of 79,900 square meters. After completion, it provides 1600 therapeutic beds, which can meet 2300 therapeutic and nursing personnel's needs. The therapeutic isolation area is about 51,000 square meters, and the therapeutic accommodation area is about 9000 square meters. As shown in Fig. 3, the modular design is adopted in urgent emergency engineering projects for the Leishenshan hospital, including a

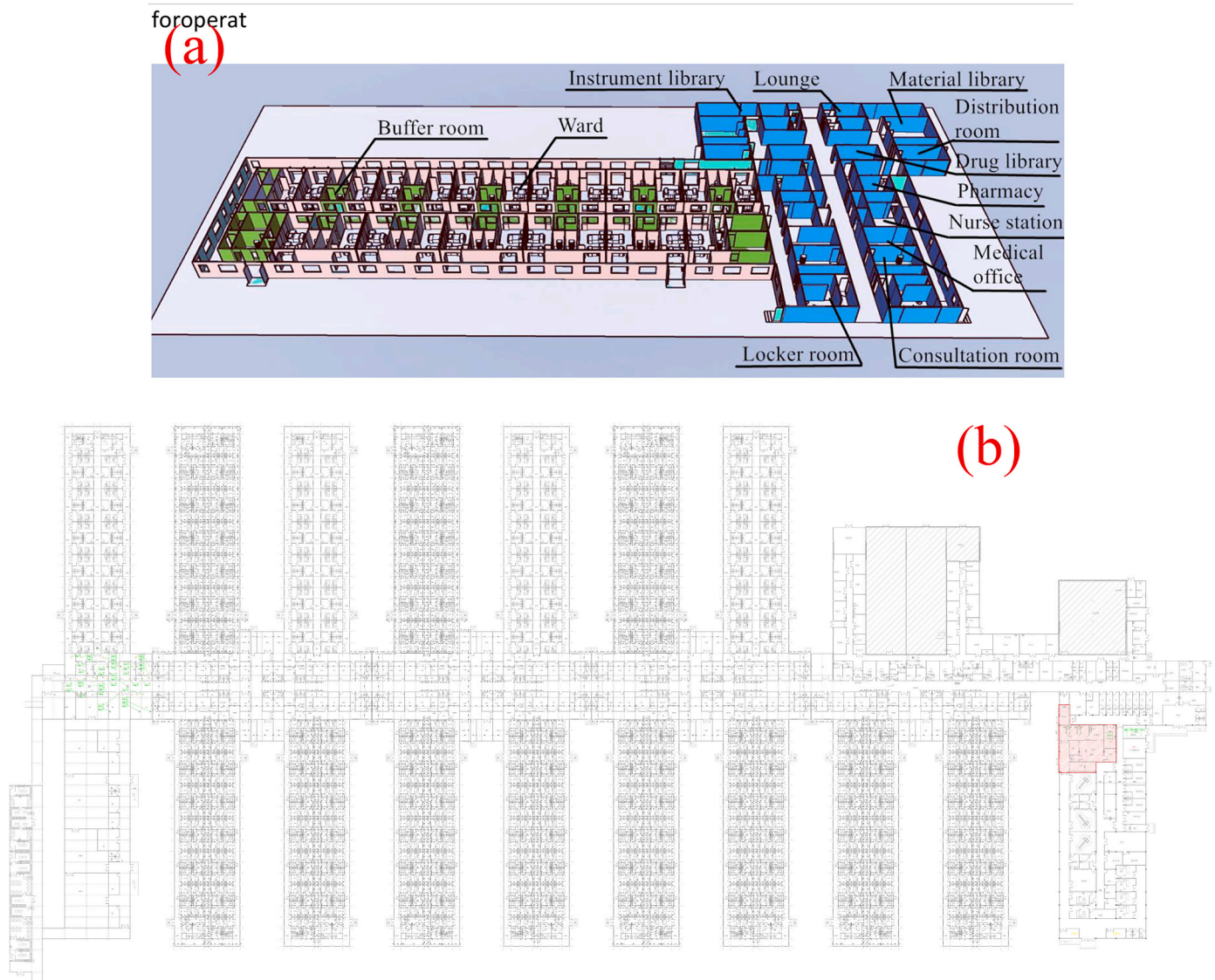

Fig. 3. The nursing unit module of the isolated medical area. (a) Schematic diagram, and (b) unit plan.

therapeutic isolation area, therapeutic staff living area, and a general logistics area. The therapeutic field and the therapeutic living area have been isolated relatively independently, and strict streamline of the therapeutic care, patient, logistics, and sewage have been planned to prevent pollution. The distance between the overall building and the surrounding roads and other buildings shall meet the infectious disease hospital's requirements. Air conditioning exhaust and sewage are discharged after disinfection, and rainwater is released to the sewage pipe network after collection and disinfection.

Since novel coronavirus is highly infectious, the standard of sewage treatment technology in Leishenshan hospital is higher than that in general contagious disease hospital. According to landfill standards, a layer of High-density polyethylene (HDPE) anti-seepage membrane was laid in the hospital area. The membrane is a kind of flexible waterproof material with a high anti-seepage coefficient, excellent heat resistance, and cold resistance. It is equivalent to putting a layer of "protective clothing" on the whole hospital plot to ensure the above-ground structures' physical isolation above-ground structures' physical isolation from the groundwater and soil. The hospital area is equipped with a sewage treatment station, the disinfection tank, the integrated regulating tank, the biochemical tank, the efficient sedimentation tank, and other environmental protection facilities.

The construction of Leishenshan hospital mainly uses containers for modular assembly to form various functional modules of the hospital and uses BIM technology to assist in automated construction. In the prefabricated container stage, the building and structural components are integrated and classified in the digital model, and the factory production is directly automated and guided. In the construction stage, use BIM technology to digitally simulate the on-site construction process to find the best assembly plant, and digitally number the modules according to the function and assembly sequence. The on-site construction personnel follows the BIM simulation sequence, and structural requirements to carry out construction like piled wood Construction dramatically shortens the construction time.

4. Structure design

4.1. Superstructure design

The structural design of emergency hospitals must ensure safety and be completed in a short time. Therefore, modular containers are used to assemble medical units. For the ICU and medical, the technical department with special requirements, light steel structure, and steel composite panels are used for assembly.

The container adopts a steel structure skeleton and color steel composite board wall as a whole. The mainframe beams and columns are made of cold-formed steel welding. The six sides are welded with cold-formed steel with a 500–1200 mm distance to ensure the wall's strength, strength, and top and bottom plates. Stable. The structure has strong integrity, high bearing capacity, wind resistance, earthquake resistance, safety, and durability through the welding connection. Most of the enclosure materials used are color steel plate finishes, and filler materials such as glass fiber insulation cotton are included to form composite wall panels, top panels, and bottom panels. The box roof is equipped with a waterproof and thermal insulation system, and drainage systems are hidden in the four corners. Container-style house units can be diversified and spliced according to user needs. The box is the basic unit and can be used alone or combined horizontally and vertically to form a spacious use space and stacked vertically.

According to the production conditions of the manufacturer at the time, Leishenshan Hospital adopted two box-type room units with dimensions of $3\text{ m} \times 6\text{ m} \times 2.9\text{ m}$ and $2\text{ m} \times 6\text{ m} \times 2.9\text{ m}$. The building plan was arranged according to the basic Company. The height of the medical technology area in the isolated medical area is 4.3 m. Because the plane column network is not uniform and the partial span reaches 18 m, the prefabricated systems such as box-type houses and slab-type houses cannot meet the requirements, so the steel frame structure system is chosen.

Fig. 4 shows the nursing unit module of Leishenshan Hospital. All modules are prefabricated in the factory, transported to the roads around the site, assembled outside the area, and hoisted. Small pipelines

inside the ward modules are reserved and embedded simultaneously. Some unique function rooms, such as pharmacies, use boxes as the basic unit, forming a spacious use space through different horizontal and vertical directions.

4.2. Three zones and two channels

The entire Leishenshan Hospital adopts a “Three zones and two channels” structure. The three zones refer to clean, semi-contaminated and contaminated areas, and the two channels refer to the patient channel and the medical care channel. The isolated medical area is a new temporary building, including 30 isolation wards and two intensive care units. There is a sanitary passing unit, ward nursing unit, medical technology unit, and reception area, excluding outpatient and emergency departments. Fig. 5 shows the medical technology unit module of an isolated therapeutic areas.

The ward nursing unit is a light combined modular building, and the medical technology area is a steel frame and light wall panel building combined structure. The plan is a “fishbone” layout, and each “fishbone” is an independent medical unit. The ward is divided into north and south areas, each with 15 wards, and the ward spacing is 12 m. Multiple H-shaped modules arrange the wards. Among them, the office area and medical staff passage are placed along the central axis. Each central module is responsible for four. There are two rows of wards in the nursing unit—patients from the ward outside the ward. Medical staff enters the ward through the “sanitary passage unit” from the central axis's core through disinfection, dressing, and inspection to perform the

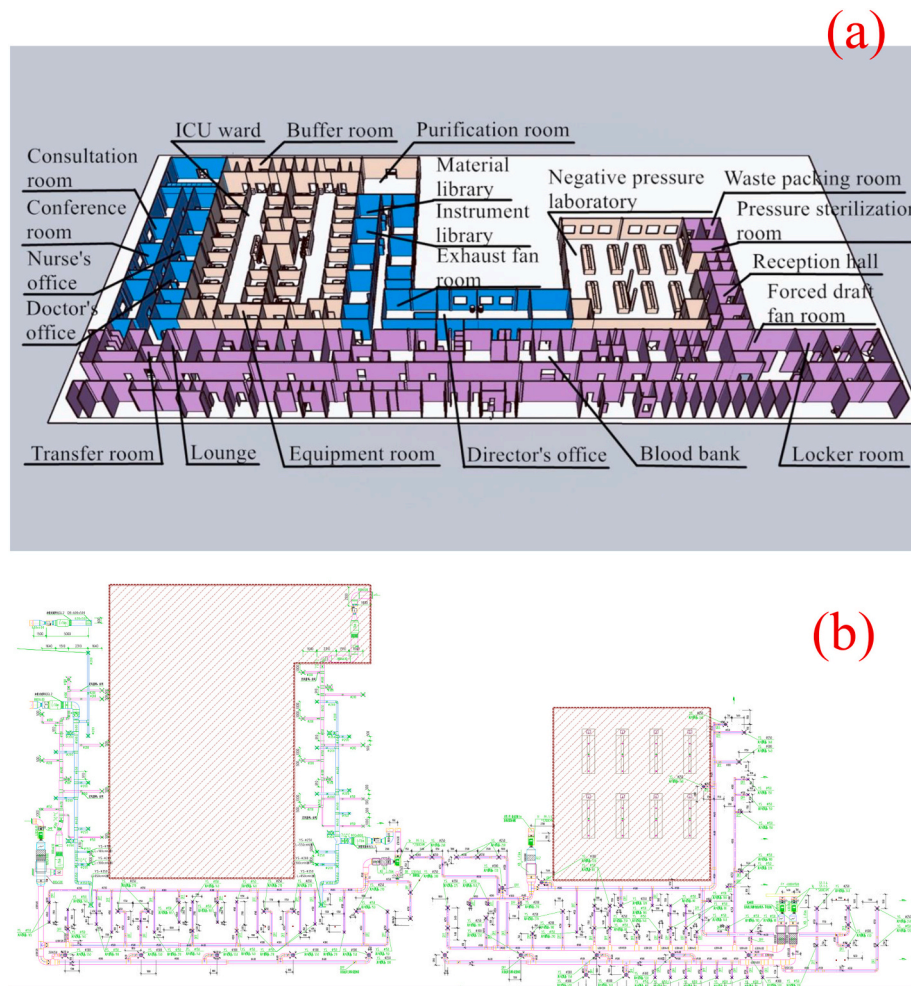

Fig. 4. Medical technology unit module of isolated therapeutic area. (a) Schematic diagram, and (b) unit plan.

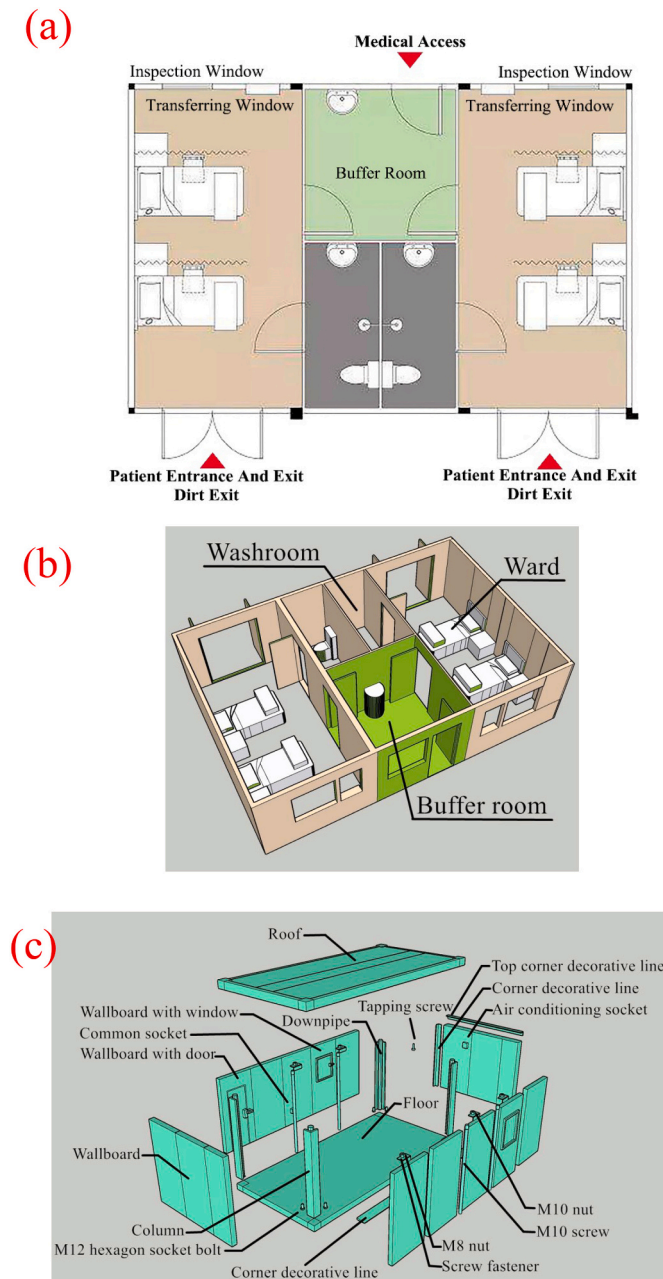

Fig. 5. Nursing unit of the isolated therapeutic area. (a) unit plan, and (b) schematic diagram of box room module components.

assessment, treatment, and nursing work. Control the cleanliness of the air to avoid cross-infection. It is worth noting that the isolation medical area uses a negative pressure isolation ward, meets the performance requirements of various buildings.

The medical and nursing living area has two floors, and a light steel portable board room system different from the ward area is adopted according to the building plan and space requirements. The plane size of the standard room unit is 3640 mm × 5460 mm. The main structure of the light steel movable board house is a lightweight steel frame, and there are cross cables between the frames to ensure the rigidity and stability of the structure; the floor supporting system adopts a light steel truss with a wooden floor on it; the roof and wall enclosure adopt sandwich color steel plate. The mobile board house has a mature technology system, adopts standardized and modular production, is very convenient for installation and disassembly, and has a flexible layout. It has obvious advantages as a temporary indoor building. Hushenshan

and Leishenshan hospital's key bodies are designed with light steel frameworks, if Hushenshan hospital uses a container house as a building module unit, while Leishenshan hospital as a building module unit is a steel frame. Fig. 6 shows the assembled Leishenshan hospital's steel frame module.

The nursing unit of isolated therapeutic areas is shown in Fig. 7. The nominal size modular units of 3.0 m × 6.0 m × 2.9 m and 2.0 m × 6.0 m × 2.9 m are selected for the project, and the building plane is arranged according to the necessary unit modulus. The company combined house's modular unit adopts a steel structure framework and color steel composite plate wall as a whole. The frame is mainly made of cold-formed thin-walled sections, which are connected by welding. The structure has strong integrity and high bearing capacity. The module unit can be diversified and spliced freely according to the user demand. The essential company is the box, which can be used alone or removed from the wall panel. The spacious use space is formed by different combinations of horizontal and vertical directions. It can be stacked vertically, generally no more than three layers.

4.3. Foundation design

The isolation area is located in the first parking lot or green belt area. There is a hardened floor in the original parking lot area, and the isolation area foundation is shown in Fig. 8.

The original permanent story shall be used as much as possible in the design. In the green zone without a hardened floor, the soil layer's distinctive amount of bearing capacity shall be checked to reach 60kpa at least. Otherwise, sand and stone cushion shall be used for replacement. Then cast in situ 200 mm thick C30 concrete hardening layer, built-in single layer, and two-way 12 @ 200 reinforcing mesh. First, the hardened floor of the whole site area will be formed as a whole, and then the buttress or raft will be made according to the layout of the superstructure in the later stage. Fig. 9 shows the constructional details of the isolation area foundation. On the one hand, it solves the pillow of structural foundation or raft; on the other hand, it creates right conditions for laying high-density polyethylene (HDPE) anti-seepage membrane in the whole site.

The nursing unit's self-weight in the ward is light, and the hardened floor can directly bear the upper load. The foundation layout of the common area is shown in Fig. 10. The therapeutic technology area adopts a steel frame structure system, and the reaction force at the bottom of the column is large. If the hardened floor is difficult to meet the local stress requirements, a 300 mm thick reinforced concrete composite layer is poured on the set floor to form a laminated flat raft foundation. Its specific structure is shown in Fig. 7. (b).

5. Accelerated construction

The whole construction process uses BIM technology to assist the construction. Before constructing the project, it is necessary to draw a design drawing and establish a BIM model. Including formulating design standards, establishing models, and model applications. The BIM model's establishment needs to complete the design of the structure type, size, and material parameters according to the prefabricated building's detailed requirements. At the same time, use relevant technology to control all parameters. If the input data changes, its related data will also change. In this way, the probability of drawing errors is reduced, and the overall drawing design level is improved.

5.1. Construction process

The whole construction process of the Leishenshan hospital only takes 12 days, from January 26, 2020, to February 6, 2020. The specific construction process is roughly divided into the following stages: site leveling → ② pipe trench excavation, local backfilling → ③ site hardening floor construction → ④ HDPE membrane construction → ⑤ strip



Fig. 6. Isolation area foundation.

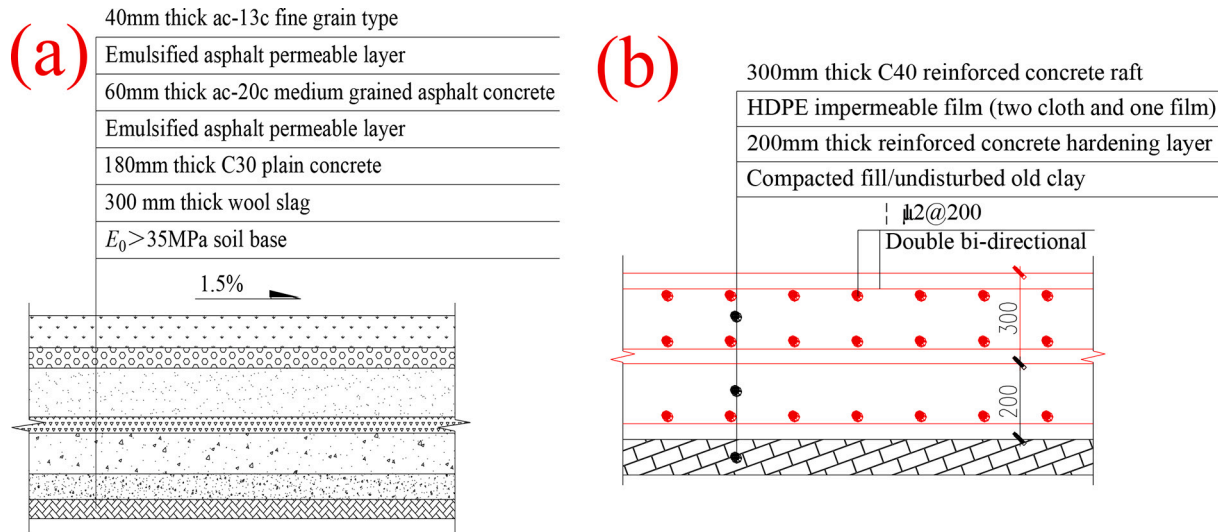

Fig. 7. Constructional details of isolation area foundation. (a) Construction method of the hardened floor in the parking lot area, and (b) structural sketch of laminated flat raft foundation.

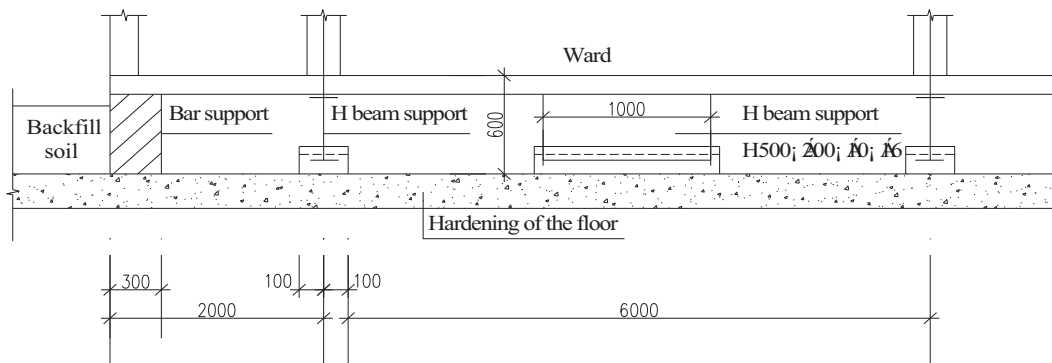

Fig. 8. Foundation layout of a typical area of ward nursing unit.

and shaped steel buttress, raft foundation construction → ⑥ box house installation, steel structure installation → ⑦ wall partition and roof installation → ⑧ pipeline installation and decoration → ⑨ therapeutic equipment and furniture installation and commissioning. The construction schedule is shown in Table 1. The scene of some construction stages is shown in Figs. 9, and 10.

According to the construction process of Leishenshan Hospital described in Table 1, it can be found that the BIM simulation platform can classify and save engineering information, use the model to call up the required information, such as door and window statistics, connector types, and other information, and provide the manufacturer with corresponding processing drawings and schedules. Simultaneously, a

scientific transportation plan is formulated to ensure that the prefabricated components arrive at the construction site on time.

Make full use of the BIM site model, achieve visual layout, and judge whether the construction site's design is reasonable and whether the material storage yard's area meets the requirements. Simultaneously, it can view the site model's dynamic change information in time according to the project schedule and adjust the unreasonable layout. After being put into use, the BIM intelligent system is used to monitor the medical staff's working environment in real-time, effectively enhancing emergency facilities' management ability.



Fig. 9. Construction site drawing (I).



Fig. 10. Construction site drawing (II)

5.2. Construction technology

In addition to the BIM technology used in the entire construction process for auxiliary construction, other construction techniques used by Leishenshan Hospital include:

First of all, drone high-altitude time-lapse photography is used to reproduce the construction process as a whole at high altitude with a broader perspective, providing customized panoramic construction site tracking. Provide efficient and accurate earthwork measurements. Drive the drone to automatically collect target plot information, synchronize the acquired data to the cloud, and calculate the amount of earthwork by establishing a high-precision model and efficient cloud computing. Based on the unmanned aerial vehicles (UAVs) data analysis and application platform, digitization and intelligence in engineering construction are improved.

Second, provide a full range of project image progress management, and offer a full-cycle safety management model. Through drone inspection and monitoring, the on-site construction situation and progress are reflected in real-time and intuitively on the manager's software side, and the detailed data of different stages of construction can be clearly understood so that the manager can review the project diary; in case of abnormal situations, It can track or reproduce the construction process analysis cause in time, avoid construction engineering disputes, and reduce the occurrence of engineering safety accidents.

5.3. Industry trend

During the construction process of Leishenshan hospital, we can see that many container-style off-site building modular units have been put into actual use. The application of off-site unit building models favored in Europe in China has undoubtedly become historical—A new milestone in meaning— Digital and diversified construction companies will get more development opportunities.

Trend 1: The construction industry will continue to innovate through digital technology. Big data, artificial intelligence, drones, 5G, and other high-tech applications are put into use, including the application of drones in engineering construction, from the familiar time-lapse photography function to the provision of data services to assist decision-making, and the value of "air brain" cannot be underestimated. In the future, in the intelligent transformation of the real estate industry, drones' application scenarios will be more extensive and in-depth. UAVs can obtain data and remotely link other information technology (IT) devices to improve human-machine collaboration efficiency and help enterprises. Refined management.

Trend 2: Drive technology companies to more densely cooperate with traditional real estate companies. Construction companies must diversify—they need to be both manufacturers and builders, they need their IT systems to be significant enough to provide opportunities for dialogue with each other, and most critically, they need to become service companies to keep maintenance operations and Retain

Table 1
Construction schedule.

Time	Construction Schedule	Common project design	Technical advantages of the Leishenshan Hospital project
January 26	Leishenshan Hospital has completed the general building plan, the necessary drawings of the six nursing units, and the available water and electricity drawings. It has provided the construction unit for on-site construction.	Ordinary project design does not use BIM technology, and it is impossible to simulate the design plan and construction plan in advance. During the formal construction, it is easy to encounter difficulties in design and construction, which consumes a lot of construction time.	Use BIM technology to assist the design, directly use the detailed drawing deepening software Tekla for modeling, import the model into available finite element software for calculation, and now express the design results in detail, convenient for docking with construction materials optimize several construction plans. Reduce construction time and improve construction efficiency.
January 27	The site leveling work is completed. Pipeline trench excavation, trench drain, sewage pipeline pre-buried installation, trench-graded sand and gravel backfill, and the pre-buried start of the mechanical and electrical channels in the wing area partial foundation concrete pouring.	It is impossible to simulate the construction route and plan in advance. According to the design drawing, the construction is prone to construction problems, which will cause the building to be interrupted or cause conflicts between the later facility and the embedded pipeline. The structure takes about 20 days.	Using BIM technology to simulate pipeline trench excavation in advance, pre-buried installation of trench rain and sewage pipelines, trench-graded sand and gravel backfill, reserved pre-buried electrical channels the wing area, and other construction project lines and processes to prevent on-site construction problems Stagnantly.
January 28	Excavation of pipeline trenches in the medical isolation area and installation of Bailey beams have been completed, earthwork backfilling and HDPE membrane construction have been started. Board houses have been built in the accommodation area for medical staff.	The construction plan is not simulated in advance, and the HDPE film is not used. The anti-leakage effect is average, and the groundwater seepage of the structure is likely to occur. The construction time is about 15 days.	Use BIM technology to simulate pipeline trench excavation, Bailey beam installation, earthwork backfilling, HDPE membrane construction process in advance to speed up the construction speed. Three layers of isolation protection, including the concrete base layer, anti-seepage membrane, and reinforced concrete ground layer, ensure that the above-ground structures are separated from each other. Groundwater and soil are physically separated.
January 29–February 1	The strip foundation of Leishenshan Hospital has been completed, and the supporting power project of Leishenshan Hospital has been completed. The progress of container installation in the quarantine area reached 60%. The total construction progress reached 65%, and it took four days.	The housing construction adopts a typical reinforced concrete structure with a construction period of 3–5 years.	The container is modularized and assembled into various functional unit modules, and then the hospital's main body is composed of available modules. The prefabricated modular construction of light steel structure significantly saves construction time. The strip foundation layout and container assembly and modification work are carried out at the same time, which dramatically improves construction efficiency.
February 2–February 6	The container installation of Leishenshan Hospital has been completed, and the structure of medical equipment has been completed. Leishenshan Hospital officially passed the Wuhan City Construction and Health Department's acceptance and began to be gradually transferred. It took six days.	The housing construction adopts a typical reinforced concrete structure with a construction period of 3–5 years.	The container is modularized and assembled into various functional unit modules, and then the hospital's main body is composed of available modules. The prefabricated modular construction of light steel structure significantly saves construction time.

customers and improve the digital level of the entire construction engineering industry.

Trend 3: Off-site construction will increase. Studies have shown that the construction industry is lagging in technology adoption. If existing companies want to protect themselves, then change is the key.

6. Conclusions

Leishenshan hospital is a temporary therapeutic facility to deal with a major epidemic. First of all, we should overcome the problems of heavy jobs, fast time, and high requirements in terms of design. Secondly, in construction, it benefits from the efficient coordination ability of design and construction organization and the more sophisticated light steel structure assembly modular building industry system. Using BIM technology to assist in the whole process of design and construction, pre-simulating the design plan and construction plan, and using structural assembly modular construction technology, the large-scale construction was successfully completed in a relatively short period of time t. According to the design and construction practice of the Leishenshan hospital, the following suggestions are provided for reference:

- (1) BIM technology can realize the construction of an information interaction platform and achieve various information sharing and engineering design coordination. Leishenshan's BIM model creation is based on this function, and hundreds of designers from

across the country share information and jointly complete the model creation. Different types of design models can be processed on the information interaction platform in a timely and effective manner, the interaction and combination of models can be achieved, and collaborative design can be realized.

- (2) In the early stage of the Leishenshan hospital project's design, a three-dimensional information model was constructed using BIM software to visualize the relationship between the building and the site, and the site leveling and spatial positioning were performed according to the analysis results. Use BIM technology to realize site layout planning and design efficient-efficient design solutions. So as to provide technical support for rapid construction.
- (3) Standardized design is the core and premise of promoting the industrialization development of prefabricated buildings. Standardized production and regulated assembly must be realized through a standardized method. It is necessary to simplify the design process and coordinate the construction at the same time. Space and load requirements of the electromechanical pipeline and other equipment shall be fully considered in the structural design. At the initial stage of design, good communication shall be conducted with the construction party in terms of the construction period, processing and transportation, human resources and equipment, material supply, on-site construction method,

etc., so as to reduce the situation of on-site adjustment and modification of the scheme.

- (4) In hospitals' construction, digital models enable companies to monitor the entire construction process, using large amounts of high-tech technology such as big data, artificial intelligence, drones, and 5G. Modular construction can increase construction speed by more than 50% while reducing costs. Off-site construction is a real game-changer. It can increase productivity because different construction tasks can be completed at the same time. It provides customers with a comprehensive construction model.
- (5) The design experience of the Xiaotangshan Hospital in 2003 is used for reference by the Leishenshan hospital. Still, the scale, function, technology, and materials of the construction are further improved, and the industrialization degree of the assembly system adopted is higher. The Xiaotangshan Hospital is a quick way to build therapeutic space in the form of a movable plank house, a means to fight in an emergency. The actual use of the space room's state and physical conditions does not fully meet therapeutic use standards. In the experience accumulation and post epidemic reflection of the Leishenshan hospital, the criteria and details of the prefabricated construction system of the disaster response therapeutic space are considered in-depth, which provides experience for emergency construction under the background of frequent natural disasters and infectious diseases.

Declaration of Competing Interest

Please check the following as appropriate:

- o All authors have participated in (a) conception and design, or analysis and interpretation of the data; (b) drafting the article or revising it critically for important intellectual content; and (c) approval of the final version.
- o This manuscript has not been submitted to, nor is under review at, another journal or other publishing venue.
- o The authors have no affiliation with any organization with a direct or indirect financial interest in the subject matter discussed in the manuscript
- o The following authors have affiliations with organizations with a direct or indirect financial interest in the subject matter discussed in the manuscript:

Acknowledgments

This research is supported by the National Key R & D Program under Grant No. 2018YFC1504306; the Special Application Plan for the Construction of National Emergency Management System Grant No. 2020YJ0331030; the Hunan Innovative Provincial Construction Project under Grant No. 2019RS3009; the National Science Foundation of China under Grant No. 51778630; the China Postdoctoral Science Foundation under Grant No. 2015M581702, and 2016M592695. The corresponding author thanks the 2018 Jiangsu Provincial Government Scholarship Program (No. 228) to support his visit to the University of California, Los Angeles. Moreover, the authors are also grateful to Central-South Architectural Design Institute Co., Ltd., China Construction Third Engineering Bureau, and China Construction Fifth Engineering Bureau for providing design drawings and construction photos.

References

- [1] A.W. Lacey, W. Chen, H. Hao, et al., Effect of inter-module connection stiffness on structural response of a modular steel building subjected to wind and earthquake load, *Eng. Struct.* 213 (2020) 110628, <https://doi.org/10.1016/j.engstruct.2020.110628>.
- [2] F. Taboas, F. Comino, M.R. de Adana, Experimental study of a modular unglazed transpired collector Façade for building refurbishment, *Sol. Energy* 201 (2020) 247–258, <https://doi.org/10.1016/j.solener.2020.02.103>.
- [3] Y. Li, L. Chen, A study on database of modular façade retrofitting building envelope, *Energy Build.* 214 (2020) 109826, <https://doi.org/10.1016/j.enbuild.2020.109826>.
- [4] Z. Wang, W. Pan, Z. Zhang, High-rise modular buildings with innovative precast concrete shear walls as a lateral force resisting system, *Structures*. 26 (2020) 39–53, <https://doi.org/10.1016/j.istruc.2020.04.006>.
- [5] B. Li, S. Han, Y. Wang, et al., Feasibility assessment of the carbon emissions peak in China's construction industry: factor decomposition and peak forecast, *Sci. Total Environ.* 706 (2020) 135716, <https://doi.org/10.1016/j.scitotenv.2019.135716>.
- [6] J. Ngo, B.G. Hwang, C. Zhang, Factor-based big data and predictive analytics capability assessment tool for the construction industry, *Autom. Constr.* 110 (2020) 103042, <https://doi.org/10.1016/j.autcon.2019.103042>.
- [7] David Ruthven, The Interactive Therapeutic Emergency Department (iMED): Architectural Integration of Digital Systems into the Emergency Care Environment, Clemson University, 2007. Master's dissertation, https://tigerprints.clemson.edu/all_theses/149.
- [8] J.L. Gálvez-Martos, D. Styles, H. Schoenberger, et al., Construction and demolition waste best management practice in Europe, *Resour. Conserv. Recycl.* 136 (2018) 166–178, <https://doi.org/10.1016/j.resconrec.2018.04.016>.
- [9] R. Jin, S. Gao, A. Cheshmehzangi, et al., A holistic review of off-site construction literature published between 2008 and 2018, *J. Clean. Prod.* 202 (2018) 1202–1219, <https://doi.org/10.1016/j.jclepro.2018.08.195>.
- [10] M. Amer, A. Mustafa, S. Attia, Conceptual framework for off-site roof stacking construction, *J. Build. Eng.* 26 (2019) 100873, <https://doi.org/10.1016/j.jobe.2019.100873>.
- [11] S. Deere, X. Hui, E.R. Galea, et al., An evacuation model validation data-set for high-rise construction sites, *Fire Saf. J.* 103118 (2020), <https://doi.org/10.1016/j.firesaf.2020.103118>.
- [12] S. Srisangeethanan, M.J. Hashemi, P. Rajeev, et al., Review of performance requirements for inter-module connections in multi-story modular buildings, *J. Build. Eng.* 28 (2020) 101087, <https://doi.org/10.1016/j.jobe.2019.101087>.
- [13] B. Kiss, Z. Szalay, Modular approach to multi-objective environmental optimization of buildings, *Autom. Constr.* 111 (2020) 103044, <https://doi.org/10.1016/j.autcon.2019.103044>.
- [14] D. Winkler, A. Joseph, S. Bayramzadeh, et al., Using virtual reality to compare design alternatives using subjective and objective evaluation methods, *HERD* 13 (2020) 129–144, <https://doi.org/10.1177/1937586719851266>.
- [15] R. Li, W.J.C. Verhagen, R. Curran, A systematic methodology for Prognostic and Health Management system architecture definition, *Reliab. Eng. Syst. Saf.* 193 (2020) 106598, <https://doi.org/10.1016/j.res.2019.106598>.
- [16] M.Y. Cheng, N. Chang, Radio frequency identification (RFID) integrated with building information model (BIM) for open-building life cycle information management, in: *Proceedings of the 28th ISARC*, 2011, pp. 485–490. https://www.researchgate.net/publication/285675531_Radio_frequency_identification_RFID_integrated_with_building_information_model_BIM_for_open-building_life_cycle_information_management.
- [17] P. Meadati, J. Irizarry, A.K. Akhnouk, BIM and RFID integration: a pilot study, *Adv. Integr. Construct. Educ. Res. Pract.* 5 (2010) 570–578. https://www.researchgate.net/publication/228962800_BIM_and_RFID_integration_A_pilot_study.
- [18] A. Motamedi, A. Hammad, Lifecycle management of facilities components using radio frequency identification and building information model, *J. Inform. Technol. Construct.* 14 (2009) 238–262. https://www.researchgate.net/publication/279554483_Lifecycle_management_of_facilities_components_using_radio_frequency_identification_and_building_information_model.
- [19] J.D. Goedert, P. Meadati, Integrating construction process documentation into building information modeling, *J. Constr. Eng. Manag.* 134 (2008) 509–516, [https://doi.org/10.1061/\(ASCE\)0733-9364\(2008\)134:7\(509\)](https://doi.org/10.1061/(ASCE)0733-9364(2008)134:7(509)).
- [20] W. Shi, Framework for Integration of BIM and RFID in Steel Construction, University of Florida, 2009. https://ufdcimages.ufib.ufl.edu/UF/E0/04/11/69/00001/shi_w.pdf.
- [21] H. Xie, W. Shi, R.R.A. Issa, Implementation of BIM/RFID in computer-aided design-manufacturing-installation process, in: *2010 3rd International Conference on Computer Science and Information Technology 2*, IEEE, 2010, pp. 107–111. <https://kns.cnki.net/kcms/detail/detail.aspx?FileName=IEEE201007003024&DbName=IPFD2012>.
- [22] B. Becerik-Gerber, F. Jazizadeh, N. Li, et al., Application areas and data requirements for BIM-enabled facilities management, *J. Constr. Eng. Manag.* 138 (2012) 431–442, [https://doi.org/10.1061/\(ASCE\)CO.1943-7862.0000433](https://doi.org/10.1061/(ASCE)CO.1943-7862.0000433).
- [23] A.A. Tawab, Humane considerations in architecture and the outstanding universal significance of 20 th century cultural heritage: the case of Paimio Hospital in Finland. *Landscape architecture and regional, Planning* 3 (2018) 34–42. <https://kns.cnki.net/kcms/detail/detail.aspx?FileName=IEEE201007003024&DbName=IPFD2012>.

- [24] D. Zhao, M. Arshad, N. Li, et al., Predicting soil physical and chemical properties using vis-NIR in Australian cotton areas, *Catena* 193 (2021), 104938, <https://doi.org/10.1016/j.catena.2020.104938>.
- [25] M. Amer, A. Mustafa, S. Attia, Conceptual framework for off-site roof stacking construction, *J. Build. Eng.* 26 (2019) 100873, <https://doi.org/10.1016/j.jobbe.2019.100873>.
- [26] D.X. Zhao, B.J. He, C. Johnson, et al., Social problems of green buildings: From the humanistic needs to social acceptance, *Renew. Sust. Energ. Rev.* 51 (2015) 1594–1609, <https://doi.org/10.1016/j.rser.2015.07.072>.