

Integrating the Interpersonal Theory of Suicide Into the Relations Between Cyber-Victimization and Suicidality Among Adolescents: A Short-Term Prospective Study

Journal of Interpersonal Violence
2023, Vol. 38(1-2) NP981–NP1006
© The Author(s) 2022



Article reuse guidelines:
sagepub.com/journals-permissions
DOI: 10.1177/08862605221086638
journals.sagepub.com/home/jiv



Fanchen Meng, MS^{1,*}, Xinxin Zhu, MS^{2,*} ,
Qianqian Gao, BS³, Xiang Li, PhD⁴, Jing Chen, MS⁵, and
Qieer Sa, MS⁶

Abstract

The relation between cyber-victimization and suicidality among adolescents has been well documented; however, the mechanisms underlying this association have not been well investigated. Drawing upon the interpersonal

¹Academy of Psychology and Behavior, Tianjin Normal University, Tianjin, China

²Department of Psychology, University of Edinburgh, Edinburgh, UK

³School of Psychology, South China Normal University, Guangzhou, China

⁴Department of Applied Social Sciences, The Hong Kong Polytechnic University, Hong Kong

⁵Clinical Operation Department, TenNor Therapeutics, Suzhou, China

⁶CAS Key Laboratory of Mental Health, Institute of Psychology, Beijing, China

*These two authors contributed equally to the study. They should be regarded as joint first authors.

Corresponding Author:

Xinxin Zhu, Department of Psychology, University of Edinburgh, 7 George Square, Edinburgh EH8 9YL, UK.

Email: X.Zhu-54@sms.ed.ac.uk

theory of suicide, this study aimed to examine the mediating mechanisms (i.e., thwarted belongingness and perceived burdensomeness) underlying longitudinal, bidirectional relations between cyber-victimization and suicidal ideation/attempts among adolescents and explore gender differences in the mechanisms. Participants were 497 Chinese adolescents (46.1% male; $M_{age} = 13.28$, $SD = .66$), who completed the assessment of cyber-victimization, thwarted belongingness, and perceived burdensomeness, suicidal ideation/attempts at three-time points. The time interval between each two assessments is two weeks. Results showed the reciprocal relations between cyber-victimization and thwarted belongingness/perceived burdensomeness, between thwarted belongingness and suicidal ideation/suicide attempts, and between perceived burdensomeness and suicide attempts. Longitudinal mediation analyses indicated that Time 2 thwarted belongingness mediated the relation between Time 1 cyber-victimization and Time 3 suicidal ideation/suicide attempts. Besides, the reverse pathway from Time 1 suicidal ideation to Time 3 cyber-victimization was also mediated by Time 2 thwarted belongingness, but it was only significant in females, as suggested by multiple-group analyses. According to the aforementioned results, the interpersonal theory of suicide provides a useful framework for understanding relations between cyber-victimization and suicidality. Findings suggest that intervention targeted at improving the need to belong may help reduce suicide risk and lower cyber-victimization. Anti-cyber-victimization should be integrated into suicide intervention and prevention programs, and gender differences should be taken into account in order to enhance the program's effectiveness.

Keywords

cyber-victimization, suicidal ideation and attempts, thwarted belongingness, perceived burdensomeness, short-term evaluation

Introduction

Cyber-victimization can be broadly defined as being the target of any unwanted behavior with the intent to harm, which is carried out through information and communication technologies (Corcoran et al., 2015). Cyber-victimization is common among adolescents; in some studies, the estimated prevalence rate was up to 60%, despite high heterogeneity in terms of prevalence estimates (see Brochado et al., 2017, for a review). Cyber-victimization in adolescence can yield a wide variety of adverse psychological (e.g., depression, anxiety) and behavioral (e.g., substance misuse; see Camerini et al., 2020; Nixon, 2014, for reviews), and educational outcomes (e.g., academic achievement; see, Gardella et al., 2017, for a review). All of

the above renders adolescent cyber-victimization a significant public concern.

Of greatest concern, adolescents with cyber-victimization experiences are more likely to present suicidal ideation and attempt suicide. Contemporarily, research has established that cyber-victimization is positively linked with suicidality among adolescents. For example, [John et al. \(2018\)](#) conducted a meta-analysis on the associations between cyberbullying involvement and suicidality among young people aged under 25. Results showed that cyber-victimization was related to suicidal ideation (OR = 2.57, 95% CI [1.69–3.90], based on 16 studies) and attempts (OR = 2.15, 95% CI [1.70–2.71], based on 10 studies).

In addition, a recent meta-analysis study found that higher levels of cyber-victimization were associated with an increased risk of suicidality, with effect sizes ranging from moderate to large: suicidal ideation (OR = 2.93, 95% CI [2.43, 3.54], based on 45 studies), plans (OR = 3.07, 95% CI [2.18, 4.34], based on 10 studies), and attempts (OR = 3.38, 95% [2.59, 4.41], based on 25 studies) ([Nesi et al., 2021](#)). Moreover, this study indicated a stronger association between cyber-victimization and suicidal ideation in studies using adolescent samples (OR = 3.54, 95% CI [2.98, 4.20]) than in studies using adult samples (OR = 1.69, 95% CI [1.36, 2.11]). Besides, another meta-analysis study indicated that cyber-victimization, rather than traditional victimization, was more strongly associated with suicidal ideation ([van den Bijjnden et al., 2014](#)).

Additionally, previous research has demonstrated associations between other types of cyber experiences (e.g., cyberbullying perpetration, cyberstalking) and suicidality. For example, meta-analysis research showed that cyberbullying perpetration was associated with suicidality among adolescents and adults, but with small effect sizes: suicidal ideation (OR = 1.89, 95% CI [1.54, 2.32], based on 5 studies), plans (OR = 1.87, 95% CI [1.41, 2.48], based on one study), and attempts (OR = 1.65, 95% CI [1.25, 2.18], based on 3 studies) ([Nesi et al., 2021](#)). For another example, a systematic review study showed that cyberstalking and/or cyberharassment (akin to cyberbullying) victimization was related to several negative mental health outcomes in adults, such as depression, anxiety, and suicidal ideation ([Stevens et al., 2021](#)). However, considering the prevalence of cyber-victimization in adolescence and strong associations between cyber-victimization and adolescents' suicidality (compared to other types of cyber experiences), this study focused specifically on the cyber-victimization-suicidality link in adolescence.

Collectively, the relation between cyber-victimization and suicidality has been extensively examined in adolescence. However, our understanding of the effects of cyber-victimization on the increased risk of suicide is limited. In particular, very few efforts have been made to investigate the longitudinal mechanisms underlying these relations, which are more relevant to

establishing the temporal order of events. Such efforts are crucial for helping develop effective prevention and intervention strategies to tackle the detrimental effects of cyber-victimization.

Thwarted Belongingness and Perceived Burdensomeness as Mediators

Joiner's (2005) interpersonal theory of suicide could offer an explanation for the cyber-victimization-suicidality link. According to this theory, thwarted belongingness and perceived burdensomeness, as the two proximal interpersonal risk factors, could increase the risk of suicidal ideation or a "desire for suicide." Thwarted belongingness is defined as a sense of feeling disconnection from others or the absence of reciprocally-caring relationships, and perceived burdensomeness refers to the perception that one is a burden on those around them, characterized by a sense of liability (i.e., "my death is worth more than my life to others.") and self-hate (i.e., "I hate myself," Van Orden et al., 2010).

Cyber-victimization, as a significant form of interpersonal stress, could elicit adolescent loneliness, social withdrawal (e.g., Coelho & Romão, 2018; Matthews et al., 2020), and low self-esteem (see van Geel et al., 2018, for meta-analyses), which are core components of thwarted belongingness and perceived burdensomeness. Thus, it is possible that elevated levels of perceived burdensomeness and thwarted belongingness are associated with the increased adolescents' suicide risk specifically related to cyber-victimization.

Limited empirical studies have investigated the mediating roles of thwarted belongingness and perceived burdensomeness in the association between victimization and suicidality. Due to a scarcity of studies examining the associations between different forms of cyber-victimization and suicidality, we only review cyber-victimization in its general form. Specifically, based on the cross-sectional design with a sample of American college students ($n = 348$, $M_{\text{age}} = 20.10$), Mitchell et al. (2018) found that depression and perceived burdensomeness serially mediated the relation between cyber-victimization and suicidal ideation, while thwarted belongingness was not a significant mediator. Another cross-sectional study, focusing on the connections between traditional victimization and suicidal ideation, showed that both perceived burdensomeness and thwarted belongingness were the significant mediators in an outpatient sample ($n = 267$; $M_{\text{age}} = 37.52$; Brailovskaia et al., 2019).

Additionally, a two-wave longitudinal investigation of high school ($n = 192$) and college students ($n = 142$) with a 4-month interval, separately examined perceived burdensomeness, thwarted belongingness, and hopelessness as mediators of the association between peer victimization and suicidal ideation, using a "half-longitudinal" mediation test (Roeder & Cole,

2018). Results indicated that perceived burdensomeness was the only significant mediator. To our knowledge, this study is the only one examining these mechanisms in adolescence with a longitudinal design to investigate these associations. Nevertheless, it also has notable limitations.

Specifically, the study by Roeder and Cole (2018) focused on overall victimization by calculating a combined score for traditional and cyber-victimization, while some studies have suggested that the two are different phenomena (e.g., Schultze-Krumbholz et al., 2015), albeit related. Thus, it is necessary to clarify the effects and mechanisms of traditional and cyber-victimization on adolescent suicidality, as this can also inform targeted prevention and intervention strategies for victimization occurring online and/or offline. Furthermore, this study only included two-wave data, which was insufficient to provide robust evidence on the mediation test. Additionally, although this study employed the cross-lagged panel model to evaluate these longitudinal associations, it didn't consider the opposite directional pathway from suicidality to victimization, which deserves attention as well. The possibility of the reverse pathway is discussed below.

The Reverse Pathway From Suicidality to Cyber-Victimization

Drawing from multiple sources of theory and empirical research, heightened suicidality may change the adolescents' interpersonal circumstances, or that there potentially exists a vicious feedback loop between them. Specifically, from the stress generation model perspective (Hammen, 2004; Liu & Spirito, 2019), for example, suicidality itself may pose a risk for the future occurrence of stress, especially interpersonal stress (e.g., cyber-victimization). A possible explanation is that youth suffering from suicidality are particularly likely to be vulnerable to thwarted belongingness and perceived burdensomeness, such as a sense of social disconnection and negative self-regard (Calati et al., 2019; Cha et al., 2018). These "vulnerabilities" can be a sign of easy targets for cyber aggression/bullying perpetration, which might further increase the occurrence of cyber-victimization events among adolescents (e.g., Chu et al., 2019).

Regarding empirical evidence, a few findings suggested that cyber-victimization and suicidality were reciprocally associated with each other over time (e.g., Wright, 2016). Furthermore, prior evidence demonstrated that cyber-victimization was a predictor or outcome of thwarted belongingness/perceived burdensomeness (i.e., their proxy, e.g., loneliness, low self-esteem; e.g., Chu et al., 2019; van Geel et al., 2018), as well as mutual relations between suicidality and thwarted belongingness/perceived burdensomeness (Kyron et al., 2018; Rogers & Joiner, 2019). That all breaks the traditional view that victimization and unmet interpersonal needs (i.e., perceived burdensomeness and thwarted belongingness) unidirectionally precede suicidality. Taken together, there might be bidirectional associations between these

factors, which potentially create a feedback loop, efficiently increasing suicide risk, interpersonal distress, and cyber-victimization over time.

The Importance of Short-Term Evaluation

Methodologically, most suicide risk prediction research has employed long follow-up lengths. Specifically, a recent meta-analysis has shown that almost all longitudinal studies of suicide risk have follow-up intervals extending over 5–10 years; less than 1% of all prospective studies have follow-up intervals shorter than one month (Psychological Bulletin; Franklin et al., 2017). Studies with longer time intervals may preclude us from determining if previously studied factors tell us anything about the rapidly changing nature of suicidality, especially suicidal ideation. Besides, some of the initial high-risk “signals” for suicidality may get lost in an ever-increasing cacophony of “noise” over the longer course.

Thus, empirical studies using short-term, prospective data can mark a critical step towards improving the prediction of suicidality (Glenn & Nock, 2014). Within the short-term framework, examining the mediating roles of thwarted belongingness and perceived burdensomeness was also in line with the interpersonal theory of suicide, as this theory conceptualizes both thwarted belongingness and perceived burdensomeness as dynamic cognitive-affective states (Van Orden et al., 2010).

The Current Study

This study aimed to examine the bidirectional relations between cyber-victimization, thwarted belongingness/perceived burdensomeness and suicidality in early adolescence, particularly focusing on the mediating roles of thwarted belongingness and perceived burdensomeness in these links, using a three-wave, short-term longitudinal design. The suicidality of this study, as in most studies, included suicidal ideation (i.e., thoughts or wishes to end one’s life) and suicide attempts (i.e., self-injurious behavior with at least some intent to die). Besides, we also explored gender differences in the mediating effects of thwarted belongingness/perceived burdensomeness on relations between cyber-victimization and suicidality, given that female adolescents suffering from interpersonal difficulties are more likely to contemplate suicide than their male counterparts (see Miranda-Mendizabal et al., 2019, for a review).

Building on the argument developed above, we hypothesized that cyber-victimization, thwarted belongingness/perceived burdensomeness, and suicidal ideation/attempts would predict each other over time and that prior cyber-victimization would predict later suicidal ideation/attempts through perceived burdensomeness/thwarted belongingness. Besides that, we also tested whether perceived burdensomeness/thwarted belongingness would

mediate the reverse directional pathway from suicidal ideation or attempts to cyber-victimization.

This study was conducted in a rural area of northern China (i.e., Tianjin), as detailed in the *Method* section. Prior research indicated that Chinese adolescents from rural areas were more likely to display suicidality than their urban counterparts (e.g., [Chen et al., 2018](#); [Xing et al., 2010](#)). Thus, it is important to assess the risk factors and potential mechanisms that lead to youth suicide risk in these areas. Additionally, a recent cross-sectional study using an adolescent sample from Tianjin examined the relation between offline victimization experience and suicidal ideation, as well as the mechanisms underlying this relation (e.g., psychological pain, peer support) ([Bao et al., 2020](#)). However, this study did not specify whether the participants were from urban or rural areas. Further, cyber-victimization of young people in rural China is common (e.g., [Chen & Zhu, 2021](#)). Therefore, additional studies, particularly longitudinal studies using adolescent samples from rural areas, will be required to rigorously examine the association between cyber-victimization and suicidality, as well as the mechanisms underlying this relation.

Method

Participants

Participants included 497 students (46.1% male; age ranged 12-15; $M_{age} = 13.28$, $SD = .66$) from a middle school located in the rural area in northern China. These students are from families with low levels of income (i.e., per capita annual income is less than 10,000 yuan¹) and their parents have low education levels (i.e., about 97% without a college education, see [Table 1](#) for details). This study was conducted in November and December of 2019, and students participated in assessments at three-time points over one month, with a two-week assessment interval. Each follow-up was completed with high participation rates (i.e., Time 2, 93.16%; Time 3, 90.54%). The Missing Completely at Random (MCAR) test ([Little, 1988](#)) was conducted for all variables. This analysis of the three waves of longitudinal data suggested a normed χ^2 (χ^2/df) of 1.37, which indicated that the pattern of missing data was not materially different from a random pattern. Full Information Maximum Likelihood (FIML) analysis was applied for model estimations. In total, 497 cases were included in the analysis.

This study was conducted after obtaining approval from the Human Research Committee of Tianjin Normal University, informed consent from parents, and assent from the students. A packet of self-report instruments was administered to all students in a regular classroom environment by a trained graduate assistant. On all three occasions, the participants received identical

Table 1. Sample Characteristics of Early Adolescents From Tianjin, China ($n = 497$).

Characteristics	Proportion or M (SD)
Age (mean)	13.28 (.66)
Gender	
Male	229 (46.1%)
Female	268 (53.9%)
Paternal education	
Primary school or less	64 (12.9%)
Junior middle school	282 (56.7%)
Senior middle school	137 (27.6%)
College degree	7 (1.4%)
Master degree	7 (1.4%)
Maternal education	
Primary school or less	107 (21.5%)
Junior middle school	251 (50.5%)
Senior middle school	123 (24.7%)
College degree	11 (2.2%)
Master degree	5 (1.0%)
Ethnicity	
Han-Chinese	497 (100%)

verbal and written instructions. They were also informed of the nature of the study and the confidentiality of their responses. Participants took as much time as needed to complete the questionnaires, with the understanding that they could withdraw at any time.

Measures

Cyber-Victimization. Cyber-victimization was measured by the Chinese version of the cyber-victimization subscale of the Cyberbullying Inventory (Zhou et al., 2013). This subscale comprises 18 items (e.g., “Someone spread rumors about me online”) rated on a 4-point scale, ranging from 1 (never) to 4 (more than five times), with higher scores reflecting more frequent experiences of cyber-victimization in the past two weeks. Previous studies have shown support for its reliability and validity with Chinese adolescents (Chu et al., 2018; Zhou et al., 2013). In this study, Cronbach α s were .86 at T1, .90 at T2, and .91 at T3.

Thwarted Belongingness and Perceived Burdensomeness. Thwarted belongingness and perceived burdensomeness were both measured with the Chinese version of the Interpersonal Needs Questionnaire (X.-M. Li et al., 2015; Van Orden et al., 2012). The thwarted belongingness subscale consists of nine

items (e.g., “I feel disconnected from other people.”), and perceived burdensomeness subscale consists of six items (e.g., “I think I am a burden on society.”). Response options reflected a 7-point scale ranging from 1 (Not at all true for me) to 7 (Very true for me), with higher scores indicating greater feelings of thwarted belongingness and perceived burdensomeness in the past two weeks. The INQ has good reliability in Chinese adolescent samples (Kang et al., 2019). In the present study, Cronbach α s were .73 at T1, .81 at T2, and .83 at T3 for thwarted belongingness; Cronbach α s were .86, .88, and .92 for perceived burdensomeness at T1, T2, and T3, respectively.

Suicidal Ideation and Attempts. Suicidal ideation and suicide attempts were both measured using the Chinese version of the Columbia-Suicide Severity Rating Scale (Posner et al., 2011; Zhou et al., 2013). Suicidal ideation was assessed by the severity subscale, which consisted of five yes/no questions (e.g., “during the past two weeks, a wish to be dead, thoughts of killing self.”). This scale is scored from 0 to 5 according to the most severe suicidal ideation endorsed. Suicide attempts were evaluated by using the three yes/no items (e.g., “During the past two weeks, have you made a suicide attempt?”), which are used to assess actual suicide attempts in C-SSRS. The C-SSRS has been validated for use with clinical and school adolescent populations and has demonstrated strong psychometric properties (Núñez et al., 2019; Posner et al., 2011; Zhou et al., 2013). In the present study, Cronbach α s were 0.76 at T1, 0.79 at T2, and 0.83 at T3 for suicidal ideation; Cronbach α s were 0.68, 0.71, and 0.80 for suicide attempts at T1, T2, and T3, respectively.

Statistical Analysis

Four autoregressive cross-lagged panel models² were performed in Mplus 8.0 to test bidirectional relations between cyber-victimization, thwarted belongingness, and suicidal ideation (Model 1), between cyber-victimization, thwarted belongingness, and suicide attempts (Model 2), between cyber-victimization, perceived burdensomeness, and suicidal ideation (Model 3), as well as between cyber-victimization, perceived burdensomeness, and suicide attempts (Model 4). Autoregressive, within-time, and cross-lagged paths were modeled to provide a detailed picture of the above variables’ links while taking previous and concurrent levels of all variables into account. In all models, gender and age were included as covariates.

In the next step, we tested for indirect effects of T2 thwarted belongingness/perceived burdensomeness on the link between T1 cyber-victimization and T3 suicidal ideation/attempts, as well as the reverse pathway: From T1 suicidal ideation/attempts to T3 cyber-victimization. To achieve this, second-order cross-lagged effects (i.e., from T1 cyber-victimization to T3 suicidality, and from T1 suicidality to T3 cyber-victimization) were then included in Models

1-4. Mediation effects were examined by the bootstrapping procedure (1000 times), providing 95% confidence intervals. Indirect effects are considered significant if the 95% confidence intervals do not contain zero (Preacher & Hayes, 2008).

To further explore whether the mediating effects of thwarted belongingness and perceived burdensomeness on the cyber-victimization-suicidality links differ across gender, multi-group analyses were conducted to formally compare male and female models by constraining corresponding cross-lagged pathways involved in mediating tests to be equal between genders.

The weighted least squares means and variance adjusted (WLSMV) estimation procedure was employed to take into account the inclusion of categorical variables in our models (Li, 2016). Goodness of fit was judged by standard parameters: (a) Comparative Fit Index (CFI) ≥ 0.95 , (b) Tucker-Lewis Index (TLI) ≥ 0.95 , and (c) root mean square error of approximation (RMSEA) ≤ 0.08 (Hu & Bentler, 1999). Mplus provides an alternative chi-squared difference test (DIFFTEST) appropriate for WLSMV estimation, which was conducted for gender comparison.

Results

Descriptive Statistics

The means, standard deviations, and bivariate correlations of cyber-victimization, thwarted belongingness, perceived burdensomeness, and suicidal ideation/attempts are presented in Table 2. Almost all variables were positively correlated with each other within and across time.

Cross-Lagged Analyses

After controlling for age and gender, the fit indices of the four cross-lagged models are shown in Table 3. These models displayed adequate fit. For sake of conciseness, within-time associations, covariates, and non-significant estimates were not displayed in Figures 1, 2, 3, and 4.

Model 1 and Model 2. Results of Model 1 (Figure 1) and Model 2 (Figure 2) both showed that cyber-victimization at T1 positively predicted thwarted belongingness at T2, and thwarted belongingness at T2 was positively related to the cyber-victimization at T3. Moreover, thwarted belongingness at T1 and T2 predicted greater suicidal ideation/attempts at T2 and T3, respectively. Besides, suicidal ideation/attempts at T1 were also positively associated with thwarted belongingness at T2. Additionally, after controlling for the effects of

Table 2. Descriptive statistics and *correlations among study variables (n=497).

	Mean	SD	T1 CV	T2 CV	T3 CV	T1 TB	T2 TB	T3 TB	T1 PB	T2 PB	T3 PB	T1 SA	T2 SA	T3 SA	T1 SS	T2 SS	T3 SS
T1 CV	19.96	3.84	—														
T2 CV	19.48	3.66	.53***	—													
T3 CV	19.51	5.18	.21***	.31***	—												
T1 TB	23.84	9.03	.15***	.14**	.13**	—											
T2 TB	25.67	1.73	.17**	.20***	.24***	.50***	—										
T3 TB	28.42	11.72	.14**	.18***	.38***	.38***	.54***	—									
T1 PB	14.54	7.85	.22***	.22***	.10**	.60***	.46***	.34***	—								
T2 PB	14.76	8.33	.14***	.19***	.13**	.47***	.52***	.36***	.61***	—							
T3 PB	14.33	8.71	.20***	.11*	.18**	.29***	.40***	.39***	.46***	.59***	—						
T1 SA	.28	.67	.23***	.25***	.20**	.29***	.23**	.25***	.40***	.34***	.32***	—					
T2 SA	.30	.71	.15*	.29***	.22***	.37***	.41***	.28***	.43***	.42***	.24***	.68***	—				
T3 SA	.22	.66	.16**	.15*	.26***	.34***	.44***	.34***	.26***	.38***	.32***	.47***	.72***	—			
T1 SI	.58	1.11	.15***	.16***	.13*	.31***	.31***	.26***	.44***	.40***	.33***	.63***	.50***	.63***	—		
T2 SI	.69	1.25	.11*	.16**	.16**	.30***	.26***	.17**	.35***	.38***	.30***	.49***	.76***	.66***	.70***	—	
T3 SI	.59	1.23	.09†	.10†	.23***	.32***	.33***	.22***	.22***	.33***	.32***	.33***	.58***	.86***	.52***	.73***	—

Note. CV=Cyber-victimization; TB=Thwarted Belongingness; PB=Perceived Burdensomeness; SI=Suicidal Ideation; SA=Suicide Attempts. The *correlations were estimated by WLSMV. †p<.1; *p<.05; **p<.01; ***p<.001.

Table 3. Fit Indices for the cross-lagged panel models ($n = 497$).

Model Fit	CFI	TLI	RMSEA	[90% CI]
M1	1.000	1.002	.000	[.000, .035]
M2	.996	.991	.020	[.000, .045]
M3	.999	.998	.010	[.000, .040]
M4	.989	.971	.034	[.007, .056]

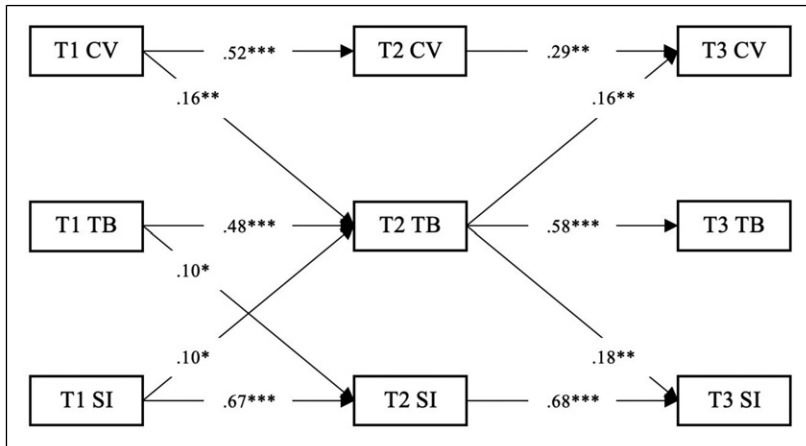
**Figure 1.** Relations between cyber-victimization, thwarted belongingness, and suicidal ideation in Chinese early adolescents ($n = 497$). CV = Cyber-victimization; TB = Thwarted Belongingness; SI = Suicidal Ideation. * $p < .05$; ** $p < .01$; *** $p < .001$.

thwarted belongingness, T1 suicide attempts were positively related to T2 cyber-victimization.

Model 3 and Model 4. Results of Model 3 (Figure 3) showed a positive effect of T1 perceived burdensomeness on T2 cyber-victimization, but this effect was marginally statistically significant ($p = .088$). Besides, T1 suicidal ideation was positively associated with T2 perceived burdensomeness. There were no other significant cross-lagged paths in Model 3. Concerning Model 4 (Figure 4), there was a positive effect of T1 cyber-victimization on T2 perceived burdensomeness, and of T1 perceived burdensomeness on T2 suicide attempts. And the positive effect of T1 suicide attempts on T2 perceived burdensomeness was also significant. Additionally, after controlling for the effects of perceived burdensomeness, suicide attempts at T1 and T2 positively predicted cyber-victimization at T2 and T3, respectively, but this cross-lagged effect from T1 to T2 was marginally significant ($p = .073$).

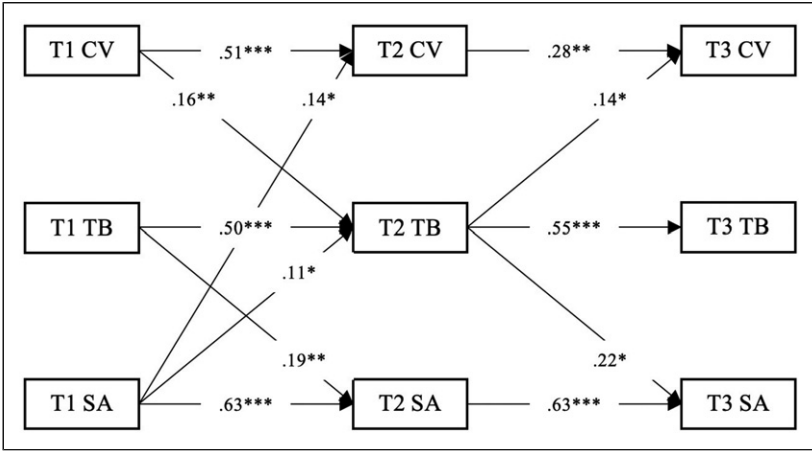

Figure 2. Relations between cyber-victimization, thwarted belongingness, and suicide attempts in Chinese early adolescents ($n = 497$). CV=Cyber-victimization; TB = Thwarted Belongingness; SA=Suicide Attempts. * $p < .05$; ** $p < .01$; *** $p < .001$.

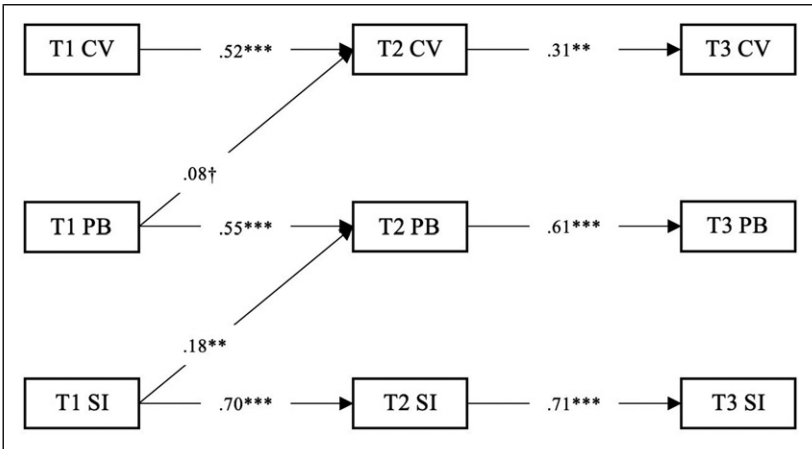

Figure 3. Relations between cyber-victimization, perceived burdensomeness, and suicidal ideation in Chinese early adolescents ($n = 497$). CV = Cyber-victimization; PB = Perceived Burdensomeness; SI=Suicidal Ideation. † $p < .1$; * $p < .05$; ** $p < .01$; *** $p < .001$.

Mediation Analyses

The bootstrap procedure indicated that the pathway from T1 cyber-victimization to T3 suicidal ideation via T2 thwarted belongingness was significant ($\beta = .02$, 95% CI [.002, .041]). And T2 thwarted belongingness

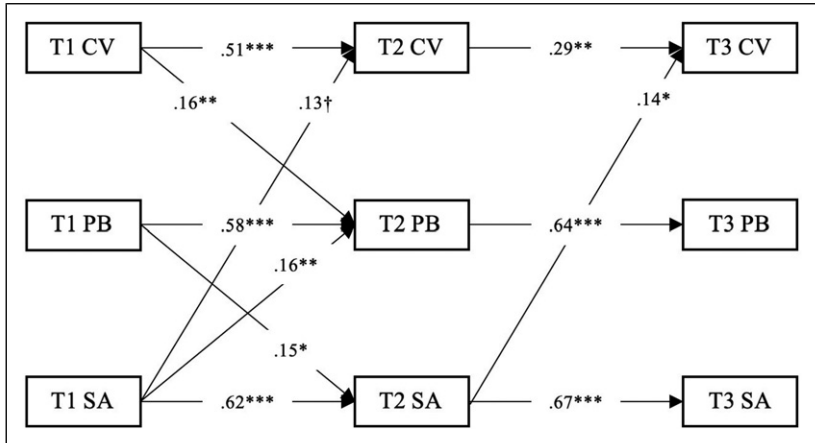

Figure 4. Relations between cyber-victimization, perceived burdensomeness, and suicide attempts in Chinese early adolescents ($n = 497$). CV = Cyber-victimization; PB = Perceived Burdensomeness; SA=Suicide Attempts. † $p < .1$; * $p < .05$; ** $p < .01$; *** $p < .001$.

also significantly mediated the effect of T1 cyber-victimization on T3 suicide attempts, but the statistical significance level was marginal ($\beta = .02$, 95% CI [.000, .050]; 90% CI [.002, .042]). Besides, the pathway from T1 suicidal ideation to T3 cyber-victimization via T2 thwarted belongingness was also significant ($\beta = .03$, 95% CI [.004, .061]). Contrary to the hypothesis, T2 perceived burdensomeness did not significantly mediate the effect of T1 cyber-victimization on T3 suicidal ideation/attempts.

Gender Differences

The results of multiple group comparison tests suggested that gender moderate the mediation effect of T2 thwarted belongingness on the relation between T1 suicidal ideation and T3 cyber-victimization ($\Delta\chi^2_{\text{WLSMV}}(2) = 13.313$, $p < .01$). Specifically, T2 thwarted belongingness significantly mediated the effect of T1 suicidal ideation on T3 cyber-victimization among females ($\beta = .06$, 95% CI [.015, .104]) rather than males ($\beta = .00$, 95% CI [-.012, .024]).

Discussion

In this study, we used relatively fine-grained (i.e., two weeks) assessment to examine reciprocal relations between cyber-victimization, thwarted belongingness, perceived burdensomeness, and suicidality, and theoretically-

informed the mechanisms underlying these associations. There are several key findings, which are discussed below.

The Reciprocal Relation Between Cyber-Victimization and Unmet Interpersonal Needs

Our results showed cyber-victimization and thwarted belongingness/perceived burdensomeness were reciprocally related over time. These findings corroborated prior evidence focusing on the unidirectional pathways from cyber-victimization to proxies for perceived burdensomeness and thwarted belongingness (e.g., loneliness, low self-esteem; e.g., [Coelho & Romão, 2018](#); [Cole et al., 2016](#)). Besides, previous studies also investigated bidirectional relations between cyber-victimization and the aforementioned proxies. For instance, recent research conducting a three-wave panel study with 6-month intervals among Chinese adolescents found that cyber-victimization was not a risk factor, but a negative outcome of adolescent loneliness and low self-esteem ([Chu et al., 2019](#)). Besides, a study using three annual measurements also indicated a unidirectional relation whereby loneliness was associated with later online victimization among adolescents from the Netherlands ([van den Eijnden et al., 2014](#)). However, the observed reciprocal effect in this study is somehow inconsistent with the above-mentioned unidirectional findings. One possible reason is that only examining indicators of thwarted belongingness and perceived burdensomeness cannot represent the full picture of them, as they also include other components such as the absence of reciprocal care and self-blame.

It should be noted that the pathways from cyber-victimization to perceived burdensomeness and from perceived burdensomeness to cyber-victimization were not consistently supported by our models with different outcomes (i.e., suicidal ideation and attempts), and some of the significant effects of cyber-victimization on thwarted belongingness/perceived burdensomeness (and vice versa) were inconsistent over time. Thus, further studies with larger samples are needed to replicate our results.

The Reciprocal Association Between Unmet Interpersonal Needs and Suicidality

Moreover, our results showed mutual relations between thwarted belongingness and suicidal ideation/attempts and between perceived burdensomeness and suicide attempts. These findings were in line with previous studies on adults at high risk for suicide using short-term follow-ups (e.g., days, [Kyron et al., 2018](#); [Rogers & Joiner, 2019](#)), as well as the interpersonal theory of suicide. However, currently, the existing evidence regarding relations between perceived burdensomeness/thwarted belongingness and suicidality is not as

strong among adolescents as it is among adults (see [Stewart et al., 2017](#), for a review). The reasons may be varied. For example, relatively few studies have directly investigated this theory among adolescents compared to adults; the limitations of previous studies, such as cross-sectional design, using proxy measures (e.g., self-esteem) rather than those that might capture the broader latent constructs (see [Stewart et al., 2017](#), for a review). Thus, more studies employing validated measures of thwarted belongingness and perceived burdensomeness and longitudinal design are needed to examine the interpersonal theory of suicide in adolescence and to further determine to what extent and how this theory operates differently in adolescence compared to adulthood.

The Mediation Role of Thwarted Belongingness

Results of longitudinal mediation analyses suggested T2 thwarted belongingness mediated the association between T1 cyber-victimization and T3 suicidal ideation/attempts, which corroborated the previous cross-sectional finding on adults ([Brailovskaia et al., 2019](#)). However, this finding was inconsistent with two prior findings supporting the mediation role of perceived burdensomeness rather than thwarted belongingness in the cyber-victimization-suicidality links in adulthood and late adolescence ([Mitchell et al., 2018](#); [Roeder & Cole, 2018](#)). This discrepancy may be that the current study mainly focused on early adolescence, and the need to belong might play a particularly significant role in this developmental period when the need for interpersonal affiliation and intimacy with peers intensifies ([Buhrmester, 1990](#)). It may also be due to the limitations of these two previous studies; for example, [Mitchell et al. \(2018\)](#) used a cross-sectional design, and [Roeder and Cole \(2018\)](#)'s study conducted a sub-optimal design (a half longitudinal design).

Additionally, the finding of thwarted belongingness as a mediator in the victimization-suicidality link was also in accordance with the theoretical background of the interpersonal theory of suicide, demonstrating cyber-victimization can be detrimental to interpersonal connectedness, which is critical to suicidal ideation and attempts. More importantly, our finding might imply that interpersonal difficulties could cascade into suicidality via threatened belonging over a short time interval (i.e., two weeks).

On the other hand, this study also indicated that T1 suicidal ideation positively predicted T3 cyber-victimization through T2 thwarted belongingness, which implies that suicidal ideation can threaten adolescent belongingness needs and then lead to the occurrence of interpersonal stressors. Some previous findings also suggested suicidal ideation can confer the risk of eliciting cyber-victimization events (e.g., [Wright, 2016](#)), but a lack of studies explored the mechanisms underlying this association. Our finding implies that the interpersonal theory of

suicide might be a useful theoretical framework to explain why the occurrence of cyber-victimization events is associated with suicidal ideation.

Notably, the current results did not support the notion that thwarted belongingness or perceived burdensomeness mediates the effect of suicide attempts on subsequent cyber-victimization. However, after controlling for thwarted belongingness/perceived burdensomeness, we found direct effects of suicide attempts on later cyber-victimization, which might indicate that suicide attempts severe enough can produce a directly detrimental effect on cyber-victimization. Future studies are thus needed to investigate the mechanisms underlying the effects of suicide attempts on cyber-victimization.

Gender Differences

Gender difference tests indicated that, in females, T2 thwarted belongingness significantly mediated the effect of T1 suicidal ideation on T3 cyber-victimization, which was not found in males. Previous studies have also investigated gender differences in relations between cyber-victimization and suicidality (e.g., Kim et al., 2019) and between thwarted belongingness/perceived burdensomeness and suicidality (e.g., Christensen et al., 2013). However, studies testing gender differences in these longitudinal mediation effects are scarce. Our finding can be supported by prior evidence indicating that females may be more sensitive to interpersonal circumstances and place more importance on social connectedness than males (Cross & Madson, 1997; Timmers et al., 1998), which, therefore, may be more detrimental to relevant outcomes for females when they perceive threatened interpersonal connectedness. From this perspective, it makes sense that satisfying the need for belongingness (e.g., building strong, supportive, interpersonal networks) is more protective for females than males.

Limitations and Future Directions

The limitations of this study bear noting. First, the current study only included adolescents from one school in rural areas, and they came from more disadvantaged family backgrounds (i.e., low-income families and parents with less education); thus, results may not generalize to other adolescent populations. Future research will be required to examine these relations among larger, more diverse samples. Second, although this study employed a relatively short-term design to examine mechanisms underlying cyber-victimization-suicidality links, future studies utilizing more frequent assessment schedules (e.g., daily, hours) to examine real-time suicidality and these relations can yield nuanced information that is critical to advancing suicide prevention efforts.

Finally, considering that standard cross-lagged panel models focus on relative change in the constructs, that is, when adolescents have frequently experienced cyber-victimization (relative to others), they would experience a subsequent rank-order increase in suicidality compared to adolescents who have experienced less/no victimization. Thus, future research should employ statistical techniques (e.g., random intercept cross-lagged panel model; this model failed to converge in the current sample) that can model within-person effects (e.g., when an adolescent has been more frequently exposed to victimization than usual, he/she would experience a subsequent increase in suicidality) in order to determine whether the current findings can be repeated at the within-person level.

In terms of future directions, future studies, including other constructs involved in the interpersonal theory of suicide (i.e., acquired capability for suicide and hopelessness), would advance our understanding of the complex processes underlying the victimization-suicidality links. Moreover, considering that cyber-victimization can take on a variety of forms (e.g., direct hostility, intrusiveness, sexual, and exclusion), future research examining the associations between different forms of cyber-victimization and suicidality will provide a more complete knowledge of these associations. Additionally, future research should consider factors that may act as protective factors (i.e., resilience) in the associations between cyber-victimization and suicidality, and the findings from such research could be used to guide suicide prevention and intervention programs.

It is worth noting that, as previously discussed, the current study's findings have limited generalizability. Our findings, however, might generalize to adolescents living in a variety of rural areas throughout China, where the majority of adolescents confront similar difficulties. For example, parents do not provide adequate guidance or monitoring of their children's Internet use (due to parents' low education levels or unavailability to supervise their children due to the need to work at another place far from home). This may result in these adolescents overusing the Internet or being exposed to a potentially harmful Internet environment, particularly now that adolescents in rural regions have easy access to the Internet. Thus, greater attention should be paid to the links between cyber-victimization or other Internet-related concerns and mental health problems in adolescents from disadvantaged families or rural areas.

Moreover, it is uncertain to what extent the results of our study can be generalized to other cultures. However, a recent meta-analysis examined the moderating role of culture (e.g., collectivism vs. individualism) in the effects of victimization (including cyber-victimization) on mental health issues (i.e., depression and anxiety) in children and adolescence and found no cultural differences in this effect in China and Europe, but did observe cultural

differences between China and North America (Yuchang et al., 2019). Therefore, future research should replicate the current findings in other countries.

Implications

Despite these limitations, this study can provide insights into understanding the bidirectional relations between cyber-victimization and thwarted belongingness/perceived burdensomeness, and can theoretically inform the mechanisms linking cyber-victimization and suicidality. The study's findings have important policy and practice implications.

Specifically, the present findings suggest that interpersonal needs proposed by the interpersonal theory of suicide, particularly thwarted belongingness, could be an important intervention target for not only reducing adolescent suicide risk but also decreasing the risk of online victimization. More importantly, our findings did support the mediation pathway, that is, cyber victimization → thwarted belongingness → suicidality occurring within a brief interval (two weeks), which may imply that thwarted belongingness can be screened/monitored as a proximal risk marker for those exposed to victimization in a brief period of time (two weeks or less), allowing for timely support and reducing their risk of suicide.

The existing literature has proposed several strategies for intervening in thwarted belongingness. For example, psychotherapy, such as brief computerized interventions (i.e., psychoeducation and cognitive bias modification), has been shown to be effective in treating thwarted belongingness and, in turn, lowering the risk of suicide (Short et al., 2019). Additionally, prior research has suggested several easily implemented strategies for improving thwarted belongingness, such as engagement in extracurricular activities and training mindfulness (Bauer et al., 2018; Collins et al., 2016), which may represent promising directions for adolescent suicide risk interventions, particularly when used in school-based suicide risk intervention programs.

Besides, given that cyber-victimization and suicidality were directly or indirectly predicted to each other, researchers and practitioners with expertise in improving young people's cyber experiences should collaborate with those working in youth suicide prevention, which will help develop programs that address cyber-victimization and suicide effectively. Moreover, this study suggests females might benefit more when screening and interventions focus on increasing the sense of belongingness to reduce the risk of cyber-victimization.

Conclusions

This study examined how the theoretical constructs of thwarted belongingness and perceived burdensomeness prospectively linked to cyber-victimization and suicidality among adolescents, using a longitudinal research design with brief intervals and relatively rigorous statistical analysis. Our examination might provide a foundation on which to extend a theoretical model of suicide that can advance our understanding of the relations between cyber-victimization and suicidality. Findings suggest that the interpersonal theory of suicide provides a useful framework for understanding relations between cyber-victimization and suicidality. Practically, efforts to increasing the need for belongingness may be more beneficial in addressing adolescent suicide risk and cyber-victimization, especially for female youth. This study also highlights the importance of short-term prospective design in suicide risk prediction research, which could provide crucial information for improving suicide risk detection.

Declaration of Conflicting Interests

The author(s) declared no potential conflicts of interest with respect to the research, authorship, and/or publication of this article.

Funding

The author(s) received no financial support for the research, authorship, and/or publication of this article

ORCID iD

Xinxin Zhu  <https://orcid.org/0000-0001-6229-5615>

Notes

1. In 2019, the annual per capita disposable income of rural households in China was 16,021 yuan, the per capita disposable income of urban households was 42,359 yuan (National Bureau of Statistics of China, 2020).
2. We also employed random intercept cross-lagged panel models to test hypothesized mediation models at the within-person level. However, such a model failed to converge.

References

- Bao, J., Li, H., Song, W., & Jiang, S. (2020). Being bullied, psychological pain and suicidal ideation among Chinese adolescents: A moderated mediation model. *Children and Youth Services Review, 109*, 104744. <https://doi.org/10.1016/j.childyouth.2020.104744>

- Bauer, B. W., Capron, D. W., Ward-Ciesielski, E., Gustafsson, H. C., & Doyle, C. (2018). Extracurricular activities are associated with lower suicidality through decreased thwarted belongingness in young adults. *Archives of Suicide Research, 22*(4), 665–678. <https://doi.org/10.1080/13811118.2018.1427162>
- Brailovskaia, J., Ujma, M., Friedrich, S., & Teismann, T. (2019). Thwarted belongingness and perceived burdensomeness mediate the association between bullying and suicide ideation. *Crisis, 41*(2), 136–140. <https://doi.org/10.1027/0227-5910/a000596>
- Brochado, S., Soares, S., & Fraga, S. (2017). A scoping review on studies of cyberbullying prevalence among adolescents. *Trauma, Violence, & Abuse, 18*(5), 523–531. <https://doi.org/10.1177/1524838016641668>
- Buhrmester, D. (1990). Intimacy of friendship, interpersonal competence, and adjustment during preadolescence and adolescence. *Child Development, 61*(4), 1101–1111. <https://doi.org/10.1111/j.1467-8624.1990.tb02844.x>
- Calati, R., Ferrari, C., Brittner, M., Oasi, O., Olié, E., Carvalho, A. F., & Courtet, P. (2019). Suicidal thoughts and behaviors and social isolation: A narrative review of the literature. *Journal of Affective Disorders, 245*, 653–667. <https://doi.org/10.1016/j.jad.2018.11.022>
- Camerini, A.-L., Marciano, L., Carrara, A., & Schulz, P. J. (2020). Cyberbullying perpetration and victimization among children and adolescents: A systematic review of longitudinal studies. *Telematics and Informatics, 49*, 101362. <https://doi.org/10.1016/j.tele.2020.101362>
- Cha, C. B., Franz, P. J., Guzmán, E. M., Glenn, C. R., Kleiman, E. M., & Nock, M. K. (2018). Annual research review: Suicide among youth—epidemiology, (potential) etiology, and treatment. *Journal of Child Psychology and Psychiatry, 59*(4), 460–482. <https://doi.org/10.1111/jcpp.12831>
- Chen, R., An, J., & Ou, J. (2018). Suicidal behaviour among children and adolescents in China. *The Lancet Child & Adolescent Health, 2*(8), 551–553. [https://doi.org/10.1016/S2352-4642\(18\)30170-6](https://doi.org/10.1016/S2352-4642(18)30170-6)
- Chen, Q., & Zhu, Y. (2021). *Cyberbullying victimisation among adolescents in China: Coping strategies and the role of self-compassion*. Health & Social Care in the Community.
- Christensen, H., Batterham, P. J., Soubelet, A., & Mackinnon, A. J. (2013). A test of the Interpersonal Theory of Suicide in a large community-based cohort. *Journal of Affective Disorders, 144*(3), 225–234. <https://doi.org/10.1016/j.jad.2012.07.002>
- Chu, X. W., Fan, C. Y., Lian, S. L., & Zhou, Z. K. (2019). Does bullying victimization really influence adolescents' psychosocial problems? A three-wave longitudinal study in China. *Journal of Affective Disorders, 246*(September 2018), 603–610. doi: [10.1016/j.jad.2018.12.103](https://doi.org/10.1016/j.jad.2018.12.103). <https://doi.org/10.1016/j.jad.2018.12.103>
- Chu, X. W., Fan, C. Y., Liu, Q. Q., & Zhou, Z. K. (2018). Cyberbullying victimization and symptoms of depression and anxiety among Chinese adolescents: Examining hopelessness as a mediator and self-compassion as a moderator. *Computers in Human Behavior, 86*, 377–386. <https://doi.org/10.1016/j.chb.2018.04.039>

- Coelho, V. A., & Romão, A. M. (2018). The relation between social anxiety, social withdrawal and (cyber)bullying roles: A multilevel analysis. *Computers in Human Behavior*, 86, 218–226. <https://doi.org/10.1016/j.chb.2018.04.048>
- Cole, D. A., Zerkowicz, R. L., Nick, E., Martin, N. C., Roeder, K. M., Sinclair-McBride, K., & Spinelli, T. (2016). Longitudinal and incremental relation of cybervictimization to negative self-cognitions and depressive symptoms in young adolescents. *Journal of Abnormal Child Psychology*, 44(7), 1321–1332. <https://doi.org/10.1007/s10802-015-0123-7>
- Collins, K. R., Best, I., Stritzke, W. G., & Page, A. C. (2016). Mindfulness and zest for life buffer the negative effects of experimentally-induced perceived burdensomeness and thwarted belongingness: Implications for theories of suicide. *Journal of Abnormal Psychology*, 125(5), 704–714. <https://doi.org/10.1037/abn0000167>
- Corcoran, L., Guckin, C. M., & Prentice, G. (2015). Cyberbullying or cyber aggression?: A review of existing definitions of cyber-based peer-to-peer aggression. *Societies*, 5(2), 245–255. <https://doi.org/10.3390/soc5020245>
- Cross, S. E., & Madson, L. (1997). Models of the self: Self-construals and gender. *Psychological Bulletin*, 122(1), 5–37. <https://doi.org/10.1037/0033-2909.122.1.5>
- Franklin, J. C., Ribeiro, J. D., Fox, K. R., Bentley, K. H., Kleiman, E. M., Huang, X., Musacchio, K. M., Jaroszewski, A. C., Chang, B. P., & Nock, M. K. (2017). Risk factors for suicidal thoughts and behaviors: A meta-analysis of 50 years of research. *Psychological Bulletin*, 143(2), 187–232. <https://doi.org/10.1037/bul0000084>
- Gardella, J. H., Fisher, B. W., & Teurbe-Tolon, A. R. (2017). A systematic review and meta-analysis of cyber-victimization and educational outcomes for adolescents. *Review of Educational Research*, 87(2), 283–308. <https://doi.org/10.3102/0034654316689136>
- Glenn, C. R., & Nock, M. K. (2014). Improving the short-term prediction of suicidal behavior. *American Journal of Preventive Medicine*, 47(3 Suppl 2), S176–S180. <https://doi.org/10.1016/j.amepre.2014.06.004>
- Hammen, C. (2004). Stress and depression. *Annual Review of Clinical Psychology*, 1(1), 293–319. <https://doi.org/10.1146/annurev.clinpsy.1.102803.143938>
- Hu, L. T., & Bentler, P. M. (1999). Cutoff criteria for fit indexes in covariance structure analysis: Conventional criteria versus new alternatives. *Structural Equation Modeling*, 6(1), 1–55. <https://doi.org/10.1080/10705519909540118>
- John, A., Glendenning, A. C., Marchant, A., Montgomery, P., Stewart, A., Wood, S., Lloyd, K., & Hawton, K. (2018). Self-harm, suicidal behaviours, and cyberbullying in children and young people: systematic review. *Journal of Medical Internet Research*, 20(4), Article e129. <https://doi.org/10.2196/jmir.9044>
- Joiner, T. (2005). *Why people die by suicide*. Harvard University Press.
- Kang, N., You, J., Huang, J., Ren, Y., Lin, M. P., & Xu, S. (2019). Understanding the pathways from depression to suicidal risk from the perspective of the

- interpersonal–Psychological theory of suicide. *Suicide and Life-Threatening Behavior*, 49(3), 684–694. <https://doi.org/10.1111/sltb.12455>
- Kim, S., Kimber, M., Boyle, M. H., & Georgiades, K. (2019). Sex differences in the association between cyberbullying victimization and mental health, substance use, and suicidal ideation in adolescents. *The Canadian Journal of Psychiatry*, 64(2), 126–135. <https://doi.org/10.1177/0706743718777397>
- Kyron, M. J., Hooke, G. R., & Page, A. C. (2018). Daily assessment of interpersonal factors to predict suicidal ideation and non-suicidal self-injury in psychiatric inpatients. *Journal of Consulting and Clinical Psychology*, 86(6), 556–567. <https://doi.org/10.1037/ccp0000305>
- Li, C. H. (2016). Confirmatory factor analysis with ordinal data: Comparing robust maximum likelihood and diagonally weighted least squares. *Behavior Research Methods*, 48(3), 936–949. <https://doi.org/10.3758/s13428-015-0619-7>
- Li, X.-M., Tie-Gang, X., Jing, Y., Li-Xia, L. V, Tao, J.-Y., & Liu, Y. (2015). Validity and reliability of the Interpersonal Needs Questionnaire in Chinese college students. *Chinese Journal of Clinical Psychology*, 23(4), 635–648. <https://doi.org/10.16128/j.cnki.1005-3611.2015.04.005>
- Little, R. J. A. (1988). A test of missing completely at random for multivariate data with missing values. *Journal of the American Statistical Association*, 83(404), 1198–1202. <https://doi.org/10.1080/01621459.1988.10478722>
- Liu, R. T., & Spirito, A. (2019). Suicidal behavior and stress generation in adolescents. *Clinical Psychological Science*, 7(3), 488–501. <https://doi.org/10.1177/2167702618810227>
- Matthews, T., Caspi, A., Danese, A., Fisher, H. L., Moffitt, T. E., & Arseneault, L. (2020). *A longitudinal twin study of victimization and loneliness from childhood to young adulthood*. Development and Psychopathology Cambridge University Press. <https://doi.org/10.1017/S0954579420001005>
- Miranda-Mendizabal, A., Castellví, P., Parés-Badell, O., Alayo, I., Almenara, J., Alonso, I., Blasco, M. J., Cebria, A., Gabilondo, A., Gili, M., Lagares, C., Piqueras, J. A., Rodríguez-Jiménez, T., Rodríguez-Marín, J., Roca, M., Soto-Sanz, V., Vilagut, G., & Alonso, J. (2019). Gender differences in suicidal behavior in adolescents and young adults: Systematic review and meta-analysis of longitudinal studies. *International Journal of Public Health*, 64(2), 265–283. <https://doi.org/10.1007/s00038-018-1196-1>
- Mitchell, S. M., Seegan, P. L., Roush, J. F., Brown, S. L., Sustaíta, M. A., & Cukrowicz, K. C. (2018). Retrospective cyberbullying and suicide ideation: The mediating roles of depressive symptoms, perceived burdensomeness, and thwarted belongingness. *Journal of Interpersonal Violence*, 33(16), 2602–2620. <https://doi.org/10.1177/0886260516628291>
- National Bureau of Statistics of China. (2020). *Households' Income and Consumption Expenditure in 2019 [Press release]*. Retrieved from http://www.stats.gov.cn/english/PressRelease/202001/t20200119_1723719.html

- Nesi, J., Burke, T. A., Bettis, A. H., Kudinova, A. Y., Thompson, E. C., MacPherson, H. A., Fox, K. A., Lawrence, H. R., Thomas, S. A., Wolff, J. C., Altemus, M. K., Soriano, S., & Liu, R. T. (2021). Social media use and self-injurious thoughts and behaviors: A systematic review and meta-analysis. *Clinical Psychology Review, 87*, 102038. <https://doi.org/10.1016/j.cpr.2021.102038>
- Nixon, C. L. (2014). Current perspectives: The impact of cyberbullying on adolescent health. *Adolescent Health, Medicine and Therapeutics, 5*, 143–158. <https://doi.org/10.2147/AHMT.S36456>
- Núñez, D., Arias, V., Méndez-Bustos, P., & Fresno, A. (2019). Is a brief self-report version of the Columbia severity scale useful for screening suicidal ideation in Chilean adolescents? *Comprehensive Psychiatry, 88*, 39–48. <https://doi.org/10.1016/j.comppsy.2018.11.002>
- Posner, K., Brown, G. K., Stanley, B., Brent, D. A., Yershova, K. V., Oquendo, M. A., Currier, G. W., Melvin, G. A., Greenhill, L., Shen, S., & Mann, J. J. (2011). The Columbia-suicide severity rating scale: Initial validity and internal consistency findings from three multisite studies with adolescents and adults. *American Journal of Psychiatry, 168*(12), 1266–1277. <https://doi.org/10.1176/appi.ajp.2011.10111704>
- Preacher, K. J., & Hayes, A. F. (2008). Asymptotic and resampling strategies for assessing and comparing indirect effects in multiple mediator models. *Behavior Research Methods, 40*(3), 879–891. <https://doi.org/10.3758/BRM.40.3.879>
- Roeder, K. M., & Cole, D. A. (2018). Prospective relation between peer victimization and suicidal ideation: Potential cognitive mediators. *Cognitive Therapy and Research, 42*(6), 769–781. <https://doi.org/10.1007/s10608-018-9939-0>
- Rogers, M. L., & Joiner, T. E. (2019). Exploring the temporal dynamics of the interpersonal theory of suicide constructs: A dynamic systems modeling approach. *Journal of Consulting and Clinical Psychology, 87*(1), 56–66. <https://doi.org/10.1037/ccp0000373>
- Schultze-Krumbholz, A., Göbel, K., Scheithauer, H., Brighi, A., Guarini, A., Tsohatzoudis, H., Barkoukis, V., Pyżalski, J., Plichta, P., Del Rey, R., Casas, J. A., Thompson, F., & Smith, P. K. (2015). A comparison of classification approaches for cyberbullying and traditional bullying using data from six European countries. *Journal of School Violence, 14*(1), 47–65. <https://doi.org/10.1080/15388220.2014.961067>
- Short, N. A., Stentz, L., Raines, A. M., Boffa, J. W., & Schmidt, N. B. (2019). Intervening on thwarted belongingness and perceived burdensomeness to reduce suicidality among veterans: Subanalyses from a randomized controlled trial. *Behavior Therapy, 50*(5), 886–897. <https://doi.org/10.1016/j.beth.2019.01.004>
- Stevens, F., Nurse, J. R. C., & Arief, B. (2021). Cyber stalking, cyber harassment, and adult mental health: A systematic review. *Cyberpsychology, Behavior, and Social Networking, 24*(6), 367–376. <https://doi.org/10.1089/cyber.2020.0253>
- Stewart, S. M., Eaddy, M., Horton, S. E., Hughes, J., & Kennard, B. (2017). The validity of the Interpersonal Theory of Suicide in adolescence: a review. *Journal*

- of *Clinical Child & Adolescent Psychology*, 46(3), 437–449. <https://doi.org/10.1080/15374416.2015.1020542>
- Timmers, M., Fischer, A. H., & Manstead, A. S. R. (1998). Gender differences in motives for regulating emotions. *Personality and Social Psychology Bulletin*, 24(9), 974–985. <https://doi.org/10.1177/0146167298249005>
- van den Eijnden, R., Vermulst, A., van Rooij, A. J., Scholte, R., & van de Mheen, D. (2014). The bidirectional relationships between online victimization and psychosocial problems in adolescents: A comparison with real-life victimization. *Journal of Youth and Adolescence*, 43(5), 790–802. <https://doi.org/10.1007/s10964-013-0003-9>
- van Geel, M., Goemans, A., Zwaanswijk, W., Gini, G., & Vedder, P. (2018). Does peer victimization predict low self-esteem, or does low self-esteem predict peer victimization? Meta-analyses on longitudinal studies. *Developmental Review*, 49, 31–40. <https://doi.org/10.1016/j.dr.2018.07.001>
- Van Orden, K. A., Cukrowicz, K. C., Witte, T. K., & Joiner, T. E. (2012). Thwarted belongingness and perceived burdensomeness: Construct validity and psychometric properties of the Interpersonal Needs Questionnaire. *Psychological Assessment*, 24(1), 197–215. <https://doi.org/10.1037/a0025358>
- Van Orden, K. A., Witte, T. K., Cukrowicz, K. C., Braithwaite, S. R., Selby, E. A., & Joiner, T. E. Jr. (2010). The interpersonal theory of suicide. *Psychological Review*, 117(2), 575–600. <https://doi.org/10.1037/a0018697>
- Wright, M. F. (2016). Cyber victimization on college campuses: Longitudinal associations with suicidal ideation, depression, and anxiety. *Criminal Justice Review*, 41(2), 190–203. <https://doi.org/10.1177/0734016816634785>
- Xing, X. Y., Tao, F. B., Wan, Y. H., Xing, C., Qi, X. Y., Hao, J. H., Su, P. Y., Pan, H. F., & Huang, L. (2010). Family factors associated with suicide attempts among Chinese adolescent students: A national cross-sectional survey. *Journal of Adolescent Health*, 46(6), 592–599. <https://doi.org/10.1016/j.jadohealth.2009.12.006>
- Yuchang, J., Junyi, L., Junxiu, A., Jing, W., & Mingcheng, H. (2019). The differential victimization associated with depression and anxiety in cross-cultural perspective: A meta-analysis. *Trauma, Violence, & Abuse*, 20(4), 560–573. <https://doi.org/10.1177/1524838017726426>
- Zhou, Z., Tang, H., Tian, Y., Wei, H., Zhang, F., & Morrison, C. M. (2013). Cyberbullying and its risk factors among Chinese high school students. *School Psychology International*, 34(6), 630–647. <https://doi.org/10.1177/0143034313479692>

Author Biographies

Fanchen Meng, is a Master student at Tianjin Normal University. Her primary research interests include adolescent peer victimization and mental health.

Xinxin Zhu, is a PhD student at the University of Edinburgh. Her primary research interests include investigating the risk factors of suicidality and self-injury among young people from the developmental perspective.

Qianqian Gao, is a Master student in School of Psychology, South China Normal University. Her research interests include adolescent suicide, non-suicidal self-injury, and bullying.

Xiang Li, PhD, is a research assistant professor at the Hong Kong Polytechnic University. Her primary research interests include aggression and delinquency, child and adolescent development, psychometric assessment, and service leadership.

Jing Chen, is a clinical researcher at clinical operation department, TenNor Therapeutics, China. She is interested in how negative emotion affects the psychological and physical healthy among people of all ages.

Qieer Sa, is a Master student at CAS Key Laboratory of Mental Health, Institute of Psychology. Her primary research interests include adolescent mobile phone addiction and mental health.