

Measuring polyp size using a virtual scale endoscope: a video tutorial with clinical case demonstration



Accurate real-time endoscopic assessment of colorectal polyp size plays a key role for selecting adequate post-polypectomy surveillance intervals or when choosing appropriate polypectomy techniques [1]. While visual estimation is the most commonly used method of measurement, there is marked interobserver variability. Biopsy forceps and ruler snares can be used as references for polyp size estimation, but are limited by being external devices that lengthen the duration of the endoscopy and increase the procedural cost [2, 3].

The virtual scale endoscope (VSE; Fujifilm, Tokyo, Japan) (► **Fig. 1**) is a new endoscope developed to provide real-time polyp size measurement during colonoscopy [4, 5]. The VSE is equipped with a red laser beam that projects a laser dot onto the mucosa. This dot changes position according to the distance between the tip of the endoscope and the target polyp (► **Fig. 1**; ► **Video 1**). The laser dot must be positioned on the left center edge of the polyp. The software then detects the position of the laser dot through its reflection on the mucosa and displays the virtual scale on the right side (► **Fig. 2**; ► **Video 1**). Best size estimation is obtained when the endoscope is positioned in front of the polyp. A distance of 4–30 mm between the endoscope and the target lesion must be maintained for accurate estimation of polyp size (► **Fig. 2**; ► **Video 1**). One recent study has evaluated the feasibility of the VSE in an ex vivo experiment and a second ex vivo study has demonstrated that size measurement is more accurate when using the VSE compared with visual size estimation [4, 5].

We present a visually assisted instruction guide on how to use the VSE and demonstrate its application in ex vivo and in vivo examples (► **Video 1**). The video tutorial discusses the most important considerations to achieve optimal polyp size measurements when using the VSE.

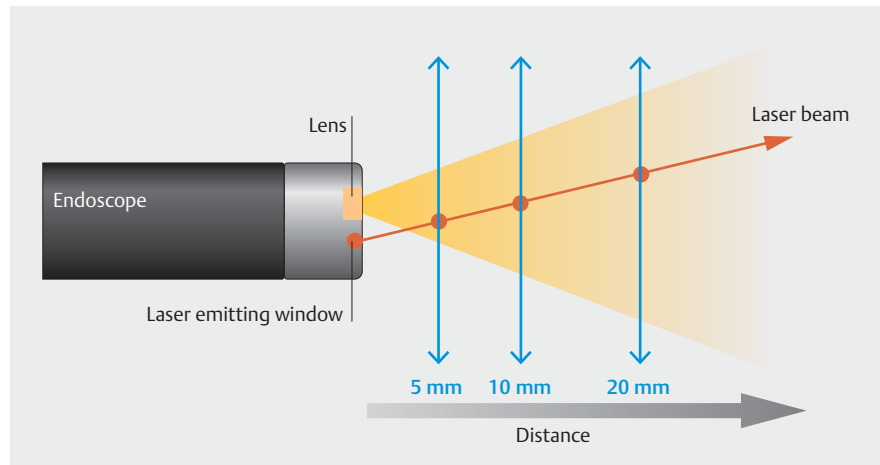

► **Fig. 1** A visual representation of polyp size estimation using the distance between the endoscope tip and the polyp.



► **Video 1** Video tutorial on the use of the virtual scale endoscope including an ex vivo demonstration and its use in a clinical setting for two colorectal polyps.

Endoscopy_UCTN_Code_CCL_1AD_2AB

The authors

Competing interests

Research funding from Fujifilm.

Melissa Zarandi-Nowroozi¹, Daniel von Renteln²

- 1 Division of Internal Medicine, University of Montreal Hospital Center, Montreal, Quebec, Canada
- 2 Division of Gastroenterology, University of Montreal Hospital Center, Montreal, Quebec, Canada

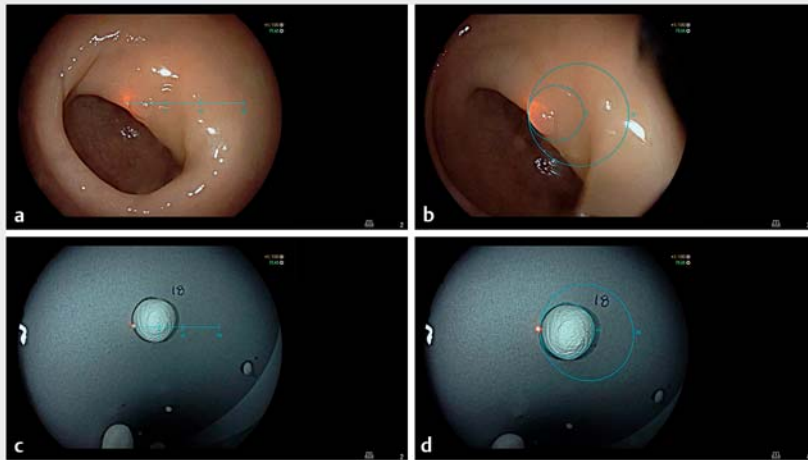

► **Fig. 2** Examples of polyp size estimation with the virtual scale endoscope for: **a** a small in vivo polyp using the linear scale; **b** a small in vivo polyp using the circular scale; **c** a large ex vivo polyp using the linear scale; **d** a large ex vivo polyp using the circular scale.

Corresponding author

Daniel von Renteln, MD

Division of Gastroenterology, Department of Medicine, University of Montreal Hospital Center, University of Montreal, 1051 Sanguinet Street, Montreal, Quebec, H2X 3E4, Canada
danielrenteln@gmail.com

References

- [1] Lieberman DA, Rex DK, Winawer S] et al. Guidelines for colonoscopy surveillance after screening and polypectomy: a consensus update by the US Multi-Society Task Force on Colorectal Cancer. *Gastroenterology* 2012; 143: 844–857
- [2] Jin HY, Qiang L. Use of disposable graduated biopsy forceps improves accuracy of polyp size measurements during endoscopy. *World J Gastroenterol* 2015; 21: 623–628
- [3] Kaz AM, Anwar A, Robinson O’Neill D et al. Use of a novel polyp “ruler snare” improves estimation of colon polyp size. *Gastrointest Endosc* 2016; 83: 812–816
- [4] Yoshioka M, Sakaguchi Y, Utsunomiya D et al. Virtual scale function of gastrointestinal endoscopy for accurate polyp size estimation in real-time: A preliminary study. *J Biomed Optics* 2021; 26: 96002
- [5] Shimoda R, Akutagawa T, Tomonaga M et al. Estimating colorectal polyp size with a virtual scale endoscope and visual estimation during colonoscopy: Prospective, preliminary comparison of accuracy. *Dig Endosc* 2022. doi:10.1111/den.14351

Bibliography

Endoscopy 2023; 55: E145–E146

DOI 10.1055/a-1956-1714

ISSN 0013-726X

published online 28.10.2022

© 2022. The Author(s).

This is an open access article published by Thieme under the terms of the Creative Commons Attribution-NonDerivative-NonCommercial License, permitting copying and reproduction so long as the original work is given appropriate credit. Contents may not be used for commercial purposes, or adapted, remixed, transformed or built upon. (<https://creativecommons.org/licenses/by-nc-nd/4.0/>)

Georg Thieme Verlag KG, Rüdigerstraße 14, 70469 Stuttgart, Germany



ENDOSCOPY E-VIDEOS

<https://eref.thieme.de/e-videos>



Endoscopy E-Videos is an open access online section, reporting on interesting cases and new techniques in gastroenterological endoscopy. All papers include a high quality video and all contributions are freely accessible online. Processing charges apply (currently EUR 375), discounts and waivers acc. to HINARI are available.

This section has its own submission website at <https://mc.manuscriptcentral.com/e-videos>