

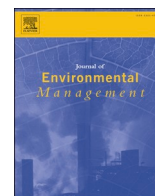

Since January 2020 Elsevier has created a COVID-19 resource centre with free information in English and Mandarin on the novel coronavirus COVID-19. The COVID-19 resource centre is hosted on Elsevier Connect, the company's public news and information website.

Elsevier hereby grants permission to make all its COVID-19-related research that is available on the COVID-19 resource centre - including this research content - immediately available in PubMed Central and other publicly funded repositories, such as the WHO COVID database with rights for unrestricted research re-use and analyses in any form or by any means with acknowledgement of the original source. These permissions are granted for free by Elsevier for as long as the COVID-19 resource centre remains active.



## Research article

# A selectivity index for public-private partnership projects in the urban water and sanitation sector in Latin America and the caribbean

Jaime Munoz-Jofre<sup>a,\*</sup>, Sergio Hinojosa<sup>b</sup>, Anne-Laure Mascle-Allemand<sup>b</sup>, Javier Temprano<sup>a</sup>

<sup>a</sup> Departamento de Ciencias y Tecnicas Del Agua y Del Medio Ambiente. University of Cantabria, Av. Los Castros Sn, Santander, 39005, Cantabria, Spain

<sup>b</sup> PIAPPEM Institute, 4201 Cathedral Av. Ap 418E, NW, Washington DC, 20016, USA



## ARTICLE INFO

## Keywords:

Public-private partnership  
Water supply  
Sanitation  
Public utilities  
Critical success factors

## ABSTRACT

The rapid urban development, the Agenda 2030, the climate change adaptation and the COVID 19 crisis highlight the need to increase investment in public infrastructure and improve water supply and sanitation services. For this, an alternative to traditional public procurement is the participation of the private sector under the public-private partnership (PPP) model. The objective of this article is to develop a tool based on critical success factors (CSFs) that allows for evaluation during early stages of the convenience of developing a PPP project for W&S in urban areas of Latin America and the Caribbean. The index was developed based on literature review (779 variables), review of cases (20 variables) and expert opinion to assign them an estimated value of importance. The results were analysed by exploratory and confirmatory factor analysis, selecting 17 main variables grouped into 6 CSFs, the most relevant of which are Convenience, Certainty, Leadership, Attraction, Performance and Reliability. The application of this index allows an early assessment of the feasibility of a PPP project and/or the selection of the alternatives with the best chances of success. On the other hand, this study contributes to the international discussion on the most relevant elements related to the success of PPP in W&S projects.

## 1. Introduction

There are important reasons to accelerate the creation and improvement of water and sanitation (W&S) infrastructures and services in Latin America and the Caribbean (LAC), such as the fulfillment of international commitments (2030 Agenda), the increase in population and the migration of people to urban areas (in LAC the rate of urbanization reached 80.7% in 2018, and could reach 87.8% by 2050 (UNICEF-OMS, 2021), the need to protect the people's health (WHO, 2020), and the impact of crises such as COVID-19 on water consumption and quality (Bhowmick et al., 2020; Butler et al., 2020.; Kalbusch et al., 2020).

In the LAC region, W&S services require significant investments for the creation and improvement of infrastructure. According to 2020 data, the region has an urban coverage of 81% in safely managed supply, and 40% in safely managed sanitation (UNICEF-OMS, 2021). In addition, the

region has evident differences in the level of development of each country, particularly in their economic, legal, technological, social and environmental frameworks, which implies a wide variety of problems and potential solutions. For these and other reasons, it is important to consider different management alternatives, including the public-private partnership (PPP) model as participation of the private sector. The World Bank (2017) defines the PPP as 'a long-term contract between a private party and a government entity, for the provision of a public good or service, in which the private party assumes significant risk and management responsibility, and remuneration is linked to performance'. According to Brichetti et al. (2021) in LAC, to achieve Sustainable Development Goal No. 6 by 2030, the water and sanitation sector requires US\$373.9 billion in total investments, 68% of which is for building new infrastructure and 32% for maintenance and replacement of assets. On the other hand, private financing of public infrastructure has been increasing in recent decades, however the return on

**Glossary:** CBA, cost-benefit analysis; CFA, confirmatory factor analysis; CFI, comparative fit index; COVID 19, corona virus disease 2019; CSF, critical success factor; EFA, exploratory factor analysis; KMO, Kaiser-Meyer Olkin; LAC, Latin America and the Caribbean; PCA, principal component analysis; PPP, public-private partnership; RMSEA, root mean square error of approximation; SI, selectivity index; SRMR, standardized root mean-square; TLI, Tucker-Lewis index; TVE, total variance explained; UN, United Nations; W&S, water and sanitation; WoS, Web of Science.

\* Corresponding author.

E-mail address: [jmj883@alumnos.unican.es](mailto:jmj883@alumnos.unican.es) (J. Munoz-Jofre).

<https://doi.org/10.1016/j.jenvman.2023.117564>

Received 24 February 2022; Received in revised form 15 February 2023; Accepted 20 February 2023

Available online 4 March 2023

0301-4797/© 2023 The Authors. Published by Elsevier Ltd. This is an open access article under the CC BY-NC-ND license (<http://creativecommons.org/licenses/by-nc-nd/4.0/>).

these investments is not always guaranteed, and can lead to bigger problems such as conflicts, termination of contracts or rescue of private operators (Demirel et al., 2022), therefore the selection of projects is important and must be supported by appropriate methodologies. The selection of PPP projects is a process that consumes time and public resources (Grimsey and Lewis, 2004; Osei-Kyei and Chan, 2019; Tharmakulasingham and Pasindu, 2021) in which it is necessary to improve the transparency, efficiency and effectiveness of evaluation and procurement procedures (Dithebe et al., 2019), identifying and managing risks, especially those that may significantly impact public budgets, lead to contract renegotiation or project failure (Carbonara and Pellegrino, 2018; Jiang, 2016). Regarding this, Latin America and the Caribbean is not an isolated case and needs improvements in its procedures for preparing and procuring PPPs (World Bank, 2018).

This article offers a tool to identify water and sanitation projects that can be implemented by PPPs with the best chances of success, based on the identification and evaluation of criteria based mainly on critical success factors (CSFs). In general, we understand that CSFs are events or circumstances, internal or external, relevant to the management team because of their importance to the project (Ferguson and Dickinson, 1982). There are multiple studies that identify CSFs in different types of projects such as energy (Xu et al., 2015; Zhao et al., 2010), construction contracts (Ergönül, 2017; Jha and Iyer, 2006), sports infrastructure (Jefferies et al., 2002), housing (Tucker et al., 2014; Youneszadeh et al., 2017) and in recent years, some authors have started to develop research focused on water infrastructure (Li et al., 2019; Meng et al., 2011; Osei-Kyei et al., 2019a).

In general, the results of other investigations include groups of similar CSFs, however in W&S the order of the factors is different, and there are factors not included in other studies. In this sense, in Ameyaw and Chan (2015b) economic, political and factors related to social behavior are obtained (corruption, water theft, non-payment of bills), while in Li et al. (2019), economic sustainability, society (related to public satisfaction), the environmental effects of the project, and the elements of infrastructure and management are more relevant. Politics-related factors are mentioned in many industry publications (Ameyaw and Chan, 2015a, 2016a; Zhang et al., 2019), as well as economic factors (Tariq et al., 2019) and legal factors (Ameyaw et al., 2017; Dithebe et al., 2019; Tariq et al., 2019; Zhang et al., 2019). It is also common to find CSFs related to project management and its risks (Meng et al., 2011; Mousavizade and Shakibazad, 2019; Swamy et al., 2018). In addition, the literature review did not find any specific publications on CSFs for W&S projects in LAC region, and the closer ones are for developing countries (Ameyaw et al., 2017; Tariq et al., 2019). Some studies (Ameyaw and Chan, 2016b; Chen et al., 2019; Osei-Kyei et al., 2020; Osei-Kyei and Chan, 2017b, 2019) have developed project selection indexes based on CSFs, but each one groups and weighs the importance of each factor differently, which obviously has an effect on the project selection process. There are different approaches and tools that can be used to select PPP projects, such as filtering by size and complexity (Thierie and De Moor, 2017), indexes based on critical success factors or risk factors (Ameyaw and Chan, 2016b; Osei-Kyei et al., 2017; Osei-Kyei and Chan, 2019), identification and mitigation of risks (Ameyaw and Chan, 2015a, 2015b, 2016a; Pellegrino, 2021), concessionaire selection (Wu and Gao, 2012; Zhang, 2004a, 2004b), value-for-money analysis (Cui et al., 2019), indexes for unsolicited proposals (Osei-Kyei et al., 2020), capital structure models and project sustainability (Chen et al., 2019; Hou et al., 2022), and conceptual framework analysis (Cherkos et al., 2020). Therefore, to improve the selection process of W&S PPP projects in LAC, it is necessary to study CSFs in depth.

The objective of this article is to develop a tool based on critical success factors that, during the early stages, allows for evaluation of the convenience of developing a PPP project for W&S in urban areas of Latin America and the Caribbean. Consequently, it is necessary to identify the variables considered in the water sector, assess them in the specific

framework of the PPP model in W&S and develop a selectivity index applicable within the scope of the study (urban areas of LAC). The LAC countries considered are Argentina, Bahamas, Barbados, Belize, Bolivia, Brazil, Chile, Colombia, Costa Rica, Dominican Republic, Ecuador, El Salvador, Guatemala, Guyana, Haiti, Honduras, Jamaica, Mexico, Nicaragua, Panama, Paraguay, Peru, Suriname, Trinidad and Tobago, Uruguay and Venezuela.

In addition, this publication is important for researchers and practitioners in sectors such as project management, governance, and investment, to improve the understanding and the selection of projects with higher chances of success, making better use of resources and accelerating the development of required services and infrastructure. It will also allow decision makers to be informed of the most relevant aspects they will have to face for the design and operation of the project.

## 2. Materials and methods

To achieve the objective, the first step is to obtain variables applicable to this type of projects, which is done through a review of cases in LAC and a review of literature. Subsequently, a valuation questionnaire is designed that allows experts in the sector to assign a value of importance to each variable. Finally, the data are processed by multivariate analysis and the parameters are obtained to elaborate a Selectivity Index (SI).

### 2.1. Review of cases

The first phase to obtain variables was carried out by analysing international reports and scientific publications on the reality of W&S services in LAC. The analysis sought to identify the most important variables that affected various urban projects according to different specialists. For the present study, 6 publications were selected and analysed, referring to cases located in Argentina, Bolivia, Colombia, Mexico, Chile and Panama (Andres et al., 2010; Bitran and Arellano, 2005; Castro, 2008; Marin, 2009; PPIAF, 2014).

The 20 most important variables for the W&S sector obtained in this review are: Increased coverage and quality of service, Controls through performance indicators, Efficiency in operational and commercial management, Adequate tariff model, Contract design, Political support for the project, Minimal political interference, Good financial conditions, Quality of available information, Adequate social management (workers and users), Transparency, Competitive bidding process, Stable regulatory framework, Good design of plans and programs, Public participation, Social acceptance of the project, Collaboration between public and private sectors, Institutional cohesion, Specialised private contribution (knowledge and technology), and Conflict resolution mechanisms.

### 2.2. Variables in literature review

The literature review is a widely used method to obtain CSFs (Ameyaw and Chan, 2015b; Cui et al., 2018; Li et al., 2019; Osei-Kyei et al., 2020). To compile it, a search was carried out for scientific articles in indexed journals in the renowned Web of Science (WoS) database, which has an extensive and up to date record of publications (see Fig. 1).

The search was conducted in December 2019 and the following Boolean searches, and word and subject filters were applied: 'infrastructure', 'water', 'private' and 'critical success factors', excluding results with conference papers and book chapters. Subsequently, a filtering of the automatic searches was carried out with 34 results, eliminating those articles that did not have a direct relationship with the subject of study (8 articles removed) and manually adding 2 articles (Mousavizade and Shakibazad, 2019; Osei-Kyei and Chan, 2017a) that have arisen from the reading of the subject and that are applicable to the proposed objective. The selection of scientific literature identified 28 articles for review and analysis (Fig. 2). However, only 11 focus all their

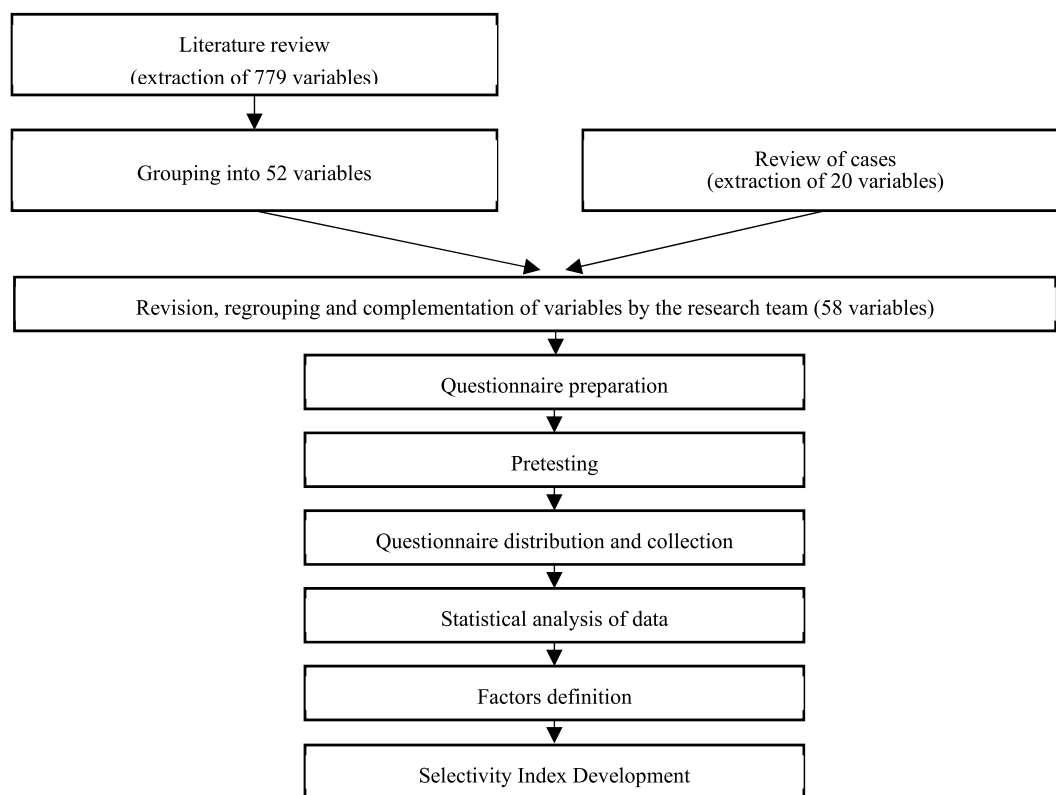

Fig. 1. Flow diagram of the research process.

attention on urban supply and/or sanitation infrastructures (Ameyaw et al., 2017; Ameyaw and Chan, 2015a, 2015b, 2016a; Dithebe et al., 2019; Li et al., 2019; Meng et al., 2011; Mousavizade and Shakibazad, 2019; Swamy et al., 2018; Tariq et al., 2019; Zhang et al., 2019).

Once the contents and characteristics of the selected articles had been analysed, 779 elements were identified, which for the purposes of this study are considered as variables. It is important to point out that these elements do not always receive the denomination of CSF since many of them were used for the construction of questionnaires without being grouped or given a value and are not always defined as factors towards achieving the success of the project (for example, the variables ‘Foreign exchange rate’ versus ‘Variation in foreign exchange rate and convertibility issues’). This was solved in the variable grouping phase by leaving all variables expressed as contributing to project success.

To analyse the 779 variables, the first step was to incorporate them into a digital list to facilitate their management and comparison. Then, the list of variables was imported into a concept mapping software (Xmind, 2020) that allows the organisation and visualization of all the variables at once. It also allows to move each of the variables to compare them by similarity one by one and create similar groups or categories (the grouping criteria were based on the experience of the research team). The initial categories, which are only an instrument to order the information, were: PPP project priority level for society and government, PPP project feasibility, PPP project characteristics, PPP project bankability, PPP project environment, and PPP value generation. In the process, 12 variables (~1.7% of the total) were left out because they were not applicable to the type of projects to be studied. The result of grouping the remaining variables was a total of 52 variables. The grouped variables were reviewed by the members of the research team to detect failures in the process.

Finally, on the list of variables from the review of cases in LAC (20 variables) and the literature review (52 variables), a new review was performed, reordering and complementing the list with variables that could be relevant to the analysis and that were not found previously. The

variables were discussed and tested with the research team through a pilot questionnaire to make them applicable to W&S projects in LAC, as has been done by other researchers (e.g. Ameyaw et al., 2017; Mousavizade and Shakibazad, 2019; Swamy et al., 2018).

### 2.3. Questionnaires and participants

To obtain the field data, surveys are usually developed and distributed (e.g. Dithebe et al., 2019; Li et al., 2019; Osei-Kyei et al., 2019c, 2017; Osei-Kyei and Chan, 2017c; Zhang, 2005a), and some authors report that they test them by means of a pilot survey or pretesting (Ameyaw and Chan, 2015a; Osei-Kyei et al., 2019a; Osei-Kyei and Chan, 2017c, 2019; Swamy et al., 2018). Other authors use methods such as semi-structured interviews (Mazher et al., 2018; Osei-Kyei and Chan, 2018), or the Delphi method for the evaluation of variables (Ameyaw and Chan, 2015a, 2016a; Cui et al., 2019; Xu et al., 2010). The pilot questionnaire was taken on February 2020.

To assess the relative importance of the variables, a structured questionnaire was developed and sent in February 2020 to 60 specialists in academia, consulting, financial institutions and public agencies. All the experts were selected for their in-depth knowledge and experience in the implementation of PPP projects and the W&S sector in Latin America and the Caribbean. These experts were asked to evaluate the degree of importance of each variable in explaining the potential performance of a PPP W&S project based on their applied experience. The assessment was conducted using a *Likert* scale with values between 1 and 5 (similar to those used in Dithebe et al., 2019; Mousavizade and Shakibazad, 2019; Osei-Kyei et al., 2020, 2019a), where 1 corresponds to ‘Not Important’ or ‘Very unimportant’, 2 to ‘Not very important’, 3 to ‘Important’, 4 to ‘Very important’ and 5 to ‘Critical or Extremely important’. The specialists responded in reference to the set of countries by direct communication (e-mail and/or telephone call), leaving a written record (paper or MS-Word digital document) or using a web form (Google Forms). Responses were received between February and May 2020. The

GROUP	VARIABLE	Ameyaw and Chan (2015b)	Ameyaw and Chan (2016a)	Ameyaw et al. (2017)	Ameyaw and Chan (2015a)	Cui et al. (2018)	Cui et al. (2019)	Ditthebe et al. (2019)	Li et al. (2019)	Mazher et al. (2018)	Meng et al. (2011)	Mousavizade and Shakibazad (2019)	Opawole et al. (2019)	Osei-Kyei and Chan (2017c)	Osei-Kyei and Chan (2017a)	Osei-Kyei and Chan (2018)	Osei-Kyei and Chan (2019)	Osei-Kyei et al. (2017)	Osei-Kyei et al. (2019a)	Osei-Kyei et al. (2019c)	Swamy et al. (2018)	Tariq et al. (2019)	Xiong et al. (2019)	Xu et al. (2010)	Yu et al. (2018a)	Yu et al. (2018b)	Zhang et al. (2019)	Zhang (2005a)	Zhang (2005b)			
Category 1	Compatibility with W&S Sectorial Strategic Planning																															
	Project positive impact on the coverage and/or continuity of the W&S service																															
	Reduction of social inequality in access to W&S services																															
	Reduction of territorial inequality in access to W&S services																															
	Project positive impact on employment																															
Category 2	Project technical complexity																															
	Project political support																															
	Level of progress of studies																															
	Information systems																															
	Stakeholders rejection of the project																															
	Rate impact																															
	Number of stakeholders																															
	Health and Environmental impact																															
	Changes to laws and/or land acquisition																															
	Project leader																															
Category 3	Project size																															
	Definition level of investment needed																															
	Public assets quality																															
	Long-term and easy to estimate demand																															
	Services and Key Performance Indicators definition																															
Category 4	Independence between projects																															
	Collection risk																															
	Tariff policy																															
	Favorable economic environment																															
	Project attractiveness for the private and financial sectors																															
	Financial cost																															
	Fiscal incentives																															
	Banks and local capital markets capacity																															
	Experience in PPP projects in the country in all sectors																															
	Experience in W&S PPP projects in comparable countries																															
Category 5	Private sector capacity for construction or service management																															
	Political commitment to PPP in W&S																															
	Political risk																															
	Social rejection to PPP																															
	Public sector experience and capacity																															
	Dedicated unit																															
	Communication and environmental education																															
	Agility of approval process, permits and authorizations																															
	Institutional cohesion																															
	Adequate legal and regulatory frameworks																															
Category 6	Mechanisms for conflict resolution and contractual modifications																															
	W&S Regulator independence																															
	Competition in the bidding process																															
	Transparency and accountability																															
	Change in laws, regulations and norms																															
	Contract flexibility																															
	Innovations and know-how of private sector																															
Unrated	Transfer and risk management																															
	Function Integration (bundling)																															
	Quality of the service																															
	Guaranteed operation and maintenance																															

Fig. 2. Applicable variables obtained through bibliographic review.

distribution by sector of the panel of experts who responded to the questionnaires is presented in Table 1.

Compared to other studies, the 37 questionnaires received are considered sufficient for the analysis. As Osei-Kyei et al. (2019b, 2019a, 2018) point out, by analysing their own results and other similar past studies, it is considered as a rule of thumb that the central limit theorem is valid for samples of not less than 30 questionnaires, and statistical analysis is possible to obtain useful results.

Table 1  
Summary of panel of experts consulted.

Sector	Number of experts	Distribution (%)
Academia/Research	4	10.8%
Consulting	17	45.9%
Financial Institution	14	37.8%
Public Sector	2	5.4%

## 2.4. Data analysis and index construction

To analyse the data and highlighting the most important variables or grouping them, techniques such as interview analysis (Osei-Kyei and Chan, 2018), authors or experts' experience (Osei-Kyei and Chan, 2017a), multi-decision-making technique AHP (Swamy et al., 2018; Yu et al., 2018b), social network analysis based on graph and network theories (Xiong et al., 2019), and mainly statistical and mathematical methods are used (Ameyaw et al., 2017; Ameyaw and Chan, 2015a, 2015b; Cui et al., 2019; Mazher et al., 2018; Opawole et al., 2019; Osei-Kyei et al., 2017, 2019a, 2019c; Osei-Kyei and Chan, 2017c, 2019; Xu et al., 2010; Zhang et al., 2019).

Data analysis was performed with multivariate statistical tools, using factor analysis (FA), which includes exploratory factor analysis (EFA) and confirmatory factor analysis (CFA). Principal component analysis (PCA) was also used. The FA methodology was chosen because it identifies the most important variables and relates them to the other variables (internal structure), assigns them a weight or importance that allows them to be ordered, and can be easily transformed into an index to meet the proposed objective. The methodology was compared with other numerical valuation methods, especially with the analytical hierarchical process (AHP), which is focused on ranking the variables by importance. The AHP has been used by other researchers to compare and assign a weight to each variable, which makes it possible to identify the most important and order them, but it is not focused on determining latent variables and requires a comparison by pairs of variables, requiring more valuations from each expert than using a *Likert* scale, lengthening the valuation phase. SPSS and Jamovi statistical software were used in this phase.

To evaluate the convenience of developing a W&S PPP project, an index was developed based on the CSFs identified. It is important to note that this tool is to be used prior to a more precise analysis or implementation stage, such as Value for Money studies, their structuring, and their preparation for a competitive selection process. The use of this index for the screening analysis should be seen as a necessary condition to check the suitability of the PPP model for a project, not as a sufficient condition (Hinojosa et al., 2020).

The construction of the index based on the selected variables involves the development of a mathematical model that represents in a simplified form the phenomenon to be understood. For this, it is important to construct a manageable model, that is, simple, objective and applicable to different cases within the field of study. Therefore, its construction implies reducing and/or grouping the 58 observed variables into a group of fewer variables, called factorial or latent variables. In this sense, the EFA makes it possible to reduce the variables while minimising the distortion that this process may cause, and facilitates the management and interpretation of the data set (Costello and Osborne, 2005; Raykov and Marcoulides, 2008). In this research, the EFA was used to group the variables that the experts have valued, generating 6 factors or latent variables that contain the most relevant elements in the process of achieving success in PPPs in the W&S sector in LAC.

## 3. Results

### 3.1. Variable extraction

First, descriptive statistics were calculated and an initial EFA was performed. The values of the sedimentation curve indicated that an extraction of 18 variables could be performed. Because the calculation of possibilities to identify the most relevant variables is too high, the PCA method was used. For this purpose, different analyses were performed by adjusting the rotation method (principal component analysis, unweighted least squares, generalised least squares, maximum likelihood, principal axis factorization, alpha and image factorization) and the

extraction method (parallel analysis, eigenvalues and number of factors). The PCA made it possible to generate twelve extraction models with the variation of extraction and rotation methods (M1 to M12). On the other hand, 4 more models were added, by means of an intuitive selection of variables to compare the results and the final groupings, which were named J1, J2, J3 and J4. All the variable ordering models obtained were compared and models M2 and M9 were eliminated because they were repeated.

The next step was to carry out a new EFA with the 14 models generated and compare their characteristics and suitability to generate a subset of final factors. Initial checks were carried out to apply the EFA on the generated models. To this end, Cronbach's Alpha, Kaiser-Meyer Olkin (KMO) and Bartlett's sphericity parameters were analysed. The recommended values for this type of study are: Cronbach's alpha >0.70, KMO >0.6, and Bartlett's sphericity <0.05 (Li et al., 2019). Through this analysis, models M6, M8 and M11 are discarded.

### 3.2. Model comparison

The next step of the analysis was to repeat the EFA with the variable clustering models. In this step, an analysis was carried out by selecting 3 variable extraction methods (minimum residual, maximum likelihood, and principal axis) and 3 factor reduction methods (parallel, eigenvalues and selection of a fixed number of factors selected by the researcher). Usually in the scientific literature, extraction of between 3 and 9 factors are observed (Ameyaw and Chan, 2015b; Dithebe et al., 2019; Mousavizade and Shakibzad, 2019). For this study, analysis using between 3 and 8 variables was performed to observe the behavior of each model. By applying the EFA, the total variance explained (TVE) corresponding to each grouping of selected variables was obtained for each model.

It was observed that the M4 model (18 variables obtained with PCA) shows the highest total variance explained regardless of the number of factors we tested, from 3 up to 8 (Fig. 3). Therefore, the M4 model was selected as the most appropriate, with a Cronbach's alpha of 0.830, a KMO of 0.603, a Bartlett's sphericity <0.001.

### 3.3. Number of factors

Before identifying the level of total variance explained, the factor groupings made by the combination of each available extraction and rotation methods were analysed for the number of factors that could be of interest (values of total variance explained between 66.1 and 76.9%). It was observed that the structure of the model with 6 factors with principal axis extraction method and varimax rotation offers a more coherent, logical and clear grouping. This ordering model offers a total variance explained, within the set of 18 variables, of 69.8%.

### 3.4. Confirmatory factor analysis (CFA)

The main interest of the CFA lies in examining the pattern of relationships between the factors amongst themselves, as well as between them and the observed variables. The use of CFA seeks to determine whether the 6 factors (or latent variables) obtained by applying the EFA in the previous stage can be explained through covariances or correlations with the 18 observed variables that they group together. By means of this technique, the observed variables are modeled as linear combinations of those 6 factors, and these in turn are associated with error expressions. The CFA provides as a result an overall confidence level to check the correspondence of the set. As its name indicates, the CFA is aimed at confirming the structure initially proposed in the EFA and uses the structural equation technique for parameter estimation, goodness-of-fit and predictions (Batista and Coenders, 2000; Bollen and Curran, 2005; Byrne, 2009; Jak, 2015).

The CFA was carried out on a sample of 337 observations generated

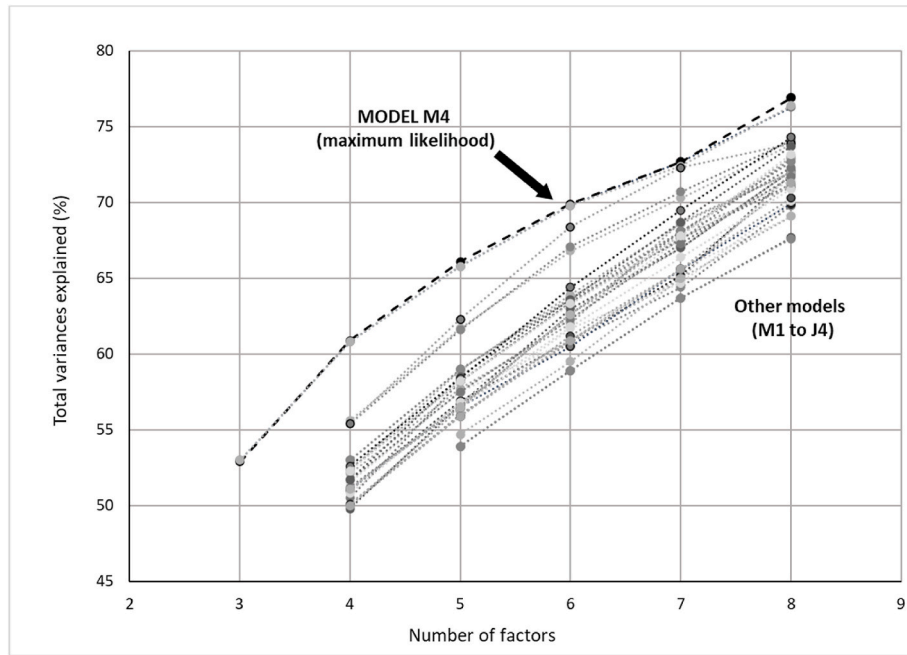

Fig. 3. Comparison of the total variance explained of M4 over the other models.

from the parametric bootstrap resampling technique (Efron, 1979), which is based on generating random samples from the observations made and taking into account that the means of each sample generated

should converge to a normal probability distribution (central limit theorem). From the initial analysis of the CFA and observing the results of the initial PCA of the 18 selected variables, it was determined that

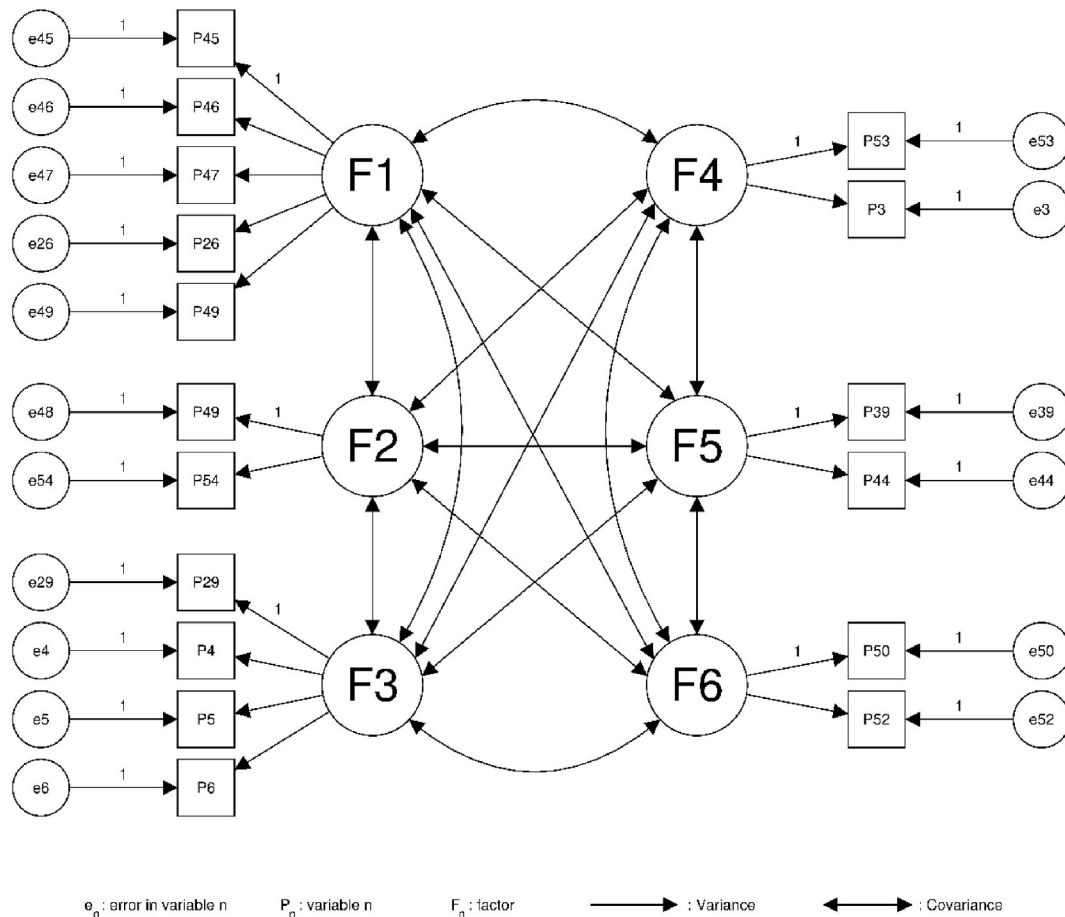

Fig. 4. Latent variables model obtained from CFA.

**Table 2**  
Coefficients of each variable.

Factor	Measured variable	Coef.	Standard error	Confidence interval (95%)		Z-Test	P
				Lower	Higher		
1. CERTAINTY	P45. Legal framework favourable to the PPP model <sup>a</sup> )	0.1095	0.0464	0.01847	0.2	2.36	0.018
	P46. Dispute resolution mechanisms and contractual modifications <sup>a</sup>	0.1456	0.0502	0.0472	0.244	2.9	0.004
	P47. Independence of the W&S sector regulator <sup>a</sup>	0.1836	0.0552	0.07547	0.292	3.33	<0.001
	P26. Enabling economic environment	0.0688	0.0516	-0.0323	0.17	1.33	0.182
2. ATTRACTION	P49. Transparency and accountability <sup>a</sup>	0.1999	0.059	0.08428	0.316	3.39	<0.001
	P48. Competition in the bidding process	0.1775	0.1203	-0.05841	0.413	1.47	0.14
3. CONVENIENCE	P54. Integration of functions (bundling)	0.2111	0.1387	-0.06065	0.483	1.52	0.128
	P29. Financial cost	0.0926	0.0593	-0.02359	0.209	1.56	0.118
	P4. Reduction of social inequality in access to W&S services <sup>a</sup>	0.2418	0.082	0.08113	0.402	2.95	0.003
	P5. Reduction of territorial inequality in access to W&S services <sup>a</sup>	0.2803	0.0889	0.106	0.455	3.15	0.002
4. PERFORMANCE	P6. Impact on employment <sup>a</sup>	0.3056	0.0739	0.16071	0.451	4.13	<0.001
	P53. Risk transfer and management <sup>a</sup>	0.2024	0.0651	0.0749	0.33	3.11	0.002
	P3. Positive impact of the project on W&S service coverage and/or continuity <sup>a</sup>	0.1708	0.0571	0.0589	0.283	2.99	0.003
5. LEADERSHIP	P39. Social rejection of the PPP model <sup>a</sup>	0.229	0.0963	0.04026	0.418	2.38	0.017
	P44. Institutional cohesion (join-up) <sup>a</sup>	0.2337	0.1047	0.02841	0.439	2.23	0.026
6. RELIABILITY	P50. Change in laws, regulations and norms <sup>a</sup>	0.1177	0.0551	0.00963	0.226	2.13	0.033
	P52. Innovations and private sector know-how <sup>a</sup>	0.1939	0.087	0.02347	0.364	2.23	0.026

<sup>a</sup> Confidence level >95%.

variable P32 (Impact on public finances) is the least important variable in the description of the original variance. The new structural model generated is shown in Fig. 4, together with the coefficients obtained in the CFA in Table 2. Therefore, considering the model's association logic and the error associated with each variable, we proceeded to reformulate the initial model with 17 variables grouped into 6 categories, obtaining better results in the set adjustment measures. Table 3 shows the estimates of the regression weights (coefficients). In general, the results obtained are considered to be within the statistically acceptable range.

The  $\chi^2$  (chi-squared) test shows a value of 94.6 ( $p = 0.734$ ) and the values obtained for the fit indices of the CFA performed are detailed in Table 3, indicating the reference level for each measure and its partial evaluation.

Therefore, regarding the fit indices obtained, it is considered that the proposed model, with 17 variables grouped into 6 factors, fits adequately.

### 3.5. Selectivity index (SI)

In general, indices are used to explain a concept or construct in terms of a group of variables. A linear and additive approach, previously used by other authors (Chen et al., 2019; Hu et al., 2016; Lam et al., 2008; Yeung et al., 2009) was used to develop the Selectivity Index, because it is easy and simple to understand due to it being based on a linear equation. To better understand the relative activity of variables, to obtain a robust linear model and to give guarantees of reliability, the coefficients of each variable are normalized (Osei-Kyei et al., 2020; Osei-Kyei and Chan, 2017b), in this case so that their sum is 100 (Table 4). The developed model is expressed as follows:

$$M = \sum_{i=1}^n a_i F_i + \epsilon \tag{1}$$

where.

M: Correlation model of variables

$$SI = (0.2236 * CERTAINTY) + (0.1228 * ATTRACTION) + (0.2909 * CONVENIENCE) + (0.1180 * PERFORMANCE) + (0.1462 * LEADERSHIP) + (0.0985 * RELIABILITY) \tag{3}$$

**Table 3**  
Confirmatory factor analysis fit indices.

Index	Value	Reference level	Evaluation ( <sup>a</sup> )
$\chi^2/df$	0.91	<3	Acceptable
CFI	1.00	>0.90	Acceptable
TLI	1.20	>0.90	Acceptable
SRMR	0.0389	<0.05	Acceptable
RMSEA	0.00	<0.05	Acceptable
RMSEA 90% lower	0.00	-	-
RMSEA 90% higher	0.0217	-	-

<sup>a</sup> Comparison values according to (Byrne, 2009).

$a_i$ : Factor loading of the factor  $F_i$   
 $F_i$ : Factor or latent variable  $i$

Based on the CFA and in order to establish the correspondences between the variables and the factors (latent variables), the following structural model of the Index is presented.

$$SI = \sum_{j=1}^n \gamma_j F_j + \epsilon \text{ therefore } F_j = \sum_{i=1}^n \zeta_{ij} x_i + U_i \tag{2}$$

where.

SI: Selectivity index  
 $\gamma_j$ : Factorial loading of factor  $F_j$ .  
 $F_j$ : Factor or latent variable  $j$  (1–6).  
 $\zeta_{ij}$ : Loading of variable  $i$  on factor  $j$ .  
 $x_i$ : Value assigned to variable  $i$  (1–17).  
 $\epsilon, U$ : Measurement error

Subsequently, with the 17 coefficients presented in Table 2, a normalization of each variable and each factor was performed to obtain the weight of each one. The results are shown in Table 4.

Thus, the SI equation is expressed as follows:



**Table 4**  
Weight of selected variables and factors.

Factor	Variable	Variable weight	Factor weight
1. CERTAINTY	P45. Legal framework favourable to the PPP model	3.46%	22.36%
	P46. Dispute resolution mechanisms and contractual modifications	4.60%	
	P47. Independence of the W&S sector regulator	5.80%	
	P26. Enabling economic environment	2.17%	
	P49. Transparency and accountability	6.33%	
2. ATTRACTION	P48. Competition in the bidding process	5.61%	12.28%
	P54. Integration of functions (bundling)	6.67%	
3. CONVENIENCE	P29. Financial cost	2.93%	29.09%
	P4. Reduction of social inequality in access to W&S services	7.64%	
	P5. Reduction of territorial inequality in access to W&S services	8.86%	
	P6. Impact on employment	9.66%	
	P53. Risk transfer and management	6.40%	
4. PERFORMANCE	P3. Positive impact of the project on W&S service coverage and/or continuity	5.40%	11.80%
5. LEADERSHIP	P39. Social rejection of the PPP model	7.24%	
	P44. Institutional cohesion (join-up)	7.39%	
	6. RELIABILITY	P50. Change in laws, regulations and norms	3.72%
P52. Innovations and private sector know-how		6.13%	

## 4. Discussion

### 4.1. Definition of factors

The factors obtained are described below. It should be noted that in each case emphasis is placed on the variables with the greatest strength, but evidently there are correlations of lesser weight present in the structure of dependencies that have been discarded to simplify the understanding and management of the set.

- Factor 1. CERTAINTY.

This factor is defined as the degree of economic and legal precision offered by the investment environment for private investors wishing to participate in a W&S project. This factor includes variables related to the way in which the specific legal norms on which a W&S PPP project must be developed are defined (laws, regulations, and other lower hierarchy norms), providing stability and clarity for the operation of the project under this model. The concept of legal certainty in the PPP model applies to both the rules and the criteria used to regulate the parties involved (public and private). It is evident that a specific, stable, and clear legal framework, as well as procedural guidelines and dedicated units for PPP type projects allow for a better understanding of the evaluation criteria, and prediction and assessment of the procedures applicable during the project cycle, especially where the public sector is accustomed to procedures for traditional public work projects. In this regard, [Ameyaw et al. \(2017\)](#) highlights the importance of enabling policies and legal frameworks for water supply PPP projects, and [Zhang et al. \(2019\)](#) describes it in the maturity of laws and regulations. It is also necessary to have mechanisms to resolve conflicts or adapt contracts to new conditions, as pointed out by [Tariq et al. \(2019\)](#) or [Dithebe et al. \(2019\)](#) within the public cooperation factor, reducing the chances of a breakdown of relations between the parties involved in a PPP contract, which could jeopardize the achievement of the objectives and goals set. Furthermore, to maintain a good relationship, both between the project stakeholders and with the society, it is necessary to ensure clear procedures, where decision making is done in an objective, open and justified manner, allowing for access to regularly generated information. In [Tariq et al. \(2019\)](#), the relevance of the lack of transparency as a risk element for this type of projects is indicated. Transparency, together with institutional independence are very relevant within legal certainty, since the regulatory body must act in accordance with previously established regulations and guidelines without arbitrarily supporting any of the parties involved. Such independence implies that the contracting party can make decisions based on sectoral objectives, which is linked to its own capabilities (resources, competences, etc.), which are

highlighted within the most relevant variables in [Ameyaw et al. \(2017\)](#), [Swamy et al. \(2018\)](#) and [Tariq et al. \(2019\)](#). The factor also includes economic certainty, which is related to a favourable economic environment (low inflation, low interest rates, low unemployment rate, low default indicators, etc.) and stable macroeconomic conditions (growth rate, strength and stability in the exchange rate, stock market, etc.), which can make private investment less interesting in periods of financial crisis or *force majeure*.

- Factor 2. ATTRACTION.

This factor is defined as the interest caused by the structuring of the project to involve a reasonable number of stakeholders so that the selection process to provide the W&S service is competitive. This factor relates the structure variables and the project selection process. To increase the chances of success, it is necessary for the project structure to be properly designed to optimize its management, with aspects such as the integration of functions and coordination of operations being fundamental, especially if this type of project is in a broader management system (integrated water cycle). These variables were also identified by different authors ([Li et al., 2019](#); [Swamy et al., 2018](#); [Zhang et al., 2019](#)). If such structuring is interesting enough to attract a considerable number of candidates, the selection process will have more alternatives to choose from and more competitiveness in terms of price, quality, innovation and expected results.

- Factor 3. CONVENIENCE.

This factor is defined as the expected social impact of the project in terms of reducing social inequalities by adequately using the project's resources. It integrates the variables that relate the cost of financing with the socioeconomic impact that a W&S project may have, seeking to reduce social inequalities in access to services (including aspects such as the adequacy of tariff and subsidy policies) and in their territorial distribution (peripheral neighbourhoods, less populated cities, decentralised territories, etc.). Regarding the cost of financing, [Zhang \(2005b\)](#) highlights financial soundness as a CSF, and in the literature review by [Yu et al. \(2018a\)](#), it is also highlighted in transnational PPP projects. However, it is important to note that [Zhang et al. \(2019\)](#) does not consider financing and operational risks as critical, as their observations in China give more importance to the financial market situation and the availability of financial instruments for decades, so that the cost of financing should be a variable to be studied in less economically stable countries. On the other hand, tariff aspects are identified as relevant factors in [Swamy et al. \(2018\)](#) and [Tariq et al. \(2019\)](#) in supply services in India ('reasonable water tariffs' and 'high tariffs'), and inequality in

service access can be found indirectly in variables such as the level of water theft, identified in Ameyaw and Chan (2016, 2015b) and Tariq et al. (2019). The factor also includes the importance of the positively impacting economic activity and employment generation that this type of project has, considering an appropriate use of available economic resources. It is understood, therefore, that the success of a W&S PPP project must have tangible benefits for society, reducing gaps in access to services and generating economic activity.

• Factor 4. PERFORMANCE.

This factor is defined as the W&S service operator’s capacity to manage resources adequately and convert them into favourable results for the parties involved (generate value). It integrates variables related to the management of W&S service risks and the expected results in terms of growth and quality, expressed in terms of coverage and continuity. The factor highlights the importance of being able to transfer to the private sector a substantial amount of the risks that it will have to manage adequately, mainly by limiting cost and time overruns. In this sense, Meng et al. (2011) identifies the importance of better management of economic aspects and reduction of the main cost overruns and delays. Also, Ameyaw et al. (2017) highlights the importance of good contract design, and generally, other authors analyse the factors under this perspective of risks and their management (Ameyaw and Chan, 2015a, 2015b, 2016a; Tariq et al., 2019; Zhang et al., 2019). Successful risk management is linked to the direct benefits expected from the service, expressed primarily on the quality and coverage of the service, which is related to engineering aspects pointed out in Li et al. (2019) or the technical performance provided by the private sector (Tariq et al., 2019).

• Factor 5. LEADERSHIP.

This factor is defined as the capacity of the public sector to manage citizen, state, and business interests in a balanced manner, in order to obtain a good performance during the development of the project. This factor includes variables such as the public acceptance of the W&S projects operating under the PPP model and the institutional cohesion between the different agencies involved throughout the duration of the project. In this sense, Ameyaw et al. (2017), Swamy et al. (2018) and Tariq et al. (2019) highlight the importance of public acceptance of the PPP model for its proper development, since the social pressure of the various interest groups that support or reject the project will end up influencing the political power, in some cases affecting the criteria with which sectoral decisions are made, with direct consequences for the development of the project. It is important that the political and technical actors in the public sector are coordinated and aligned within the framework established by the plans and programs already in place. In this sense Dithebe et al. (2019) and Meng et al. (2011) consider public cooperation and internal government coordination relevant, and political interference is highlighted in Ameyaw and Chan (2016, 2015b). To ensure smooth project development, it is necessary to provide stability and consistency in regulation and public policies in the sector, which is also highlighted in Tariq et al. (2019) and Zhang et al. (2019).

• Factor 6. RELIABILITY

This factor is defined as the level of credibility offered by each of the parties (public and private) to meet the expectations generated in a contractual relationship, particularly in regard to legal stability and good technical performance during the development of the project. From the private point of view, it is expected that there is a legal stability that allows predicting an investment scenario with lower risks in this sense, preventing sudden changes in the applicable rules. Variables related to such stability are highlighted within the most important in Ameyaw and Chan (2015a), Dithebe et al. (2019), Tariq et al. (2019)

and Zhang et al. (2019). On the other hand, the reliability of the private part is reflected in improved operational management, allowing more efficient designs, procedures and technologies to be incorporated into the project. Such added value is also highlighted in Li et al. (2019) and Mousavizade and Shakibazad (2019) and can be interpreted from the risk analysis in Ameyaw and Chan (2015a) and Tariq et al. (2019).

4.2. Index application

The SI is a tool to evaluate at an early stage the convenience of developing a project in the W&S sector through the PPP model in the Latin American and Caribbean region.

First of all, the 17 variables presented in Table 2 should be assessed, for which it is recommended to organize a workshop with sector specialists, allowing participants to speak and share their opinions about each variable freely, and reach an agreement regarding their importance. For the workshop to correctly work, some minimal elements are required: the number of participants should be small (between 8 and 12), with knowledge about the project, experience in projects assessment and evaluation, and/or have competences in the public procurements process. A moderator experienced in group management and a person in charge of the workshop’s record are strongly advised. It is also encouraged to carry out an initial presentation of the workshop and the evaluation method (SI), as well as a technical presentation for each project before its evaluation, and clearly establishing the value assignment (one by one or by vote). In addition, it is recommended to consider the distribution in the room, time schedules and the elaboration of a final report. It is recommended to use the Likert scale (between 1 and 5), assigning a value of 1 to the most unfavourable situation in a PPP project and 5 to the most favourable situation, and it is essential that all 17 factors be evaluated. The values obtained through structured questionnaires should be processed and input into the model presented. For the use of variable and factor weights, the components of the structural factor matrix and total variances have been normalized (see Table 4).

To interpret the resulting SI, an evaluation scale is proposed. The results of the assessments can be interpreted from the ranges of values that define a low, medium or high level of selectivity, presented in Table 5.

However, it is necessary to carry out a sensitivity analysis to evaluate the SI dependence on the variables, to understand the relevance that errors coming from the initial assessment or from the factorial model itself may have. This analysis is also useful to identify and pre-design measures to reduce the risks on the variable (mitigation) and on the success of the project as a whole.

4.3. Comments and findings

Initially, through a simple mean value analysis of the questionnaires, it was observed that the top-five variables included the attractiveness of the project for the private and financial sectors, the legal framework favourable to the PPP model, the political commitment to the PPP model in the W&S sector, the change in laws, regulations and norms, and

**Table 5**  
Evaluation of the selectivity index (SI).

RESULTS	SI Range	INTERPRETATION
Low	1 to 2.5	The PPP model is not recommended for the W&S project.
Medium	2.5 to 3.5	The PPP model is not recommended for the W&S project in the situation observed. However, it is suggested to analyse the feasibility of applying the mitigation measures identified during the analysis and reconsider the results of the SI.
High	3.5 to 5	The PPP model is recommended for the W&S project. It is suggested to apply the mitigation measures identified during the analysis.

transparency and accountability. However, the observable variables with more weight in the factor analysis are the impact on employment (P6), reduction of territorial inequality in access to W&S services (P5), reduction of social inequality in access to W&S services (P4), institutional cohesion (P44), and social rejection of PPPs (P39).

It should be noted that the model shown in Fig. 4 was developed based on a construct proposed by the research team. In the AFE, the number of variables (18) was obtained by PCA and their total variance explained (Fig. 3). However, in the AFC, the authors propose different hypotheses on how to group these 18 variables. The models presented in 11 investigations (Ameyaw et al., 2017; Ameyaw and Chan, 2015a, 2015b, 2016b; Dithebe et al., 2019; Li et al., 2019; Meng et al., 2011; Mousavizade and Shakibzad, 2019; Swamy et al., 2018; Tariq et al., 2019; Zhang et al., 2019) served to compare the initial construct proposed, but the conditions, the observable variables and the methods of analysis are independent in each research. On the other hand, the number of factors in the literature is between 3 and 9. However, 3 factors was considered to be too general, and 9 factors made it very difficult to understand the model. Therefore, different hypotheses were tested, obtaining the model presented in Fig. 4, which complies with the fit indices. After quantifying, testing and confirming the model the factors were named and defined, as well as compared with the results of other research.

The CSFs model has been compared with other models (Budayan, 2018; Chan et al., 2010; Liu et al., 2014; Shi et al., 2016) for generic PPP projects (water, electricity, transportation, ...), and the CSFs are similar, but not the same. An important difference is that the other models give more importance to the characteristics and conditions in which the projects are developed (economics, politics, management, ...), and little to no importance to the social impact of the project as the CSFs model presented (differences in access to the service, territorial differences, impact on employment, ...). It is therefore necessary to analyse them separately.

On the other hand, the CSFs model has also been compared with other models applied to supply and sanitation services (Ameyaw et al., 2017; Ameyaw and Chan, 2015b; Dithebe et al., 2019; Li et al., 2019; Meng et al., 2011; Swamy et al., 2018; Tariq et al., 2019; Tariq and Zhang, 2021; Zhang et al., 2019) and it has been observed that the factors are similar, but do not have the same importance, which influences the weighting to select projects. It is also observed that the proposed model gives importance to stability aspects (legal, trust between the parties, public sector leadership), which is possibly motivated by political/economic changes taking place in LAC in past years. It is also observed that the model presented gives more importance to the effects of the project on society (social and territorial inequalities, employment generation, ...), and that environmental variables are not yet given great importance, possibly because they are studied at later stages.

Risk transfer and management (P53) is a very important variable for any type of PPP project. On its own, this variable has the seventh highest weight within the set (Table 4), but the factor that contains it (Performance) is in position 5 out of 6. One would expect this variable to have a higher weight (coefficient) because it is a fundamental element in establishing the public guarantees necessary for the success of any PPP contract. However, its weight is not low and is possibly outweighed by the other variables (stability aspects and effects of the project on society) due to the need for this type of services (W&S) for the development of LAC. For this reason, it would be interesting to carry out similar research in the region to compare if the risk transfer and management variable is more relevant in countries with higher W&S coverage.

#### 4.4. Analysis limitations

A limitation to be taken into account in the use of the SI is the bias of the evaluation team. Therefore, it is very important to have specialists with extensive experience in the development of W&S projects, with

knowledge of the administrative processes of the implementation site and the operation of the PPP model, as well as the ability to analyse local characteristics, mainly corresponding to political, economic and social aspects. Likewise, to increase the degree of certainty during the process of comparing alternatives, it is necessary for the evaluation team to have reliable information at their disposal to carry out their work objectively.

One of the recurring limitations during the use of the CFA is to make an adequate proposal of the names of each set of variables, since the user could move away from the factors' definition, using their own criteria instead, or giving greater importance to variables that do not have so much weight in the set. Therefore, it is advisable to always reference the variables involved in the definition of each factor.

The reference values for the evaluation of the SI are based on the research team's experience in different PPP projects developed in LAC. However, it is necessary to consider possible adjustments to the proposed levels as know-how and dissemination of this specific type of project increases.

## 5. Conclusions

In the countries of the Latin American and Caribbean region, the development of W&S projects is very necessary to meet the Sustainable Development Goals. An alternative to accelerate the achievement of these goals is the participation of the private sector in this type of services. To facilitate project selection processes during early stages, this work has developed an analysis tool that allows evaluate the suitability of this projects with a small number of variables.

In this work, an extensive search of scientific publications and bibliographic analysis of the 28 selected references was carried out, highlighting the fact that publications of this type in the W&S sector are few and that no references were found in indexed journals for the region under study. The processes of grouping and analysing the variables potentially applicable to the study area indicate that there is a great diversity of denominations to refer to the same variables. On the other hand, the studies reviewed analyse these variables fundamentally from the perspective of success factors or risk factors.

Statistical analysis of the results, using exploratory factor analysis, principal component analysis and confirmatory factor analysis techniques, identified the 17 most relevant variables out of the initially proposed set. These variables, grouped into 6 factors, facilitated the development of a selectivity model to evaluate the potential success of the type of projects proposed.

The six factors found, ordered from highest to lowest weight within the SI, were: Convenience, Certainty, Leadership, Attraction, Performance and Reliability. Compared to other CSFs models in non-W&S projects, the 'Convenience' factor makes a relevant difference. In models related to W&S projects this factor is considered, but not with the same importance. In addition, this factor has fewer bibliographical references than the rest. Its inclusion within the selectivity index makes a difference and enriches the analysis of the potential success of this type of project, since it forces us to consider elements such as social and territorial equality, and the impact of the project on employment.

A greater weight of factors related to stability (certainty, leadership and reliability) was also observed, possibly due to regional characteristics and political/economic changes in LAC in recent decades. On the other hand, the environmental variables are not yet considered among the most important.

The selectivity index has been developed based on the multi-criteria matrix method, and weighting for each of the variables that make up the critical success factors is provided, thus making it possible to meet the initial objective of developing a tool based on these factors that allows in early stages for evaluation of the convenience of developing a PPP project for W&S in urban areas of Latin America and the Caribbean.

To use the selectivity index, it is recommended that a project selection workshop be held, in which experts in the area with sufficient capacity (experience, knowledge, objectivity and understanding of the

problem) should participate and have sufficient and reliable information to carry out their work adequately. On the other hand, the process of analysis of the variables, which includes the description, understanding and group evaluation of the critical success factors, facilitates unifying the criteria of different experts to identify and evaluate significant risks.

This research contributes to the development of knowledge of the sector by applying analytical and statistical tools based on the identification and analysis of variables found in the scientific literature and in the review of cases in Latin America and the Caribbean. On the other hand, it contributes to the governance of the sector and to the analysis for the design of public policies, and in particular to the management of W&S services in Latin America and the Caribbean through the identification of critical success factors and the development of a practical method for the evaluation of alternatives. In addition, this study contributes to the international scientific and academic discussion of the most relevant elements that contribute to the success of W&S public-private partnership projects in Latin America and the Caribbean.

### Credit author statement

Conceptualization, Methodology, Validation: Munoz-Jofre J., Hinojosa, S. and Mascle-Allemande, A.L.; Formal analysis: Munoz-Jofre J., Hinojosa, S. and Mascle-Allemande, A.L.; Investigation: Munoz-Jofre J.; Data curation: Munoz-Jofre J. and Hinojosa, S.; Writing—original draft preparation: Munoz-Jofre J.; Writing—review and editing: Hinojosa, S. and Mascle-Allemande, A.L.; Visualization: Munoz-Jofre J., Hinojosa, S., Mascle-Allemande, A.L. and Temprano J.; Supervision: Hinojosa, S., Mascle-Allemande, A.L. and Temprano J.

### Funding

This research did not receive any specific grant from funding agencies in the public, commercial, or not-for-profit sectors.

### Declaration of competing interest

The authors declare that they have no known competing financial interests or personal relationships that could have appeared to influence the work reported in this paper.

### Data availability

Data will be made available on request.

### Acknowledgments

The authors would like to thank the specialists who selflessly responded to the evaluation surveys, which allowed us to obtain relevant data for the research. We are also grateful for the comments and contributions of the PPP specialists for reviewing and improving the evaluation questionnaire (Mr. Javier Garcia and Mr. Fernando Benavente). We also thank Mr. Nicolas Espinoza for reviewing the manuscript. Finally, we thank the academic and research support staff of the University of Cantabria for facilitating access to various tools for the development of the research.

### Appendix A. Supplementary data

Supplementary data to this article can be found online at <https://doi.org/10.1016/j.jenvman.2023.117564>.

### References

- Ameyaw, E., Chan, A., 2015a. Evaluating key risk factors for PPP water projects in Ghana: a Delphi study. *J. Facil. Manag.* 13, 133. <https://doi.org/10.1108/JFM-10-2013-0051>.

- Ameyaw, E., Chan, A., 2015b. Evaluation and ranking of risk factors in public-private partnership water supply projects in developing countries using fuzzy synthetic evaluation approach. *Expert Syst. Appl.* 42, 5102–5116. <https://doi.org/10.1016/j.eswa.2015.02.041>.
- Ameyaw, E., Chan, A., 2016a. A fuzzy approach for the allocation of risks in public-private partnership water-infrastructure projects in developing countries. *J. Infrastruct. Syst.* 22, 4016016. [https://doi.org/10.1061/\(ASCE\)IS.1943-555X.0000297](https://doi.org/10.1061/(ASCE)IS.1943-555X.0000297).
- Ameyaw, E., Chan, A., 2016b. Critical success factors for public-private partnership in water supply projects. *Facilities* 34, 124–160. <https://doi.org/10.1108/F-04-2014-0034>.
- Ameyaw, E., Chan, A., Owusu-Manu, D.G.D.G., 2017. A survey of critical success factors for attracting private sector participation in water supply projects in developing countries. *J. Facil. Manag.* 15, 35–61. <https://doi.org/10.1108/JFM-06-2016-0027>.
- Andres, L.A., Sislen, D., Marin, P., 2010. Charting a New Course: Structural Reforms in Colombia's Water Supply and Sanitation Sector. World Bank, Bogota. <https://openknowledge.worldbank.org/handle/10986/27920> License: CC BY 3.0 IGO.
- Batista, J.M., Coenders, G., 2000. *Modelos De Ecuaciones Estructurales*. Arco Libros - La Muralla.
- Bhowmick, G.D., Dhar, D., Nath, D., Ghangrekar, M.M., Banerjee, R., Das, S., Chatterjee, J., 2020. Coronavirus Disease 2019 (COVID-19) Outbreak: Some Serious Consequences with Urban and Rural Water Cycle. *Npj Clean Water*. <https://doi.org/10.1038/s41545-020-0079-1>.
- Bitran, G., Arellano, P., 2005. Regulating Water Services. Sending the Right Signals to Utilities in Chile, Viewpoint. Note No. 286. March 2005). World Bank. <https://openknowledge.worldbank.org/handle/10986/11229> License: CC BY 3.0 IGO (Washington, DC).
- Bollen, K.A., Curran, P.J., 2005. *Latent Curve Models: A Structural Equation Perspective*. Wiley.
- Bricchetti, J.P., Mastronardi, L., Rivas, M.E., Serebrisky, T., Solís, B., 2021. La brecha de infraestructura en América Latina y el Caribe: estimación de las necesidades de inversión hasta 2030 para progresar hacia el cumplimiento de los Objetivos de Desarrollo Sostenible. Inter-American Development Bank. <https://doi.org/10.18235/0003759>.
- Budayan, C., 2018. Analysis of critical success factors in public private partnership projects by triangulation method: Turkey perspective Acknowledgement. *J. Fac. Archit. Gazi Univ.* 33, 1029–1044. <https://doi.org/10.17341/gazimmdf.416404>.
- Butler, G., Pilotto, R.G., Hong, Y., Mutambatsere, E., 2020. The impact of COVID-19 on the water and sanitation sector. International Finance Corporation (IFC), a member of the World Bank Group. [https://www.ifc.org/wps/wcm/connect/industry\\_ext\\_content/ifc\\_external\\_corporate\\_site/infrastructure/resources/the+impact+of+covid-19+on+water+and+sanitation](https://www.ifc.org/wps/wcm/connect/industry_ext_content/ifc_external_corporate_site/infrastructure/resources/the+impact+of+covid-19+on+water+and+sanitation).
- Byrne, B.M., 2009. *Structural equation modeling with AMOS: basic concepts, applications, and programming*. In: *Multivariate Applications, second ed.* Routledge.
- Carbonara, N., Pellegrino, R., 2018. Revenue guarantee in public-private partnerships: a win-win model. *Construct. Manag. Econ.* 36, 584–598. <https://doi.org/10.1080/01446193.2018.1467028>.
- Castro, J.P., 2008. Water services in Latin America: experiences with public-private partnerships. *Int. J. Water* 4, 235–251. <https://doi.org/10.1504/IJW.2008.019496>.
- Chan, A.P.C., Lam, P.T.I., Chan, D.W.M., Cheung, E., Ke, Y., 2010. Critical success factors for PPPs in infrastructure developments: Chinese perspective. *J. Construct. Eng. Manag.* [https://doi.org/10.1061/\(asce\)co.1943-7862.0000152](https://doi.org/10.1061/(asce)co.1943-7862.0000152).
- Chen, C., Yu, Y., Osei-Kyei, R., Chan, A.P.C., Xu, J., 2019. Developing a project sustainability index for sustainable development in transnational public-private partnership projects. *Sustain. Dev.* 27, 1034–1048. <https://doi.org/10.1002/SD.1954>.
- Cherkos, F.D., Jha, K.N., Singh, A., 2020. Framework to select public-private partnership modalities. *J. Leg. Aff. Dispute Resolut. Eng. Constr.* 12. [https://doi.org/10.1061/\(ASCE\)LA.1943-4170.0000425](https://doi.org/10.1061/(ASCE)LA.1943-4170.0000425).
- Costello, A.B., Osborne, J., 2005. Best practices in exploratory factor analysis: four recommendations for getting the most from your analysis. *Res. Eval. Pract. Assessment, Res. Eval.* 10, 7. <https://doi.org/10.7275/jyjl-4868>.
- Cui, C., Liu, Y., Hope, A., Wang, J., 2018. Review of studies on the public private partnerships (PPP) for infrastructure projects. *Int. J. Proj. Manag.* 36, 773–794. <https://doi.org/10.1016/j.ijproman.2018.03.004>.
- Cui, C., Wang, J., Liu, Y., Coffey, V., 2019. Relationships among value-for-money drivers of public-private partnership infrastructure projects. *J. Infrastruct. Syst.* 25, 4019007. [https://doi.org/10.1061/\(ASCE\)IS.1943-555X.0000479](https://doi.org/10.1061/(ASCE)IS.1943-555X.0000479).
- Demirel, H.C., Leendertse, W., Volker, L., 2022. Mechanisms for protecting returns on private investments in public infrastructure projects. *Int. J. Proj. Manag.* 40, 155–166. <https://doi.org/10.1016/J.IJPROMAN.2021.11.008>.
- Dithebe, K., Aigbavboa, C.O., Thwala, W.D., Oke, A.E., 2019. Factor analysis of critical success factors for water infrastructure projects delivered under public-private partnerships. *J. Financ. Manag. Prop. Constr.* <https://doi.org/10.1108/JFMPC-06-2019-0049>.
- Efron, B., 1979. Bootstrap methods: another look at the jackknife. *Ann. Stat.* 7, 1–26. <https://doi.org/10.1214/aos/1176344552>.
- Ergönül, S., 2017. Success Factors for Construction Projects. *Tasarım + Kuram*. <https://doi.org/10.23835/tasarimkuram.537813>.
- Ferguson, C.R., Dickinson, R., 1982. Critical success factors for directors in the eighties. *Bus. Horiz.* [https://doi.org/10.1016/0007-6813\(82\)90123-9](https://doi.org/10.1016/0007-6813(82)90123-9).
- Grimsey, D., Lewis, M.K., 2004. Public private partnerships: the worldwide revolution in infrastructure provision and project finance. *Public Priv. Partnerships Worldw. Revolut. Infrastruct. Provis. Proj. Financ.* 1–268. <https://doi.org/10.4337/9781845423438>.

- Hinojosa, S.A., Mascle-Allemand, A.-L., Vieitez Martínez, D., 2020. Análisis costo-beneficio integral para evaluar la conveniencia de aplicar esquemas de asociaciones público-privadas en América Latina y el Caribe. <https://doi.org/10.18235/0002397>. Washington, D.C.
- Hou, W., You, S., Zhang, Y., 2022. Study on the selection of equity structure of PPP waste-to-energy projects from the perspective of sustainable development. *J. Environ. Plann. Manag.* 65, 2099–2123. <https://doi.org/10.1080/09640568.2021.1957795>.
- Hu, Y., Chan, A.P.C., Le, Y., Xu, Y., Shan, M., 2016. Developing a program organization performance index for delivering construction megaprojects in China: fuzzy synthetic evaluation analysis. *J. Manag. Eng.* 32, 05016007 [https://doi.org/10.1061/\(ASCE\)ME.1943-5479.0000432](https://doi.org/10.1061/(ASCE)ME.1943-5479.0000432).
- Jak, S., 2015. Meta-Analytic Structural Equation Modelling, SpringerBriefs in Research Synthesis and Meta-Analysis. Springer International Publishing. <https://doi.org/10.1007/978-3-319-27174-3>.
- Jefferies, M., Gameson, R., Rowlinson, S., 2002. Critical success factors of the BOOT procurement system: reflections from the Stadium Australia case study. *Eng. Construct. Architect. Manag.* <https://doi.org/10.1108/eb021230>.
- Jha, K.N., Iyer, K.C., 2006. Critical factors affecting quality performance in construction projects. *Total Qual. Manag. Bus. Excel.* <https://doi.org/10.1080/14783360600750444>.
- Jiang, Y., 2016. Selection of PPP projects in China based on government guarantees and fiscal risk control. *Int. J. Financ. Res.* 8, 99. <https://doi.org/10.5430/IJFR.V8N1P99>.
- Kalbusch, A., Henning, E., Brikalski, M.P., Luca, F.V. de, Konrath, A.C., 2020. Impact of coronavirus (COVID-19) spread-prevention actions on urban water consumption. *Resour. Conserv. Recycl.* <https://doi.org/10.1016/j.resconrec.2020.105098>.
- Lam, E.W., Chan, A.P., Chan, D.W., 2008. Determinants of successful design-build projects. *J. Construct. Eng. Manag.* 134, 333–341. [https://doi.org/10.1061/\(ASCE\)0733-9364\(2008\)134:5\(333\)](https://doi.org/10.1061/(ASCE)0733-9364(2008)134:5(333)).
- Li, H., Xia, Q., Wen, S., Wang, L., Lv, L., 2019. Identifying factors affecting the sustainability of water environment treatment public-private partnership projects. *Adv. Civ. Eng.* <https://doi.org/10.1155/2019/7907234>.
- Liu, J., Love, P.E.D., Smith, J., Regan, M., Davis, P.R., 2014. Life cycle critical success factors for public-private partnership infrastructure projects. *J. Manag. Eng.* 31, 04014073 [https://doi.org/10.1061/\(ASCE\)ME.1943-5479.0000307](https://doi.org/10.1061/(ASCE)ME.1943-5479.0000307).
- Marin, P., 2009. Public-Private Partnerships for Urban Water Utilities, Public-Private Partnerships for Urban Water Utilities. The World Bank. <https://doi.org/10.1596/978-0-8213-7956-1>.
- Mazher, K.M., Chan, A., Zahoor, H., Khan, M.I., Ameyaw, E., 2018. Fuzzy integral-based risk-assessment approach for public-private partnership infrastructure projects. *J. Construct. Eng. Manag.* 144, 4018111 [https://doi.org/10.1061/\(ASCE\)CO.1943-7862.0001573](https://doi.org/10.1061/(ASCE)CO.1943-7862.0001573).
- Meng, X., Zhao, Q., Shen, Q., 2011. Critical success factors for transfer-operate-transfer urban water supply projects in China. *J. Manag. Eng.* 27, 243–251. [https://doi.org/10.1061/\(asce\)me.1943-5479.0000058](https://doi.org/10.1061/(asce)me.1943-5479.0000058).
- Mousavizade, F., Shakibzadeh, M., 2019. Identifying and ranking CSFs for KM implementation in urban water and sewage companies using ISM-DEMATEL technique. *J. Knowl. Manag.* <https://doi.org/10.1108/JKM-05-2018-0321>.
- Opawole, A., Jagboro, G.O., Kajimo-Shakantu, K., Olojede, B.O., 2019. Critical performance factors of public sector organizations in concession-based public-private partnership projects. *Property Manag.* 37, 17–37. <https://doi.org/10.1108/PM-09-2017-0052>.
- Osei-Kyei, R., Chan, A., 2017a. Implementing public-private partnership (PPP) policy for public construction projects in Ghana: critical success factors and policy implications. *Int. J. Constr. Manag.* 17, 113–123. <https://doi.org/10.1080/15623599.2016.1207865>.
- Osei-Kyei, R., Chan, A.P.C., 2017b. Developing a project success index for public-private partnership projects in developing countries. *J. Infrastruct. Syst.* 23, 04017028 [https://doi.org/10.1061/\(ASCE\)IS.1943-555X.0000388](https://doi.org/10.1061/(ASCE)IS.1943-555X.0000388).
- Osei-Kyei, R., Chan, A.P.C., 2017c. Risk assessment in public-private partnership infrastructure projects Empirical comparison between Ghana and Hong Kong. *Construct. Innovat.* 17, 204–223. <https://doi.org/10.1108/CI-08-2016-0043>.
- Osei-Kyei, R., Chan, A.P.C., 2018. Public sector's perspective on implementing public-private partnership (PPP) policy in Ghana and Hong Kong. *J. Facil. Manag.* 16, 175–196. <https://doi.org/10.1108/JFM-06-2017-0026>.
- Osei-Kyei, R., Chan, A.P.C., 2019. Model for predicting the success of public-private partnership infrastructure projects in developing countries: a case of Ghana. *Architect. Eng. Des. Manag.* 15, 213–232. <https://doi.org/10.1080/17452007.2018.1545632>.
- Osei-Kyei, R., Chan, A.P.C., Ameyaw, E.E., 2017. A fuzzy synthetic evaluation analysis of operational management critical success factors for public-private partnership infrastructure projects. *Benchmarking-an Int. J.* 24, 2092–2112. <https://doi.org/10.1108/BJL-07-2016-0111>.
- Osei-Kyei, R., Chan, A.P.C., Dansoh, A., Ofori-Kuragu, J.K., Oppong, G.D., 2018. Strategies for effective management of unsolicited public-private partnership proposals. *J. Manag. Eng.* [https://doi.org/10.1061/\(asce\)me.1943-5479.0000598](https://doi.org/10.1061/(asce)me.1943-5479.0000598).
- Osei-Kyei, R., Chan, A., Yao, Y., Mazher, K.M., 2019a. Conflict prevention measures for public-private partnerships in developing countries. *J. Financ. Manag. Prop. Constr.* 24, 39–57. <https://doi.org/10.1108/JFMPC-06-2018-0032>.
- Osei-Kyei, R., Chan, A.P.C., Yu, Y., Chen, C., Dansoh, A., 2019b. Root Causes of Conflict and Conflict Resolution Mechanisms in Public-Private Partnerships: Comparative Study between Ghana and China. <https://doi.org/10.1016/j.cities.2018.10.001>. Cities.
- Osei-Kyei, R., Chan, A.P.C., Yu, Y., Chen, C., Ke, Y., Tijani, B., 2019c. Social responsibility initiatives for public-private partnership projects: a comparative study between China and Ghana. *Sustainability* 11, 1338. <https://doi.org/10.3390/su11051338>.
- Osei-Kyei, R., Chan, A.P.C., Dansoh, A., 2020. Project selection index for unsolicited public-private partnership proposals. *Int. J. Constr. Manag.* <https://doi.org/10.1080/15623599.2019.1573480>.
- Pellegrino, R., 2021. Effects of public supports for mitigating revenue risk in public-private partnership projects: model to choose among support alternatives. *J. Construct. Eng. Manag.* 147, 04021167 [https://doi.org/10.1061/\(ASCE\)CO.1943-7862.0002098](https://doi.org/10.1061/(ASCE)CO.1943-7862.0002098).
- PPIAF, 2014. Estudio de caso. Contrato de mejoras integrales de los servicios de agua potable en el Distrito de Colón, Panamá. Public-Private Infrastructure Advisory Facility. PPIAF, Washington, DC.
- Raykov, T., Marcoulides, G.A., 2008. *An Introduction to Applied Multivariate Analysis*, first ed. Routledge.
- Shi, S., Chong, H.Y., Liu, L., Ye, X., 2016. Examining the interrelationship among critical success factors of public private partnership infrastructure projects. *Sustain. Times* 8, 1313. <https://doi.org/10.3390/SU8121313>, 1313 8 2016.
- Swamy, R.R.D.T.V., Tiwari, P., Sawhney, A., 2018. Assessing determinants of PPP project performance Applying AHP to urban drinking water sector in India. *Property Manag.* 36, 67–85. <https://doi.org/10.1108/PM-08-2016-0046>.
- Tariq, S., Zhang, X., 2021. Socioeconomic, macroeconomic, and sociopolitical issues in water PPP failures. *J. Manag. Eng.* 37, 04021047 [https://doi.org/10.1061/\(ASCE\)ME.1943-5479.0000947](https://doi.org/10.1061/(ASCE)ME.1943-5479.0000947).
- Tariq, S., Zhang, X., Leung, R.H.M., 2019. An analytical review of failed water public-private partnerships in developing countries. *Proc. Inst. Civ. Eng. Procure. Law* 172, 60–69. <https://doi.org/10.1680/jmapl.18.00042>.
- Tharmakulasingham, K., Pasindu, H.R., 2021. Development of a framework for identifying highway projects for private-public-partnership financing. *Eng. J. Inst. Eng. Sri Lanka* 54, 49. <https://doi.org/10.4038/ENGINEER.V54I0.7452>.
- Thierie, W., De Moor, L., 2017. Constraints related to developing small-scale PPPs and how to reduce them. *Int. J. Manag. Proj. Bus.* 10, 109–120. <https://doi.org/10.1108/IJMPB-04-2016-0037/FULL/XML>.
- Tucker, M., Turley, M., Holgate, S., 2014. Critical Success Factors of an Effective Repairs and Maintenance Service for Social Housing in the UK. <https://doi.org/10.1108/F-07-2012-0059>. Facilities.
- Unicef-Oms, 2021. Progress on Household Drinking Water, Sanitation and Hygiene 2000–2020 Five Years into the SDGs. WHO/UNICEF Joint Monitoring Programme for Water Supply, Sanitation and Hygiene (JMP). New York.
- Who, 2020. Water, Sanitation, Hygiene, and Waste Management for SARS-CoV-2, the Virus that Causes COVID-19 [WWW Document]. Interim Guid. URL. <https://www.who.int/publications/i/item/water-sanitation-hygiene-and-waste-management-for-the-covid-19-virus-interim-guidance>.
- World Bank, 2017. Public Private Partnerships. Reference Guide 3.0. International Bank for Reconstruction and Development/The World Bank, Washington DC.
- World Bank, 2018. Procuring Infrastructure PPPs 2018 (Washington, DC).
- Wu, Q., Gao, Y., 2012. Selection model of concessionaire in PPP projects. *Appl. Mech. Mater.* 174–177, 2906–2910. <https://doi.org/10.4028/WWW.SCIENTIFIC.NET/AMM.174-177.2906>.
- Xiong, W., Chen, B., Wang, H., Zhu, D., 2019. Governing public-private partnerships: a systematic review of case study literature. *Aust. J. Publ. Adm.* 78, 95–112. <https://doi.org/10.1111/1467-8500.12343>.
- Xmind, 2020. XMind Pro Computer Software.
- Xu, Y., Yeung, J.F.Y., Chan, A.P.C., Chan, D.W.M., Wang, S.Q., Ke, Y., Chan, A.P.C., Chan, D.W.M., Wang, S.Q., Ke, Y., 2010. Developing a risk assessment model for PPP projects in China - a fuzzy synthetic evaluation approach. *Autom. Construct.* 19, 929–943. <https://doi.org/10.1016/j.autcon.2010.06.006>.
- Xu, Y., Chan, A.P.C., Xia, B., Qian, Q.K., Liu, Y., Peng, Y., 2015. Critical risk factors affecting the implementation of PPP waste-to-energy projects in China. *Appl. Energy.* <https://doi.org/10.1016/j.apenergy.2015.08.043>.
- Yeung, J.F., Chan, A.P., Chan, D.W., 2009. Developing a performance index for relationship-based construction projects in Australia: Delphi study. *J. Manag. Eng.* 25, 59–68. [https://doi.org/10.1061/\(ASCE\)0742-597X\(2009\)25:2\(59\)](https://doi.org/10.1061/(ASCE)0742-597X(2009)25:2(59)).
- Youneszadeh, H., Ardeshtir, A., Sebt, M.H., 2017. Exploring critical success factors in urban housing projects using fuzzy analytic network process. *Civ. Eng. J.* 3, 1048. <https://doi.org/10.28991/cej-030937>.
- Yu, Y., Chan, A.P.C., Chen, C., Darko, A., 2018a. Critical risk factors of transnational public-private partnership projects: literature review. *J. Infrastruct. Syst.* 24, 4017042 [https://doi.org/10.1061/\(ASCE\)IS.1943-555X.0000405](https://doi.org/10.1061/(ASCE)IS.1943-555X.0000405).
- Yu, Y., Darko, A., Chan, A.P.C., Chen, C., Bao, F., 2018b. Evaluation and ranking of risk factors in transnational public-private partnerships projects: case study based on the intuitionistic fuzzy analytic hierarchy process. *J. Infrastruct. Syst.* 24, 4018028 [https://doi.org/10.1061/\(ASCE\)IS.1943-555X.0000448](https://doi.org/10.1061/(ASCE)IS.1943-555X.0000448).
- Zhang, X., 2004a. Improving concessionaire selection protocols in public/private partnered infrastructure projects. *J. Construct. Eng. Manag.* 130, 670–679. [https://doi.org/10.1061/\(ASCE\)0733-9364\(2004\)130:5\(670\)](https://doi.org/10.1061/(ASCE)0733-9364(2004)130:5(670)).
- Zhang, X., 2004b. Concessionaire selection: methods and criteria. *J. Construct. Eng. Manag.* 130, 235–244. [https://doi.org/10.1061/\(ASCE\)0733-9364\(2004\)130:2\(235\)](https://doi.org/10.1061/(ASCE)0733-9364(2004)130:2(235)).
- Zhang, X., 2005a. Criteria for selecting the private-sector partner in public-private partnerships. *J. Construct. Eng. Manag.* [https://doi.org/10.1061/\(asce\)0733-9364\(2005\)131:6\(631\)](https://doi.org/10.1061/(asce)0733-9364(2005)131:6(631)).

- Zhang, X., 2005b. Critical success factors for public-private partnerships in infrastructure development. *J. Construct. Eng. Manag.* [https://doi.org/10.1061/\(ASCE\)0733-9364\(2005\)131:1\(3\)](https://doi.org/10.1061/(ASCE)0733-9364(2005)131:1(3)).
- Zhang, L., Sun, X., Xue, H., 2019. Identifying critical risks in Sponge City PPP projects using DEMATEL method: a case study of China. *J. Clean. Prod.* 226, 949–958. <https://doi.org/10.1016/j.jclepro.2019.04.067>.
- Zhao, Z.-Y.Y., Zuo, J., Zillante, G., Wang, X.-W.W., 2010. Critical success factors for BOT electric power projects in China: thermal power versus wind power. *Renew. Energy* 35, 1283–1291. <https://doi.org/10.1016/j.renene.2009.09.016>.

**Jaime Muñoz-Jofre** is a PhD candidate in Environmental Engineering at the University of Cantabria (Spain), holds a degree in Construction Engineering (Chile) and a Master of Sciences degree in Sanitary and Environmental Engineering (Spain). His professional career is associated with several university R&D projects, mainly in the areas of water supply, sanitation and solid waste, in European and Latin American cities.

**Sergio Hinojosa** holds a degree in economics, a degree in Business Administration and a PhD in Management Sciences with a specialization in financial economics from ESADE

Business School (Spain). He also holds a Master of Arts in Economics from Georgetown University and a Master of Sciences in Finance from The George Washington University. He has extensive experience in public project finance, public-private partnerships, public asset management models and project evaluation methodologies.

**Anne-Laure Mascle-Allamande** holds a PhD in Economics from the Toulouse School of Economics (TSE), France and has more than 15 years of professional experience with extensive knowledge in socio-economic evaluation of investment projects, identification, evaluation and selection of Public-Private Partnership (PPP) projects and design and strengthening of public investment systems.

**Javier Temprano** holds a PhD in Civil Engineering from the University of Cantabria (Spain). He is an associate professor of the university and researcher of the Environmental Engineering group of the Department of Water and Environmental Sciences and Techniques. He has extensive experience in the development of applied research work in water supply, urban sanitation and solid waste projects. He has several publications in scientific journals and experience in the direction of doctoral and master's theses in science, collaborating with various research groups.