

SECTION II. GENETIC STUDY

BY

J. VALŠÍK,* D. ŽITŇAN,† AND Š. SIT'AJ†

* *From the Department of Anthropology and Genetics, J. A. Komenský University, Bratislava.*† *From the Research Institute of Rheumatic Diseases, Piešťany, Czechoslovakia.*

Our first observations had shown that articular chondrocalcinosis (AC) occurred in several members of the same family. As the original material was of a smaller extent (Žitňan and Sit'aj, 1958, 1960*a, b*; Sit'aj, Žitňan, Trnavská, and Valšík, 1962), we used the more general denomination "familial". We did not intend to exclude the possibility of hereditary transmission, but could not then be sure that the disease might not perhaps have been caused by environmental factors.

The genetic investigation which was undertaken in the homes of our first patients revealed a total of 27 patients of whom only six subjects were, so far at least, solitary cases. The other 21 were members of five different families, the genealogical trees of which are shown in Figs 15 to 19 (overleaf).

Of these 27 patients, 22 were natives of one locality and five of various other localities.

Now, having assembled what is so far the largest series of cases under observation, we feel able to classify articular chondrocalcinosis as an hereditary condition and to abandon the initial designation of "familial". Our opinion is particularly well supported by the third family "BAL" comprising the descendants of two brothers who live quite separately and independently of each other. Similarly, in the fourth family "BUG", the affection occurs in second cousins. Our opinion is equally well supported by the fact that in each family the affection occurs in only one parent.

As shown in the clinical and radiological analysis (Žitňan and Sit'aj, 1963) articular chondrocalcinosis occurs in two forms and this permits the presumption that it occurs in two phenotypes:

- (a) The polyarticular form, which usually develops in youth, progresses relatively rapidly, and affects a great number of joints;
- (b) The oligoarticular form, which develops at a more advanced age, affects fewer joints, and soon becomes stationary. This form does not produce excessively severe symptoms, and some cases may even be "sub-clinical" (Family "MIK", II.2).

Both forms were encountered in each family.

Family Trees

(1) Family MIK (Fig. 15)

In Generation II there are two affected persons (II.2 and II.13) both with the oligoarticular type of disease (Cases 1 and 2).

In Generation III the elder sister (II.2) has three affected children (III.1, 6, and 9) all markedly polyarticular (Cases 3, 4, and 5).

(2) Family FOR (Fig. 16)

The eldest of seven brothers (II.1) has the oligoarticular type of disease (Case 6), and three of his four children (III.2, 4, and 8) all have the polyarticular type (Cases 7, 8, and 9).

(3) Family BAL (Fig. 17)

All members of Generations I and II are dead.

In Generation III, two sisters (III.11, oligoarticular, and III.13, polyarticular) are affected (Cases 11 and 12), and also their cousin (III.6, oligoarticular, Case 10).

In Generation IV, two children of III.13 (*i.e.* IV.24 and 27) both have the polyarticular type (Cases 13 and 14).

(4) Family BUG (Fig. 18)

All members of Generations I and II are dead.

In Generation III, those affected are III.3 (Case 15, polyarticular) and III.5 and III.11 (Cases 16 and 17, oligoarticular).

In Generation IV, a daughter of III.3 (IV.8, Case 18) has an incipient oligoarticular type of disease and her female cousin (IV.38, Case 19) the polyarticular type.

This pedigree chart is incomplete because many members of the family live abroad.

(5) Family POT (Fig. 19)

In Generation II, the eldest brother (II.1) has the polyarticular type (Case 20) and his daughter (III.3) has an incipient oligoarticular type (Case 21). This family belongs to an area totally different from that inhabited by the nineteen patients of the four other families.

The six solitary cases in which the family histories could not be investigated involve patients whose parents are not alive, so that the possibility that they were carriers of the disease cannot be affirmed or denied.

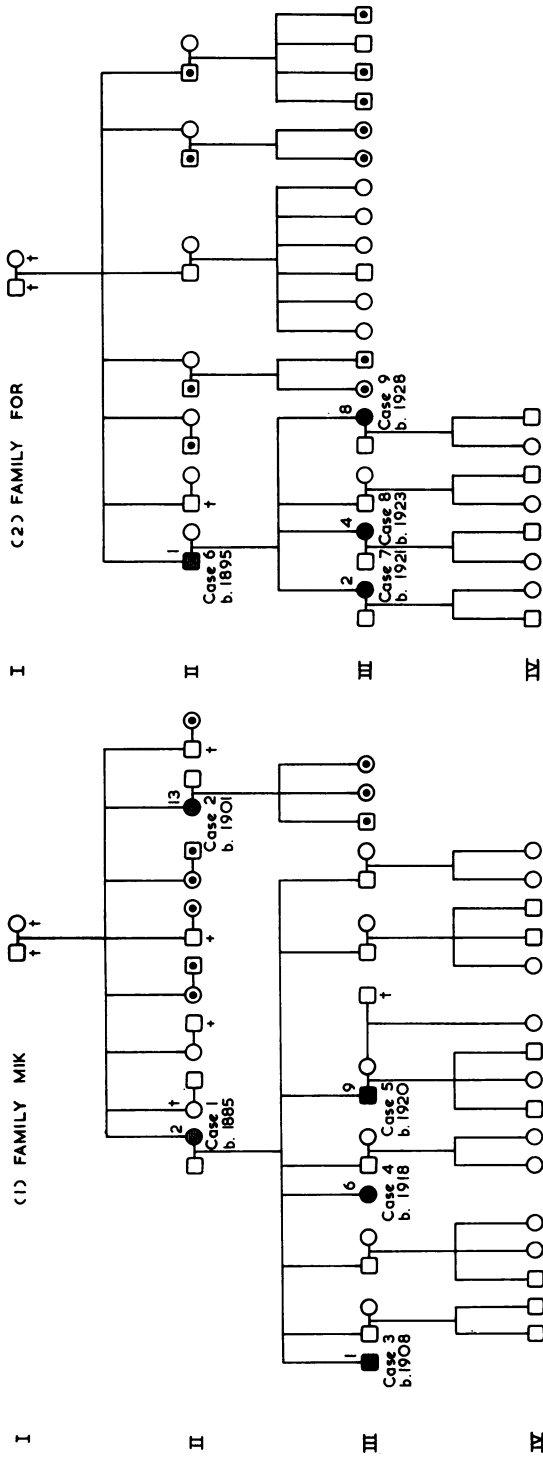

Fig. 15.—Pedigree (1) Family Mik.

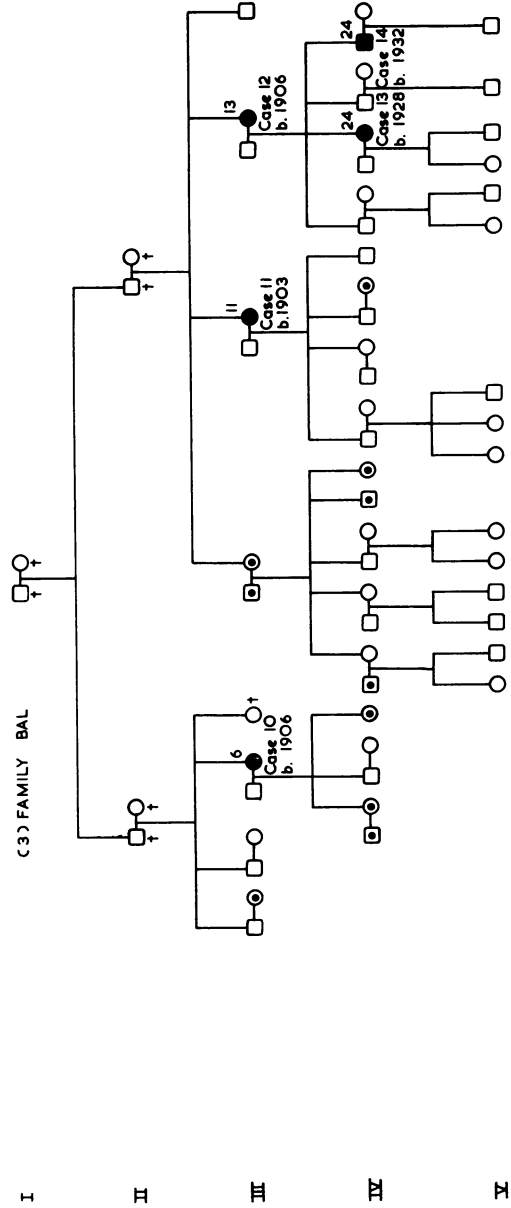

Fig. 16.—Pedigree (2) Family For.

Fig. 17.—Pedigree (3) Family Bel.

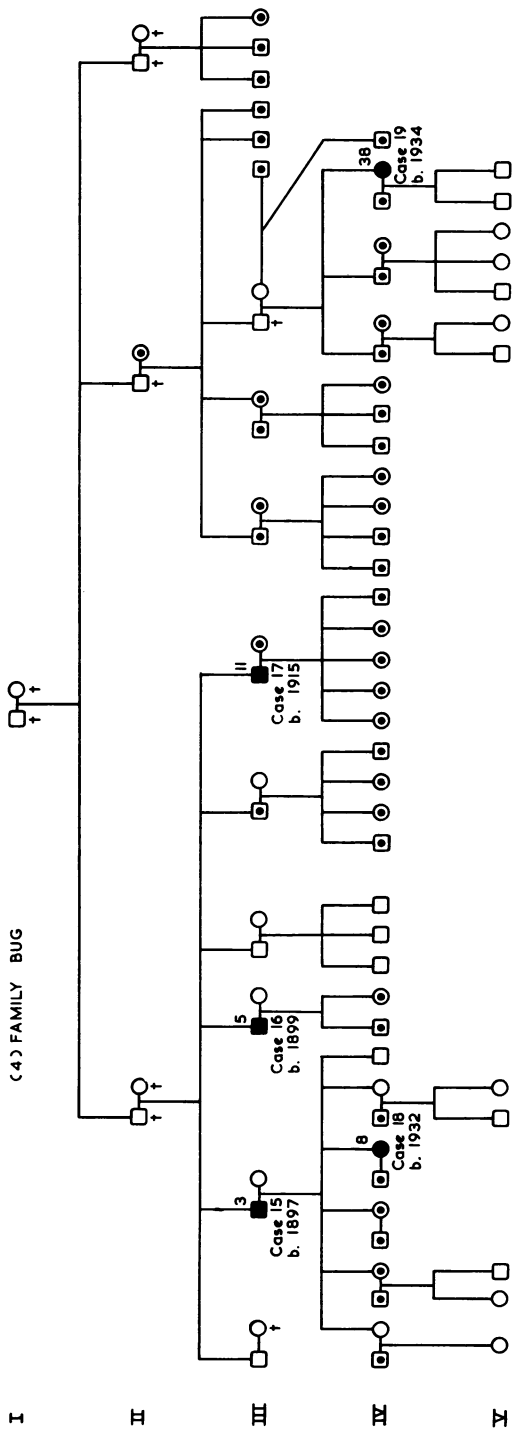

Fig. 18.—Pedigree (4) Family Bug.

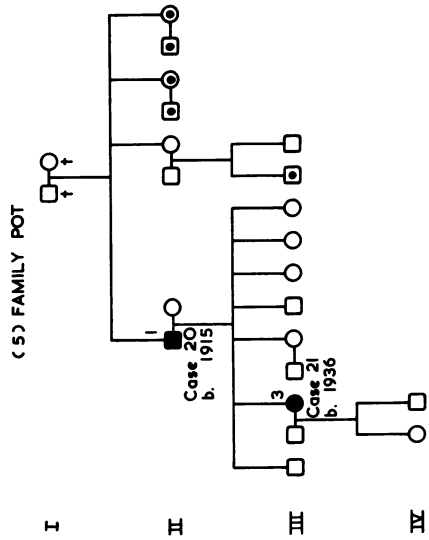

Fig. 19.—Pedigree (5) Family Pot.

In studying these pedigrees it must be remembered that articular chondrocalcinosis manifests itself clinically in the third decade of life at the earliest. We have confirmed that the disease could not be diagnosed in the members of the youngest generation. The phenomenon whereby the disease manifests itself only in adult life is called change of dominance. Whether the disease is provoked at this critical age by changes in the internal condition (hormonal or metabolic, for example) of the subject, cannot as yet be decided, but the change of dominance must be taken into account, and one should recognize that it tends to hinder observation of its hereditary character.

The individual hereditary cases are summarized in Table III. The ratio of patients to unaffected subjects in the 32 children in these families is 10 : 22. The patients include three sons and seven daughters, while fifteen sons and seven daughters remain unaffected, which suggests that the affection is more common in daughters than in sons. The fact that the 21 affected subjects in these families include eight males and thirteen females also suggests a predominance of females over males.

Let us suppose, purely hypothetically, without regard to the type of disease, that the cause lies in the mutation of the locus in one pair of alleles. If so, the case might involve dominant, recessive, or intermediary heredity. The last is out of the question as it may be seen at the first glance at these pedigrees. Evidence for dominant heredity is that the disease does not leave out any generation;

however, the fact that the first four pedigrees include family groups living in the same locality suggests the recessive heredity. Hence, it is possible to presume that healthy family members are dominant heterozygotes while the patients are recessive homozygotes. In a locality where most of the population is more or less akin it would not be perhaps too remote a possibility for recessive homozygotes to marry dominant heterozygotes. On the other hand, one would also expect two dominant heterozygotes to marry so that the disease "skips" one generation. This is why we are inclined to favour the dominant type of hereditary factor.

Among the children of the affected families the ratio of patients to healthy individuals is 10 : 22. However, if the heredity were dependent upon a single mutation in one pair of alleles, one would expect that the ratio of patients to unaffected subjects to be 1 : 1. Statistically, using the χ^2 test, the results are as follows, on the basis of one degree of freedom, $P = 0.02 - 0.05$. This means that the difference between the established and expected ratio is real, which is against our presumption. On the other hand these descendants include many young subjects in whom the disease may eventually develop at a later age, so that a ratio of 1 : 1 may be established by future studies.

Our present observations have not allowed us to decide whether the hereditary transmission of articular chondrocalcinosis is bound to the sex chromosome. If the affection were a recessive trait, heredity would occur only in males and the

TABLE III
TEN AFFECTED AND 22 UNAFFECTED CHILDREN OF SEVEN AFFECTED PARENTS IN FIVE FAMILIES

Family	Affected Parents	Children		
		Affected	Unaffected	Ratio Affected : Unaffected
(1) MIK	II.2 Mother (Case 1)	M. III.1 (Case 3), III.9 (Case 5) F. III.6 (Case 4)	M. III.2, III.4, III.7, III.12, III.14 F. —	3 : 5
(2) FOR	II.1 Father (Case 6)	M. — F. III.2, III.4, III.8 (Cases 7, 8, 9)	M. III.5 F. —	3 : 1
(3) BAL	III.6 Mother (Case 10)	M. — F. —	M. IV.3 F. —	0 : 1
	III.11 Mother (Case 11)	M. — F. —	M. IV.14, IV.18, IV.20 F. IV.17	0 : 4
	III.13 Mother (Case 12)	M. IV.27 (Case 13) F. IV.24 (Case 14)	M. IV.21, IV. 25 F. —	2 : 2
(4) BUG	III.3 Father (Case 15)	M. — F. IV.8 (Case 18)	M. IV.11 F. IV.2, IV.10	1 : 3
(5) POT	II.1 Father (Case 20)	M. — F. III.3 (Case 21)	M. III.1, III.6 F. III.5, III.7, III.8, III.9	1 : 6
Total	7 (3 M., 4 F.)	10 (3 M., 7 F.)	22 (15 M., 7 F.)	10 : 22

females would be carriers. The recessive transmission by sex chromosomes of this trait does not affect the argument because these families include a relatively large number of affected males. If the transmission were dominant, all daughters of an affected father would necessarily be affected. The numbers involved in the present investigation do not as yet afford any support for this presumption, but many of the unaffected daughters have not yet attained the age at which the change of dominance could manifest itself.

Point mutation, affecting one chromosome in the pair of alleles, seems to be involved, but it is not yet possible to decide whether the transmission is dominant or recessive and whether the mutation is

localized in a sex chromosome or in an autosome.

Dominant heredity is suggested by the fact that no generation was "skipped", but recessive heredity may be suggested by the fact that the members of four of the five pedigrees investigated belong to the same locality and perhaps be distantly related. Transmission by sex chromosomes is suggested by the fact that only daughters of affected fathers (though not all of them) are so far affected, and none of their sons. This interpretation would be possible only if the trait localized in the X-chromosome were dominant.

The full analysis of the hereditary transmission will have to wait until the last generation reaches the third and fourth decades of life.