

# Genetic Diversity in Serum Albumin

MORTON S. ADAMS\*

*From the Departments of Pediatrics and Human Genetics, University of Michigan School of Medicine, Michigan, U.S.A.*

The significance of rare, recessive genes occurring at a frequency that could be maintained by recurrent mutation alone is poorly understood. This paper presents the results of a genetic study and certain biochemical observations on a slowly migrating electrophoretic species of albumin which was found in the family of a 7-year-old boy suffering from the nephrotic syndrome. The gene controlling this slowly migrating albumin is apparently rare; however, at least 12 families with this trait have been reported (Scheurlen, 1955; Knedel, 1957, 1958; Nennstiel and Becht, 1957; Earle, Hutt, Schmid, and Gitlin, 1959; Bennhold, Ott, and Scheurlen, 1958; Franglen, Martin, Hargreaves, Smith, and Williams, 1960; Wieme, 1960; Miescher, 1960; Adner and Redfors, 1961; Robbins, Hill, Marcus, and Carlquist, 1963; Braend, Efremor, Fagerhol, and Hartmann, 1965). These data suggest that the mutant allele is as efficient as the wild type allele.

## Case Report

J.O. was referred to the University of Michigan Medical Center because of persistent abdominal distension following steroid treatment for the nephrotic syndrome. The onset of his nephrotic syndrome was typical and laboratory studies had demonstrated hypoalbuminaemia, hypercholesterolaemia, and proteinuria. The proteinuria had cleared after 15 days of treatment.

Past medical history was remarkable in that he had been treated with antituberculosis medications for one year following the discovery of a positive old tuberculin skin test.

On physical examination the liver edge was palpable 6 cm. below the right costal margin and ascitic fluid was demonstrable. Urinalysis and intravenous pyelography were normal. Two lupus erythematosus cell preparations were negative. Total serum protein was 5.3 g./100 ml., with 56% albumin as determined by paper electrophoresis. It was noted that there were two bands of approximately equal density in the albumin region.

The clinical diagnosis of nephrotic syndrome in remission was made. It was suspected that the hepatomegaly and ascites were secondary to steroid treatment and the steroids were promptly tapered with a concurrent decrease in abdominal girth, weight, and hepatomegaly. At the time of discharge he was completely off steroids, and there was no significant hepatomegaly or ascites. He has been followed since discharge on a programme of intermittent steroid therapy with no exacerbations or complications.

**Family Studies.** All available members of the patient's family were investigated when electrophoresis of his mother's serum also revealed two albumin bands. Of the 57 members of the family examined, 22 were shown to have this anomaly (Fig. 1). All were healthy and gave no history of significant illness. The deceased members of the family died either in old age or from infectious disease. No known pregnancy loss occurred in families with an affected parent.

**Biochemical Data.** The albumin anomaly as observed on paper and starch gel electrophoresis (Smithies, 1955) was clearly defined as a band migrating immediately behind normal albumin (Fig. 2). The two bands were distinctly separated with very little overlap. The same electrophoretic pattern was observed in the sera from all affected members of the family (Table). All determinations of the total serum proteins were normal as were the percentages of the total serum protein contributed by albumin. The rest of the electrophoretic pattern was unremarkable in each of the affected persons.

The proportion of the total albumin contributed by each of the two species of albumin was of particular interest. The mean ratio,  $0.9729 \pm 0.27$ , did not differ significantly from a 1 : 1 ratio,  $p \approx 0.64$ . It is important to realize that some of the variance observed in this ratio could be due to streaming of the normal albumin and incomplete separation of  $\alpha$  globulin from slow albumin.

Immunoelectrophoresis, using the technique of Scheidegger (1955) and undiluted serum, demonstrated an identical reaction with normal albumin.

**Genetic Analysis.** In 4 generations, 22 people were proved and one was assumed to have the slowly migrating albumin fraction (Fig. 1). In no case was the trait transmitted through an unaffected person. The deceased maternal great-grandmother is assumed to be the first

Received December 9, 1965.

\* Present address: Human Genetics Branch, National Institute of Dental Research, National Institutes of Health, Bethesda 14, Maryland 20014.

*Genetic Diversity in Serum Albumin*

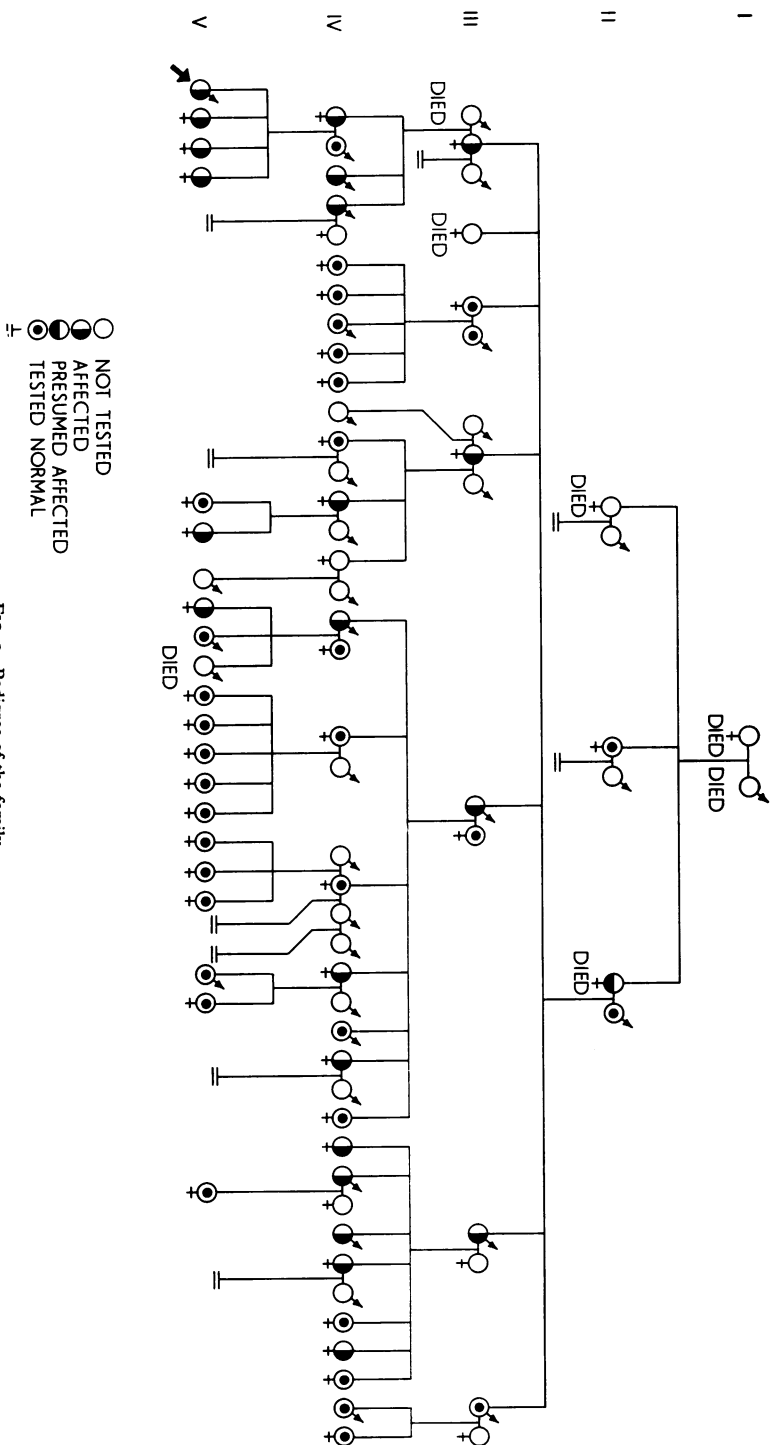

Fig. 1. Pedigree of the family.

TABLE  
BIOCHEMICAL DATA ON 18 PEOPLE WITH SLOW ALBUMIN

Subject	Total Serum Protein (g./100 ml.)	Albumin			% Total Protein			% Normal/% Slow
		Normal	Slow	$\alpha_1$	$\alpha_2$	$\beta$	$\gamma$	
E.P.	—	28.77	32.08	1.42	9.91	10.38	17.45	0.8968
E.W.	—	29.47	27.54	0.97	11.11	14.01	16.91	1.0700
P.W.	—	21.27	37.31	2.24	12.31	13.43	13.43	0.5700
M.O.	7.59	29.35	27.86	1.99	10.95	13.43	16.41	1.0534
C.C.	7.06	34.30	34.78	1.45	7.73	8.70	13.04	0.9861
C.C.	7.02	32.30	34.51	2.21	9.29	8.41	13.27	0.9359
F.W.	—	27.39	30.87	1.74	10.87	13.48	15.65	0.8872
E.W., Jr.	—	27.19	33.77	1.31	9.65	10.09	17.98	0.8051
B.H.	—	28.80	35.33	0.54	10.33	8.70	16.30	0.8151
G.K.	—	24.03	36.40	0.35	11.66	10.95	16.61	0.6601
C.W.	—	28.74	32.39	2.43	10.12	10.53	15.79	0.8873
T.W.	—	29.60	33.18	2.24	8.07	12.56	14.35	0.8921
J.O.	7.03	28.44	33.94	1.38	9.63	13.30	13.30	0.8379
B.O.	6.86	31.96	31.96	1.83	10.05	10.05	14.16	1.0000
S.O.	7.10	37.74	29.25	1.42	9.43	8.96	13.21	1.2902
D.O.	—	35.15	33.17	1.49	9.90	11.39	8.91	1.0596
D.W.	—	27.98	28.44	1.83	9.17	$\beta_1$ 15.14 $\beta_2$ 6.42	11.01	0.9838
C.W.	—	39.67	21.07	1.24	7.02	18.10	12.81	1.8827

affected member of this kindred, since her living spouse had only normal albumin and 4 of the 6 living children of this union were affected.

No significant difference was demonstrated in the efficiency of the two alleles in producing their respective

albumins. This suggests that the trait is controlled by co-dominant alleles. This designation implies that in the heterozygous condition both alleles find equal expression. Due to the rarity of this condition, the mating most likely to give information on the mode of inheritance will involve a heterozygote with a normal homozygote. A 1 : 1 ratio between affected and normal children would be expected from such matings.

The hypothesis of a 1 : 1 ratio of affected and normal offspring among the 9 sibships of 2 or more children where one parent is affected was tested. No significant deviation from the hypothesis and no significant heterogeneity of the sexes were found.

### Discussion

Most of the reported families came to medical attention through an affected member who was being followed with some other diagnosis. No disease was common to these propositi, and in all the families studied many people with the trait have been completely well. To date no advantage or disadvantage has been observed for this anomaly.

The biochemical observations made on heterozygotes in these families have shown the abnormal protein to be present in approximately the same quantity as normal albumin. Ultracentrifugation, immunological and immunoelectrophoretic tests have consistently shown the abnormal albumin to be identical to normal albumin. However, Robbins *et al.* (1963) detected equivocal evidence of minor differences in antigenic specificity using immunoelectrophoretics of diluted serum. Gitlin, Schmid, Earle, and Givelber (1961) demonstrated a peptide difference between the two albumins present in the

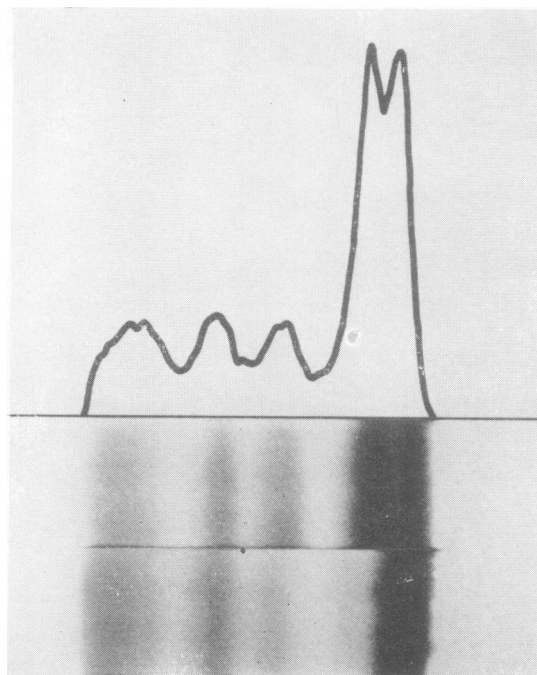

Fig. 2. Paper electrophoretic pattern of serum of propositus (upper) and normal control (lower).

family studied by Earle *et al.* (1959). Their data indicate that a lysine residue in the slowly migrating albumin probably replaces a group containing a free carboxyl radical in normal albumin. No evidence is available as to a functional distinctness of these proteins.

Twenty-nine sibships of two or more children reported by Adams (this report), Earle *et al.* (1959), Franglen *et al.* (1960), Miescher (1960), and Adner and Redfors (1961) were pooled. No significant departure from a 1 : 1 ratio of affected to normal offspring was obtained, and there was no significant heterogeneity of the sexes. However, this pooling may not be valid since the structural identity of the anomalous albumins is not established.

The homozygous affected genotype has never been observed. Due to the apparent rareness of the gene it would be expected to occur only as a result of a consanguineous union or perhaps in certain areas of Germany and Switzerland where several affected families have been observed. Data on the frequency of the gene responsible for the slow albumin are scanty, but the gene must be very rare and probably does not reach even the 1% level. Efremov and Braend (1964) found one case in 1015 normal Norwegian individuals, and Cohen (1965) found none in 548 Scottish hospital patients.

Evidence supporting the hypothesis of co-dominant inheritance of the slow versus normal albumin is available from studies in several species of domestic animals including chickens (McIndoe, 1962), horses (Stormont and Suzuki, 1963), cattle (Ashton and Lampkin, 1965), turkeys (Quinteros, Stevens, Stormont, and Asmundson, 1964), and quail (Haley, 1965). In these species balanced polymorphisms apparently occur.

It has been suggested that the presence of slow albumin is due to the continued production of a normal foetal protein. Bergstrand and Czar (1957) reported such a protein in 39 foetuses aged 9–19 weeks (19–27 cm.) but in none of the 11 premature infants they studied. The slowly migrating protein observed in the foetuses was identical to albumin by ultracentrifugation and precipitated in ammonium sulphate.

Human serum albumin has been characterized by its uniformity (Goodman, 1962). Electrophoretic variants, at least, are rare. Those that do occur appear to be antigenically identical to normal albumin. Goodman (1962) has postulated that variation in proteins that are present in the early foetus (such as albumin) is limited by the maternal immune mechanism. This implies a potentially high level of selective control over the production of albumin. The existence of rare an-albuminaemic

persons (Bennhold, Peters, and Roth, 1954) in no way suggests that albumin function is selectively unimportant (cf. Cohen, 1965). In fact, in the absence of selective elimination of mutants, much variation in protein structure might be expected. We have no evidence that the structure of human serum albumin is not adaptive; thus the rarity of structural variants may well reflect selective pressure.

### Summary

A genetic and biochemical study of a slowly migrating electrophoretic species of human serum albumin occurring in 22 members of the family of a 7-year-old boy with the nephrotic syndrome is presented. This trait is controlled by a rare co-dominant allele of normal albumin. The published reports are reviewed and the significance of the genetic diversity of serum albumin is discussed.

The author wishes to express his gratitude to Dr. William J. Oliver who brought this family to his attention and in whose laboratory the biochemical determinations were done. He is indebted to Dr. Lowell Weitkamp for determining the phenotype of several of the patients studied. Drs. Frank and Richard Van Skoik of Jackson, Michigan, kindly provided their offices for use while collecting material for this study. Drs. George R. De Muth, William Howatt, and Richard E. Tashian read the manuscript and offered helpful criticism.

### REFERENCES

- Adner, L., and Redfors, A. (1961). En släkt med två albuminfraktioner i serumelektroforesen (bisalbuminaemia). *Nord. Med.*, **65**, 623.
- Ashton, G. C., and Lampkin, E. H. (1965). Serum albumin and transferrin polymorphism in East African cattle. *Nature (Lond.)*, **205**, 209.
- Bennhold, H., Ott, H., and Scheurlen, G. (1958). Beiträge zur Frage der genbedingten Bluteiweissstörungen. *Verh. dtsh. Ges. inn. Med.*, **64**, 279.
- , Peters, H., and Roth, E. (1954). Über einen Fall von kompletter Analbuminaemie ohne wesentliche klinische Krankheitszeichen. *ibid.*, **60**, 630.
- Bergstrand, C. G., and Czar, B. (1957). Paper electrophoretic study of human foetal serum proteins with demonstration of a new protein fraction. *Scand. J. clin. Lab. Invest.*, **9**, 277.
- Braend, M., Efremov, G., Fagerhol, M. K., and Hartmann, O. (1965). Albumin and transferrin variants in Norwegians. *Hereditas (Lund)*, **53**, 137.
- Cohen, B. L. (1965). Paucity of albumin variants in man. *Nature (Lond.)*, **207**, 1109.
- Earle, D. P., Hutt, M. P., Schmid, K., and Gitlin, D. (1959). Observations on double albumin: a genetically transmitted serum protein anomaly. *J. clin. Invest.*, **38**, 1412.
- Efremov, G., and Braend, M. (1964). Serum albumin: polymorphism in man. *Science*, **146**, 1679.
- Franglen, G., Martin, N. H., Hargreaves, T., Smith, M. J. H., and Williams, D. I. (1960). Bisalbuminaemia: an hereditary albumin abnormality. *Lancet*, **1**, 307.
- Gitlin, D., Schmid, K., Earle, D. P., and Givelber, H. (1961). Observations on double albumin. II. A peptide difference between two genetically determined human serum albumins. *J. clin. Invest.*, **40**, 820.
- Goodman, M. (1962). Evolution of the immunologic species specificity of human serum proteins. *Hum. Biol.* **34**, 104.

- Haley, L. E. (1965). Serum albumin polymorphism in quail and chicken-quail hybrids. *Genetics*, **51**, 983.
- Knedel, M. (1957). Die Doppel-Albuminämie, eine neue erbliche Proteinanomalie. *Blut*, **3**, 129.
- (1958). Über eine neue vererbte Protein-Anomalie. *Clin. chim. Acta*, **3**, 72.
- McIndoe, W. M. (1962). Occurrence of two plasma albumins in the domestic fowl. *Nature (Lond.)*, **195**, 353.
- Miescher, F. (1960). Neues Vorkommen der vererbaren Doppel-Albuminämie. *Schweiz. med. Wschr.*, **90**, 1273.
- Nennstiel, H. J., and Becht, T. (1957). Über das erbliche Auftreten einer Albumin-spaltung im Elektrophoresediagramm. *Klin. Wschr.*, **35**, 689.
- Quinteros, I. R., Stevens, R. W. C., Stormont, C., and Asmundson, V. S. (1964). Albumin phenotypes in turkeys. *Genetics*, **50**, 579.
- Robbins, J. L., Hill, G. A., Marcus, S., and Carlquist, J. H. (1963). Paralbuminemia: paper and cellulose acetate electrophoresis and preliminary immunoelectrophoretic analysis. *J. Lab. clin. Med.*, **62**, 753.
- Scheidegger, J. J. (1955). Une micro-méthode de l'immuno-électrophorèse. *Int. Arch. Allergy*, **7**, 103.
- Scheurlen, P. G. (1955). Über Serumweisssveränderungen beim Diabetes Mellitus. *Klin. Wschr.*, **33**, 198.
- Smithies, O. (1955). Zone electrophoresis in starch gels: group variations in the serum proteins of normal human adults. *Biochem. J.*, **61**, 629.
- Stormont, C., and Suzuki, Y. (1963). Genetic control of albumin phenotypes in horses. *Proc. Soc. exp. Biol. (N.Y.)*, **114**, 673.
- Wieme, R. J. (1960). On the presence of two albumins in certain normal human sera and its genetic determination. *Clin. chim. Acta*, **5**, 443.