

# Service experience using DNA analysis for genetic prediction in Duchenne muscular dystrophy

J GOODSHIP, S MALCOLM, M E ROBERTSON, AND M E PEMBREY

From the Mothercare Department of Paediatric Genetics, Institute of Child Health, 30 Guilford Street, London WC1N 1EH.

**SUMMARY** In August 1985 we instituted a carrier and prenatal testing service for Duchenne muscular dystrophy (DMD) using direct DNA analysis. The experience over the first nine months is described.

We have analysed samples for RFLPs from 154 people including 53 women at risk of being DMD carriers from 37 families. We used the probes pERT87-8 (*Bst*XI and *Taq*I polymorphisms), 87-15 (*Taq*I polymorphism), and pXJ1-1 (*Taq*I polymorphism). Forty-one of the women have had their risks altered. We found one deletion (pERT87-8) out of 23 DNA samples analysed from affected boys. We used a recombination fraction of 0.05 in risk calculations but did not detect any known crossovers. In nine of the families there is only an isolated case of DMD. In families where we have not been able to alter the risk of the women being a carrier (for example, because all brothers are dead), we have offered prenatal exclusion and have carried out one first trimester prenatal diagnosis on this basis. Lowering the risk of an affected fetus to <2.5% appears to be a satisfactory situation for many (most) of the women involved and seems to justify the introduction of genetic prediction based on single intragenic probes despite the 5% recombination frequency.

Polymorphic DNA segments linked to DMD were reported some years ago<sup>1</sup> and these served to confirm the localisation of the DMD locus to Xp21.

Recently two different but more direct approaches have been used to isolate the region of the X chromosome carrying the gene. One approach produced clones of sequences deleted in a boy with DMD and a visible chromosomal deletion of the region Xp21.<sup>2</sup> These clones, the pERT series, show several high frequency polymorphisms. It appears that they recombine with DMD mutations in about 5% of cases and, since the work reported here was completed, empirical data supporting this figure have been reported by Fischbeck *et al.*<sup>3</sup> and Walker *et al.*<sup>4</sup> A second approach has been to isolate sequences (pXJ1-1) spanning the chromosomal breakpoint in a girl affected by DMD who carries an X;21 balanced chromosomal translocation.<sup>5</sup> This probe also appears to recombine with the disease locus at a level of 5%. The information that is now available from deletions causing DMD<sup>6</sup> and long range restriction mapping<sup>7</sup> suggests an exceptionally large and complex gene or gene cluster, possibly over 1000 kb in size. Both the pERT and XJ1-1

probes have been shown to be deleted in about 7% of males with DMD and two males (1.4%) with Becker muscular dystrophy have been shown to be missing pERT87-8.<sup>6</sup> These observations, together with the recent isolation of candidate cDNAs for the Duchenne muscular dystrophy gene,<sup>8</sup> indicate that the pERT and XJ1-1 probes are intragenic. A sequence from within the pERT locus has been isolated which hybridises to a large mRNA transcript from human fetal skeletal muscle. A partial cDNA, which corresponds to only 10% of the mRNA, hybridises to eight small exons that span 130 kb. This implies that the total structural gene could span 1000 to 2000 kb.

Our experience with these intragenic probes is reported here. In August 1985 we began what was strictly a clinical service combining pedigree information, creatine kinase (CK) estimations on females at risk,<sup>9</sup> and gene tracking data using first the pERT series of DNA probes and later adding the XJ1-1 probe.

## Materials and methods

### SAMPLE COLLECTION

Where possible 20 ml of blood was collected into

EDTA tubes. In families where there was a clear previous family history, blood samples were collected from the consultand, both parents, and either two brothers or a brother and the maternal grandfather, wherever possible. Whenever there was a living affected male relative blood was taken from him to check whether the disease was running with a deletion of the probe in that family.

In families where the possibility of a new mutation had to be considered, blood was taken from the consultand, both parents, and normal and affected brothers. In all cases where the consultands were over the age of 16 and not pregnant, creatine kinase was measured on three occasions and the carrier:non-carrier probability determined from a standard curve.<sup>9</sup> In addition the mother's CK carrier:non-carrier ratio was taken into consideration when she was not an obligate carrier.

#### PROBES USED

pERT probes were kindly provided by Dr L Kunkel. pERT87-8 recognises a *Bst*XI polymorphism with bands of 4.4 kb and 2.2 kb and a *Taq*I polymorphism with bands of 3.9 kb and 2.8 kb.

pERT87-15 recognises a *Taq*I polymorphism with band sizes 3.3 kb and 3.1 kb. pXJ1.1 was a generous gift from Dr R Worton. It identifies a *Taq*I polymorphism with band sizes 3.8 kb and 3.1 kb.

#### ANALYSIS OF RESTRICTION FRAGMENT LENGTH POLYMORPHISMS

Standard techniques of DNA preparation, gel electrophoresis, and hybridisation were used.<sup>10</sup>

#### RISK CALCULATION

Calculations to determine carrier risk included information from DNA analysis (assuming a 5% recombination fraction for each probe), information derived from the pedigree, and information on creatine kinase levels in all relevant females. These figures were combined using Bayes's theorem, in the way that was used for genetic prediction in haemophilia A and described in detail elsewhere.<sup>11</sup>

#### Results

##### INFORMATIVENESS OF PROBES

Carrier status was clarified in 41 of the first 53 consultands referred to the unit for RFLP analysis. The *Bst*XI polymorphism of pERT87-8, the *Taq*I polymorphism of pERT87-15, and the *Taq*I polymorphism of pXJ1.1 have all been very useful. The *Taq*I polymorphism of 87-8 has been less useful.

##### CARRIER RISK

Fig 1 presents the carrier risk of the women in the study before and after DNA analysis. In 16 of these consultands the risk of being a carrier was lowered to 2.5% or less. In addition, two of the pregnant consultands cancelled planned prenatal tests because their carrier risk was lowered to 4.5% and 6.3% respectively. At least 18 out of the 41 women are therefore unlikely to consider prenatal tests and termination of future pregnancies.

In 12 women referred it was not possible to clarify their carrier risk. In five women this was because their families were uninformative for the poly-

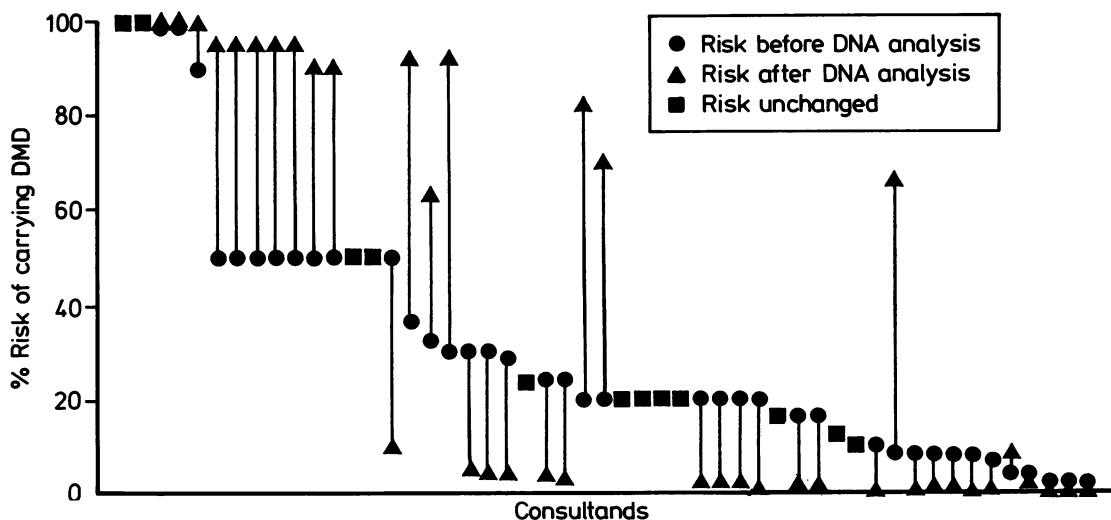

FIG 1 The percentage risk of each woman in the study being a carrier for Duchenne muscular dystrophy before and after DNA analysis.

morphisms we were using. However, in seven consultands the risk could not be clarified because key members of the family had died or were unavailable (brothers, father, or grandparents).

Before DNA studies five women already had a carrier risk of >90% because of abnormally high CK values. In each case this risk was confirmed by DNA studies and subsequently we have sometimes used DNA data from such women to confirm assignment of phase in their families.

Ten women (fig 1) had carrier risks of 50% before DNA analysis. In several cases no CK data were available and the woman was the daughter of an obligate carrier. In the other cases CK data were not helpful. In only two cases was it impossible to modify carrier risk and in both cases this was because crucial family members were unavailable (in one case three affected brothers were dead). One girl had her risk lowered to 9.5% (using a recombination fraction 0.05) in the calculation, even though this was a family in which a deletion was segregating. The others all had their risks raised to 90.5% or 95% depending on how many family members were available to confirm phase.

The largest group (19 women) started with risks of between 20% and 49%. Ten had their risks lowered to 6.3% or less. In five cases it was not possible to modify the risk because no heterozygosity of an RFLP could be found for the key women in the family. In another four cases risks were raised to very high values (70, 82.6, 92, and 92.5%). In three of the cases the factor lowering risk below 50% was a CK carrier:non-carrier (C:NC) ratio of 1:4 and therefore it is anticipated that one in five women within these CK ranges will in fact be carriers. In the fourth case where no CK values were available the woman's prior risk had been lowered below 50% because she already had an unaffected son.

In the final category (<19% prior risk), as expected, most women's risk was lowered to under 2%. In three (of 17) it was not possible to change the risk. In two cases the risk was raised. In one of these there was only a single affected boy in the family (see section on sporadic cases). In the remaining case the risk had been lowered by CK values giving a C:NC ratio of 1:5. Therefore, it is not clear whether this could be a crossover.

#### PRENATAL DIAGNOSIS/EXCLUSION

In the cases of the 32 consultands who were left with a carrier risk of >2.5%, careful consideration was given as to what options for prenatal assessment could be offered during pregnancy. The best available option until the arrival of DNA probes has been fetal sexing by chorion villus sampling (CVS) followed by early termination of all male fetuses.

We have found that DNA analysis can improve this situation (that is, lessen the risk of normal males being terminated) particularly by using prenatal exclusion.

In these women the DNA was analysed to find a probe RFLP for which they were heterozygous and where either their mother was homozygous or DNA was available from both parents. In this situation all of the consultand's risk is carried on the allele she has inherited from her mother (provided the consultand has an affected relative other than her own son). Considering the possibility of a recombination at meiosis, a male fetus inheriting her paternal RFLP allele has a low risk of being affected (recombination fraction  $\times$  her carrier risk) and the risk of a male fetus carrying her maternal RFLP allele being affected approaches her own risk of being a carrier.

Where the consultand's risk of being a carrier is 20% or less a male offspring carrying her paternal allele has a 1% or less risk of being affected. Where the consultand's carrier risk is between 20% and 100% the risk of a male fetus who receives the paternal allele being affected ranges from 1% to 5%.

This approach has been useful in a number of different clinical situations.

#### Example 1 (fig 2)

The simplest situation is demonstrated by the following family. The pregnant consultand was referred for clarification of her carrier status. Her mother was homozygous for the pERT probe polymorphisms. Her risk of being a carrier based on pedigree and CK data was 7.6%. A male fetus inheriting the 2.2 kb band had a 0.3% probability of having DMD but a male fetus with the 4.2 kb band had a 7.3% probability of having the disease. The consultand had planned to have fetal sexing and termination of males, but given this option asked us to test not only the sex of the fetus but also its RFLP

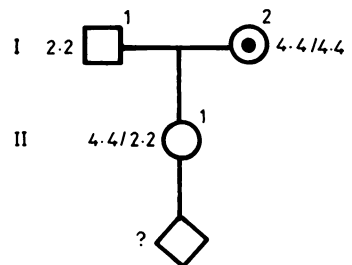

FIG 2 A pedigree in which II.1 sought prenatal exclusion of DMD in her fetus. The *Bst*XI restriction fragments 4.4 kb and 2.2 kb detected by pERT87-8 are shown (see text).

genotype. In the event her fetus was female. Since then the XJ1-1 probe has become available and her carrier risk has been lowered to 0.6%

#### Example 2 (fig 3)

When all the affected males have died and there are no normal brothers, even if the mother is heterozygous it is impossible to establish phase unless the maternal grandparents are alive, and even then it may not be possible if the mother could represent a new mutation. This was the case in example 2.

The proband's carrier risk on pedigree and CK grounds was 50%. She had had a termination of a male fetus at 18 weeks' gestation two years earlier. The fetus was shown to be a male carrying the (lower) band after chorion villus sampling and therefore had a 2.5% risk of being affected by Duchenne muscular dystrophy. She has decided to continue the pregnancy.

#### Example 3 (fig 4)

In the family illustrated in fig 4, the consultand's father was unavailable. She and her mother were heterozygous for both the *Bst*XI and the *Taq*I polymorphisms of pERT87-8. Although phase in the mother was known with considerable certainty from her two normal sons, in this particular situation, where both mother and daughter are heterozygous, it is impossible to tell which of the mother's chromosomes has been inherited by the daughter in the absence of the father. Therefore, her risk could not be clarified. Using the *Taq*I polymorphism of XJ1-1, however, her mother was homozygous and she was heterozygous and so prenatal exclusion could be offered.

The same situation has arisen in the case of a girl who was adopted where we were able to obtain a sample of blood for DNA extraction from her mother but not from her father.

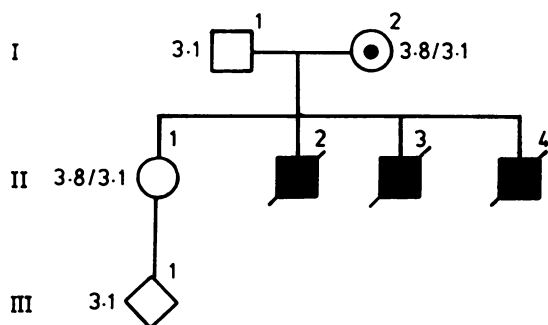

FIG 3 A pedigree in which II.1 sought prenatal exclusion of DMD in her fetus. The *Taq*I restriction fragments 3.8 kb and 3.1 kb detected by pXJ1-1 are shown (see text).

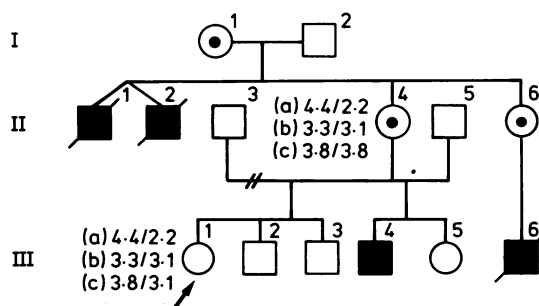

FIG 4 A pedigree in which III.1 sought clarification of her carrier status. (a) The *Bst*XI restriction fragments 4.4 kb and 2.2 kb, detected by pERT87-8. (b) The *Taq*I restriction fragments 3.3 kb and 3.1 kb, detected by pERT87-15. (c) The *Taq*I restriction fragments 3.8 kb and 3.1 kb detected by pXJ1-1. The results in III.2 and III.3 which gave phase in II.4 are not shown. Prenatal exclusion can be offered to III.1 using pXJ1-1, but her carrier status has not been clarified due to the absence of II.3. Ideally, analysis of the affected subject III.4 with pXJ1-1 should be performed to exclude the unlikely possibility of a deletion confined to the pXJ1-1 sequence, but this has proved impossible for family reasons.

#### Sporadic cases

Twelve of the 53 consultands investigated have been from families with a sporadic case of Duchenne muscular dystrophy and where the mother's creatine kinase fell within the normal range. In 11 of these cases the girl inherited the opposite RFLP allele from her affected brother, lowering her risk considerably. One consultand received the same RFLP allele as her affected brother, raising her carrier risk from 4% to 8%. She has opted to have prenatal exclusion if she becomes pregnant.

#### Discussion

We have reported our experience of using a limited number of DNA probes for genetic prediction in DMD families for the period August 1985 to May 1986. Our department does not have a research programme on the linkage relationship of the many sequences around Xp21 and these analyses were introduced purely as a clinical service. As such they represent what can be achieved using the simplest strategy of gene tracking with single, closely linked probes, the probabilities being calculated on the reported pooled recombination frequency observed in DMD families.

We selected the pERT87 probes initially, and later added the XJ1-1 probe because deletion and linkage data suggested that these were closest to the DMD mutation<sup>7,5</sup> and the strategies used to clone

these sequences were likely to yield gene specific clones. The recent isolation of a sequence from within the pERT87 locus that hybridises to a large mRNA transcript from human fetal muscle supports this view.<sup>8</sup>

While we were early proponents of the use of loosely linked flanking DNA markers in DMD families for genetic prediction,<sup>12</sup> by August 1985 the situation was confused. There was evidence of non-overlapping deletions associated with the DMD mutation in different families<sup>6</sup> and a significant number of recombinations between the DMD mutation and the pERT probes,<sup>3</sup> observations that suggested that the DMD locus was very large and possibly a recombination hot spot. Predictions based on loosely linked flanking probes assume that gene conversion or localised double crossover events within the DMD locus would be rare, an assumption that we felt could not be made until more was known about the locus. While no recombination between flanking probes must increase the reliability of the prediction, it is still not certain by how much. If a recombination with a flanking probe is found, then no prediction would be made on the grounds that the recombination may have occurred between the pERT or XJ1.1 locus and the DMD mutation. About 15% of cases would be expected to fall into this category and Bakker *et al.*,<sup>13</sup> in perhaps the largest systematic series using flanking markers to date, found a comparable figure. They reported that 17 of 136 (12.5%) women could be given no conclusive statement on carrier risk because of a detected recombination between the nearest informative bridging markers. While believing that the use of single linked probes is only a passing phase in genetic prediction in DMD families, the series reported here nevertheless indicates that this approach can be extremely useful in clarifying carrier status.

In eight cases we have found that we have used one probe to determine a consultand's carrier status but she has been homozygous for that probe and has a carrier risk of >2.5%. In all these cases the consultand has been heterozygous for another probe which could be used for prenatal exclusion if necessary. This shows that one often has to investigate the family for several polymorphisms in order to offer a service.

Twelve women were shown to have risks of >90% of being DMD carriers. They could be offered first trimester prenatal diagnosis but there would still be a 5% risk of an 'unaffected' male being affected which might be unacceptable to the family. In the only such pregnancy analysed by us, the woman decided eventually against any form of prenatal diagnosis and sadly has had an affected son.

In the group of women whose prior risk fell between 20% and 49% the women fell into three groups. (1) In five cases the risk could not be altered with the probes used. Three of these women have subsequently become pregnant and requested prenatal exclusion. (2) In 10 cases the risk was lowered to <6.3%. Three of these women cancelled prenatal tests for fetal sexing already arranged. (3) In the other four cases the risk was substantially raised. None of these women has so far become pregnant.

In the group who started with a risk <19% only one had her risk raised above 19% and 12 had their risk reduced to 2% or less.

The use of pERT and XJ1.1 probes clearly provides an efficient method of supplementing pedigree analysis and CK estimations in clarifying carrier status. For many women, anxiety is reduced and in the end unaffected male fetuses are saved, because for some women the alternative would have been fetal sexing and termination of all males in the absence of the gene tracking data. Prenatal exclusion, where the residual risk after an 'exclusion' is acceptably low, also saves half the males. The great limitation of the present strategy is the residual risk of about 5% (the recombination frequency) when prenatal diagnosis is considered for women who are known to be carriers.

The size and complexity of the DMD locus provides a real challenge in devising a clinical service strategy that gives acceptable reliability without being prohibitively expensive in labour costs and leaving a significant proportion of families with ambiguous results. A combination of intragenic probes spanning the whole locus, plus some immediately distal and proximal to the gene, may be required.

We gratefully acknowledge the financial support of the DHSS (Special Medical Development). We are indebted to Dr Lou Kunkel for releasing the pERT probes to us and to Dr Ron Worton for the XJ1.1 probe. We would like to thank Dr Robin Winter for advice on calculations, Claire Walker (Muscular Dystrophy Group of Great Britain) for help in approaching some families, and the obstetricians who performed the chorionic villus sampling. We thank Mrs Melanie Barham for administrative and secretarial help.

#### References

- <sup>1</sup> Davies KE, Pearson PL, Harper PS, *et al.* Linkage analysis of two cloned DNA sequences flanking the Duchenne muscular dystrophy locus on the short arm of the human X chromosome. *Nucleic Acids Res* 1983;11:2303-12.
- <sup>2</sup> Monaco AP, Bertelson CJ, Middlesworth W, *et al.* Detection of deletions spanning the Duchenne muscular dystrophy locus using a tightly linked DNA segment. *Nature* 1985;316:842-5.

- <sup>3</sup> Fischbeck KH, Ritter AW, Tirschwell DL, *et al.* Recombination with pERT87 (DXS164) in families with X-linked muscular dystrophy. *Lancet* 1986;ii:104.
- <sup>4</sup> Walker A, Hart K, Cole C, *et al.* Linkage studies in Duchenne and Becker muscular dystrophies. *J Med Genet* 1986;23:538-47.
- <sup>5</sup> Ray PN, Belfall B, Duff C, *et al.* Cloning of the breakpoint of an X:21 translocation associated with Duchenne muscular dystrophy. *Nature* 1985;318:672-5.
- <sup>6</sup> Kunkel LM, Hejtmancik JF, Caskey CT, *et al.* Analysis of deletions in DNA from patients with Becker and Duchenne muscular dystrophy. *Nature* 1986;322:73-7.
- <sup>7</sup> Burmeister M, Lehrach H. Long-range restriction map around the Duchenne muscular dystrophy gene. *Nature* 1986;324:582-5.
- <sup>8</sup> Monaco AP, Neve RL, Colletti-Feener C, *et al.* Isolation of candidate cDNAs for portions of the Duchenne muscular dystrophy gene. *Nature* 1986;323:646-50.
- <sup>9</sup> Dennis NR, Evans K, Clayton B, Carter CO. Use of creatine kinase for detecting severe X-linked muscular dystrophy carriers. *Br Med J* 1976;2:577-9.
- <sup>10</sup> Old JM. Fetal DNA analysis. In: Davies KE, ed. *Human genetic diseases: a practical approach*. Washington: IRL Press, 1986:1-16.
- <sup>11</sup> Winter RM, Harper K, Goldman E, *et al.* First trimester prenatal diagnosis and detection of carriers of haemophilia A using the linked DNA probe DX13. *Br Med J* 1985;291:765-9.
- <sup>12</sup> Pembrey ME, Davies KE, Winter RM, *et al.* Clinical use of DNA markers linked to the gene for Duchenne muscular dystrophy. *Arch Dis Child* 1984;59:208-16.
- <sup>13</sup> Bakker E, Bonten EJ, de Lange LF, *et al.* DNA probe analysis for carrier detection and prenatal diagnosis of Duchenne muscular dystrophy: a standard diagnostic procedure. *J Med Genet* 1986;23:573-80.

Correspondence and requests for reprints to Dr J Goodship, Mothercare Department of Paediatric Genetics, Institute of Child Health, 30 Guilford Street, London WC1N 1EH.