

# X linked neonatal myotubular myopathy: one recombination detected with four polymorphic DNA markers from Xq28

A-E Lehesjoki, E-M Sankila, J Miao, M Somer, R Salonen, J Rapola, A de la Chapelle

## Abstract

**A three generation family with X linked myotubular myopathy (MTM1) was studied with several polymorphic markers from the distal long arm of the X chromosome. A recombination between the disease gene and four markers (loci DXS52, DXS134, DXS15, F8C) from the Xq28 cluster was detected. A new polymorphic marker (U6.2) defining the locus DXS304 in the Xq27-28 region proximal to the Xq28 cluster did not show any recombination with MTM1. These results suggest the following order of loci in distal Xq: cen-DXS42-DXS105-(DXS304, MTM1)-(DXS52, DXS134, DXS15, F8C)-tel.**

Neonatal X linked myotubular myopathy (MTM1; MIM 31040) is a disorder characterised by severe hypotonia and respiratory failure. Affected boys usually die in the neonatal period. On histological examination the muscles show small, rounded fibres, resembling myotubes, with centrally located nuclei.<sup>1,2</sup> Previous DNA studies have shown evidence for linkage between X linked myotubular myopathy and DXS52 with a maximum lod score of 5.12 at a

recombination fraction of 0.00.<sup>3,4</sup> We report here one recombination with DXS52 and three other polymorphic DNA markers from Xq28, and suggest the following order of loci: cen-DXS42-DXS105-(DXS304, MTM1)-(DXS52, DXS134, DXS15, F8C)-tel.

## Case reports

The pedigree of the three generation family studied is shown in fig 1.

### CASE III.2

The second child of the family was born at term after a pregnancy complicated by polyhydramnios. The birth weight was 3000 g and the length 54 cm. The Apgar scores were 6 at one minute and 6 at 15 minutes. The child was hypotonic and cyanotic and had petechiae but normal thrombocytes. He was treated with antibiotics for suspected intrauterine infection. A simian crease in the right hand and micrognathia were noted. The child died of respiratory failure at the age of 6 days. Necropsy showed diffuse pneumonia and small haemorrhagic lesions in the brain. Specimens from muscle were not obtained.

### CASE III.3

During the third pregnancy the mother experienced abnormally weak fetal movements and the pregnancy was complicated by polyhydramnios. The son was born at 38 weeks of pregnancy, with a birth weight of 3300 g and a length of 54 cm. The Apgar scores were 5 at one minute and 6 at five minutes. The child was hypotonic and needed artificial ventilation for the first two weeks of life. He also had truncal petechiae and mild dysmorphism, micrognathia, a high nasal bridge, and ptosis.

The hypotonia persisted, deep tendon reflexes could not be elicited, and flexion contractures of the hip and knee joints started to develop. A slightly raised level of serum creatine kinase was found. The electromyogram (EMG) was normal. A muscle biopsy at the age of 3 weeks showed rounded fibres 7.5 to

---

Department of Medical Genetics, University of Helsinki, Haartmaninkatu 3, 00290 Helsinki, Finland.

A-E Lehesjoki, E-M Sankila, J Miao, A de la Chapelle

Department of Medical Genetics, The Population and Family Welfare Federation, Helsinki, Finland.

M Somer

Laboratory of Prenatal Genetics, Department of Obstetrics and Gynecology, Helsinki University Central Hospital, Finland.

R Salonen

Department of Pathology, University of Helsinki, Finland.

J Rapola

Correspondence to Dr Lehesjoki.

15 µm in diameter. In 30% of the fibres the nuclei were centrally located. An 'empty' area in the middle of several fibres was evident. The histological diagnosis was consistent with congenital myotubular myopathy. The child died at the age of 6 weeks. Necropsy showed numerous small calcified lesions in the brain. The histological findings in the necropsy specimens were similar to those of the muscle biopsy.

CASE III.8

The maternal cousin of cases III.2 and III.3 was born at 39 weeks. His birth weight was 2770 g and length 50 cm. There was polyhydramnios. The child was asphyxiated and Apgar scores were 1 at one minute, 4 at five minutes, and 5 at 10 minutes. His breathing was feeble and artificial ventilation was needed for three weeks. He was hypotonic, but had some

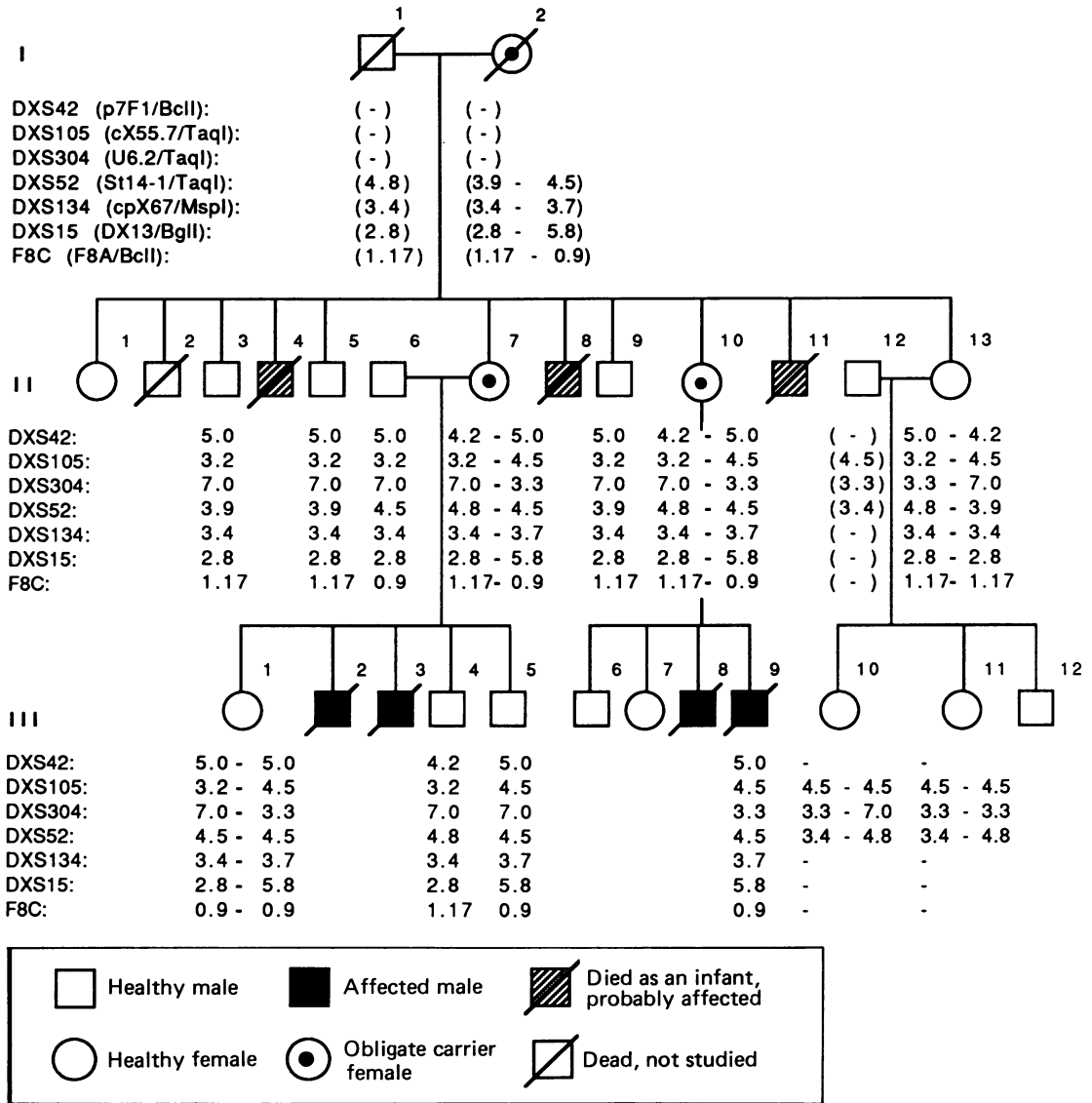
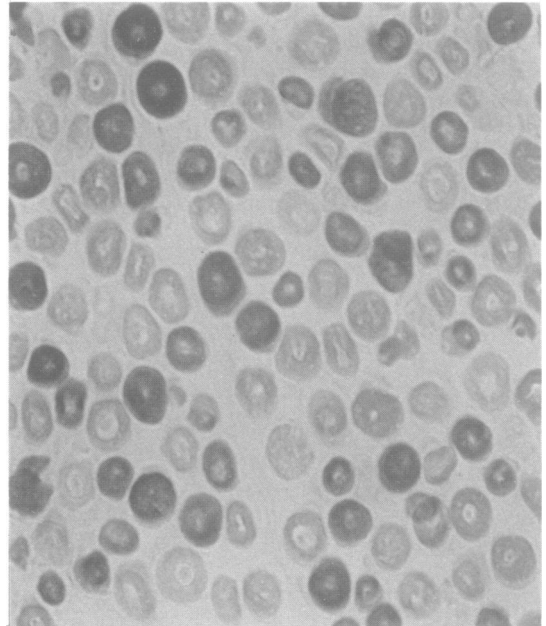

Figure 1 Pedigree of the Finnish three generation family with myotubular myopathy. The informative loci and the respective DNA probes and enzymes are shown. The allelic fragments (length in kb) are depicted under each subject studied. Numbers in parentheses indicate deduced alleles.

movement distally in his extremities. The deep tendon reflexes were absent. He had a myopathic facies and a high palate. The EMG showed mild hypotonic changes. The serum creatine kinase level was normal. A muscle biopsy at the age of 5 days showed similar, small, rounded fibres as in case III.3. Nearly all fibres had central nuclei. The transversally cut fibres without a visible nucleus had a central non-stained area that gave an appearance of a ring or a tubulus (fig 2). His weight gain was poor and he died of respiratory failure at the age of 8 weeks.

#### CASE III.9

The brother of case III.8 was born at term. The birth weight was 3480 g and length 52 cm. There was polyhydramnios. Apgar scores were 3 at one minute, 3 at five minutes, and 6 at 10 minutes. He failed to breathe and had artificial ventilation for six days. He had more strength in his muscles than his affected brother. The muscles did not seem hypoplastic, but felt firm. The histology of a muscle biopsy was identical to that of case III.8. Enzyme histochemical staining showed a predominance of fibres with type I staining and the tubular appearance of the fibres was very clear (fig 3). The patient also had difficulty in swallowing. Mentally he appeared to develop normally. He died at the age of 5 months.



*Figure 3 Muscle histology of case III.9. Adenosine triphosphatase staining (pH 9.4) gives tubular appearance. Note predominance of the pale stained fibres indicating type I differentiation.*

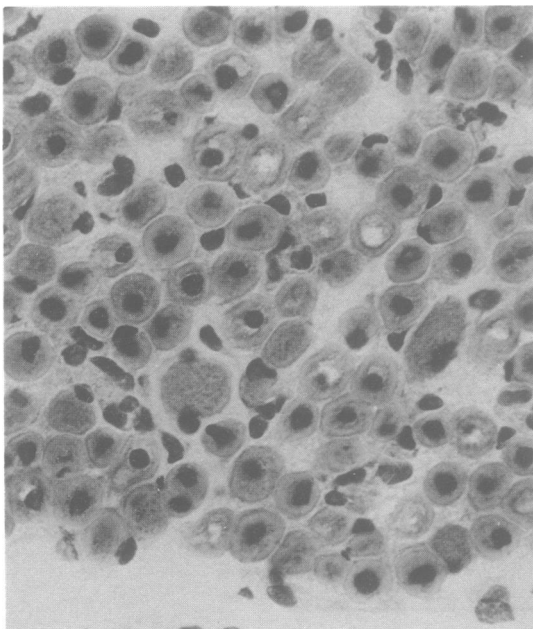

*Figure 2 Muscle histology of case III.8. Small rounded fibres show centrally placed nuclei. Note also 'tubular' fibres. (H and E.)*

#### Family history

The grandmother (I.2) had 15 sibs. Of her six brothers, four had died at the ages of 1 to 12 days. She had four daughters and seven sons, three of whom (II.4, II.8, and II.11) had died at the ages of 1 to 29 days. The cause of death of these children is not known. Two obligate carriers (II.7 and II.10) had three and five early spontaneous abortions, respectively. Muscle biopsies of these two obligate carriers and one of their sisters (II.13) were investigated. No pathological changes were found.

#### Linkage analysis

The polymorphic DNA markers and enzymes used in the RFLP analyses are shown in fig 1. The allelic fragment lengths (in kb) are also shown. Three additional markers from distal Xq (*F9*, *DXS10*, *DXS11*) were uninformative. The pairwise linkage analyses were carried out using the program ILINK and the multilocus analysis using the program LINKMAP from the LINKAGE computer program package (LINKAGE ver 4.7, courtesy of Howard Hughes Medical Institute). The results of the pairwise linkage analyses are shown in the table.

Among seven informative meioses one recombination between the disease locus and four polymorphic

Lod scores at different values of recombination fraction ( $\theta$ ) between *MTM1* and marker loci. The maximum lod scores ( $Z[\theta \text{ max}]$ ) at the maximum recombination fraction ( $\theta \text{ max}$ ) are also shown.

Locus	Z ( $\theta$ max)	$\theta$ max	0.000	0.001	0.010	0.050	0.100	0.150	0.200	0.300	0.400
<i>DXS42</i>	0.07	0.33	∞	-2.11	-1.12	-0.45	-0.19	-0.06	0.01	0.07	0.06
<i>DXS105</i>	0.07	0.67	∞	-2.42	-1.44	-0.82	-0.60	-0.48	-0.39	-0.23	-0.10
<i>DXS304</i>	0.59	0.00	0.59	0.58	0.55	0.41	0.22	0.03	-0.15	-0.36	-0.24
<i>DXS52</i>	0.80	0.13	∞	-0.90	0.08	0.65	0.79	0.79	0.73	0.51	0.21
<i>DXS134</i>	0.80	0.13	∞	-0.90	0.08	0.65	0.79	0.79	0.73	0.51	0.21
<i>DXS15</i>	0.80	0.13	∞	-0.90	0.08	0.65	0.79	0.79	0.73	0.51	0.21
<i>F8C</i>	0.80	0.13	∞	-0.90	0.08	0.65	0.79	0.79	0.73	0.51	0.21

loci from the Xq28 cluster (loci *DXS52*, *DXS134*, *DXS15*, *F8C*) had occurred in the meiosis leading to III.5. The maximum lod score for linkage between these four loci and the *MTM1* locus was 0.80 at a recombination fraction of 0.13. A new polymorphic DNA marker (U6.2) defining the locus *DXS304* in the Xq27-28 region proximal to the Xq28 cluster<sup>5,6</sup> did not show any recombination with *MTM1*. Unfortunately, the allelic fragments of the dead grandparents (I.1 and I.2) could not be deduced from the RFLP alleles of their offspring and only three meioses could be analysed. The maximum lod score for linkage between *DXS304* and *MTM1* was 0.58 at a recombination fraction of 0.00. With the two more proximal markers (*DXS42* and *DXS105*) one recombination in three meioses was observed.

The location of the *MTM1* gene was estimated using the LINKMAP program applying the method of location scores. The order of the marker loci was assumed to be fixed, *DXS105-DXS304-DXS52*, and the location of the *MTM1* locus was allowed to vary. The peak location score was found with the order *DXS105-(MTM1, DXS304)-DXS52* (data not shown). The odds in favour of this order compared to the order *DXS105-DXS304-DXS52-MTM1* were 9:1.

## Discussion

The identical clinical course of the four patients with typical dysmorphism and muscle biopsy findings,<sup>1,2</sup> together with the family history, is compatible with X linked neonatal myotubular myopathy. Moreover, the several neonatal deaths of males in previous generations support the diagnosis. In this family the disease seems to be lethal even with current intensive care of the newborn.

Previous studies have suggested linkage of *MTM1* to Xq28 marker loci, but have failed to localise the gene further in this region.<sup>3,4</sup> No recombinations between *MTM1* and locus *DXS52* have been detected with a combined maximum lod score of 5.12. Our linkage analysis showed a maximum lod score of 0.80 at a recombination fraction of 0.13 owing to one recombination between *MTM1* and *DXS52*. Considering linkage results obtained by others,<sup>3,4</sup> the true recombination fraction is likely to be much closer to 0 than 0.13. In order to determine the orientation of the

*MTM1* locus in relation to the Xq28 marker loci, we analysed several adjacent RFLPs. Three loci were informative: *DXS105* and *DXS42* recombined with *MTM1*, whereas *DXS304* did not. The order of loci compatible with the smallest number of crossovers is: cen-*DXS42-DXS105-(DXS304,MTM1)-(DXS52, DXS134, DXS15, F8C)*-tel. It must also be noted that this order of loci depends entirely on subject III.5 and it cannot be ruled out that he is a double recombinant for *DXS304*. Moreover, when multilocus analysis is applied, the suggested location is only nine times more likely than the location of *MTM1* distal to *DXS52*.

Our data are consistent with the previous assignment of *MTM1* to Xq28. However, no firm conclusions can be reached based on data from one family only. It is obvious that further analysis of additional families and DNA markers is needed to map the disease locus more precisely. In mapping this gene, where data from several research groups have to be combined, the importance of accurate clinical diagnosis cannot be overemphasised.

We wish to thank Dr R Lawn for probe F8A, Dr K Davies for probe DX13, Dr J-L Mandel for probe St14, Dr P Pearson for probes cpX67 and cX55.7, Dr N Dahl for probe U6.2, and Dr R Nussbaum for probe p7F1. We thank Dr L Alanen for valuable cooperation and Dr P Sistonen for kindly performing the computer analyses. Part of this study was done at the Folkhälsan Institute of Genetics. This study was supported by grants from the Academy of Finland and the Sigrid Juselius Foundation.

- Giacola GP, Hale JE. X-linked neonatal myotubular myopathy. *South Med J* 1984;77:1182-5.
- Silver MM, Gilbert JJ, Stewart S, Brabyn D, Jung J. Morphologic and morphometric analysis of muscle in X-linked myotubular myopathy. *Hum Pathol* 1986;17:1167-78.
- Thomas NST, Sarfarazi M, Roberts K, et al. X-linked myotubular myopathy (MTM1): evidence for linkage to Xq28 DNA markers. *Cytogenet Cell Genet* 1987;46:704.
- Darnfors C, Börje Larsson HE, Oldfors A, et al. X-linked myotubular myopathy. A linkage study. *Cytogenet Cell Genet* 1989;51:983.
- Dahl N, Hammarström-Heeroma K, Goonewardena P, et al. Isolation of a DNA probe of potential use for diagnosis of the fragile-X syndrome. *Hum Genet* 1989;82:216-8.
- Dahl N, Malmström H, Hammarström-Heeroma K, et al. Isolation of a new DNA marker tightly linked to the fragile-X locus (FRAXA). *Cytogenet Cell Genet* 1989;51:982.