

Short reports

Usher syndrome type III (USH3) linked to chromosome 3q in an Italian family

P Gasparini, A De Fazio, A I Croce, P Stanziale, L Zelante

Abstract

We report an Italian family affected by Usher type III syndrome. Linkage study, performed using markers corresponding to the Usher loci already mapped, clearly showed linkage with markers on chromosome 3q24-25. Our data further support the presence of an Usher III locus on chromosome 3, as recently reported in a Finnish population.

(J Med Genet 1998;35:666-667)

Keywords: Usher syndrome; deafness; retinitis pigmentosa

Usher syndrome (USH) is an autosomal recessive disorder characterised by deafness and blindness owing to sensorineural hearing loss and progressive pigmentary retinopathy. Usher syndrome is clinically and genetically heterogeneous. Clinically, two major forms of Usher syndrome have been established (USH1 and USH2), one characterised by congenital, severe to profound hearing loss and absence of vestibular function, and a second in which the congenital hearing loss is less severe and vestibular function is normal.¹ A third form (USH3) showing progressive hearing loss has also been proposed.²

Linkage studies have shown genetic heterogeneity in Usher syndrome and five distinct loci have been mapped for USH1 and USH2: 14q (USH1A),³ 11q (USH1B),⁴ 11p (USH1C),⁵ 10q (USH1D),⁶ 1q (USH2A).^{7,8} A sixth locus for Usher syndrome type III (USH3) was assigned to chromosome 3q⁹ and this location was recently narrowed down to an approximately 1 cM interval between markers D3S1299 and D3S3625.¹⁰ Here we report a family from southern Italy in which four members in two generations were diagnosed as affected by Usher type III syndrome.

Case reports

The family was referred for genetic counselling of three sibs with auditory impairment (fig 1). The pedigree also showed a paternal uncle (II.1) affected by blindness and deafness. He was a 42 year old man who was born to consanguineous parents. In early infancy he showed bilateral, progressive, sensorineural hearing loss and at the age of 20 years ocular

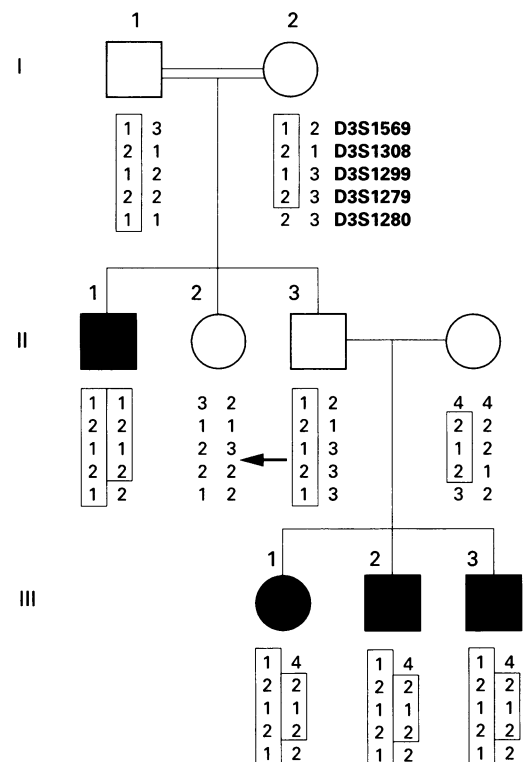

Figure 1 Haplotype analysis using microsatellite markers at chromosome 3q24-25. The affected haplotypes are boxed. The region of homozygosity in the third generation is also clearly indicated. The arrow marks the recombination event in the healthy subject II.2.

findings appeared that were diagnosed as retinitis pigmentosa. The patient is now blind. III.1 is a 23 year old woman with bilateral, progressive, sensorineural hearing loss. Ocular fundus examination showed retinitis pigmentosa and the patient suffers from mild hemeralopia. III.2 is a 20 year old male whose hearing was initially nearly normal but has been progressively deteriorating. At present hearing impairment is moderate to severe. Ocular examination showed typical lesions of retinitis pigmentosa which is still clinically asymptomatic. III.3 is 11 years old and shows moderate hearing loss and a mild form of retinitis pigmentosa on fundus examination. Vestibular function is normal in all patients.

Linkage analysis, results, and discussion

Five microsatellite markers mapping on chromosome 3q23-24, whose order was

Medical Genetics Service, IRCCS-CSS Hospital, I-71013 San Giovanni Rotondo, Italy

P Gasparini
A I Croce
P Stanziale
L Zelante

Department of Ophthalmology, IRCCS-CSS Hospital, San Giovanni Rotondo, Italy
A De Fazio

Correspondence to: Dr Zelante.

Received 21 July 1997
Revised version accepted for publication 26 January 1998

Table 1 Pairwise lod scores between USH3 and chromosome 3

Markers	Lod scores at recombination frequency							Z _{max}	θ _{max}
	0.00	0.01	0.05	0.10	0.20	0.30	0.40		
D3S1569	1.93	1.88	1.71	1.48	1.01	0.55	0.17	1.93	0.00
D3S1308	1.63	1.59	1.43	1.22	0.81	0.41	0.10	1.63	0.00
D3S1299	2.43	2.38	2.15	1.86	1.27	0.68	0.20	2.43	0.00
D3S1279	1.75	1.71	1.54	1.30	0.88	0.46	0.13	1.75	0.00
D3S1280	-∞	0.01	0.55	0.65	0.54	0.30	0.09	0.65	0.00

cen-D3S1569-8 cM-D3S1308-1 cM-D3S1299-2 cM-D3S1279-1 cM-D3S1280-tel, were used for linkage analysis. In addition, a linkage study was also performed limited to the previously described USH regions of chromosomes 14q (USH1A), 11q (USH1B), 11p (USH1C), 10q (USH1D), and 1q (USH2A). In this case, we used the published markers to map these loci by linkage analysis. The markers used were the following: D14S292, D14S78, and D14S6S for chromosome 14q, D11S911 and D11S527 for chromosome 11q, D11S899 for chromosome 11p, D10S529 and D10S202 for chromosome 10q, and D1S229 and D1S490 for chromosome 1q. PCR reactions, carried out as previously described, were performed using fluorescently labelled primers, and run in an ABI PRISM 377 DNA sequencer machine (PE, Foster City, USA). The results were processed by GENESCAN software, and allele assignment was carried out using the GENOTYPER™ software. Linkage analysis was performed using the LINKAGE package program.¹¹

Positive pairwise lod scores were obtained with markers D3S1569 (Z=1.93 at θ=0.00), D3S1308 (Z=1.63 at θ=0.00), D3S1299 (Z=2.43 at θ=0.00), D3S1279 (Z= 1.75 at θ=0.00), and D3S1280 (Z=0.65 at θ=0.10) (table 1). Negative lod scores (less than 2) were obtained with markers corresponding to the other Usher loci tested (data not shown). A recombinational event was observed between markers D3S1299 and D3S1279 in one of the healthy members (II.2) of the family (fig 1). Because of the consanguinity, patient II.1 showed homozygosity with four out of five

markers used, while III.1, III.2, and III.3 inherited identical haplotypes. These sibs also showed homozygosity with markers D3S1308, D3S1299, and D3S1279 probably because of distant consanguinity between their parents who lived in the same small village in southern Italy. In this case, homozygosity will help in defining the USH3 gene region, which is narrowed by markers D3S1569 and D3S1280 located on the same YAC contig (WC318). Our data are in full agreement with those recently published for the Finnish families,^{9, 10} and represent the first description of an USH3 family linked to chromosome 3 in a different population.

Several ESTs and cDNAs have already been mapped within the USH3 region. In particular, a strong candidate (profilin-2G) has already been investigated and excluded.¹⁰ Our work is in progress on other candidate genes.

This work was supported, in part, by the Italian Ministry of Health and Telethon grant E549 (PG).

- 1 Smith RJH, Berlin CI, Heitmancik JF, *et al.* Clinical diagnosis of the Usher syndromes. *Am J Med Genet* 1982;50:32-8.
- 2 Smith RJH, Pelias MZ, Daiger SP, Keats BJB, Kimberling WJ, Heitmancik JF. Clinical variability and genetic heterogeneity within the Acadian Usher population. *Am J Med Genet* 1992;3:964-9.
- 3 Kaplan J, Gerber S, Bonneau D, *et al.* A gene for Usher syndrome type I (USH1A) maps to chromosome 14q. *Genomics* 1992;14:979-87.
- 4 Kimberling WJ, Moller CG, Davemport S, *et al.* Linkage of Usher syndrome type I gene (USH1B) to the long arm of chromosome 11. *Genomics* 1992;14:988-94.
- 5 Smith RJH, Lee EC, Kimberling WJ, *et al.* Localization of two genes for Usher syndrome type I to chromosome 11. *Genomics* 1992;14:995-1002.
- 6 Wayne S, Der Kaloustian UM, Schloss M, *et al.* Localization of the Usher syndrome type ID gene (UshID) to chromosome 10. *Hum Mol Genet* 1996;5:1689-92.
- 7 Kimberling WJ, Weston MD, Moller C, *et al.* Localization of Usher syndrome type II to chromosome 1q. *Genomics* 1990;7:245-9.
- 8 Kimberling WJ, Weston MD, Moller C, *et al.* Gene mapping of Usher syndrome type IIa: localization of the gene to a 2.1-cM segment on chromosome 1q41. *Am J Hum Genet* 1995;56:216-23.
- 9 Sankila EM, Pakarinen L, Kaariainen H, *et al.* Assignment of an Usher syndrome type III (USH3) gene to chromosome 3q. *Hum Mol Genet* 1995;4:93-8.
- 10 Joensuu T, Blanco G, Pakarinen L, *et al.* Refined mapping of the Usher syndrome type III locus on chromosome 3, exclusion of candidate genes, and identification of the putative mouse homologous region. *Genomics* 1996;38:255-63.
- 11 Ott J. *Analysis of human linkage*. 2nd ed. Baltimore: Johns Hopkins University Press, 1992.