

Bilevel Disulfide Group Reduction in the Activation of C₄ Leaf Nicotinamide Adenine Dinucleotide Phosphate-Malate Dehydrogenase

Marshall D. Hatch* and Anthony Agostino

Division of Plant Industry, Commonwealth Scientific and Industrial Research Organization, GPO Box 1600, Canberra, ACT, 2601 Australia

ABSTRACT

The time course of thioredoxin-mediated reductive activation of isolated *Zea mays* nicotinamide adenine dinucleotide phosphate-malate dehydrogenase is highly sigmoidal in nature. We examined the factors affecting these kinetics, including the thiol-disulfide status of unactivated and activated forms of the enzyme. The maximum steady rate of activation was increased, and the length of the lag in activation decreased, as the concentrations of thioredoxin-m, dithiothreitol, and KCl were increased. The lag in activation (sigmoidicity) was eliminated by preincubating the unactivated enzyme with 100 mM 2-mercaptoethanol; this pretreatment did not activate the enzyme. Unactivated nicotinamide adenine dinucleotide phosphate-malate dehydrogenase was found to contain approximately two SH groups per subunit, increasing to about four SH per subunit after pretreatment with 2-mercaptoethanol and six SH per subunit after activation by incubating the enzyme with dithiothreitol. We suggest that reduction of one particular higher redox potential disulfide group in unactivated nicotinamide adenine dinucleotide phosphate-malate dehydrogenase facilitates the subsequent reduction of the critical S-S group (regulatory S-S) necessary to generate the active form of the enzyme.

NADP-MDH¹ catalyzes a key reaction in the primary path of carbon assimilation of NADP-malic enzyme-type C₄ species (12). In C₄ plants, and also in C₃ plants, this enzyme is rapidly inactivated in darkened leaves by a process involving formation of disulfide bonds; it is reactivated in the light by reductive cleavage of disulfide bonds to form thiol groups (9). In vivo, these oxidation and reduction processes are apparently mediated by a particular thioredoxin termed ThR-m; the redox state of ThR-m is in turn linked to the redox state of the photosynthetic electron transport system through its reaction with ferredoxin (5, 9).

Analyses of the thiol content of active and unactivated forms of *Zea mays* NADP-MDH have yielded some confusing results. Decottignies et al. (8) concluded that activation of *Z. mays* NADP-MDH was due to reduction of a S-S group formed by vicinal cysteine residues near the N terminus of

native NADP-MDH. They were unable to detect any thiols with [¹⁴C]iodoacetate in the native unactivated enzyme and recorded two SH groups per subunit when the enzyme was reduced with ThR-m plus DTT. When the enzyme was denatured with urea before thiol analysis, two SH groups per subunit were detected in the unactivated enzyme, and four SH groups after reductive activation of the enzyme. However, different results were obtained in other studies when this enzyme was activated in different ways and thiols were measured with different reagents. Jacquot et al. (14) recorded three SH groups per subunit in the unactivated enzyme and six SH in the activated enzyme measured by either iodoacetate or DTNB after denaturation. Analyzing SH groups with DTNB, Jenkins et al. (15) found one SH per subunit in the native unactivated enzyme and five SH per subunit in the active native enzyme. Six SH groups per subunit were recorded after borohydride reduction. Kagawa and Bruno (17) analyzed SH groups with ¹⁴C-labeled NEM and found three SH groups per subunit in the native unactivated enzyme and nine SH in the native active enzyme generated by prolonged incubation with DTT. These different studies suggest that at least one and up to two or three S-S groups are reduced during the activation of NADP-MDH. Notably, the cDNA-derived amino acid sequence shows that native *Z. mays* NADP-MDH contains 8 cysteine residues (19).

The curves for activation of both pea (22, 23) and maize (13, 18, 20) NADP-MDH as a function of time are often sigmoidal in shape rather than hyperbolic. Scheibe (22) suggested that this sigmoidal type of activation kinetics could be accounted for if a particular S-S must be reduced in all four subunits of tetrameric NADP-MDH to give active enzyme. Alternatively, this behavior may be related to options for sequential reduction of different S-S groups within an enzyme subunit. The purpose of the present study was to investigate the significance of the sigmoidal nature of the NADP-MDH activation process, especially in relation to the extent of S-S group reduction of the enzyme. Evidence is provided that reduction of certain S-S groups does not lead to activation of enzyme, but modifies the kinetics observed during subsequent activation.

MATERIALS AND METHODS

Materials

Zea mays plants were grown in soil in a naturally illuminated glasshouse maintained between 20 and 30°C. Bio-

¹ Abbreviations: NADP-MDH, NADP-malate dehydrogenase; ThR-m, thioredoxin-m; ThR-f, thioredoxin-f; ME, 2-mercaptoethanol; NEM, N-ethylmaleimide; DTNB, 5,5'-dithiobis(2-nitrobenzoic acid).

chemicals and reagent enzymes were obtained from Sigma Chemical Co. or Boehringer-Mannheim (Australia).

Purification and Assay of NADP-MDH and ThR-m

NADP-MDH was purified from *Z. mays* leaves in its unactivated form essentially as described by Ashton et al. (2). Activity was assayed after activation with DTT as described by Ashton et al. (2), except that 150 mM KCl was included in the assay mixture to eliminate any effect of adding enzyme samples containing high [KCl].

ThR-m was purified to homogeneity from *Z. mays* leaves by a procedure (A. Agostino and M.D. Hatch, unpublished data) involving heating crude leaf extracts to 100°C and then fractionating the remaining soluble protein by $(\text{NH}_4)_2\text{SO}_4$ precipitation and then Sephacryl S-200 and DEAE-Sepharose 6B chromatography. ThR-m was assayed by measuring its capacity to activate purified unactivated NADP-MDH in reaction mixtures described below.

Kinetics of Activation of NADP-MDH

Activation of Purified NADP-MDH

Reactions containing purified unactivated NADP-MDH (approximately 2.5 μg of protein), 25 mM Hepes- K^+ , pH 7.5 or 7.9, 200 mM KCl, 0.5 mM EDTA, 5 mM DTT, and purified ThR-m (about 0.1 μg or as specified) in a total volume of 0.5 ml were incubated at 25°C. Triton X-100 (0.003%, w/v) was generally included to reduce the tendency of NADP-MDH in these dilute solutions to adsorb to the reaction tube walls, especially glass tubes. At intervals, aliquots of the reaction were assayed for NADP-MDH activity (see above).

Pretreatment of NADP-MDH with ME was conducted in the reaction medium described above, except that ThR-m and DTT were omitted and ME was included at a concentration of 100 mM. After preincubating this mixture and controls (no ME) for 60 to 120 min at 25°C, the missing components were added and the kinetics of NADP-MDH activation followed.

Where NADP-MDH was exposed to oxidizing conditions after reduction with ME, the ME pretreatment procedure described above was scaled up by a factor of 5. After preincubation with ME, samples were treated on a 20-ml column of Sephadex G-25 previously equilibrated with the basic reaction mixture described above, and about 2 ml of the excluded protein peak were collected. This sample, free of ME, was then incubated in air (along with controls not treated with ME or with ME not removed). In some experiments, ThR-m was included to accelerate the reoxidation of protein SH groups. After this treatment, the kinetics of NADP-MDH activation were determined by adding the components missing from the complete reactivation mixtures.

The total NADP-MDH activity, and hence the recovery of NADP-MDH following these procedures, was determined by incubating samples at 25°C with 100 mM DTT in 50 mM Tricine, pH 8.8, 200 mM KCl, 0.5 mM EDTA, and 0.003% (w/v) Triton X-100 until the enzyme was completely activated (generally about 1 h).

Activation in Isolated Chloroplasts

Mesophyll chloroplasts were prepared from *Z. mays* leaves as described by Jenkins and Russ (16). After suspension in a medium containing 0.3 M sorbitol, 25 mM Hepes- K^+ , pH 7.8, and 0.5 mM EDTA, the chloroplasts were incubated for 5 min at 20°C in the dark to completely inactivate NADP-MDH, and then were illuminated at 800 $\mu\text{E m}^{-2} \text{s}^{-1}$. The final chloroplast concentration was equivalent to about 100 $\mu\text{g Chl ml}^{-1}$. At intervals, 0.1 ml aliquots were added to 10 μl of a mixture containing 1% Triton X-100 and 0.1 M DTT and immediately frozen in liquid nitrogen. Later, these mixtures were thawed, centrifuged at 10,000g for 20 s, and then assayed for NADP-MDH activity.

Activation in Illuminated Leaves

Expanded, detached *Z. mays* leaves (about 120 mm long) were darkened in a stream of humidified air (bases in water) for 90 min at 20°C and then illuminated in white light (approximately 800 $\mu\text{E m}^{-2} \text{s}^{-1}$). At intervals, individual leaves were removed and frozen by immersing in liquid nitrogen in tubes. Later the frozen leaf tissue was ground in a chilled mortar with about 3 volumes (w/v) of 50 mM Hepes- K^+ , pH 7.5, containing 10 mM DTT and 1 mM EDTA. After filtration through Miracloth, a sample was taken to measure Chl, and the remainder was centrifuged for 1 min at 10,000g. An aliquot of the supernatant fluid was immediately assayed for NADP-MDH activity.

Measurement of Protein Thiols

Thiols were measured colorimetrically after reacting protein samples with DTNB essentially as described by Habeeb (11). For all analyses, protein was first denatured by adding SDS to give a final concentration of 2%. Where protein was pretreated with ME or DTT, these reagents were removed by treatment on a Sephadex G-25 column before analysis. Samples for analysis contained between 80 and 160 μg of protein in a final volume of 1 ml. To reduce all S-S groups in NADP-MDH, samples were denatured with urea and then reduced with borohydride as described by Cavallini et al. (6). After this borohydride reduction, the blank for DTNB analysis of thiols was a control subjected to the whole procedure without protein.

Measurement of Chl and Protein

Chl was measured in 80% (v/v) acetone as described by Porra et al. (21). Protein was determined by measuring absorbance of solutions at 280 and 260 nm (24) or by the Coomassie blue procedure using BSA as a standard (4). The protein content of solutions of purified NADP-MDH was also assessed by measuring the absorbance at 280 nm and using a molar absorptivity index ($49,270 \text{ M}^{-1} \text{ cm}^{-1}$) calculated from the known amino acid composition of this protein (see refs. 1 and 19) as described by Gill and von Hippel (10). The protein content of ThR-m preparations was measured by the Coomassie blue procedure (4).

Calculation of In Vivo Concentration of NADP-MDH and ThR-m

Taking an average value of $25 \mu\text{mol min}^{-1} (\text{mg Chl})^{-1}$ as the specific activity of fully activated NADP-MDH extractable from maize mesophyll cells (fully expanded leaves of young plants grown in sunlight), the weight of NADP-MDH in leaves per unit Chl was calculated from the maximum specific activity of the purified enzyme of $550 \mu\text{mol min}^{-1} (\text{mg protein})^{-1}$ (2), assuming a subunit mol wt of 42,500 (1). The concentration of NADP-MDH in the stroma could be then calculated using a value for stroma volume of $20 \mu\text{L} (\text{mg Chl})^{-1}$.

Units of ThR-m activity, expressed as units of NADP-MDH activated under standard conditions (as described above but with 500 mM KCl), were determined in crude leaf extracts consisting largely of mesophyll cell contents (after heating 10 min at 95°C) and also in a ThR-m preparation purified to homogeneity (see above). The weight of ThR-m in leaves was then estimated from the specific activity of the purified protein. Apparent ThR-m was only marginally reduced by heating the crude extract.

RESULTS AND DISCUSSION

Kinetics of NADP-MDH Activation

Purified inactive NADP-MDH is rapidly activated when incubated with ThR-m plus 10 mM DTT at pH 7.5 (Fig. 1A). Under the conditions used in these studies, there is a distinct lag in the curve for activation of NADP-MDH, the extent of which is decreased as the concentration of ThR-m is increased. If activation is followed to completion, the shape of the complete curve is typically sigmoidal. Such sigmoidal-type activation kinetics for NADP-MDH have been noted in previous studies (18, 20, 22). In the present studies, increasing the DTT concentration up to 10 mM and KCl up to 500 mM also increased the rate of activation and decreased the length of the lag (Fig. 1C). However, even with the highest concentrations of ThR-m, DTT, and KCl used, a significant lag (sigmoidal response) remained. The strong influence of KCl

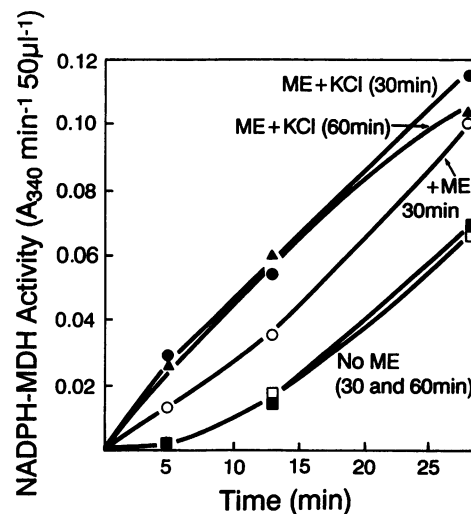

Figure 2. Effect of pretreating unactivated NADP-MDH with ME on the kinetics of activation of the enzyme. After the pretreatments shown on the individual graphs (100 mM ME, 200 mM KCl, 25°C , for the times shown), the activation reactions were commenced by adding ThR-m ($0.1 \mu\text{g}$) and DTT (final 10 mM) in a total volume of 0.5 mL. The pH was 7.9.

on the rate of ThR-m-mediated activation of NADP-MDH was observed in an earlier study (7). It is of interest to note that one preparation of purified NADP-MDH failed to show pronounced sigmoidal behavior during activation under these conditions. Except for a small apparent difference in thiol content (see below), the reason for this variation in behavior is not apparent. Non-lag phase kinetics of activation of *Z. mays* NADP-MDH was also observed in an earlier study (3). However, the very rapid rates of activation in those experiments ($t_{1/2}$ of about 10 min) suggest that much higher concentrations of ThR-m were present in the activation reactions. It should be noted that the purified enzyme used in the present study contained an N-terminal peptide apparently removed

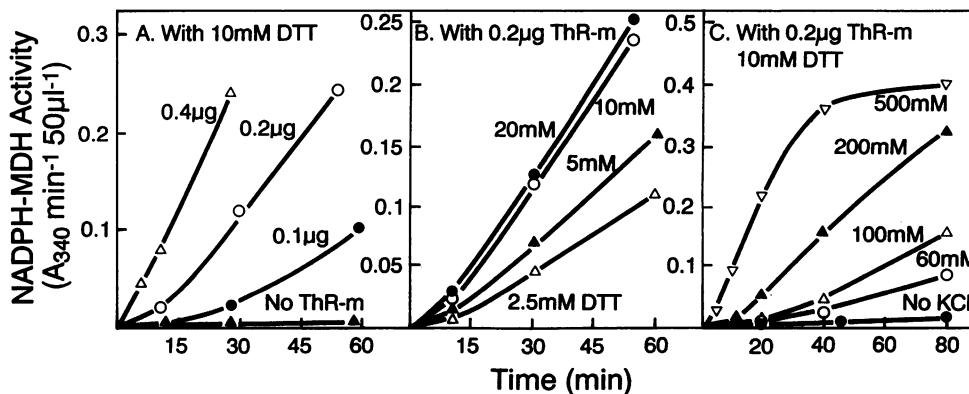

Figure 1. The effect of varying ThR-m (A), DTT (B), and KCl (C) on the kinetics of activation of NADP-MDH. The pH was 7.5 and, except where otherwise specified, the reactions contained $2.5 \mu\text{g}$ of unactivated NADP-MDH, $0.2 \mu\text{g}$ of ThR-m, 10 mM DTT, and 200 mM KCl in a total volume of 0.5 mL. For other details, see "Materials and Methods."

during the isolation of the enzyme used in some earlier studies (1).

Figure 2 shows that if unactivated NADP-MDH is preincubated with 100 mM ME prior to activation in the presence of ThR-m plus DTT, then the lag in the activation process is largely eliminated. Pretreatment with ME under these conditions did not activate NADP-MDH. Preincubation with 100 mM ME for 30 min was generally sufficient if 200 mM KCl was included, but only partly effective with lower K⁺ (about 30 mM included with Hepes buffer). Somewhat longer incubation was required if Triton X-100 was included in these treatments (see "Materials and Methods"). Pretreatment for about 30 min with 20 mM DTT under the same conditions was similarly effective in overcoming the lag in activation (data not shown).

When ME was removed from ME-pretreated NADP-MDH and the enzyme incubated then under oxidizing conditions, lag-phase type activation kinetics reappeared (Fig. 3). In this experiment, NADP-MDH was preincubated with ME for 100 min and then for either 30 or 170 min in air after ME was removed. ThR-m was added during this latter treatment to accelerate the oxidation process, since ThR-m catalyzes the oxidative inactivation of NADP-MDH as well as the reductive activation (3, 18). Reversion to lag-type activation kinetics, comparable to that seen in the control, required more than 30 min of incubation in air. A much slower reversion to lag-phase activation kinetics was observed when the ME-pretreated enzyme was incubated in air without ThR-m, and there was some irreversible inactivation of NADP-MDH during longer periods of incubation in air.

Regarding the physiological significance of these observations on the kinetics of activation NADP-MDH, two additional pieces of information are relevant. First, it may be important that the ratio of NADP-MDH to ThR-m used in our activation studies was very similar to the ratio apparently prevailing in vivo. The activation mixtures contained a ratio of NADP-MDH to ThR-m of about 25 on a weight basis or

about 7 on a protein subunit concentration basis. We have calculated the approximate in vivo concentration of NADP-MDH based on the maximum extractable activity of the enzyme in leaves and the known specific activity of the purified enzyme; likewise, the in vivo concentration of the ThR-m could be calculated from the specific capacity of boiled crude leaf extracts and purified ThR-m to activate added inactive NADP-MDH (see "Materials and Methods" for details). It should be noted that the estimation of ThR-m concentration was based on the heat-stable activity in crude leaf extracts (about 95°C, 10 min) and an assay system containing 500 mM KCl (see "Materials and Methods"), which activates ThR-m but not ThR-f (7). These calculations gave mesophyll chloroplast stromal concentrations of 52 μM for NADP-MDH and 7 μM for ThR-m (equivalent to 45 and 1.7 μg/mg Chl, respectively), i.e. very similar ratios as used in our in vitro studies. Of course, the absolute concentration of these components in the in vitro system was much lower than those prevailing in vivo.

Second, we determined the general form of the curves for activation of NADP-MDH following illumination of *Z. mays* leaves and isolated mesophyll chloroplasts. The curve for activation of NADP-MDH following the illumination of darkened leaves showed a distinct lag before the onset of rapid activation and, hence, was generally sigmoidal in shape (Fig. 4). However, the curve was complex, and after activation to about 50% of potential activity in the first min, there appeared to be a slow second phase of activation. When intact mesophyll chloroplasts were illuminated, there was no significant lag in the curve for activation of NADP-MDH (Fig. 4, inset). We have no explanation for this observation other than the possibility that the NADP-MDH disulfide groups reduced by ME in our in vitro system may be reduced already in these isolated chloroplasts. It should be noted that the curve for light-dependent activation of NADP-MDH in a broken pea leaf chloroplast system was highly sigmoidal (23). Of course, it is not certain that there is a common cause for

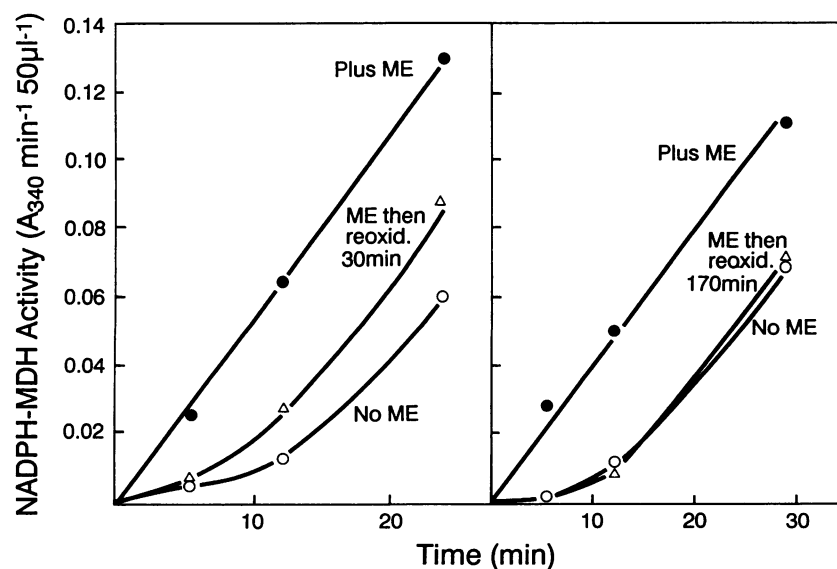

Figure 3. Effect of ME pretreatment of NADP-MDH and subsequent exposure to oxidizing conditions on the kinetics of activation of the enzyme. NADP-MDH was pretreated for 100 min with ME + KCl under the conditions described for Figure 2, and then ME was removed by desalting an aliquot on Sephadex G-25. The enzyme, free of ME, was then incubated in air in the presence of 0.1 μg of ThR-m for 30 (left) or 170 min (right) at 25°C (Δ). For details, see "Materials and Methods." Subsequent activation was commenced by adding DTT and also ThR-m (where not already present).

Table I. Changes in Thiol Content of NADP-MDH during Reduction and Activation of the Enzyme

Treatment and Activity Status ^a	Activity	Thiol (SH group) Content per NADP-MDH Subunit ^b		
		Standard A_{280}/A_{260} nm	Adjusted A_{280} nm	Coomassie blue
	% potential activity			
Oxidized (inactive)	0	1.7	2.2	2.4
ME-reduced (inactive)	2	3.6	4.4	4.6
DTT-reduced (active)	100 ^c	5.3	6.7	7.4
Borohydride-reduced (denatured)		8.8	9.2	

^a For details of procedures for the reduction of enzyme by ME, DTT, or borohydride, see "Materials and Methods." ^b Thiol content based on protein measured by the standard A_{280}/A_{260} formula (24), the molar absorptivity index at 280 nm calculated from the amino acid composition of NADP-MDH or by the Coomassie blue (4) procedure (see text and "Materials and Methods"). ^c The specific activity of the purified enzyme was between 500 and 600 $\mu\text{mol min}^{-1}$ (mg protein^{-1}) when fully activated either by incubating with 100 mM DTT, pH 8.8, or with ThR-m plus 10 mM DTT, pH 7.8.

the sigmoidal activation kinetics seen in these systems and the purified NADP-MDH system used in the present study.

Thiol Content of NADP-MDH

The results described above for the kinetics of activation of NADP-MDH might be explained by sequential reduction of different S-S groups in the unactivated enzyme. We therefore determined the thiol content of purified NADP-MDH after various reductive treatments (Table I). In all cases, the enzyme was denatured with SDS prior to thiol analysis using the reagent DTNB. Expressing the thiol content per NADP-MDH subunit requires accurate determination of the protein content of NADP-MDH preparations. It is this determination and not the analysis of thiols that is the greater source of potential error and variability. We therefore expressed results on the basis of protein determined by three different procedures (see "Materials and Methods"). Possibly the most accurate method is the one based on measuring the absorbance of protein at 280 nm and then calculating the concentration using a molar absorptivity index determined from the actual amino acid composition of NADP-MDH. Protein determined in this way gives values for SH content intermediate between the other two procedures.

The thiol content of unactivated (oxidized) NADP-MDH varied between 1.7 SH per subunit using values for protein determined by the standard 280/260 nm procedure, 2.2 SH per subunit using the A_{280} procedure mentioned above, and 2.4 SH per subunit using the Coomassie blue procedure for protein (Table I). Generally, the latter two procedures were in reasonable agreement. After pretreatment with ME under conditions that cause no increase in NADP-MDH activity but alter the kinetics of subsequent activation (see Fig. 2), the measured thiol level in the denatured enzyme was increased to about 4.4 SH per subunit. Reduction of the enzyme with DTT at pH 8.8 to give the activated form results in a further increase in the thiol content to 6.7 SH per subunit using the A_{280} protein assay. Following reduction of denatured NADP-MDH with borohydride to ensure the reduction of all S-S groups, the thiol content was estimated to be about nine SH per subunit.

Values of about two SH per subunit for denatured unactivated *Z. mays* NADP-MDH have been reported previously (8, 15), although Kagawa and Bruno (17) reported a value of about three SH per subunit. However, values reported for the increase in thiol content associated with the reductive activation of NADP-MDH have varied. Decottignies et al. (8) reported an increase of only two SH per subunit, whereas Jenkins et al. (15) recorded an increase of four SH per subunit, in reasonable agreement with our present results where the net increase after reduction with DTT was 4.5 SH (2.2–6.7 SH per subunit, Table I) based on protein determined by the A_{280} procedure. Kagawa and Bruno (17) reported an increase of 6 thiols after prolonged reduction with DTT (3.2–9.2 SH per subunit). This value of about 9 for the total thiol content is similar to the value we recorded after borohydride reduction of the enzyme and slightly higher than the theoretical

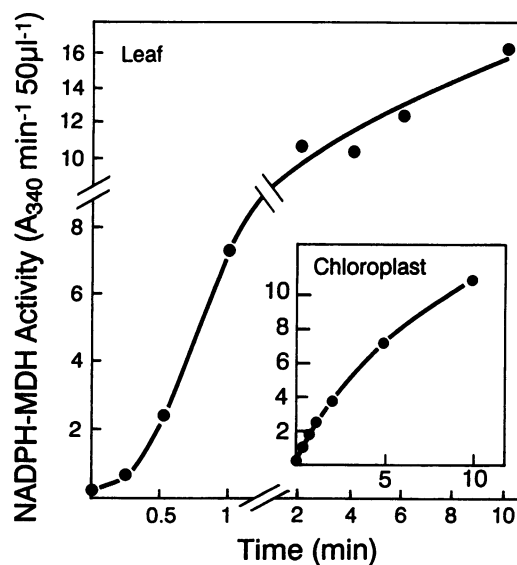

Figure 4. Kinetics of activation of NADP-MDH following illumination of *Z. mays* leaves or isolated mesophyll chloroplasts (inset) at $\sim 800 \mu\text{E m}^{-2} \text{ s}^{-1}$. For other details, see "Materials and Methods."

maximum value of eight SH based on amino acid sequence information (19).

Of particular interest for the present studies on the kinetics of activation of NADP-MDH is the fact that preincubation with ME does not activate the enzyme, but increases the thiol content by about two SH per subunit (Table I). Earlier, Kagawa and Bruno (17) had noted an increase in the thiol content of NADP-MDH without accompanying activation. However, after incubation with ME, they recorded an increase in total thiol content from three to seven SH per subunit. From our data, it would appear that ME reduces one S-S group per subunit. In a model to be developed below, we will suggest that unactivated NADP-MDH contains three S-S groups with different redox characteristics and different functions with regard to regulation of activity.

As already mentioned, one preparation of *Z. mays* NADP-MDH failed to show significant sigmoidicity in the shape of the curve for activation. It may be relevant that this preparation showed slightly lower thiol levels compared with the preparation described in Table I. The values for this enzyme, based on the A_{280} protein determination, were 1.5 SH per subunit for the oxidized enzyme and 4.2, 5.7, and 7.7 SH per subunit after treatment with ME, DTT, and borohydride, respectively.

CONCLUDING REMARKS

Our results do not allow a completely unambiguous reconciliation of the various differing reports (see above) on the thiol-disulfide status of active and unactivated NADP-MDH. However, using our data based on the A_{280} determination of protein, and assuming that the actual total cysteine content of NADP-MDH is eight per subunit (from the mature protein sequence, see ref. 19) and that the number of thiols per subunit will be whole numbers, we present below the simplest interpretation of our data. In developing this interpretation, it should be noted that the data based on A_{280} analysis of protein (Table I) comes out to almost exactly two, four, six, and eight SH per subunit for the oxidized, ME-reduced, DTT-reduced, and borohydride-reduced enzyme, respectively, if all values are decreased by about 10%. Accordingly, the unactivated enzyme may contain two SH groups per

subunit and presumably three S-S groups, as shown in the model in Figure 5. We suggest that one of these S-S groups is more readily reduced (higher redox potential), and this can be achieved in vitro with ME and does not give active enzyme. Treatment with stronger reducing systems (lower redox potential, DTT and ThR-m) results in reduction of this S-S plus an additional S-S group, giving an active enzyme with six SH groups per subunit and one S-S group. This latter S-S group is apparently reducible by treatment of the denatured enzyme with borohydride to give eight SH per subunit. Prolonged incubation of the enzyme with high concentrations of DTT may also reduce this S-S group, because Kagawa and Bruno (17) recorded up to nine SH per subunit after such treatment.

The scheme in Figure 5 provides a possible explanation for the lag-phase type kinetics observed for the activation of NADP-MDH. We suggest that the reduction of one particular S-S group, termed the regulatory S-S in Figure 5, is critical for the activation of the enzyme. However, a second, more readily reduced S-S (higher redox potential), termed here the preregulatory S-S, must first be reduced to give a form of NADP-MDH that can be activated by ThR-m, possibly as a result of a conformational change in the enzyme or a change in how the subunits of the dimeric enzyme interact with each other. The lag in activation of NADP-MDH is unlikely to be due to changes in the oligomeric state of the enzyme because both the active and unactivated forms of the enzyme are apparently dimers (1, 17). It is interesting in this connection that both unactivated NADP-MDH and especially active NADP-MDH have unusual molecular conformations, as judged by their behavior during gel filtration (1). For the experiments described in Figures 2 and 3, we propose that pretreatment with ME reduces this preregulatory S-S group, giving a form of inactive enzyme showing no lag in activation. Hence, the lag observed when the oxidized, inactive enzyme is activated would be a function of the time taken to reduce the preregulatory S-S group and generate the activatable form of the enzyme.

Our results are not consistent with the suggestion by Scheibe (22) to explain sigmoidal-type activation kinetics of NADP-MDH. Scheibe suggested that active enzyme may be generated only after reduction of a particular S-S group in

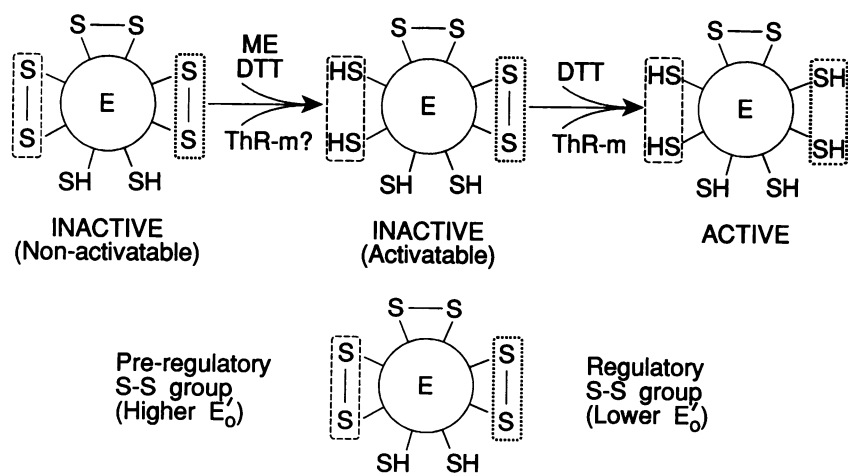

Figure 5. A model describing the possible changes in the dithiol-disulfide redox status of NADP-MDH during reductive activation of the enzyme. The significance of this scheme in relation to the observed sigmoidal activation kinetics of NADP-MDH is discussed in the text.

all four subunits of the tetrameric native inactive enzyme. This proposal does not explain the effect of ME pretreatment in eliminating the lag in activation kinetics. With the Scheibe mechanism, activation should always be sigmoidal in nature and presumably unaffected by conditions like the ThR-m or DTT concentration. Furthermore, with this mechanism, a pronounced lag is seen only when the enzyme is a tetramer. At least under our conditions, unactivated *Z. mays* NADP-MDH is a dimer (1).

It is difficult to assess what physiological significance this proposed bilevel disulfide group reduction mechanism might have. Regulation of NADP-MDH activity is important both to turn off the enzyme in the dark and to modulate its activity as incident light changes during the day (9). Notable in this connection is the fact that the core amino acid sequence of *Z. mays* NADP-MDH shows reasonable homology with NAD-MDH from various sources (19). However, NADP-MDH has, in addition, short unique polypeptides at both the N- and C-termini (19). What is particularly interesting is that both these peptides contain a pair of cysteine residues situated relatively close to each other and probably capable of forming S-S bonds. In fact, the pair close to the N terminus has been implicated in the regulation of NADP-MDH (8). There are, in addition, four other cysteine residues in the central core region of NADP-MDH that are not present in NAD-MDH sequences. In evolving a light regulation mechanism dependent on dithiol-disulfide interconversion, the simplest solution would have been to introduce a single, reversibly reducible S-S group. In fact, at least two and probably more reducible S-S groups were introduced into NADP-MDH. We suggest that these functionally different S-S groups provide the potential for a more sophisticated mechanism of light-dependent regulation of NADP-MDH in the leaves of *C₄* species and possibly also *C₃* species.

LITERATURE CITED

1. **Agostino A, Jeffrey P, Hatch MD** (1992) Amino acid sequence and molecular weight of native NADP malate dehydrogenase from the *C₄* plant *Zea mays*. *Plant Physiol* **98**: 1506–1510
2. **Ashton AR, Burnell JN, Furbank RT, Jenkins CLD, Hatch MD** (1990) Enzymes of *C₄* photosynthesis. In PJ Lea, ed, *Methods in Plant Biochemistry*, Vol 3. Academic Press, London, pp 39–72
3. **Ashton AR, Hatch MD** (1983) Regulation of *C₄* photosynthesis: physical and kinetic properties of active and inactive NADP malate dehydrogenase from *Zea mays*. *Arch Biochem Biophys* **227**: 406–415
4. **Bradford MM** (1976) A rapid and sensitive method for the quantitation of microgram quantities of protein utilising the principle of protein-dye binding. *Anal Biochem* **72**: 248–254
5. **Buchanan BB** (1991) Regulation of CO₂ assimilation in oxygenic photosynthesis: the ferredoxin/thioredoxin system. *Arch Biochem Biophys* **288**: 1–9
6. **Cavallini D, Graziani MT, Dupré S** (1966) Determination of disulphide groups in proteins. *Nature* **212**: 294–295
7. **Crawford NA, Yee BC, Hutcheson SW, Wolosiuk RA, Buchanan BB** (1986) Enzyme regulation in *C₄* photosynthesis: Purification, properties and activities of thioredoxins from *C₃* and *C₄* plants. *Arch Biochem Biophys* **244**: 1–15
8. **Decottignies P, Schmitter J-M, Miginiac-Maslow M, Le Maréchal P, Jacquot J-P, Gadal P** (1988) Primary structure of the light-dependent regulatory site of corn NADP malate dehydrogenase. *J Biol Chem* **263**: 11780–11785
9. **Edwards GE, Nakamoto H, Burnell JN, Hatch MD** (1985) Pyruvate, Pi dikinase and NADP malate dehydrogenase in *C₄* photosynthesis. *Annu Rev Plant Physiol* **36**: 255–286
10. **Gill SC, von Hippel PH** (1989) Calculation of protein extinction coefficients from amino acid sequence data. *Anal Biochem* **182**: 319–326
11. **Habeeb AFSA** (1972) Reaction of protein sulphhydryl groups with Ellman's reagent. *Methods Enzymol* **25**: 457–464
12. **Hatch MD** (1987) *C₄* photosynthesis: a unique blend of modified biochemistry, anatomy and ultrastructure. *Biochim Biophys Acta* **895**: 81–106
13. **Jacquot J-P, Buchanan BB, Martin F, Vidal J** (1981) Enzyme regulation in *C₄* photosynthesis. *Plant Physiol* **68**: 300–304
14. **Jacquot J-P, Gadal P, Nishizawa AN, Yee BC, Crawford NA, Buchanan BB** (1984) Enzyme regulation in *C₄* photosynthesis: mechanism of activation of NADP malate dehydrogenase by reduced thioredoxin. *Arch Biochem Biophys* **228**: 170–178
15. **Jenkins CLD, Anderson LE, Hatch MD** (1986) Malate dehydrogenase from *Zea mays* leaves: amino acid composition and thiol content of the active and inactive forms. *Plant Sci* **45**: 1–7
16. **Jenkins CLD, Russ VJ** (1981) Large scale rapid preparation of functional mesophyll chloroplasts from *Zea mays*. *Plant Sci Lett* **35**: 19–24
17. **Kagawa T, Bruno PL** (1988) NADP malate dehydrogenase from the leaves of *Zea mays*: purification and physical, chemical and kinetic properties. *Arch Biochem Biophys* **260**: 674–695
18. **Kagawa T, Hatch MD** (1977) Regulation of *C₄* photosynthesis: characterization of a protein factor mediating the activation and inactivation of NADP malate dehydrogenase. *Arch Biochem Biophys* **184**: 290–297
19. **Metzler MC, Rothermel BA, Nelson T** (1989) Maize NADP malate dehydrogenase: cDNA cloning, sequence, and mRNA characterization. *Plant Mol Biol* **12**: 713–722
20. **Miginiac-Maslow M, Decottignies P, Jacquot J-P, Gadal P** (1990) Regulation of corn leaf NADP malate dehydrogenase light activation by photosynthetic electron flow. *Biochim Biophys Acta* **1017**: 273–279
21. **Porra RJ, Thompson WA, Kriedeman PE** (1989) Determination of accurate extinction coefficients and simultaneous equations for assaying chlorophylls a and b extracted with four different solvents. *Biochim Biophys Acta* **975**: 384–394
22. **Scheibe R** (1984) Quantitation of the thiol groups involved in the reductive activation of NADP malate dehydrogenase. *Biochim Biophys Acta* **788**: 241–247
23. **Scheibe R, Jacquot J-P** (1983) NADP regulates the light activation of NADP-dependent malate dehydrogenase. *Planta* **157**: 548–553
24. **Warburg O, Christian W** (1941) Isolierung und krystallisation des garungsferment enolase. *Biochem Z* **310**: 384–421