

PROPRIETARY AND CONFIDENTIAL
 THE INFORMATION CONTAINED IN THIS DRAWING IS THE PROPERTY OF <INSERT COMPANY NAME HERE>. ANY REPRODUCTION OR TRANSMISSION OF THIS DRAWING WITHOUT THE WRITTEN PERMISSION OF <INSERT COMPANY NAME HERE> IS PROHIBITED.

SOLIDWORKS Educational Edition.
For Instructional Use Only.

		UNLESS OTHERWISE SPECIFIED:		NAME	DATE		
		DIMENSIONS ARE IN INCHES	DRAWN	A. GALLANT		TITLE:	
		TOLERANCES:	CHECKED				
		FRACTIONAL ±	ENG APPR.				
		ANGULAR: MACH ± BEND ±	MFG APPR.				
		TWO PLACE DECIMAL ±	Q.A.			SIZE	DWG. NO.
		THREE PLACE DECIMAL ±	COMMENTS:			A	SYRINGE HOLDER
		INTERPRET GEOMETRIC TOLERANCING PER:					REV
		MATERIAL					
		FINISH				SCALE: 1:1	WEIGHT:
		USED ON					SHEET 1 OF 5
		APPLICATION	DO NOT SCALE DRAWING				

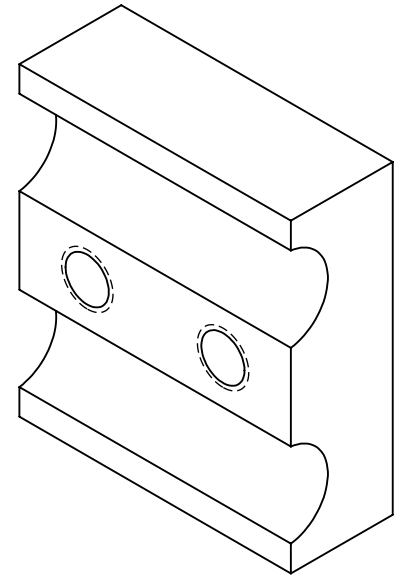
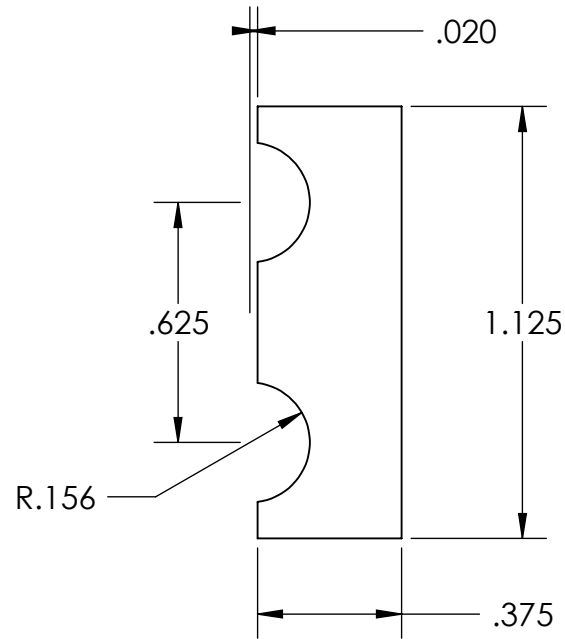
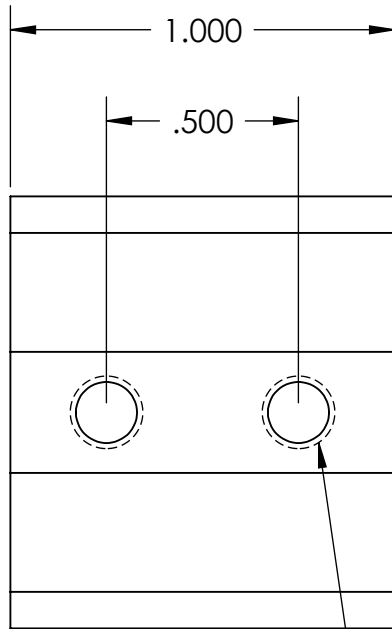

10-32 TAP THRU
TYP. 2 PLS.

PROPRIETARY AND CONFIDENTIAL
THE INFORMATION CONTAINED IN THIS DRAWING IS THE PROPERTY OF <INSERT COMPANY NAME HERE>. ANY REPRODUCTION OR TRANSMISSION OF THIS DRAWING WITHOUT THE WRITTEN PERMISSION OF <INSERT COMPANY NAME HERE> IS PROHIBITED.

SOLIDWORKS Educational Edition.
For Instructional Use Only.

		UNLESS OTHERWISE SPECIFIED:	NAME	DATE		
		DIMENSIONS ARE IN INCHES	DRAWN	A. GALLANT		
		TOLERANCES:	CHECKED		TITLE:	
		FRACTIONAL ±	ENG APPR.			
		ANGULAR: MACH ± BEND ±	MFG APPR.			
		TWO PLACE DECIMAL ±	Q.A.			
		THREE PLACE DECIMAL ±	COMMENTS:			
		INTERPRET GEOMETRIC TOLERANCING PER:			SIZE	DWG. NO.
		MATERIAL			A	MAIN CLAMP 1
		BLACK DELRIN				REV
		FINISH			SCALE: 2:1	WEIGHT:
		USED ON				SHEET 2 OF 5
APPLICATION		DO NOT SCALE DRAWING				

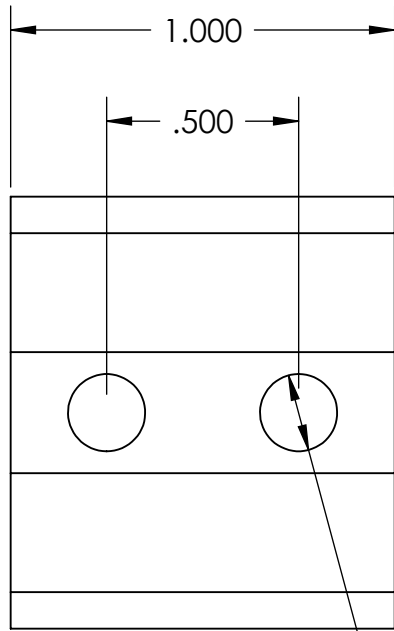

Ø .201 THRU
TYP. 2 PLS.

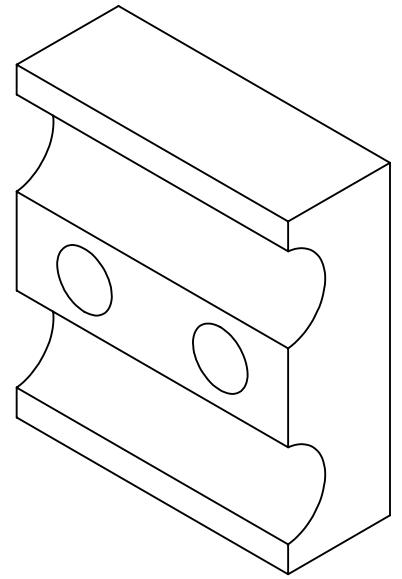
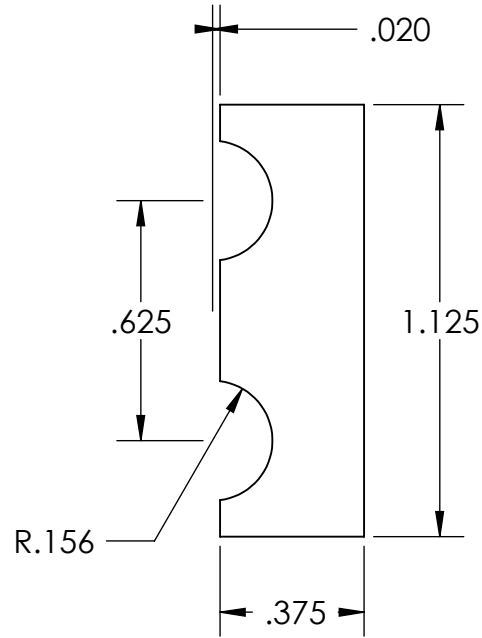

PROPRIETARY AND CONFIDENTIAL
 THE INFORMATION CONTAINED IN THIS DRAWING IS THE PROPERTY OF <INSERT COMPANY NAME HERE>. ANY REPRODUCTION OR TRANSMISSION OF THIS DRAWING WITHOUT THE WRITTEN PERMISSION OF <INSERT COMPANY NAME HERE> IS PROHIBITED.

SOLIDWORKS Educational Edition.
For Instructional Use Only.

		UNLESS OTHERWISE SPECIFIED:		NAME	DATE	
		DIMENSIONS ARE IN INCHES	DRAWN	A. GALLANT		TITLE:
		TOLERANCES:	CHECKED			
		FRACTIONAL ±	ENG APPR.			
		ANGULAR: MACH ± BEND ±	MFG APPR.			
		TWO PLACE DECIMAL ±	Q.A.			
		THREE PLACE DECIMAL ±	COMMENTS:			
		INTERPRET GEOMETRIC TOLERANCING PER:				SIZE
		MATERIAL				DWG. NO.
		BLACK DELRIN				MAIN CLAMP 2
		FINISH				REV
		USED ON				
	APPLICATION	DO NOT SCALE DRAWING				SCALE: 2:1
						WEIGHT:
						SHEET 3 OF 5

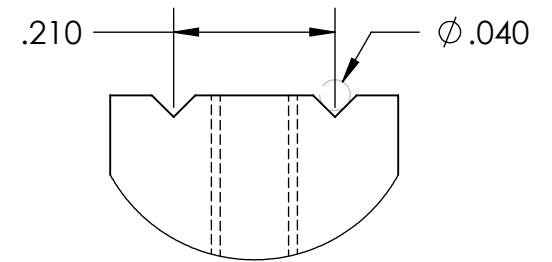
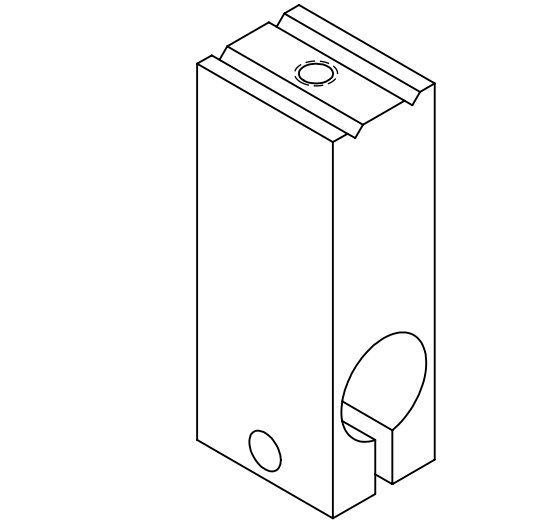
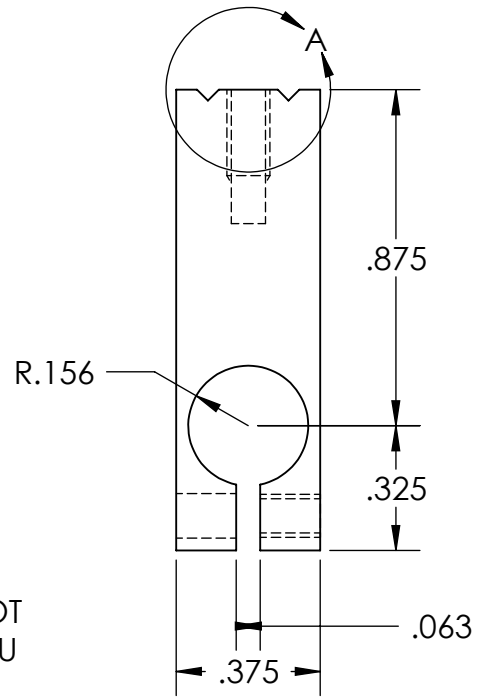
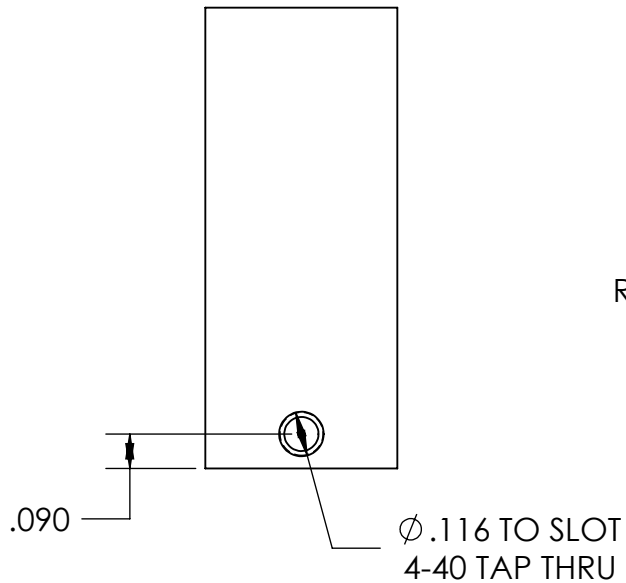
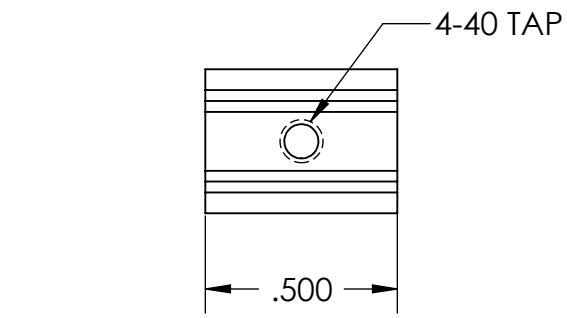

DETAIL A
SCALE 4 : 1

PROPRIETARY AND CONFIDENTIAL
 THE INFORMATION CONTAINED IN THIS DRAWING IS THE PROPERTY OF <INSERT COMPANY NAME HERE>. ANY REPRODUCTION OR TRANSMISSION OF THIS DRAWING WITHOUT THE WRITTEN PERMISSION OF <INSERT COMPANY NAME HERE> IS PROHIBITED.

SOLIDWORKS Educational Edition.
 For Instructional Use Only.

		UNLESS OTHERWISE SPECIFIED:		NAME	DATE	
		DIMENSIONS ARE IN INCHES TOLERANCES: FRACTIONAL \pm ANGULAR: MACH \pm BEND \pm TWO PLACE DECIMAL \pm THREE PLACE DECIMAL \pm	DRAWN	A. GALLANT		TITLE:
		INTERPRET GEOMETRIC TOLERANCING PER:	CHECKED			
		MATERIAL BLACK DELRIN	ENG APPR.			
		FINISH	MFG APPR.			
	USED ON		Q.A.			
	APPLICATION	DO NOT SCALE DRAWING	COMMENTS:			
			SIZE	DWG. NO.	REV	
			A	PIPETTE HOLDER		
			SCALE: 2:1	WEIGHT:	SHEET 4 OF 5	

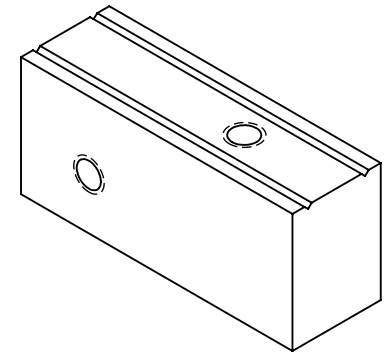

4-40 TAP THRU
TYP. 2 PLS.

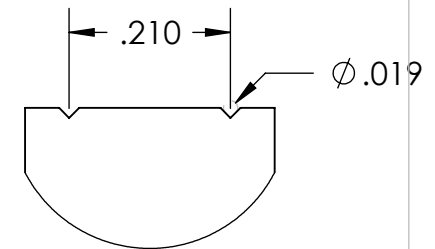
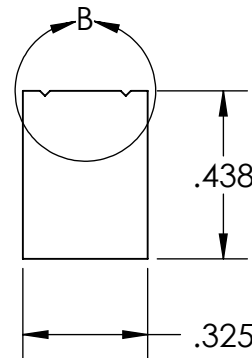
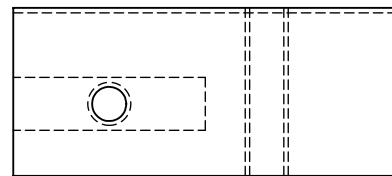
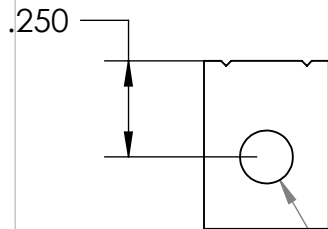
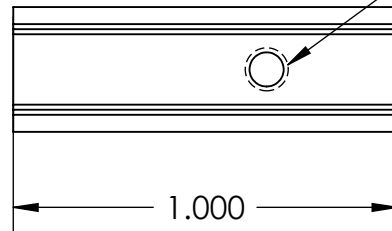

Ø.138 ∇ .500
S.F. FOR 3.5MM SHAFT

DETAIL B
SCALE 4 : 1

PROPRIETARY AND CONFIDENTIAL

SOLIDWORKS Educational Edition.
For Instructional Use Only.

THE INFORMATION CONTAINED IN THIS DRAWING IS THE PROPERTY OF <INSERT COMPANY NAME HERE>. ANY REPRODUCTION OR TRANSMISSION OF THIS DRAWING WITHOUT THE WRITTEN PERMISSION OF <INSERT COMPANY NAME HERE> IS PROHIBITED.

		UNLESS OTHERWISE SPECIFIED:		NAME	DATE	
		DIMENSIONS ARE IN INCHES TOLERANCES: FRACTIONAL \pm ANGULAR: MACH \pm BEND \pm TWO PLACE DECIMAL \pm THREE PLACE DECIMAL \pm	DRAWN	A. GALLANT		TITLE:
		INTERPRET GEOMETRIC TOLERANCING PER:	CHECKED			
		MATERIAL BLACK DELRIN	ENG APPR.			
		FINISH	MFG APPR.			
	USED ON		Q.A.			SIZE A DWG. NO. PLUNGER HOLDER REV SCALE: 2:1 WEIGHT: SHEET 5 OF 5
APPLICATION		DO NOT SCALE DRAWING	COMMENTS:			