

Electronic supplementary information (ESI) for Lab on a Chip

This journal is © The Royal Society of Chemistry 2024

# Observing root growth and signalling responses to stress gradients and pathogens using the bi-directional-dual flow-RootChip

Claudia Allan,<sup>a</sup> Yiling Sun,<sup>bc</sup> Steve Whisson,<sup>d</sup> Michael Porter,<sup>d</sup> Petra Boevink,<sup>d</sup> Volker Nock,<sup>\*bc</sup> and Claudia-Nicole Meisrimler<sup>\*a</sup>

<sup>a</sup>University of Canterbury, School of Biological Sciences, Private Bag 4800, Christchurch, New Zealand.

<sup>b</sup> University of Canterbury, Department of Electrical and Computer Engineering, Private Bag 4800, Christchurch, New Zealand.

<sup>c</sup> MacDiarmid Institute for Advanced Materials and Nanotechnology, PO Box 600, Wellington 6140, New Zealand.

<sup>d</sup> The James Hutton Institute, Cell and Molecular Sciences, Invergowrie, Dundee DD25DA, Scotland, United Kingdom.

\*Correspondence to Claudia Meisrimler <mailto:claudia.meisrimler@canterbury.ac.nz> or Volker Nock, [volker.nock@canterbury.ac.nz](mailto:volker.nock@canterbury.ac.nz)

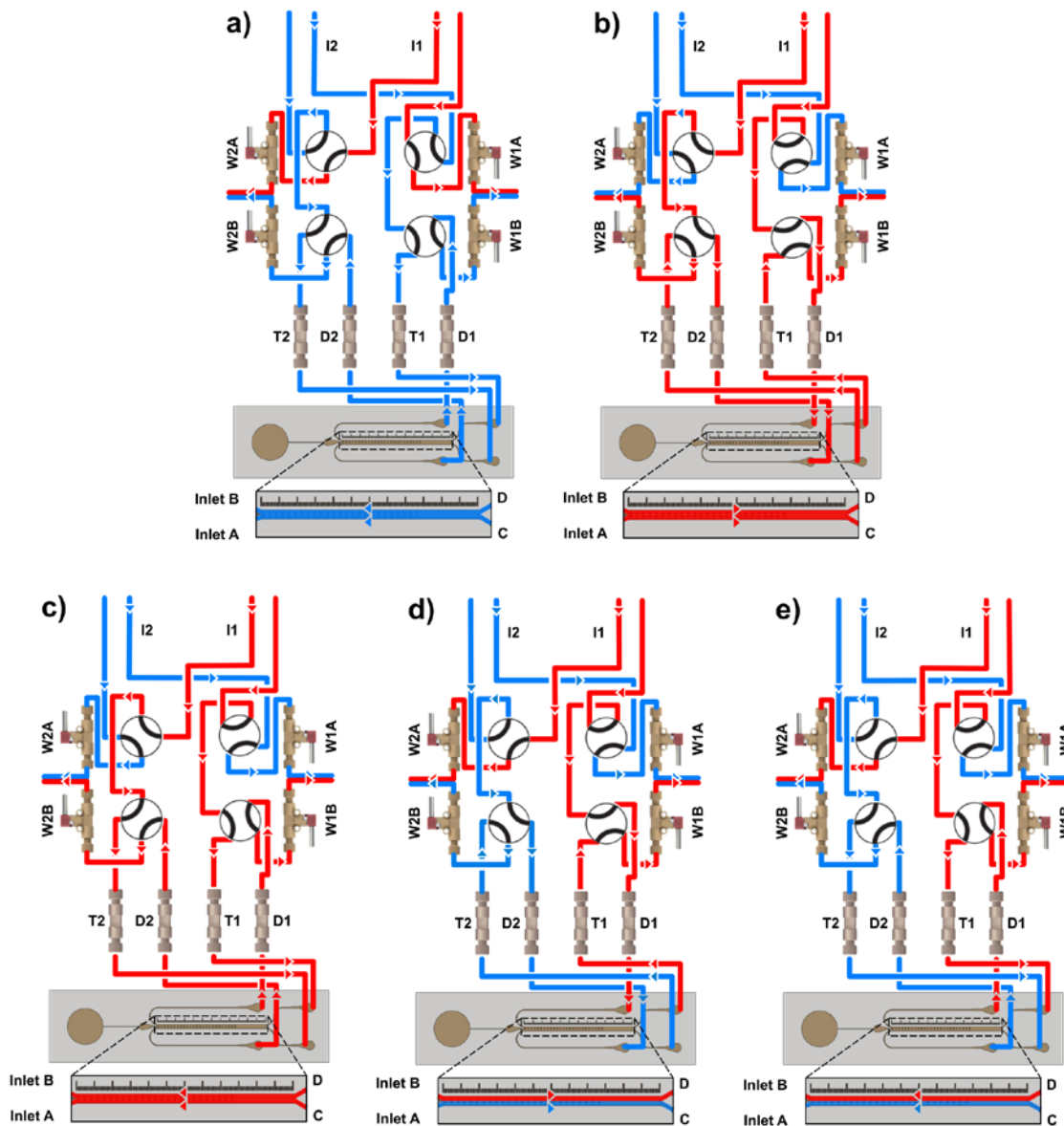
## List of contents:

Part I: Supplementary figures S1 – S7

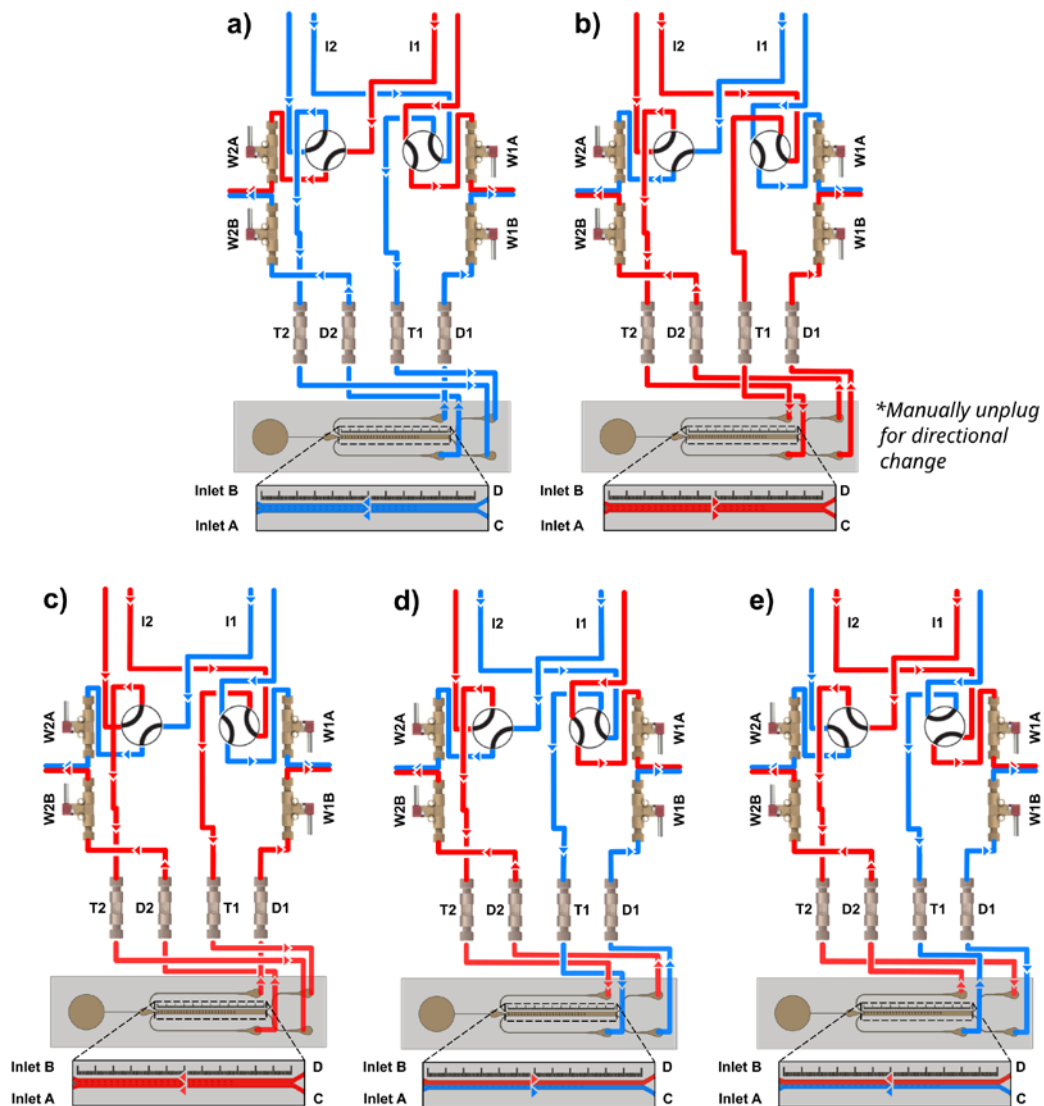
Part II: Supplementary movies V1 – V6

Part III: Supplementary mask files 1 – 5

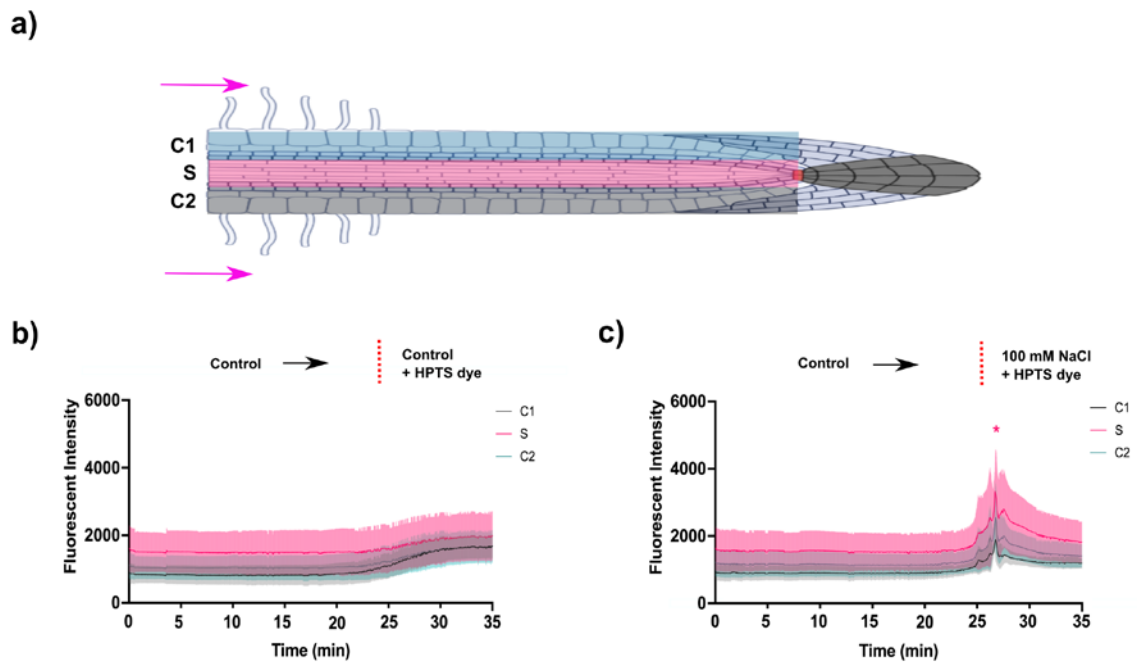
## Part I: Supplementary figures



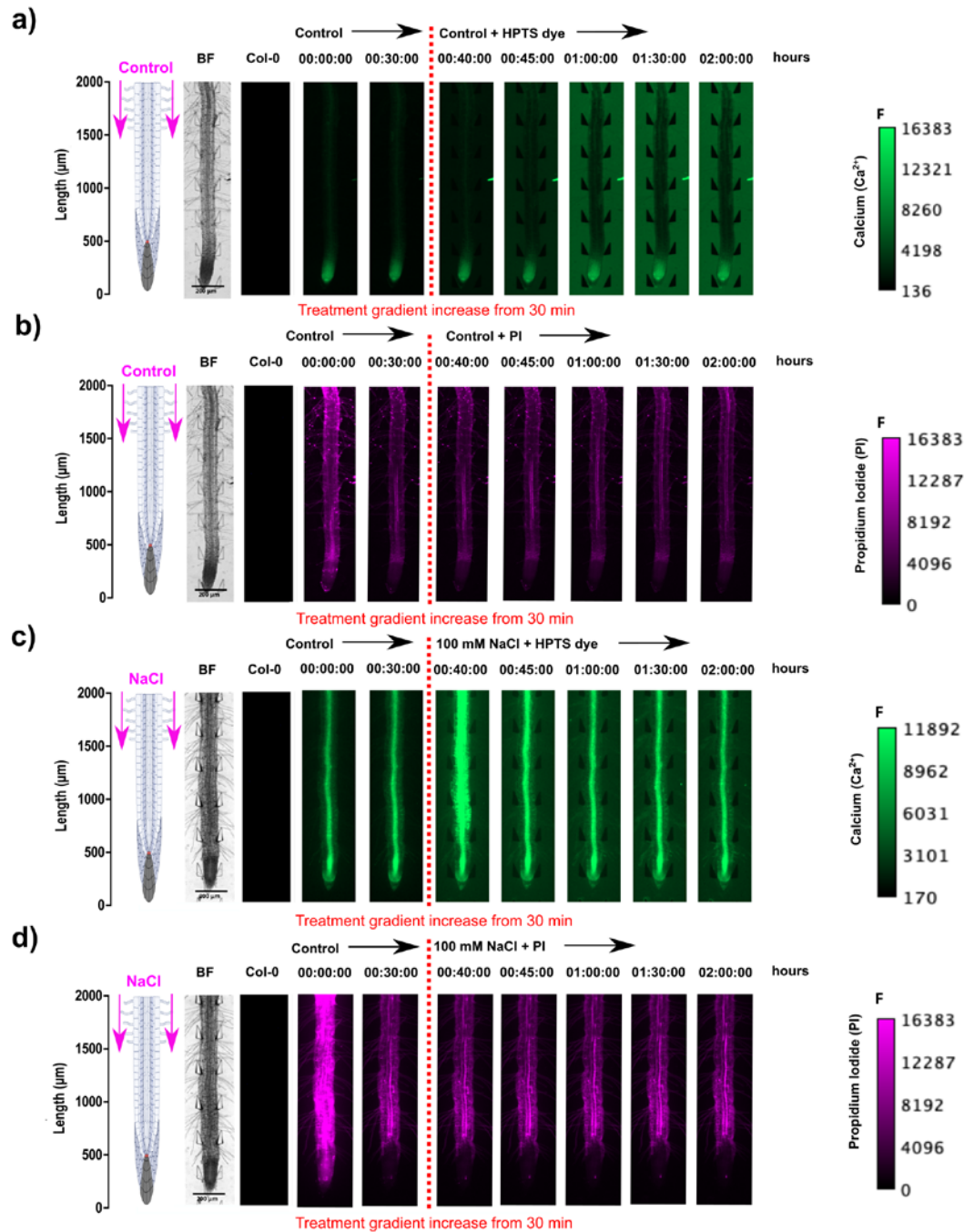
*Figure S1:* Schematic diagram depicting the variations in the MMDS version 1 flow matrix for solution and directional change via Manual Switching Valves between two separate test solutions into the bi-dfRC microchannel not covered by the main figures. All Low-Pressure Unions are labelled T1-T2 and D1-D2 and off-switches W1A-B and W2A-B. Treatment one depicted in blue and treatment two depicted in red. (a) Flow path for the application of full treatment one through inlets C & D (root site) of the bi-dfRC at the tip. (b) Flow path for the application of full treatment two through inlets A & B (shoot site) of the bi-dfRC at the differentiation zone. (c) Flow path for the application of full treatment two through inlets C & D of the bi-dfRC at the tip. (d) Flow path for the application of a one-sided treatment one through inlet A and treatment two through inlet B of the bi-dfRC at the shoot site. (e) Flow path for the application of a one-side treatment one through inlet C and treatment two through inlet D of the bi-dfRC at the tip.



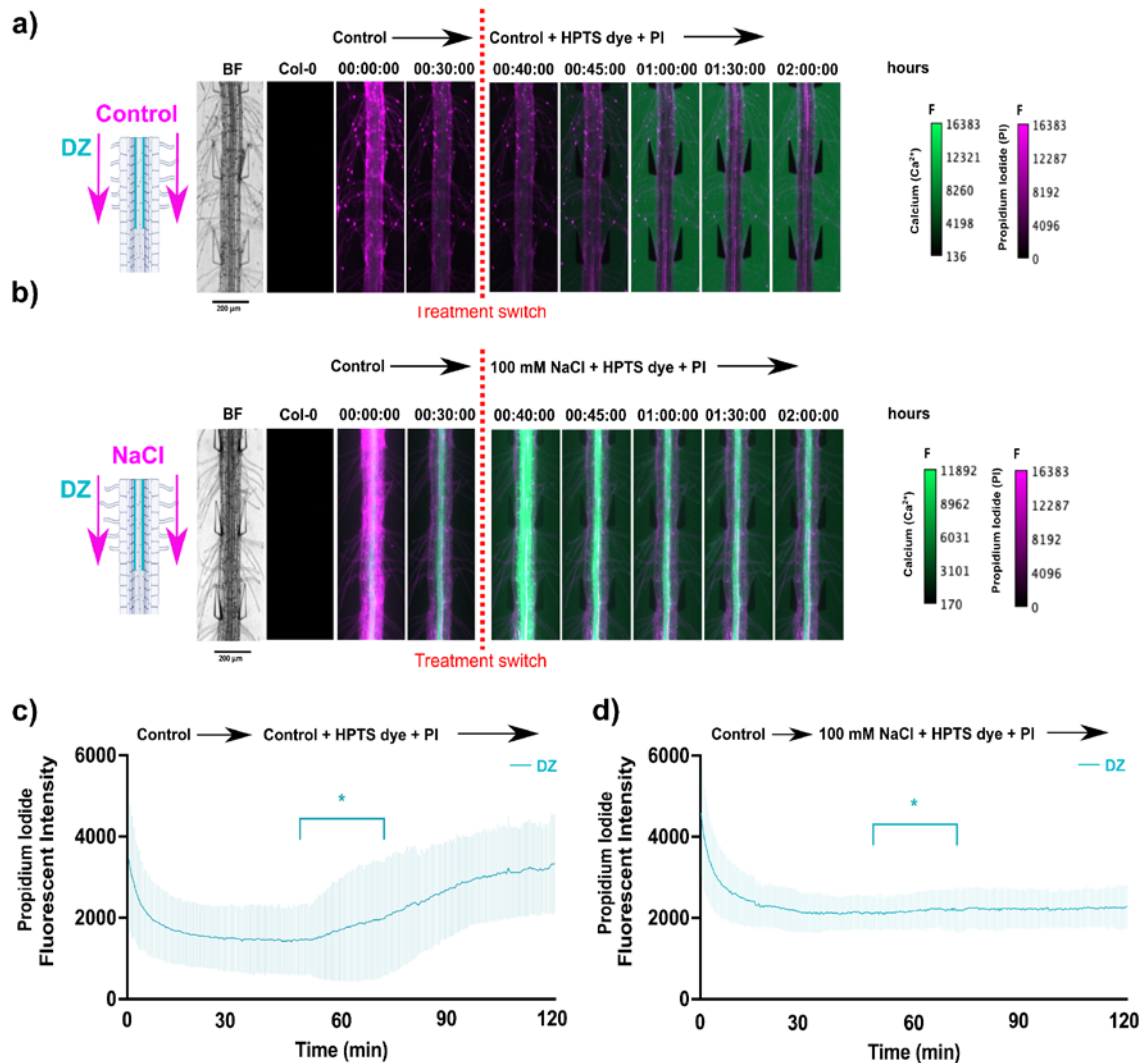
*Figure S2:* Schematic diagram depicting the remaining variations in the MMDS version 2 flow matrix for the solution change via Manual Switching Valves between of two separate test solutions into the bi-dfRC microchannel. Directional change is not applicable with this system, however inlets can be chosen prior to imaging, to direct treatment at the shoot or root site. All Low-Pressure Unions are labelled T1-T2 and D1-D2 and off-switches W1A-B and W2A-B. Treatment one depicted in blue and treatment two depicted in red. (a) Flow path for the application of full treatment one through inlets C & D (root site) of the bi-dfRC at the tip. (b) Flow path for the application of full treatment two through inlets A & B (shoot site) of the bi-dfRC at the differentiation zone. (c) Flow path for the application of full treatment two through inlets C & D of the bi-dfRC at the tip. (d) Flow path for the application of a one-side treatment one through inlet A and treatment two through inlet B of the bi-dfRC at the shoot site. (e) Flow path for the application of a one-side treatment one through inlet C and treatment two through inlet D of the bi-dfRC at the tip.



**Figure S3:** Spatiotemporal localisation of  $\text{Ca}^{2+}$  signals in *A. thaliana* G-CaMP3 roots upon salinity accumulation. Flow rate was set to  $20 \mu\text{L}/\text{min}$ . Control media ( $\frac{1}{2}$  MS/ $0.31 \text{ mM}$  MES) was injected into the bi-dfRC microchannel through inlets A & B (at the shoot site), steadily flowed for  $\sim 19$  minutes, then switched to the desired experimental treatment as a gradient. Original video files are 1 fps. (a) Schematic diagram of a root showing treatment application direction (magenta arrows) and rectangular regions of interest (highlighted). (b) Line graph with unpaired t-test (two-tailed) depicting average fluorescence intensity (grey scale; pixel brightness) of  $\text{Ca}^{2+}$  within 3 rectangular regions of interest (cortex 1 (C1), stele (S) and cortex 2 (C2)) upon targeted exposure of control treatment through inlet A & B, at the differentiation zone (DZ) ( $n=3$ ). (c) Line graph depicting average fluorescence intensity of  $\text{Ca}^{2+}$  across 3 rectangular regions upon NaCl treatment through inlet A & B, at the DZ ( $n=3$ ). Asterisks (\*) indicate statistical significance at the stele zone.

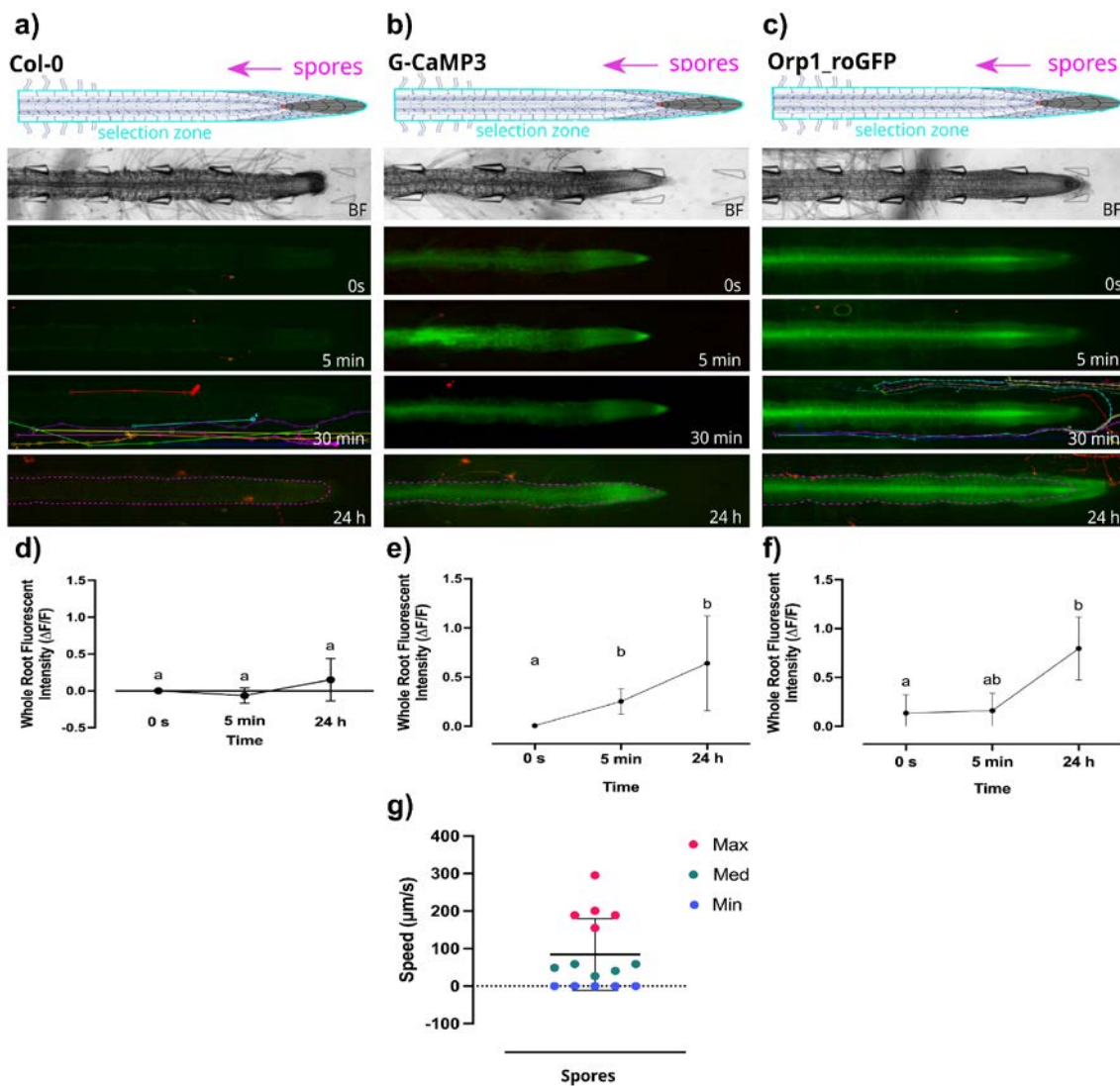


**Figure S4:** Propidium iodide (PI) staining of an *A. thaliana* G-CaMP3 root during signal analysis. Channels have been separated to show PI staining separately from  $\text{Ca}^{2+}$  signal analysis. Replicates are exposed to a steady flow (20  $\mu\text{L}/\text{min}$ ) and subsequent solution change through inlets A & B at the shoot site. The bright field (BF) channel and control (wild type Col-0) roots are displayed on the left. Original video files are 0.05 fps. (a) No  $\text{Ca}^{2+}$  burst indicated by the G-CaMP3 was observed upon solution change to control (half MS/0.31 mM MES) media plus HPTS dye, over 2 hours (n=3). The calibration bar displays GFP fluorescence (F= fluorescence intensity). (b) Shoot-ward transport of PI stain within the xylem following solution change to control media plus HPTS dye, over 2 hours (n=3). The calibration bar displays RFP fluorescence (shown as magenta for display). (c) A  $\text{Ca}^{2+}$  burst indicated by the G-CaMP3 was observed upon solution change to 100 mM NaCl plus HPTS dye, over 2 hours (n=4). (d) No PI stain transport was observed following solution change to 100 mM NaCl plus HPTS dye, over 2 hours (n=4).

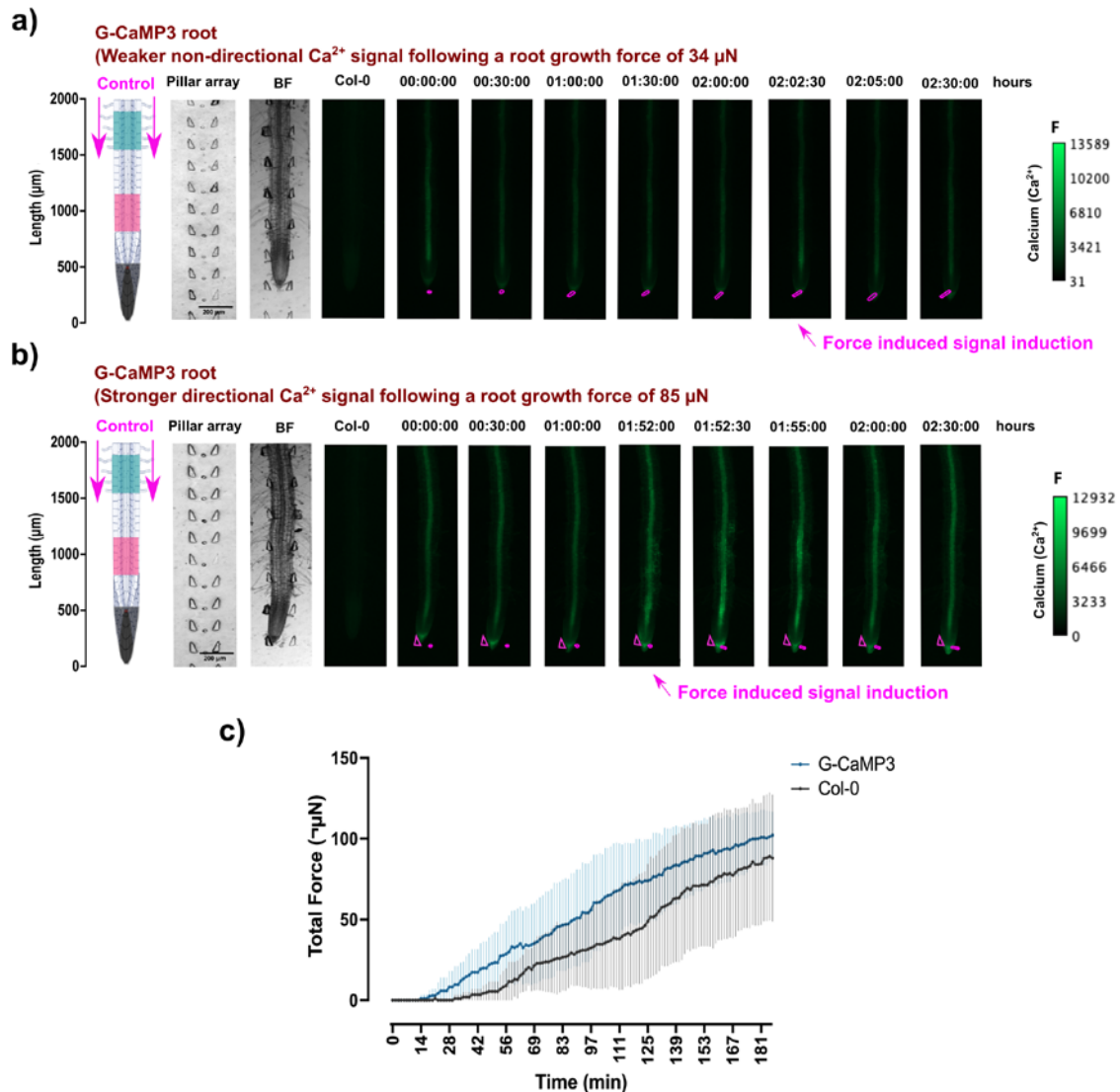


**Figure S5:** Propidium iodide (PI) staining of *A. thaliana* G-CaMP3 roots and the subsequent movement of the PI stain through the xylem were documented in the differentiation zone of the root under varying solute concentrations. The continuous flow ( $20 \mu\text{L}/\text{min}$ ) of control media ( $\frac{1}{2}$  MS/0.31 mM MES) is maintained for 30 minutes. Solution change caused a gradient shown for control and 100 mM NaCl for 2 hours. All experiments used a concentration of 0.01 mM HPTS dye (green) to show solution change. Root schematics on the left depict treatment application (magenta arrows) and the rectangular regions of interest (blue, refer to key). The bright field (BF) channel and control (wild type Col-0) roots are displayed adjacently (scale; F= fluorescence intensity). Original video files are 0.05 fps. All line graphs include a two-tailed paired t-test ( $P$ -value  $\leq 0.05$ ) with a 95% confidence interval. (a) Under control conditions, PI stain (RFP; magenta) is transported shootwards through the xylem over 2 hours, following the treatment switch to control media supplemented with HPTS dye ( $n=3$ ). (b) During salinity stress, PI stain is retained in, with reduced transported through the xylem and phloem over 2 hours, subsequent to treatment switch to 100 mM NaCl supplemented with HPTS dye ( $n=4$ ). (c) Line graph showing the average fluorescence intensity (grey scale; pixel brightness) of PI stain within the xylem of the DZ upon targeted exposure of control treatment for a duration of 2 hours ( $n=3$ ). (d) Line graph showing the average fluorescence intensity of PI stain within the xylem of the DZ upon treatment switch to 100 mM NaCl for a duration of 2 hours ( $n=4$ ). Asterisks (\*) indicate statistical significance.





**Figure S6:** *P. capsici* cell suspension with motile zoospores induces different patterns of  $\text{Ca}^{2+}$  and  $\text{H}_2\text{O}_2$  signals in *A. thaliana* wild type Col-0 and transgenic G-CaMP3 and Orp1\_roGFP, over 24 h. Schematic diagrams located above heat maps (GFP) depict the plant line, treatment directionality and the selection area for whole root signal analysis (cyan outline). Below, bright field (BF) images depict primary root situation in the bi-dfRC observation channel. Zoospores have been tracked using various coloured lines, shown at the 30 min time point, for display. The root outline was taken from time point 0, then overlaid using a magenta dotted line at the 24 h time point, to show the difference in swelling and tip growth. Original video files are 0.2 fps. All line graphs depict normalised ( $\Delta F/F$   $\Delta F/F$ ) fluorescence intensity of the whole root. (a) No signalling was observed in the Col-0 primary roots exposed to pathogen treatment or zoospore localisation over 24 h. (b) A strong  $\text{Ca}^{2+}$  burst indicated by the G-CaMP3 was observed over 30 min and minimal root swelling is observed 24 h following pathogen infection. (d) A gradual increase in  $\text{H}_2\text{O}_2$  as Orp1\_roGFP fluorescence was observed over 30 min and root swelling is observed 24 h following pathogen infection. Line graphs with two-tailed paired t-test ( $P$ -value  $\leq 0.05$ ) with a 95% confidence interval depicting whole root average fluorescence intensity (grey scale; pixel brightness) of (d) Col-0 (no signal), (e) G-CaMP3 and (f) Orp1\_roGFP roots over 24 h responding to *P. capsici* cell suspension and zoospore germination. Whole root fluorescence is significantly higher for both  $\text{Ca}^{2+}$  and  $\text{H}_2\text{O}_2$  24 h following pathogen infection. (g) Box and whisker plot illustrating the maximum (upper whisker), minimum (lower whisker), and mean speed (central box) of different zoospores localising to *A. thaliana* roots over a 30-minute period ( $n=5$ ).



**Figure S7:** The spatiotemporal localisation of Ca<sup>2+</sup> signals in *A. thaliana* G-CaMP3 roots is observed at the tip before, during, and after touch stress for 2.5 hours. Displayed on the left are root schematics depicting treatment application (magenta arrows) with rectangular regions of interest highlighted (refer to key). The bright field (BF) with pillar array channel and control (wild type Col-0) roots are displayed adjacently (scale; F= fluorescence intensity). Heat maps include pillar overlay for display purposes (magenta lines). Original video files are 0.08 fps. (a) Fluorescence images (GFP) depicting Ca<sup>2+</sup> release indicated by the G-CaMP3 upon root tip contact with a displaceable micropillar. A non-directional localised Ca<sup>2+</sup> burst was observed at the tip and elongation zone at approximately 2 hours. (b) Fluorescence images (GFP) depicting Ca<sup>2+</sup> release, indicated by the G-CaMP3 upon root tip contact with both a displaceable micropillar and the guidance array. A strong directional Ca<sup>2+</sup> signal was observed at the tip, elongation and differentiation zone at 1 hour 52 minutes. (c) Root growth force upon displacement of a 100  $\mu$ m (H) versus 30  $\mu$ m (W) PDMS micropillar. G-CaMP3-labeled roots shown in blue and Col-0 wild type (WT) roots shown in black. Root growth is observed over approximately 180 minutes under control conditions ( $\frac{1}{2}$  MS/0.31 mM MES solution) within a bi-dfRC microchannel with force sensing pillars.



## Part II: Supplementary movies

**Movie V1:** “Clip 1: Change of solution color in the presence of an *A. thaliana* Col-0 root, utilising the multiplex media delivery system variation 1. Control treatment ( $\frac{1}{2}$  MS/0.31 mM MES) was switched from colorless to coloured from the shoot site (differentiation zone). Color change occurred as a red and blue asymmetrical treatment simultaneously on both sides of the observation channel. This colour change was observed at 30 min. The flow rate was set to 20  $\mu$ l/min. The playback rate is 30 fps. Clip 2: Change of solution color in the presence of an *A. thaliana* Col-0 root, utilising the multiplex media delivery system variation 1. Control treatment ( $\frac{1}{2}$  MS/0.31 mM MES) was switched from colorless to coloured from the tip site (root tip). Color change occurred as a red and blue asymmetrical treatment simultaneously on both sides of the OC. This colour change was observed at 30 min. The flow rate was set to 20  $\mu$ l/min. The playback rate is 30 fps. Clip 3: Change of solution color in the presence of an *A. thaliana* Col-0 root, utilising the multiplex media delivery system variation 2. Control treatment ( $\frac{1}{2}$  MS/0.31 mM MES) was switched from colorless to coloured from the shoot site (differentiation zone). Color change occurred as a red and blue asymmetrical treatment simultaneously on both sides of the OC. This colour change was observed at 10 min. Flow rate set to 20  $\mu$ L/min. The playback rate is 1.00 fps. Clip 4: Change of solution color in the presence of an *A. thaliana* Col-0 root, utilising the multiplex media delivery system variation 2. Control treatment ( $\frac{1}{2}$  MS/0.31 mM MES) was switched from colorless to coloured from the tip site (root tip). Color change occurred as a red and blue asymmetrical treatment occurred simultaneously on both sides of the OC. This colour change was observed at 10 min. Flow rate set to 20  $\mu$ L/min. The playback rate is 1.00 fps.”

**Movie V2:** “Clip 1: An *A. thaliana* Col-0 root exposed to control  $\frac{1}{2}$  MS/0.31 mM MES media through inlet A & B of the bi-dfRC at the shoot site (differentiation zone). No  $\text{Ca}^{2+}$  burst is observed over 10 minutes. The playback rate is 30 fps. Scale bar, 200  $\mu$ m. Clip 2: An *A. thaliana* G-CaMP3 root exposed to control  $\frac{1}{2}$  MS/0.31 mM MES media through inlet A & B of the bi-dfRC at the shoot site (differentiation zone). No  $\text{Ca}^{2+}$  burst is observed over 10 minutes. The playback rate is 30 fps. Scale bar, 200  $\mu$ m. Clip 3: HPTS dye solution change tracking of a gradient concentration build-up within the bi-dfRC microchannel, in the presence of an *A. thaliana* G-CaMP3 root at the shoot site (differentiation zone). Visualisation of solution change from  $\frac{1}{2}$  MS/0.31 MES (control) media to control media plus 0.01 mM HPTS fluorescent indicator is observed at approximately 18 minutes, 30 seconds. No  $\text{Ca}^{2+}$  burst is observed in response to the dye. The playback rate is 100 fps. Scale bar, 200  $\mu$ m. Clip 4: HPTS dye solution change tracking of a gradient concentration build-up, in addition to an NaCl induced- $\text{Ca}^{2+}$  burst within the bi-dfRC microchannel, in an *A. thaliana* G-CaMP3 root at the shoot site (differentiation zone). Visualisation of solution change from  $\frac{1}{2}$  MS/0.31 MES (control) media to 100 mM NaCl plus 0.01 mM HPTS fluorescent indicator is observed at approximately 18 minutes, 30 seconds. A strong concentration dependent  $\text{Ca}^{2+}$  burst initiating at 23 minute, 30 seconds. The playback rate is 100 fps. Scale bar, 200  $\mu$ m.”

**Movie V3:** “Clip 1: Propidium iodide (PI) staining of an *A. thaliana* G-CaMP3 root under a steady flow rate (20  $\mu$ L/min) of  $\frac{1}{2}$  MS/0.31 mM MES (control) treatment at the shoot site (differentiation zone). Bright field, GFP and RFP channels are stacked and the RFP channel was adjusted to magenta, for visualisation purposes. Treatment application through inlets A & B of the bi-dfRC induced the movement of the PI stain shoot-ward through the xylem of the root, over 2 hours. Fluorescent HPTS dye was introduced to monitor solution change. Prior to imaging, roots were treated with 100  $\mu$ M PI stain for 10 minutes, then run under a steady flow of control media for 30 minutes. Fluorescent filters were manually brightened to 7500 in Zen Blue, for visualisation purposes. The playback rate is 15 fps. Scale bar, 200  $\mu$ m. Clip 2: Propidium iodide (PI) staining of an *A. thaliana* G-CaMP3 root under a steady flow rate (20  $\mu$ L/min) of 100 mM NaCl stress at the shoot site (differentiation zone). Bright field, GFP and RFP channels are stacked and the RFP channel was adjusted to magenta,

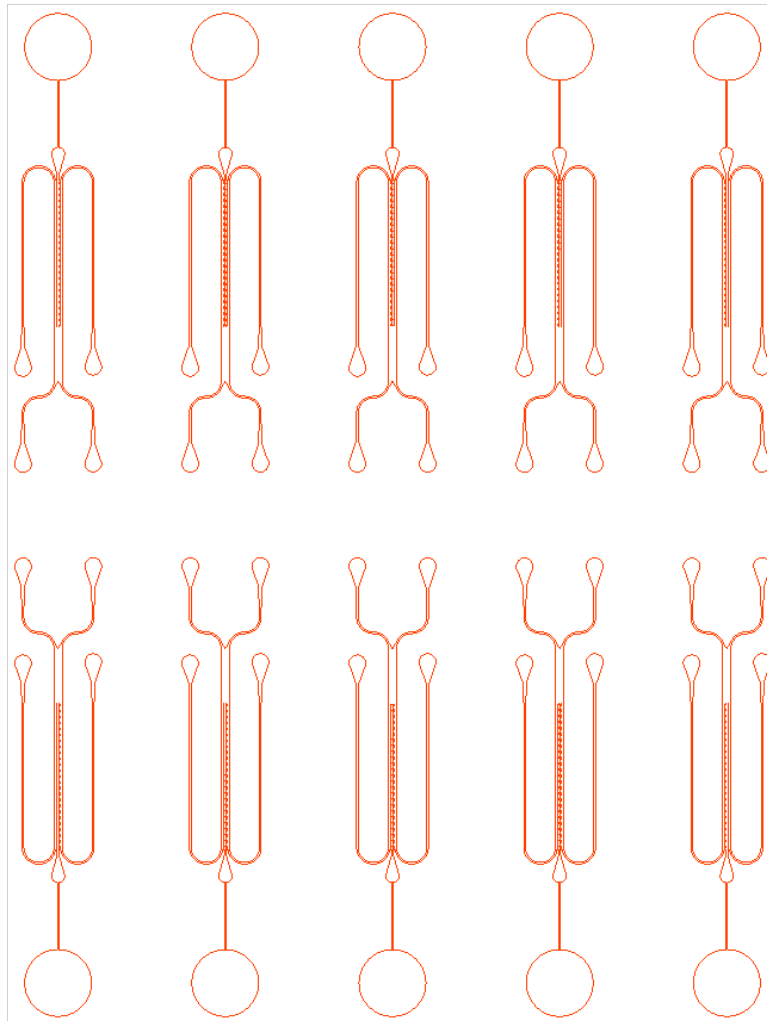
for visualization purposes. Solution change from ½ MS/0.31 mM MES (control) to 100 mM NaCl treatment through inlets A & B of the bi-dfRC induced a Ca<sup>2+</sup> response over 1.5 hours, but no PI stain movement. Fluorescent HTPS dye was added to observe solution change. Prior to imaging, roots were treated with 100 µM PI stain for 10 minutes, then run under a steady flow of control media for 30 minutes. GFP and RFP filters were manually brightened to 7500 in Zen Blue, for visualization purposes. The playback rate is 15 fps. Scale bar, 200 µm.”

**Movie V4:** “Clip 1: Force sensing of an *A. thaliana* Col-0 root growing in the bi-dfRC observation channel over 2.5 hours, under steady flow (20 µL/min) of ½ MS/0.31 mM MES media at the shoot site (inlets A and B) of the bi-dfRC, adjoining at the root differentiation zone. No Ca<sup>2+</sup> signal is observed upon singular pillar displacement. The playback rate is 75 fps. Scale = 200 µm. Clip 2: Force sensing of an *A. thaliana* G-CaMP3 root growing in the bi-dfRC observation channel over 2.5 hours, under steady flow (20 µL/min) of ½ MS/0.31 mM MES media at the shoot site (inlets A and B) of the bi-dfRC, adjoining at the root differentiation zone. A localized Ca<sup>2+</sup> burst is observed within cortical tissue upon singular pillar displacement. The playback rate is 75 fps. Scale = 200 µm. Clip 3: Force sensing of an *A. thaliana* G-CaMP3 root growing in the bi-dfRC observation channel over 2.5 hours, under steady flow (20 µL/min) of ½ MS/0.31 mM MES media at the shoot site through inlets A and B adjoining at the root differentiation zone. A directional Ca<sup>2+</sup> burst is observed following the displacement of both the pillar and guidance array. The playback rate is 75 fps. Scale = 200 µm.”

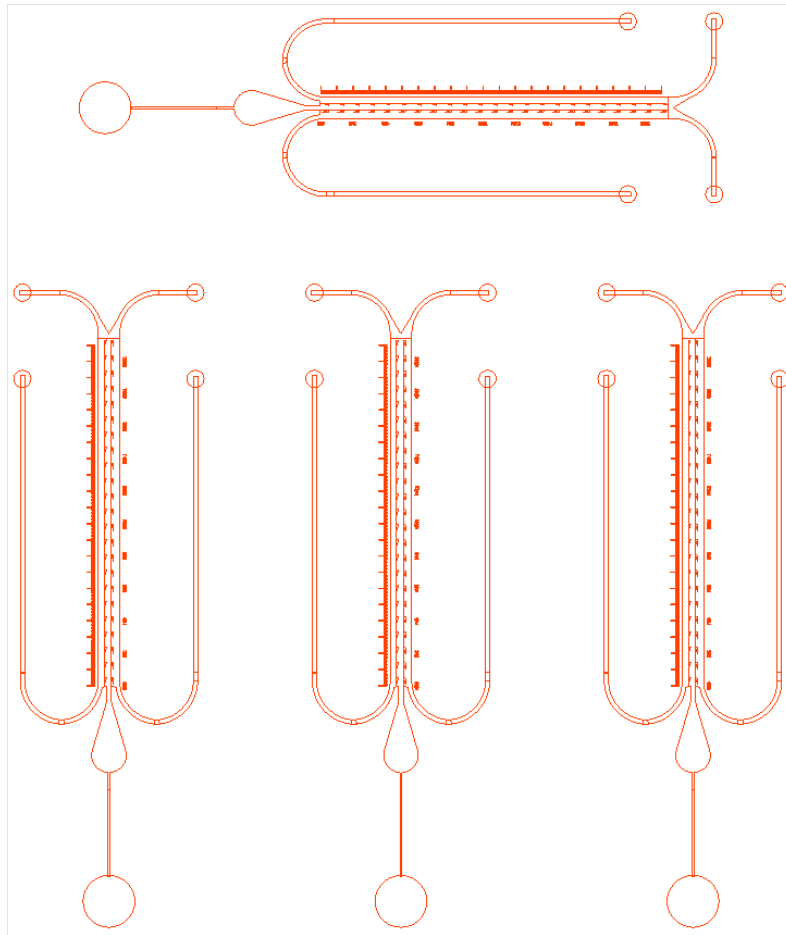
**Movie V5:** “Clip 1: *A. thaliana* root growth in the bi-dfRC observation channel over 2 hours, under steady flow (20 µL/min) of ½ MS/0.31 mM MES media for 1 hour, subsequently switched to 100 mM NaCl treatment for 1 hour at the shoot site through inlets A and B adjoining at the root differentiation zone. The playback rate is 30 fps. Scale = 200 µm. Clip 2: *N. benthamiana* root growth in the bi-dfRC observation channel over 2 hours, under steady flow (20 µL/min) of ½ MS/0.31 mM MES media for 1 hour, subsequently switched to 100 mM NaCl treatment for 1 hour at the shoot site through inlets A and B adjoining at the root differentiation zone. Scale = 200 µm. Clip 3: *S. lycopersicum* root growth in the bi-dfRC observation channel over 2 hours, under steady flow (20 µL/min) of ½ MS/0.31 mM MES media for 1 hour, subsequently switched 100 mM NaCl treatment for 1 hour at the shoot site through inlets A and B adjoining at the root differentiation zone. Scale = 200 µm.”

**Movie V6:** “Clip 1: An *A. thaliana* G-CaMP3 root exposed to *P. capsisci* cell suspension with motile zoospores through the root site inlet C of the bi-dfRC, localised at the root tip. Initiation of a fast Ca<sup>2+</sup> signal, G-CaMP3 fluorescence (GFP) is observed upon treatment localisation to the root tissue. *P. capsisci* spore localisation (RFP) is observed at the root hairs within 1 min, and again, in the bi-dfRC microchannel within 15 min. The original 30 min video has been set to 20 fps, for visualisation purposes. Scale bar, 232 µm. Clip 2: An *A. thaliana* Orp1\_roGFP root exposed to *P. capsisci* cell suspension with motile zoospores through the root site inlet C of the bi-dfRC, localised at the root tip. Gradual build-up of H<sub>2</sub>O<sub>2</sub>, Orp1\_roGFP fluorescence (GFP) is observed upon treatment localisation, over 30 min. Zoospore localisation (RFP) is observed at the root hairs within 1 min, then again at the elongation/maturation zone of the primary root within 20 min. The original 30 min video has been set to 20 fps, for visualisation purposes. Scale bar, 232 µm. Clip 3: An *A. thaliana* Col0-0 (wild type, WT) root exposed to *P. capsisci* cell suspension with motile zoospores through the root site inlet C of the bi-dfRC, localised at the root tip. No signals are observed prior to and upon zoospore localisation (RFP) to the root hairs and elongation/maturation zone of the primary root within 5 min. The original 30 min video has been set to 20 fps, for visualisation purposes. Scale bar, 232 µm.”

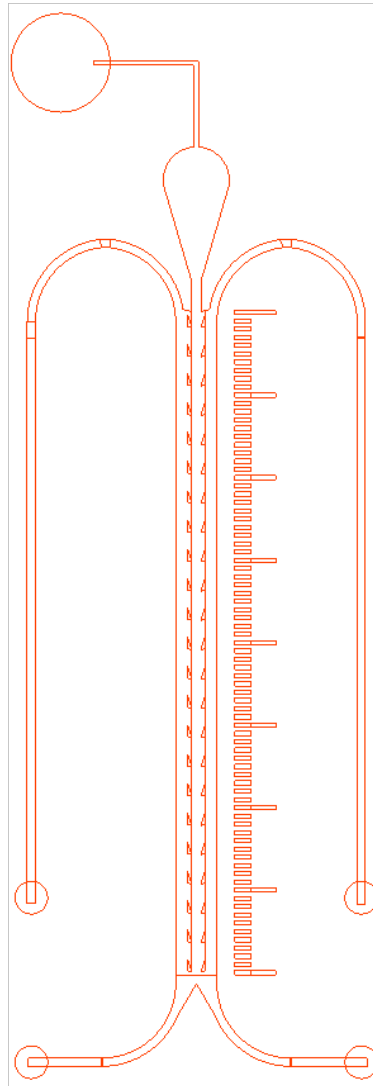
### Part III: Supplementary mask files



File CAD 1: "Photolithography mask for the *A. thaliana* chip."

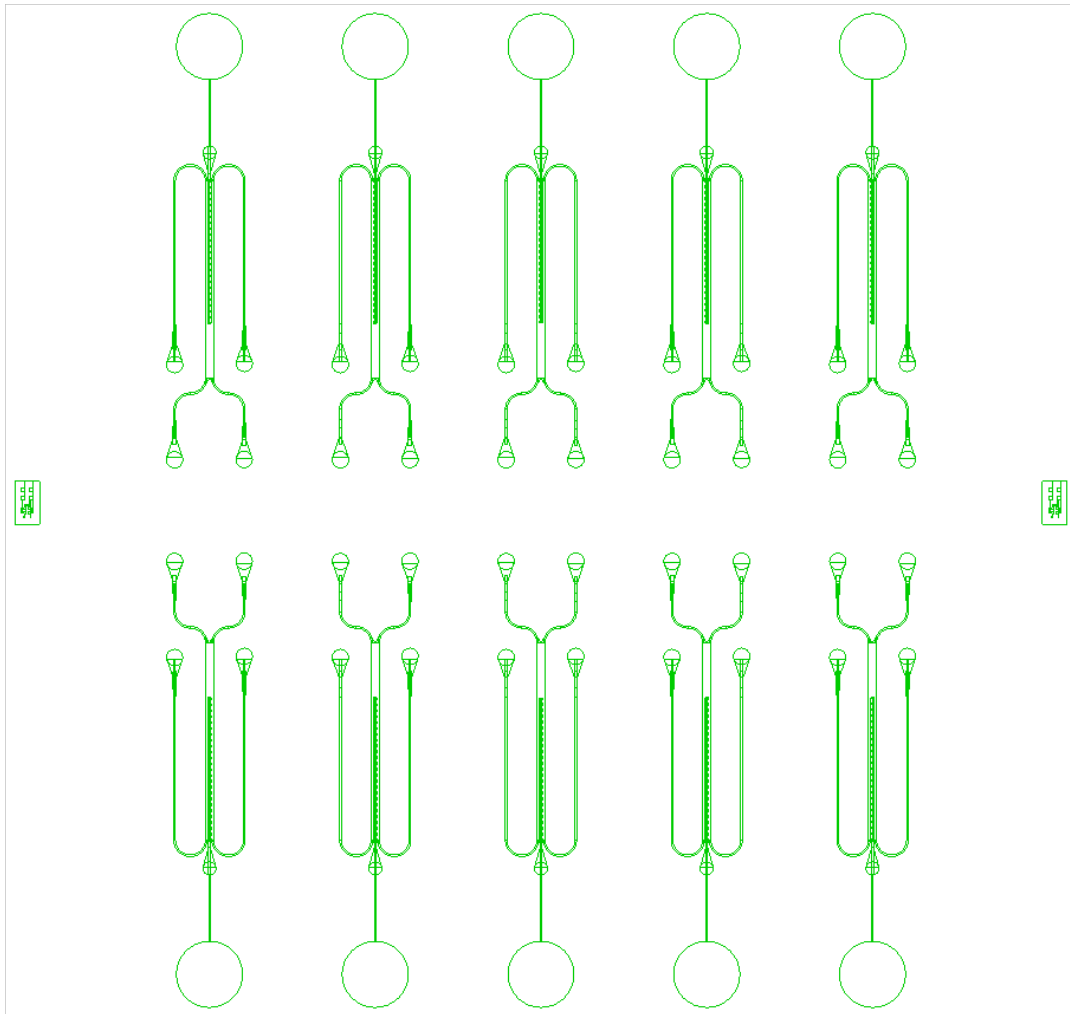


File CAD 2: "Photolithography mask for the *N. benthamiana* chip."

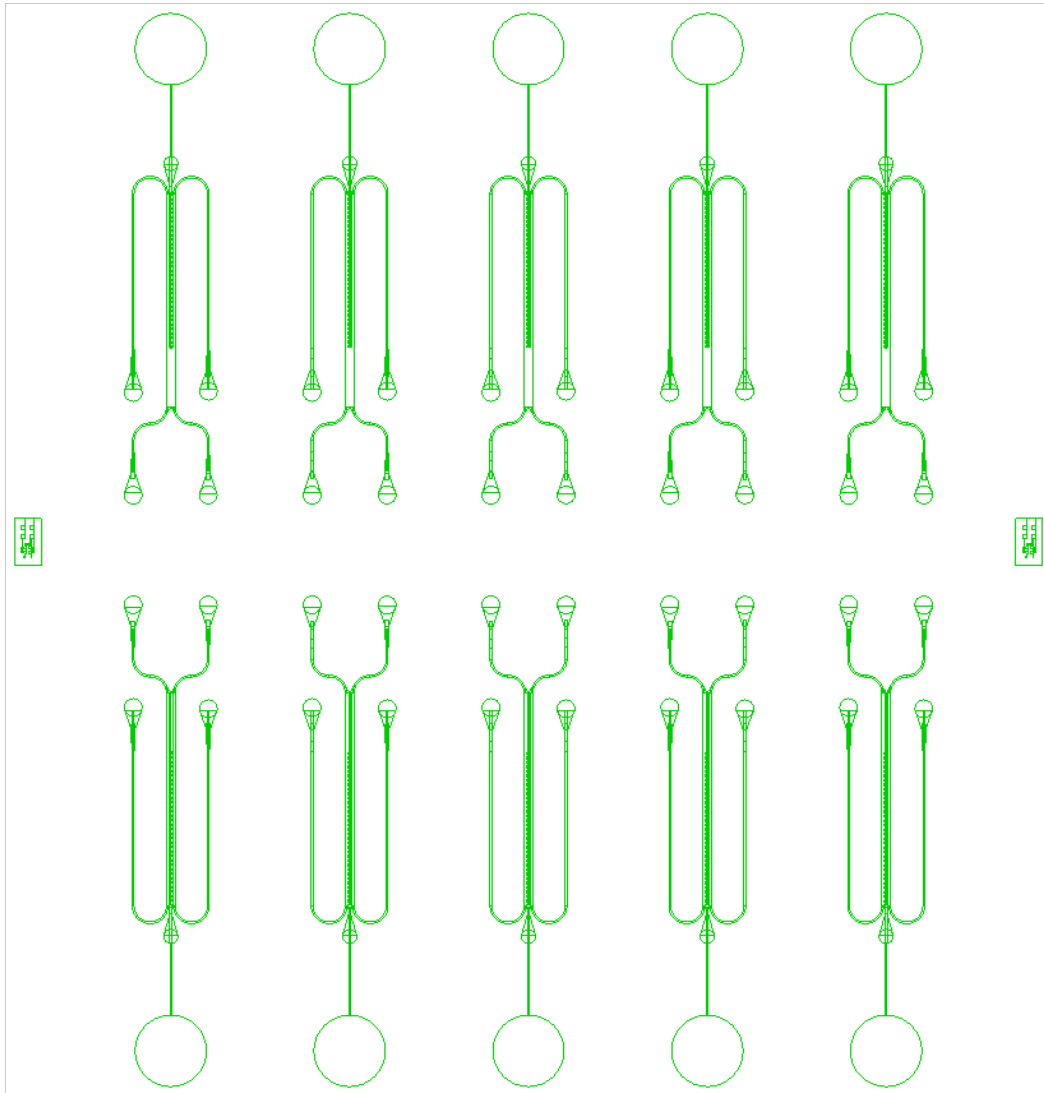


File CAD 3: "Photolithography mask for the *S. lycopersicum* chip."





File CAD 4: "Photolithography mask layer 1 for the *A. thaliana* force sensing chip."



File CAD 5: "Photolithography mask layer 2 for the *A. thaliana* force sensing chip."