

# Energy requirements for two aspects of phospholipid metabolism in mammalian brain

A. David PURDON and Stanley I. RAPOPORT<sup>1</sup>

Laboratory of Neurosciences, National Institutes on Aging, National Institutes of Health, Bethesda, MD, 20892-1582, U.S.A.

Previous estimates have placed the energy requirements of total phospholipid metabolism in mammalian brain at 2% or less of total ATP consumption. This low estimate was consistent with the very long half-lives (up to days) reported for fatty acids esterified within phospholipids. However, using an approach featuring analysis of brain acyl-CoA, which takes into account dilution of the precursor acyl-CoA pool by recycling of fatty acids, we reported that half-lives of fatty acids in phospholipids are some 100 times shorter (min–h) than previously thought. Based on these new estimates of short half-lives, palmitic acid and arachidonic acid were used as prototype fatty acids to calculate energy consumption by fatty acid recycling at the *sn*-1 and *sn*-2 positions of brain phospholipids. We calculated that the energy requirements for reacylation of fatty acids into lysophospholipids are 5% of net brain ATP consumption. We also

calculated ATP requirements for maintaining asymmetry of the aminophospholipids, phosphatidylserine and phosphatidylethanolamine across brain membrane bilayers. This asymmetry is maintained by a translocase at a stoichiometry of 1 mol of ATP per mol of phospholipid transferred in either direction across the membrane. The energy cost of maintaining membrane bilayer asymmetry of aminophospholipids at steady-state was calculated to be 8% of total ATP consumed. Taken together, deacylation–reacylation and maintenance of membrane asymmetry of phosphatidylserine and phosphatidylethanolamine require about 13% of ATP consumed by brain as a whole. This is a lower limit for energy consumption by processes involving phospholipids, as other processes, including phosphorylation of polyphosphoinositides and *de novo* phospholipid biosynthesis, were not considered.

## INTRODUCTION

A considerable portion of ATP consumption by mammalian brain is thought to be required by the Na<sup>+</sup>/K<sup>+</sup> cation pump for redistribution of 4–5 μmol of Na<sup>+</sup>/g of brain/min [1]. This calculation is based on the observed decrease by approximately 50% in resting oxygen consumption following addition of ouabain to rat brain slices [2,3]. However, more recent analyses, including further scrutiny of 'ouabain-sensitive O<sub>2</sub> consumption', have lowered the cation-pump requirement to 25–40% of net brain-ATP utilization [4]. This revised estimate indicates that 60–75% of ATP consumed by brain is for processes other than operation of the Na<sup>+</sup>/K<sup>+</sup> pump.

Phospholipid metabolism has long been considered to require low amounts of ATP, and only approximately 2% of brain glucose flux has been estimated to support lipid synthesis [5]. To a large degree, brain phospholipid metabolism has been perceived as very slow. Half-lives (*t*<sub>1/2</sub>), which describe the kinetics of metabolic precursors within phospholipid compartments, were reported to be many hours or days [6]. However, when recycling of metabolic intermediates was taken into account more recently, half-lives of fatty acids within phospholipids were shown to be much shorter, of the order of hours to minutes [7–9]. Estimates of ATP consumption for deacylation–reacylation reactions involving phospholipids must be correspondingly increased.

In estimating fatty acid half-lives in phospholipids, attention has been focused on the metabolic role of brain acyl-CoA, the precursor pool for acylation of fatty acids into lysophospholipids [7]. During intravenous infusion of radiolabelled unesterified palmitic acid or arachidonic acid in awake rats, the level of radiolabel in the brain acyl-CoA pool was found to reach a steady-state with regard to the plasma unesterified fatty acid-

specific activity within only 2 min [8,9]. Furthermore, at steady-state the acyl-CoA pool had considerably lower specific activity than plasma (≈ 1–2%), indicating considerable dilution of tracer by unlabelled fatty acids derived largely from phospholipids in brain, due to actions of phospholipases A<sub>1</sub> or A<sub>2</sub> or phospholipase C/diglyceride lipase. When this dilution was taken into account, half-lives of fatty acids in brain phospholipid were considerably shorter than without this correction. An unesterified fatty acid must be activated to acyl-CoA before the fatty acid can be incorporated into brain phospholipid by the action of acyl-transferase. Activation requires acyl-CoA synthetase and consumption of ATP [10]. The high rates of fatty acid incorporation into phospholipids and much shorter half-lives evident from our work [8,9], suggest that energy consumption by activation is higher than assumed previously.

Another metabolic process involving phospholipids and requiring ATP has been elucidated recently. Based on observations on red blood cells [11,12], which have been extended to other cell types and to membranes of intracellular compartments, asymmetry in the distribution of phospholipids across the plasma membrane has been recognized. Neutral phospholipids [sphingomyelin and phosphatidylcholine (PC)] and charged aminophospholipids [phosphatidylethanolamine (PE) and phosphatidylserine (PS)] are concentrated on opposite sides of the phospholipid membrane bilayer [13,14]. A translocase which transfers phospholipids across the bilayer has been purified and shown to function in model membrane systems [15]. This translocase has been cloned and structural data on it are available [16]. It is a P-type ATPase that requires Mg-ATP and can be inactivated by vanadate [17,18]. The aminophospholipid translocase requires ATP to transfer a phospholipid from one side of the bilayer to the other [13,14]. Given the extent of membrane

Abbreviations used: PC, phosphatidylcholine; PS, phosphatidylserine; PE, phosphatidylethanolamine.

<sup>1</sup> To whom correspondence should be addressed (e-mail SIR@Helix.nih.gov).

compartments in brain, and the propensity of integral membrane proteins [19] and natural membrane processes [20] to dissipate phospholipid asymmetries, maintenance of phospholipid asymmetry across brain membranes may consume a significant part of the ATP used by brain cells.

Because of these new considerations, we thought it important in this paper to estimate the contributions to total ATP consumption by brain of both deacylation–reacylation reactions of phospholipids and maintenance of aminophospholipid membrane asymmetries. Our results suggest that these aspects of brain phospholipid metabolism consume about 13% of net ATP consumed by brain.

## ANALYSIS OF DATA

### Net rate of ATP consumption by brain

ATP consumption by mammalian brain can be estimated in several ways, all of which give an approximate value of 7 mmol/min for human brain. This value, however, may be some 25% or more higher or even significantly lower, but will be used for estimating the relative rate of consumption ascribed to processes of lipid metabolism in this paper.

One reliable estimate is that of Clark and Sokoloff [5], who derived ATP consumption from the measured rate of net oxygen consumption by a 1400 g human brain of 49 ml of O<sub>2</sub>/min. Assuming that almost all brain oxygen is used for oxidation of carbohydrates (the value actually is about 90% [21]), and a 20% efficiency of energy conversion for the synthesis of the high-energy phosphate bonds of ATP (which has an energy of hydrolysis of 7 kcal/mol), the energy equivalent of this rate of synthesis is 0.25 kcal/min. Accordingly, the rate of ATP consumption by a 1400 g human brain is 7.1 mmol/min [5]:

$$(0.25 \text{ kcal/min}) \times 0.20 \times (1000 \text{ mmol/7 kcal}) = 7.1 \text{ mmol of ATP/min} \quad (1)$$

Another way to estimate ATP consumption by human brain is to recognize again that glucose is the preferred substrate for the oxygen used for the reoxidation of NADH, and in principle will yield 2.5 ATP per O atom consumed. This value of 2.5 is considered to represent the best estimate of a 'mechanistic' P/O ratio [22]. Taking the stated oxygen consumption (49 ml/min/1400 g) as 2.18 mol/min/g and assuming that with glucose as substrate most oxygen is used in the reoxidation of NADH, one can calculate ATP consumption at 10.9 mmol of ATP/min/g, which is 50% higher than the value of Clark and Sokoloff [5]. However, the mechanistic P/O ratio can be used to estimate the actual or 'effective' P/O ratio *in vivo* by taking into account the fraction of tissue oxygen consumption (i) involved with non-mitochondrial oxygen consumption ( $\approx 10\%$ ) and (ii) coupled to the proton leak ( $\approx 20\%$ ), both values being estimated from heart, skeletal muscle and liver [23]. With these approximations the 'effective' tissue P/O ratio is calculated as  $0.7 \times 2.5 = 1.75$ . Thus the net rate of ATP consumption by the human brain becomes:

$$\left( \frac{49 \text{ ml of O}_2}{22.4 \text{ ml/mmol}} \right) \times (2 \text{ mol of O/mol of O}_2) \times (1.75 \text{ mol of P/mol of O}) = 7.7 \text{ mol of ATP/min} \quad (2)$$

This number is virtually identical to the estimate of 7.1 mmol of ATP/min/1400 g of brain, and the latter value will be used for later calculations. This rate is equivalent to 83 nmol of ATP/s/g.

Furthermore, because ATP consumption is estimated to be 2.5 times higher in rat brain than in human brain [24], ATP consumption by rat brain approximates to:

$$(83 \text{ nmol/s/g}) \times 2.5 = 208 \text{ nmol/s/g of brain} \quad (3)$$

These human and rodent values will be used in this paper to estimate the relative ATP consumption by two lipid related processes.

### ATP consumption by fatty acid turnover in brain phospholipid

Rate of fatty acid incorporation into membrane phospholipids

Pathways for brain fatty acid metabolism are illustrated in a scheme shown in Figure 1(A). The brain unesterified fatty acid pool may receive input from the unesterified fatty acid fraction in plasma after dissociation from albumin, the plasma esterified fatty acid fraction (receptor-mediated endocytosis of lipoprotein), brain *de novo* fatty acid biosynthesis or fatty acid released from brain membrane phospholipids by phospholipase action. The plasma unesterified fatty acid fraction would include unesterified fatty acid released from lipoprotein into the vascular compartment by lipoprotein lipase. The arachidonic acid component of brain unesterified fatty acids also may be metabolized to form prostaglandins, but it mainly is converted to acyl-CoA through the action of acyl-CoA synthetase, which requires ATP [9]. Molecules of the acyl-CoA pool can be incorporated into brain phospholipids by acyltransferases or subjected to  $\beta$ -oxidation (mainly the saturated fatty acid) in mitochondria or peroxisomes [7]. Furthermore, we have found that the esterified fatty acid fraction in plasma does not contribute measurably to the brain unesterified fatty acid pool [25], and others have shown that the rate of *de novo* fatty acid biosynthesis in brain is low [26]. Therefore, the brain unesterified fatty acid pool has two main inputs, plasma unesterified fatty acids (after dissociation from albumin) and fatty acids released from brain phospholipids by phospholipases.

Our laboratory has developed a method to quantificate rates of fatty acid incorporation into and turnover within brain lipids in awake animals [7]. This approach utilizes the fatty acid model shown in Figure 1(B), a simplification of the complicated metabolic map of Figure 1(A). The net fatty acid flux from the acyl-CoA pool into brain lipids is defined as  $J_{FA}$ . The acyl-CoA pool receives input from the plasma unesterified fatty acid pool ( $J_1$ ) and from brain membrane phospholipids after release by phospholipase activity ( $J_3$ ) [7], and thus  $J_{FA} = J_1 + J_3$ .  $J_2$  (not shown) represents unesterified fatty acid released from a covalent linkage in lipoprotein following lipoprotein uptake by receptor-mediated endocytosis, which we have found is insignificant in the awake adult rat [25].  $J_{met}$  (not shown) represents the portion of the acyl-CoA pool that undergoes  $\beta$ -oxidation. The unidirectional rate of incorporation of  $J_{FA}$  from the brain acyl-CoA pool into stable brain lipids is given as:

$$J_{FA} = c_{br}^*(T) \int_0^T (c_{br,acyl-CoA}^* / c_{br,acyl-CoA}) dt \quad (4)$$

where  $c_{br}^*(T)$  is the concentration of the labelled fatty acid in brain phospholipids at time  $T$  after tracer administration, and  $\int_0^T (c_{br,acyl-CoA}^* / c_{br,acyl-CoA}) dt$  is the integrated specific activity of tracer in the precursor acyl-CoA pool.  $c_{br,acyl-CoA}^*$  and  $c_{br,acyl-CoA}$  represent precursor pool concentrations of labelled and unlabelled acyl-CoA molecular species, respectively.

During programmed infusion of a fatty acid tracer to establish a constant plasma tracer concentration, specific activities of both unesterified radiolabelled fatty acid in plasma and brain acyl-

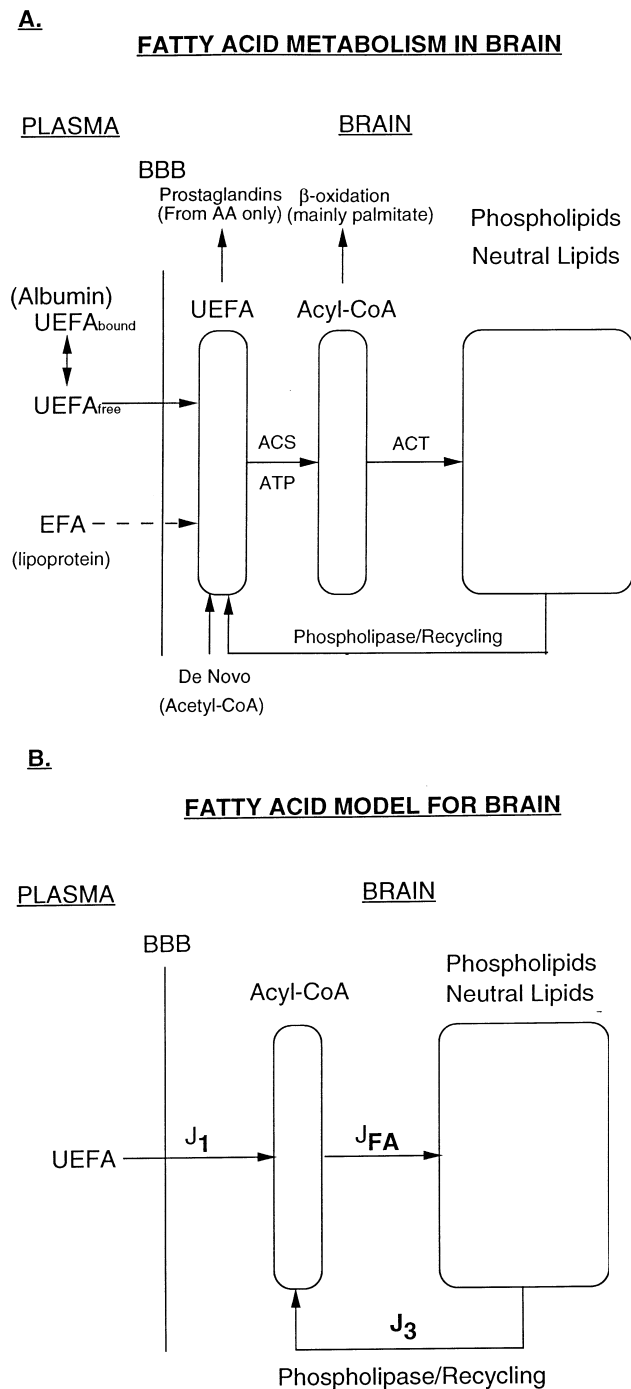

**Figure 1** Fatty acid metabolism in brain

(A) The brain unesterified fatty acid pool receives contributions from brain phospholipase-induced recycling of fatty acid, brain *de novo* input and the plasma esterified (EFA) and unesterified plasma fatty acids (UEFA). The direct contribution of EFA from plasma is very low [25]. Formation of acyl-CoA by acyl-CoA synthetase (ACS) is the ATP-dependent step, whereas incorporation of the fatty acid into the phospholipid by acyltransferase (ACT) does not require ATP. Fatty acids are lost to  $\beta$ -oxidation (mainly palmitate) and to derivitization of arachidonic acid, including prostaglandin formation. (B) Fatty acid model for brain fatty acid metabolism.  $J_{FA}$  is the rate of fatty acid incorporation from the acyl-CoA pool into phospholipid. The main source for brain unesterified acids (including arachidonic acid, AA) is their release by phospholipases from the brain membrane phospholipid itself ( $J_3$ ) and to a lesser extent the unesterified fatty acid pool in plasma ( $J_1$ ). Thus  $J_{FA} = J_1 + J_3$ . BBB, blood brain barrier.

CoA pools reach a steady state in less than 2 min [8,9]. At steady-state, a dilution factor  $\lambda$  is defined as the ratio of specific activities of tracer in the brain acyl-CoA pool to specific activity in the plasma unesterified fatty acid pool [7], and thus:

$$\lambda = [(c_{br,acyl-CoA}^*) / (c_{br,acyl-CoA})] / [(c_{pl}^*) / (c_{pl})] \quad (5)$$

Therefore:

$$J_{FA} = c_{br}^*(T) / \lambda \int_0^T (c_{pl}^* / c_{pl}) dt \quad (6)$$

Under conditions of controlled intravenous infusion of [ $^3$ H]palmitic acid [8] or [ $^3$ H]arachidonic acid [9], the specific activity in the acyl-CoA pool is  $\approx 1-2\%$  (equivalent to  $\lambda = 0.01-0.02$ ) of the specific activity of unesterified radiolabelled fatty acid in plasma. Such low values for  $\lambda$  indicate massive recycling of these fatty acids in brain and justify the pulse approach of our fatty acid model to determine the rate of fatty acid incorporation into brain lipids.

ATP consumption for acyl-CoA formation

2 mol of ATP are consumed for each mol of acyl-CoA that is formed by the catalysis of acyl-CoA synthetase [10]. ATP is converted to AMP and  $PP_i$  during the initial formation of the enzyme-ATP-fatty acid ternary complex and two rounds of phosphorylation are required to regenerate the ATP [10]. Fatty acid is converted to acyl-CoA after the ternary complex reacts with CoA and thus:

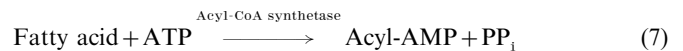

The acyl-CoA can then be incorporated into a lysophospholipid by an acyltransferase to yield a phospholipid without ATP being required [10]:

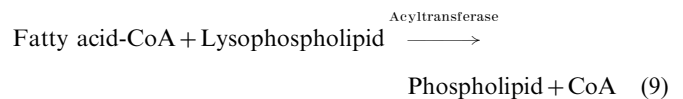

Subsequently, ATP must be replenished by oxidative phosphorylation of glucose.

Rate of fatty acid incorporation at the *sn*-1 position

In the unanaesthetized rat, the  $J_{FA}$  for incorporation of saturated palmitic acid into brain lipid (phospholipid + neutral lipid) is 0.78 nmol/s/g of brain [8]. Palmitate preferentially enters the *sn*-1 position. The unlabelled esterified palmitic acid concentration is 28  $\mu\text{mol/g}$  of brain [27], whereas the total esterified fatty acid concentration is 111.9  $\mu\text{mol/g}$  of brain, with one half of the total in the *sn*-1 position of phospholipids (56  $\mu\text{mol/g}$ ) [27]. If we assume that all palmitate is at the *sn*-1 position of phospholipids (exceptions are small amounts in the *sn*-3 position of triacylglycerols and in cholesterol ester fatty acid), then palmitic acid represents half of the net fatty acid at the *sn*-1 position [i.e. 28  $\mu\text{mol/g}$  (56  $\mu\text{mol/g}$  at *sn*-1) = 0.5]. Most other *sn*-1 fatty acids are saturated, with stearic acid being the main component. We can now estimate ATP consumption due to turnover of the *sn*-1 fatty acids (mostly saturated). If rates of incorporation of the rest of the fatty acids approximate that of palmitate,  $J_{FA}$  of fatty acids into the *sn*-1 position is  $2 \times 0.78$  nmol/s/g of brain, or 1.56 nmol/s/g of brain.

Rate of fatty acid CoA incorporation at the *sn*-2 position

Fatty acids at the *sn*-2 position of phospholipids are largely polyunsaturated, and include arachidonic acid and docosahexaenoic acid.  $J_{FA}$  for incorporation of arachidonic acid into total lipid (phospholipid + neutral lipid) of rat brain is 0.72 nmol/s/g of brain [9]. Furthermore, all arachidonic acid is at the *sn*-2 position of phospholipids. The concentration of arachidonic acid esterified in lipids is 11.3  $\mu$ mol/g of brain, equal to 20% of the 56  $\mu$ mol/g of fatty acids in the *sn*-2 position [27]. Letting the remaining *sn*-2 fatty acids have the same rate of incorporation as arachidonic acid,  $J_{FA}$  for *sn*-2 unsaturated fatty acids is 0.72 nmol/s/g  $\times$  5 = 3.60 nmol/s/g of brain.

ATP consumption of acylation of lysophospholipid

The net rate of incorporation of fatty acids into both the *sn*-1 and *sn*-2 positions of total brain phospholipid is:

$$1.56 (sn-1) \text{ nmol/s/g} + 3.6 (sn-2) \text{ nmol/s/g} = 5.2 \text{ nmol/s/g of brain} \quad (10)$$

2 mol of ATP are consumed per mol of fatty acid converted to acyl-CoA prior to its incorporation into phospholipid (Equations 7–9). Therefore, the rate of ATP consumption by rat brain to maintain unidirectional rates of incorporation into the *sn*-1 and *sn*-2 positions of phospholipids is:

$$5.2 \text{ nmol of fatty acid/s/g} \times 2 = 10.4 \text{ nmol of ATP/s/g of brain.} \quad (11)$$

This value represents 5.0% of the estimated rate of total 208 nmol/s/g of ATP consumption by rat brain.

### ATP consumption for maintenance of membrane phospholipid asymmetry

Phospholipid disposition in membranes

There are gross differences in the composition of membranes in the intracellular and plasma membrane compartments [13]. In general, most PS, sphingomyelin and cholesterol are concentrated in the plasma membrane, whereas most PC is found in membranes of the endoplasmic reticulum [13]. These distributions have been thoroughly analysed for BHK cells, which can help in specifying phospholipid distribution in brain [28]. Endocytic vesicles and the plasma membranes account for approximately 30% of cell membrane phospholipid, which includes 65% of the total PS. Only 20% of PS is in the endoplasmic reticulum [28], the remainder is in the Golgi compartment and lysosomes. It is likely that all phospholipid in the endoplasmic reticulum is symmetrically disposed, due to randomization by a non-ATP-requiring protein in the endoplasmic reticulum [29] acting on phospholipid synthesized *de novo* on the cytosolic membrane surface [30]. The remainder of the PS is probably located on the cytosolic surface of the membrane bilayer. The distribution of aminophospholipids and neutral phospholipids on opposite sides of the membrane bilayer is due to ATP-linked action of the aminophospholipid translocase [13,14]. We take the PS concentration in rat brain as 9  $\mu$ mol/g [31] and assume that all PS, excluding the 20% in the endoplasmic reticulum,  $0.8 \times 9 = \approx 7 \mu$ mol/g, is maintained asymmetrically by the translocase on the cytosolic surface. Thus, PS is essentially absent from the outer leaflet of the plasma membrane where its presence would initiate pathological sequelae [13]. We extend this conclusion to intracellular membranes as well and assume that PS is almost exclusively found on one side of the membrane bilayer in membrane compartments where translocase is active.

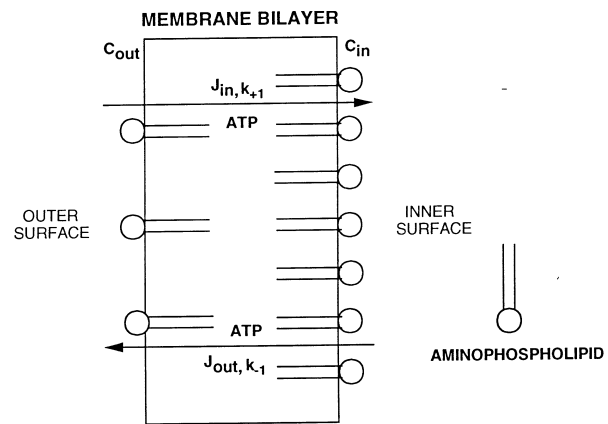

**Figure 2** Membrane model bilayer with the aminophospholipids (PS and PE) asymmetrically disposed on either side of the bilayer

The aminophospholipids are concentrated on the interior surface. The outward–inward transfer rates, defined by  $k_{+1}$ , and the inward–outward transfer rates, defined by  $k_{-1}$ , define the steady-state levels of aminophospholipids on the interior and exterior sides of the bilayer.  $J_{in}$  and  $J_{out}$  represent rates of transport of aminophospholipids across the membrane bilayer.

On the other hand, PE is found in all membrane compartments, with 30% in the plasma membrane and 20% in the endoplasmic reticulum [13,28]. The remainder is in nuclear (5%), Golgi (10%), lysosomal (10%) and mitochondrial (25%) membranes [13,28]. Mitochondrial membranes [32], along with endoplasmic reticulum discussed previously, probably do not have phospholipid asymmetry [13,32]. We assume that the remaining 55% of PE (i.e. 14.1  $\mu$ mol/g) is asymmetrically maintained by the translocase and is distributed as in the red-blood-cell plasma membrane (85% inner surface, 15% outer surface, ratio = 5.71), which gives  $(25.7 \mu\text{mol} \times 0.55) \times 0.85 = 12.0 \mu\text{mol/g}$  on the cytoplasmic side of the bilayer and  $(25.7 \times 0.55) \times 0.15 = 2.1 \mu\text{mol/g}$  on the opposite surface [13,14,32].

Stoichiometry between ATP consumption and aminophospholipid translocation

In red cells, the aminophospholipid translocase can be inhibited by ATP depletion or by vanadate [13,14,32]. In plasma membrane vesicles from red blood cells, transfer of aminophospholipids has been correlated with ATP consumption, with approximately 1 mol of ATP being consumed per mol of PS transferred [33]. This same stoichiometry can probably be extended to PE and used to estimate the energy cost of maintaining asymmetries of PS and PE in brain membranes.

ATP consumption by phospholipid translocation

Analysis of fluxes of spin-labelled phospholipids in human red-blood-cell membranes has provided unidirectional rate constants for bidirectional fluxes of PE and PS [34]. Bitbol and Devaux [34] found that phospholipid movements in both directions require ATP. The distribution of phospholipids is shown in Figure 2 for a membrane bilayer. In this Figure,  $k_{+1}$  and  $k_{-1}$  represent rate constants ( $s^{-1}$ ) for inward (outside  $\rightarrow$  inside) and outward fluxes, respectively.  $k_{-1}$  for the outward flux of aminophospholipids is smaller than  $k_{+1}$  for the inward flux and transfer of aminophospholipids from the side having the higher concentration (inside) would dissipate membrane phospholipid asymmetry. Bidirectional transfer has been assumed for some time, and the translocase itself may show such activity *in vitro* [35].

**Table 1** Steady-state rates of aminophospholipid transfer across the membrane bilayer

Nomenclature is for 1,2-diradyl glycerophospholipids and includes the 1,2-diacyl and ether phospholipids for choline- and ethanolamine-containing glycerophospholipids. Values for  $k_{-1}$  were taken from Bitbol and Devaux ([34], Table 1) whereas values for  $k_{+1}$  were calculated. Values for  $k$  and  $J$  given are mean  $\pm$  S.D.

Phospholipid	$C$ (nmol/g)	$k$ ( $s^{-1}$ )	$J$ (flux) (nmol/s/g)
PE	$C_{in} = 12000$	$k_{-1} = 1.50 \pm 0.3 \times 10^{-4}$	$J_{out} = 1.8 \pm 0.4$
PE	$C_{out} = 2100$	$k_{+1} = 8.57 \pm 1.9 \times 10^{-4}$	$J_{in} = 1.8 \pm 0.4$
PS	$C_{in} = 7000$	$k_{-1} = 2.00 \pm 0.3 \times 10^{-4}$	$J_{out} = 1.4 \pm 0.2$
PS	$C_{out} \approx 0$	Very high	$J_{in} = 1.4 \pm 0.2^*$

\* Value extrapolated from  $J_{out}$  value for PS assuming a steady-state (Equation 14).

To illustrate these issues with regard to Figure 2, we define influx of aminophospholipid as:

$$J_{in} = k_{+1} C_{out} \quad (12)$$

and efflux in the opposite direction as:

$$J_{out} = k_{-1} C_{in} \quad (13)$$

At steady state:

$$J_{in} = J_{out} \quad (14)$$

For PE, where  $C_{in}$  and  $C_{out}$  are  $12.0 \mu\text{mol/g}$  and  $2.1 \mu\text{mol/g}$ , respectively (see above):

$$\frac{k_{+1}}{k_{-1}} = \frac{C_{in}}{C_{out}} = 5.71 \quad (15)$$

Bitbol and Devaux [34] have reported for PE:

$$k_{-1} = 1.50 \times 10^{-4} s^{-1} \quad (16)$$

and therefore from Equation 15:

$$k_{+1} = 8.57 \times 10^{-4} s^{-1} \quad (17)$$

As expected at steady-state (Equation 14), and as shown in Table 1,  $J_{in}$  and  $J_{out}$  calculated from Equations 12 and 13 for PE are both equal to  $1.8 \text{ nmol/s/g}$ .

Using  $k_{-1}$  equal to  $2 \times 10^{-4} s^{-1}$  for PS, as reported by Bitbol and Devaux [34] for human red blood cells, and the value of  $C_{in}$  for PS discussed previously ( $7 \mu\text{mol/g}$ ),  $J_{out}$  for PS is calculated as  $1.4 \text{ nmol/s/g}$  (Table 1) using Equation 13.  $C_{out}$  for PS is effectively zero. However, at steady-state  $J_{in}$  must also equal  $1.4 \text{ nmol/s/g}$ .

Given the 1:1 stoichiometry between phospholipid flux and ATP consumption, we calculate total ATP consumption for the bidirectional transfer of PE as  $3.6 \text{ nmol/s/g}$  and of PS as  $2.8 \text{ nmol/s/g}$ . Thus, the rate of ATP consumption for maintaining the asymmetry of the aminophospholipids across the membrane bilayer is  $6.4 \text{ nmol/s/g}$ . These calculations were based on rate constants obtained from human red blood cells. As ATP consumption by human brain equals  $83 \text{ nmol/s/g}$  (see above), assuming species specificity, we calculate that  $7.7\%$  of brain ATP consumption goes to maintain membrane asymmetry of the aminophospholipids, PE and PS.

## DISCUSSION

We have estimated that deacylation–reacylation reactions at the *sn*-1 and *sn*-2 positions of rat brain phospholipids consume  $5\%$  of total brain ATP, assuming a net rate of ATP consumption in rat brain of  $208 \text{ nmol}$  of ATP/s/g of brain. Acyltransferase

activity purified from brain [36] favours the re-incorporation of arachidonic acid compared with other fatty acids (e.g. oleic acid) at the *sn*-2 position of 1-acyl-2-lyso phospholipids. Oleate is a major substrate, in addition to arachidonate, in well-characterized brain acyltransferase systems [37,38]. Phospholipase  $A_1$  activity has also been found in brain and evidence exists for lysolecithinase activity as well [39]. More recently, a novel approach featuring incorporation of  $^{18}\text{O}$  to mark deacylation–reacylation events showed half-lives of less than 60 min for most molecular species of phospholipid in rat liver [40]. These results confirm rapid deacylation–reacylation at both the *sn*-1 and *sn*-2 positions of phospholipids, as there are no gross differences in rates of deacylation–reacylation at the *sn*-1 and *sn*-2 positions based on fatty acid type. Recently, a rapid incorporation of docosahexanoic acid into brain phospholipid has been found that is comparable with the rate of incorporation for arachidonic acid (M. Chang, personal communication). Therefore, an assumption of this analysis, that incorporation rates for palmitic acid [8] and arachidonic acid [9] can be extrapolated to include all deacylation–reacylation reactions at the *sn*-1 and *sn*-2 positions, is probably valid and can be used to give an estimate for ATP consumption by such processes.

We also calculated that maintenance of membrane asymmetry of PE and PS consumes about  $8.0\%$  of brain ATP production. An ATP-requiring translocase has been reported in a number of tissue subcompartments, including the synaptosomal subcompartment in brain [41]. It maintains phospholipid asymmetry across the membranes of a number of cellular compartments [13,14,32]. For PE, the asymmetry ratio approximates 5.71 [12–14,32] (see Equation 15). Based on the findings for synaptosomes, and on the presence of translocase and membrane-bilayer asymmetry in a large number of cellular systems, we assume that phospholipid asymmetry extends throughout the membranes of the mammalian brain and that it is maintained by the aminophospholipid translocase. A number of factors argue for ubiquitous symmetry of membrane PS and PE in brain. Synaptosomes have been shown to have PS and PE exposed toward the cytosol [41], which helps to permit fusion to the plasma-membrane bilayer where similar orientation of PS and PE can be expected [35,42]. In turn, it is known that  $\text{Ca}^{2+}/\text{K}^{+}$  ATPase [43] and  $\text{Na}^{+}/\text{K}^{+}$  ATPase [44] need PS to function. Therefore, the secretory and ion-controlling machinery of the cell depends on the membrane disposition of aminophospholipids.

PS and PE are usually found concentrated on one side of a membrane bilayer. Moving them across the bilayer consumes 1 mol of ATP per mol of phospholipid transferred [33]. Rates of dissipation of this membrane phospholipid asymmetry are reported for the human red blood cell [34,35]. We made a number of assumptions to determine the ATP requirement for maintaining membrane phospholipid asymmetry in human brain. One is the ATP-dependent bidirectionality of the translocase. We calculated  $J_{out}$  (rate of flopping) from the  $k_{-1}$  rate constant, determined by Bitbol and Devaux [34] on the assumption that this parameter describes the rate at which the membrane phospholipid asymmetry is dissipated, and used  $J_{out}$  to calculate values of  $J_{in}$  at steady-state. Two separate groups have demonstrated the Mg-ATP-dependent requirement of  $J_{out}$  and  $J_{in}$  for the aminophospholipids [34,35]. Our steady-state flux value  $J_{in} = 1.8 \text{ nmol} \cdot \text{s}^{-1} \cdot \text{g}^{-1}$  found for PE is calculated from a higher  $k_{+1}$  value  $8.57 \times 10^{-4} s^{-1}$  (Table 1) than that determined experimentally by Bitbol and Devaux [34] (i.e.  $3.3 \times 10^{-4} s^{-1}$ ). A thorough theoretical analysis [20] indicates a considerable passive flux of aminophospholipid driven by concentration gradients across the bilayer, which may account for this discrepancy between the values of Bitbol and Devaux and the steady-state

value calculated here (Table 1). Such perturbations of bilayer asymmetry may affect the transfer rates based on our steady-state calculations. The apparent lack of measurable PS on the plasma-membrane exterior precludes direct calculation of  $J_{in}$  for PS. We ignored asymmetry of PC in the plasma membrane, which also may be maintained by translocase, thereby further augmenting ATP consumption [34,35].

Taken together, our analyses suggest that brain phospholipid metabolism and maintenance of asymmetries of PS and PE across membranes require a significant (13% or more) portion of net brain ATP production. Additional membrane processes involving phospholipids may elevate this estimate, including maintenance of PC membrane asymmetry, *de novo* phospholipid biosynthesis (which requires ATP for *de novo* fatty acid biosynthesis), generation of phosphatidic acid from glucose and formation of phospholipids [6]. In general, *de novo* biosynthesis is assumed to be low in adult brain [6]. However, when recycling of intermediates was taken into account, an apparently high rate of 32 nmol/s/g of brain was calculated for *de novo* biosynthesis of total brain ethanolamine plasmalogen [45]. Preliminary calculations indicate that total *de novo* phospholipid biosynthesis would account for a significant additional amount of ATP consumption ( $\approx 6\%$  of total) if comparable rates of turnover were found for the large amount of 1,2-diacyl phospholipids. Another consideration is the high rate of turnover of the inositol-4 and inositol-5 phosphates on the polyphosphoinositides. This turnover in platelets is reported to account for 7% of total ATP consumption [46]. Brain has greater amounts of polyphosphoinositides than platelets on a per g of protein basis and thus energy requirements should be at least comparable. However, based on incorporation of [ $^{32}$ P]P<sub>i</sub> into membrane phospholipids of brain slices, Pumphrey [47] claimed that both the *de novo* pathway and formation of the polyphosphoinositides in brain consume low amounts of ATP. This older work deserves to be reconsidered, as recycling of phospholipid intermediates was ignored, and in brain slices ATP concentration and turnover may be considerably disturbed and decreased.

Additionally, when recycling of phospholipid metabolic intermediates is considered for other pathways (e.g. recycling of choline), long half-lives previously reported for such metabolic intermediates [6] may prove to be inordinately over-estimated. Thus ATP consumption would be increased correspondingly. If this is so, phospholipid metabolism will be recognized as a more dynamic process in brain than assumed previously, and would be found to consume an even more significant portion of ATP. Sensitivity of membrane homeostasis to energy failure (e.g. ischaemia) would also have to be considered as an important component in neuropathology, implicating new routes for pharmacological intervention.

## REFERENCES

- Lowry, O. H. (1975) In Brain Work; the coupling of function, metabolism and blood flow in the brain. Proceedings of the Alfred Benzon Symposium VIII, Copenhagen May 1974, (D. H. Ingvar and N. A. Lassen eds.), pp. 48–63. Munksgaard rd, Copenhagen
- Whittam, R. and Blond, D. M. (1964) *Biochem. J.* **92**, 147–158
- Whittam, R. (1962) *Biochem. J.* **82**, 205–212
- Albers, R. W., Siegel, G. J. and Stahl, W. L. (1994) In Basic Neurochemistry: Molecular, Cellular, and Medical Aspects, 5th edn., (Siegel, G. J., ed.), pp. 49–73, Raven Press, New York
- Clark, D. D. and Sokoloff, L. (1994) In Basic Neurochemistry: Molecular, Cellular, and Medical Aspects, 5th edn., (Siegel, G. J., ed.), pp. 645–680, Raven Press, New York
- Porcellati, G., Goracci, G. and Arienti, G. (1983) *Lipid Turnover* **13**, 277–293
- Robinson, P. J., Noronha, J., De George, J. J., Freed, L. M., Nariai, T. and Rapoport, S. I. (1992) *Brain Res. Rev.* **17**, 187–214
- Grange, E., Deutsch, J., Smith, Q. R., Chang, M. C., Rapoport, S. I. and Purdon, A. D. (1995) *J. Neurochem.* **65**, 2290–2298
- Washizaki, K., Smith, Q. R., Rapoport, S. I. and Purdon, A. D. (1994) *J. Neurochem.* **63**, 727–736
- Waku, K. (1992) *Biochim. Biophys. Acta* **1124**, 101–111
- Seigneuret, M. and Devaux, P. F. (1984) *Proc. Natl. Acad. Sci. U.S.A.* **81**, 3751–3755
- Zachowski, A., Fellmann, P. and Devaux, P. F. (1985) *Biochim. Biophys. Acta* **815**, 510–514
- Williamson, P. and Schlegel, R. A. (1994) *Mol. Membr. Biol.* **11**, 199–216
- Diaz, C. and Schroit, A. J. (1996) *J. Membr. Biol.* **151**, 1–9
- Auland, M. E., Roufogalis, B. D., Devaux, P. F. and Zachowski, A. (1994) *Proc. Natl. Acad. Sci. U.S.A.* **91**, 10938–10942
- Tang, X., Halleck, M. S., Schlegel, R. A. and Williamson, P. (1996) *Science* **272**, 1495–1497
- Moriyama, Y., Nelson, N., Maeda, M. and Futai, M. (1991) *Arch. Biochem. Biophys.* **286**, 252–256
- Xie, X., Stone, D. K. and Racker, E. (1989) *J. Biol. Chem.* **264**, 1710–1714
- De Kruijff, B., Van den Besselaar, A. M. H. P., Van den Bosch, H. and Van Deenen, L. L. M. (1978) *Biochim. Biophys. Acta* **514**, 1–8
- Heinrich, R., Brumen, M., Jaeger, A., Muller, P. and Herrmann, A. (1997) *J. Theor. Biol.* **185**, 295–312
- Siesjo, B. K. (1978) *Brain Energy Metabolism*, Wiley, Chichester
- Hinkle, P. C., Kumar, M. A., Resetar, A. and Harris, D. L. (1991) *Biochemistry* **30**, 3576–3582
- Rolfe, D. F. S. and Brown, G. C. (1997) *Physiol. Rev.* **77**, 731–758
- Sokoloff, L., Reivich, M., Kennedy, C., Des Rosiers, M. H., Patlak, M. H., Pettigrew, K. D., Sakurada, O. and Shinohara, M. (1977) *J. Neurochem.* **28**, 897–916
- Purdon, A. D., Arai, T. and Rapoport, S. I. (1997) *J. Lipid Res.* **38**, 158–162
- Cook, H. W. (1978) *J. Neurochem.* **30**, 1327–1334
- Rehncrona, S., Westerberg, E., Akesson, B. and Siesjo, B. K. (1982) *J. Neurochem.* **38**, 84–93
- Allan, D. (1996) *Mol. Membr. Biol.* **13**, 81–84
- Herrmann, A., Zachowski, A. and Devaux, P. F. (1990) *Biochemistry* **29**, 2023–2027
- Bishop, W. R. and Bell, R. M. (1985) *Cell* **42**, 51–60
- Wells, M. A. and Dittmer, J. C. (1967) *Biochemistry* **10**, 3169–3174
- Zachowski, A. (1993) *Biochem. J.* **294**, 1–14
- Beleznyay, Z., Zachowski, A., Devaux, P. F., Navazo, M. P. and Ott, P. (1993) *Biochemistry* **32**, 3146–3152
- Bitbol, M. and Devaux, P. F. (1988) *Proc. Natl. Acad. Sci. U.S.A.* **85**, 6783–6787
- Connor, J., Pak, C. H., Zwaal, R. F. A. and Schroit, A. J. (1992) *J. Biol. Chem.* **267**, 19412–19417
- Deka, N., Sun, G. Y. and MacQuarrie, R. A. (1986) *Arch. Biochem. Biophys.* **246**, 554–563
- Baker, R. R. and Chang, H. Y. (1981) *Biochim. Biophys. Acta* **666**, 223–229
- Masuzawa, Y., Sugiura, T., Sprecher, H. and Waku, K. (1989) *Biochim. Biophys. Acta* **1005**, 1–12
- Pete, M. J., Wu, D. W. and Exton, J. H. (1996) *Biochim. Biophys. Acta* **1299**, 325–332
- Schmid, P. C., Johnson, S. B. and Schmid, H. H. O. (1991) *J. Biol. Chem.* **266**, 13690–13697
- Zachowski, A. and Gaudry-Talarmin, Y. M. (1990) *J. Neurochem.* **55**, 1352–1356
- Glaser, P. E. and Gross, R. W. (1995) *Biochemistry* **34**, 12193–12203
- Ford, D. A. and Hale, C. C. (1996) *FEBS Lett.* **394**, 99–102
- Roelofsen, B. and van Deenen, L. L. M. (1973) *Eur. J. Biochem.* **40**, 245–257
- Masuzawa, Y., Sugiura, T., Ishima, Y. and Waku, K. (1984) *J. Neurochem.* **42**, 961–968
- Verhoeven, A. J. M., Tysnes, O., Aarbakke, G. M., Cook, C. A. and Holmsen, H. (1987) *Eur. J. Biochem.* **166**, 3–9
- Pumphrey, A. M. (1969) *Biochem. J.* **112**, 61–70