

## Selective Electrofusion of Conjugated Cells in Flow

Tom C. Bakker Schut, Yvonne M. Kraan, Wim Barlag,\* Lou de Leij,\* Bart G. de Grooth, and Jan Greve

Department of Applied Physics, Applied Optics Group, University of Twente, 7500 AE Enschede; \*Department of Internal Medicine, Clinical Immunology Group, University of Groningen, 9713 ES Groningen, the Netherlands

**ABSTRACT** Using a modified flow cytometer we have induced electrofusion of K562 and L1210 cells in flow. The two cell types are stained with two different fluorescent membrane probes, DiO and DiI, to facilitate optical recognition, and then coupled through an avidin-biotin bridge. In the flow cytometer, the hydrodynamically focused cells and cell pairs are first optically analyzed in a normal flow channel and then forced to flow through a Coulter orifice. If the optical analysis indicates that a cell pair is present, an electric pulse is applied across the orifice to induce fusion. The pulsed cell pairs were subsequently analyzed using normal and confocal microscopy to evaluate fusion induction. It appears that fusion can be induced in about 10% of pulsed cell pairs when one electric pulse with a duration of 10–15  $\mu$ s and an effective electric field strength of 4–8  $10^5$  V/m is used.

### INTRODUCTION

Pairs of different cells can be fused to become hybrid cells by means of one or more electric field pulse(s) (Zimmerman, 1982). This process is called electrofusion. The hybrid cell is not necessarily stable since it may lose chromosomes, die, or fall apart again in separate cells. If the fused cell is stable the eventual daughters will be hybrid and have a combination of the characteristics of the original cells (Goding, 1982). The optimum field strength to induce fusion is dependent on both the size of the cell and the cell types used (different cells can have different membrane breakdown voltages (Bates et al., 1987)). If electrofusion is induced in bulk after cell pairing using dielectrophoresis (Zimmerman, 1982), pure one-to-one fusions are achieved only to a limited extent. Dielectrophoresis results in long strings of cells (pearl-chains) in random order. This reduces the chances of one-to-one fusion of two different cells.

Another way to establish close contact between two cells is by linking them chemically, as done by Lo (Lo et al., 1984) and Tomita (Tomita and Tsong, 1990). Using biotin-avidin bridging, specific pairs of antigenic-based preselected B lymphocytes and myeloma cells could be made, which were subsequently fused directly with an electric field pulse, without prior dielectrophoresis. This appears to be a very effective way for selectively fusing cells.

A drawback of chemical linking is, first, that not all cell pairs will be aligned with the electric field lines of the applied pulse. This results in less effective field distributions in the contact zones between the cells. Second, if the population of cells to be fused does not have a uniform size distribution, a number of large cells will die because the voltage pulse may be too high and a number of cells will not fuse because the voltage pulse may be too low. This is also a problem in the fusion procedure using dielectrophoresis. One way to over-

come the above disadvantages is to fuse prelinked cell pairs in a sequential electrofusion procedure, using an optimal alignment and an optimal electric field strength.

In this article a possible way to achieve sequential electrofusion at high rates is investigated. We have developed a modified flow cytometer in which we can selectively electroporate cells on the basis of an optical analysis of the cells. This set-up can be used as a damaging sorter by applying a very high electric field pulse to the unwanted cells, as has been demonstrated (Bakker Schut et al., 1990). In the present report we examine the possibility of using this flow cytometer as a fusion sorter by selectively fusing cell pairs that have been made using biotin-avidin coupling. As a test system we use K562 (human erythroblast cell line) and L1210 (mouse lymphocyte cell line) cells. These cells are chosen because they can be easily maintained as single cell suspension cultures. Using this set-up, we are able to fuse pairs of these cells with an efficiency of up to 10% using a single electric field pulse.

### MATERIALS AND METHODS

#### Chemicals

Streptavidin was obtained from Boehringer Mannheim (catalog 973-190, Mannheim, Germany). Test-Neuraminidase was obtained from Behring (Marburg, Germany). The fluorescent markers DiO (D275 or DiOC<sub>18</sub>), excitation at 484 nm, emission at 501 nm) and DiI (D282 or DiIC<sub>18</sub>(3), excitation at 550 nm, emission at 565 nm) were obtained from Molecular Probes (Eugene, OR). NHS-LC-Biotin was obtained from Pierce (Oud Beijerland, The Netherlands). RPMI 1640 and fetal calf serum were obtained from GIBCO (Gaithersburg, MD).

#### Cell lines

K562 and L1210 cells were maintained as suspension cultures in RPMI 1640 + 10% fetal calf serum, supplemented with 2 mM L-glutamine, 100 units of penicillin/ml, and 100 mg/ml streptomycin. In the case of the L1210 cells 60  $\mu$ M mercaptoethanol was also present in the medium. Cell lines are grown at 37°C in a humidified atmosphere of 5% CO<sub>2</sub> in air.

#### Preparation of cell pairs

Cell pairs were formed using an avidin-biotin coupling, following an adapted version of the procedure, originally developed by Lo (1984). Before

Received for publication 18 March 1993 and in final form 5 May 1993.

Address reprint requests to B. G. de Grooth, Department of Applied Physics, University of Twente, P.O. Box 217, 7500 AE Enschede, The Netherlands. Tel.: 31-53-893157; Fax: 31-53-309549.

© 1993 by the Biophysical Society

0006-3495/93/08/568/05 \$2.00

coupling, the K562 cells ( $10^6$  cells/ml) were stained using DiI (stock solution of 4 mg/ml dimethyl sulfoxide, 1 ml/ml cell suspension), the L1210 cells ( $10^6$  cells/ml) were stained using DiO (stock solution of 2.5 mg/ml, 2 ml/ml cell suspension) by incubating for 1 h at 37°C in a humidified atmosphere of 5% CO<sub>2</sub> in air. DiO and DiI are incorporated in the membranes of the cell and some of the organelles within the cell like the mitochondria and the endoplasmatic reticulum.

After staining, the cells were washed twice with phosphate-buffered saline (PBS) and brought to a concentration of  $10^7$  cells/ml. Cells were then treated with neuraminidase (acylneuraminyl hydrolase, 3 ml/ $10^6$  cells at a final concentration of 1 unit/ml), during 30 min at 37°C, in order to remove negatively charged sugar residues from the membrane (it hydrolyses *O*-ketoside  $\alpha$ 2-3,  $\alpha$ 2-6, and  $\alpha$ 2-8 bonds of terminal *N*-acetylneuraminic acids). After removal of dead cells (by centrifugation over a fetal calf serum cushion) and washing twice with PBS, cells were biotinylated by incubating the K562 and L1210 cells with 10  $\mu$ g of NHS-LC-biotin/ $10^6$  cells (using a concentration of 1 mg/ml freshly prepared NHS-LC-biotin in PBS), at room temperature for 2 and 1 h, respectively. After incubation, an equal volume of fetal calf serum was added for 10 min, to remove non-cell NHS-LC-biotin. All cells were washed twice with PBS and then resuspended in a concentration of  $10^7$  cells/ml. Streptavidin (2.5 mg/ml PBS) was added to the L1210 cells in a concentration of 25 ml/ $10^6$  cells and incubated during 40 min at room temperature. After incubation, the L1210 cells were washed twice with PBS. Equal amounts of K562 cells and L1210 cells were then added in a concentration of about  $10^6$ – $10^7$  cells/ml and incubated for 10–60 min at room temperature. It should be noted that, besides pairs, also triplets and other multiplets can be formed. Concentration and incubation time were varied to give a maximum number of cell pairs without getting too many multiplets. Usually we incubated during 0.5 h at a concentration of  $10^7$  cells/ml. Finally, PBS was added to get a concentration of  $10^6$ /ml.

## Flow cytometry

The modified flow cytometer is described in detail elsewhere (Bakker Schut et al., 1990). Fig. 1 shows a schematic drawing of its set-up. A square flow cell (Hellma GmbH, Germany) with a conical part of 4 mm and a flow

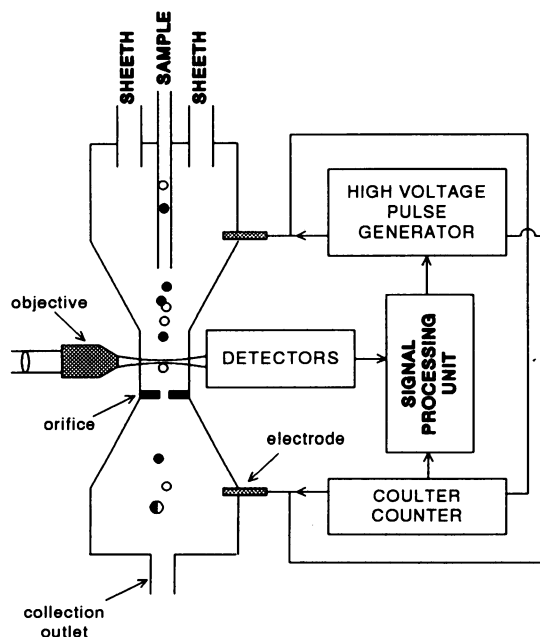

FIGURE 1 Schematic drawing of the set-up used. The signal processing unit is used to selectively trigger the high voltage pulse generator at the moment the pair of cells is inside the orifice. The Coulter counter is used to determine the delay between optical analysis and the moment that the cells arrive at the orifice.

channel of 1 mm was used. Cells are hydrodynamically focused by the conical part of the flow cell. Two adherent cells with similar sizes will be oriented along the direction of flow by the hydrodynamic forces in the funnel of the flow cell (Kachel et al., 1990). As sheath fluid, a 0.9% NaCl solution was used. Light of an argon ion laser (model 5500 AWC, Ion Laser Technology, Salt Lake City, UT), tuned at a wavelength of 488, operated at 50 mW, and polarized parallel to the direction of flow, was focused to an elliptic spot of approximately 3.8 mm in the direction of flow and 100 mm in the direction orthogonal to flow using a cylindrical lens (focal length, 80 mm) and a Leitz 32  $\times$  0.40 objective. Four signals were measured: forward light scattering, the pulse length of the forward scatter signal, green light (510–590 nm, for DiO fluorescence), and orange-red light (>590 nm, for DiI fluorescence). Cell pairs were recognized using a recently developed slit-scan technique (Bakker Schut et al., 1993). Briefly, this technique can be used to measure the separate fluorescence peak heights of two adherent cells on the basis of the forward light scatter signal that always shows two peaks when a cell pair passes the slit illumination. After optical analysis, the cells flow through an orifice with a diameter of 80  $\mu$ m and a length of 100  $\mu$ m. The construction of the flow cell is such that, if a pulse is applied at the electrodes, the voltage drop will mainly occur across the orifice (highest resistance) and only the cells that are inside the orifice will experience a high field strength electric pulse (see Bakker Schut et al. (1990) for details). If a pair of cells is detected on the basis of the pulse duration of the forward scatter signal, the signal processing unit will trigger the high voltage pulse generator (0–1000 V, square pulse, duration 10–120  $\mu$ s, 50% rise time at 500 V = 1  $\mu$ s). The electric voltage pulse is applied after a suitable delay time, in order to coincide with the moment that the cell pair is inside the orifice. The cells can be recollected at the outlet of the flow cell.

The electric field strength inside the orifice as a function of the applied voltage  $V_A$  was calculated to be  $0.4 \times 10^4 \times V_A$  V/m (7). Pulse durations are determined by flow speed inside the orifice; in all cases the pulse length exceeds the time that the cells are inside the orifice. The duration of the electric pulse, experienced by the cell, can be calculated to be approximately  $O/Q$  seconds, where  $O$  is the cross section of the orifice ( $m^2$ ) and  $Q$  is the volume flow rate ( $m^3/s$ ). The delay time is determined by using the flow cell as a Coulter counter and measuring the time between the optical and the electrical pulse (Bakker Schut et al., 1990).

## Microscopy

Cells were examined and counted using a NIKON Optiphot fluorescence microscope. Blue excitation light (420–490 nm) was used to look at DiO and DiI fluorescence, whereas phase contrast microscopy was used to evaluate cell viability. Cells with ruptured membranes (dead cells) can be identified in this way, because they are not surrounded by the a bright ring, caused by the transition between two media with different refractive indices (in this case the membrane and the outer medium). The presence of the ring does not guarantee, however, that the cells are alive since some cells, stained with ethidium bromide or propidium iodide, may still have this ring. Test measurements using K562 cells, of which about half was killed by electroporation, showed that more than 95% of the cells, indicated as vital using phase contrast microscopy, did not stain with PI.

A Leica Fluovert inverted confocal microscope was used to obtain a three-dimensional image of the fused cells. Excitation was done using the blue (488 nm) and the green (568 nm) line of an argon krypton laser. Simultaneous recordings of the intensities of the green (band pass fluorescein isothiocyanate) and orange-red (>580 nm) light were made, using an oil immersion objective (63  $\times$ , N.A. (numerical aperture) = 1.4). The scan surface was  $40 \times 40 \mu m^2$ , taking an image every micrometer of depth. All images were averaged four times.

## Measurements

All fusion experiments were done with the modified flow cytometer, described above. In all experiments, a volume flow rate of about  $3 \times 10^{-8} m^3/s$  was used, resulting in an average velocity of 0.48 m/s in the flow channel and an average velocity of 6 m/s inside the orifice. Therefore, the optical

illumination time is about 20  $\mu\text{s}$  for a single cell with a diameter of 10  $\mu\text{m}$ . If an electric field is present during the passage through the orifice, the effective electric pulse width is about 10–15  $\mu\text{s}$  for a pair of cells with the same size. The sample rate was about 300 cells/s.

The high voltage pulse was applied to all events that showed an optical pulse duration range of 40–100  $\mu\text{s}$  (all pairs and possible triplets and multiplets). The application of the high voltage pulse is electronically delayed to compensate for the time needed to flow from the place of optical measurement to the orifice. The high voltage pulse had a duration of more than 50  $\mu\text{s}$ . This duration was deliberately chosen higher than the required 10–15  $\mu\text{s}$  to compensate for eventual jitter in the delay between optical measurement and arrival in the orifice (the typical delay time is about 200  $\mu\text{s}$ ). The height of the voltage pulse was varied to determine the optimum value.

Cells were collected at the outlet of the flow cytometer by connecting a tube to the outlet and letting the cells gently flow into a test tube. After centrifugation for 5 min at 130 g (at room temperature), the pellet was resuspended and examined using fluorescence and phase contrast microscopy. The numbers of fused cells, single cells, pairs, and triplets or multiplets, were counted and compared with the numbers of respective events in the original sample.

## RESULTS

In the fusion sorter each individual cell is optically analyzed in a quartz flow channel. When a cell pair is detected, fusion induction of the cells is attempted by applying an electrical field pulse when the pair passes the orifice at the end of the flow channel. In a model system we examined in the present paper the possibilities for inducing fusion of biotin-avidin coupled pairs of K562 and L1210 cells.

Fig. 2 gives the number of fused cells and the number of pairs, present in the treated sample, relative to the amount of pairs, present in the original sample. Only the living (judged by phase contrast) cells were counted. The number of pairs (and multiplets) varied between 10 and 25% of the total amount of events.

The confocal microscope was used to obtain a three-dimensional image of the fused cells. This was done to get

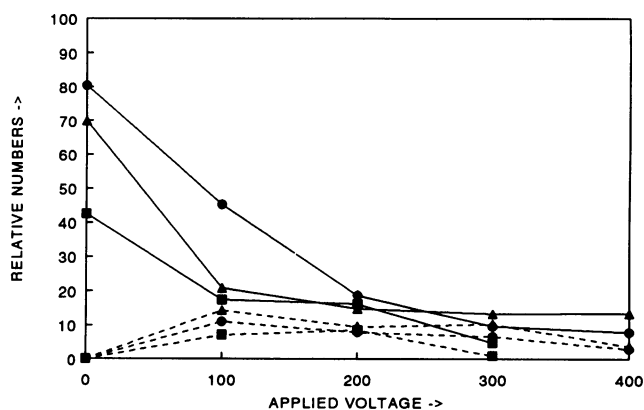

FIGURE 2 Number of fusion products, obtained by fusion in flow (dashed lines) and the number of remaining cell pairs (solid lines), normalized to the number of cell pairs (and multiplets) in the original sample, as a function of the applied voltage. Three different experiments are shown; dots: 25% pairs, and triplets in the original sample; triangles: 12.7% pairs, and triplets in the original sample; squares: 17.1% pairs, and triplets in the original sample.

an impression of the distribution of the two fluorescent probes. Fig. 3 A shows two reconstructed three-dimensional images of a cell pair, at different angles (stereo views, 10° difference in viewing angle). Fig. 3 B shows two reconstructed three-dimensional images of a fusion product obtained with the fusion sorter using a 100-V pulse ( $4 \times 10^5$  V/m, 10–15- $\mu\text{s}$  effective pulse duration).

## DISCUSSION

The present experiments were devised to investigate whether electrofusion of avidin-biotin-coupled cells in flow is possible or not. The results show that fusion percentages of 10% (of the coupled cells) can be achieved using one pulse with a duration of 10–15  $\mu\text{s}$  and an effective electric field strength of 4–8  $10^5$  V/m. There appears to be a broad range of field strengths that lead to fusion products which may be explained by the fact that the L1210 cells have a large variation in size, leading to a large variation of matching optimal pulse heights. This also in agreement with the observation that hybrid cells, which were fused with low field strengths, have larger diameters than cells fused with higher field strengths.

The relative amount of cell pairs that were found to become fused is high, considering the nonoptimal circumstances in which fusion was induced (shear forces in the flow cell, nonoptimal fusion medium). In addition, these cells are different in size and are reported to give low fusion yields (Sowers, 1992). As these first experiments were devised to investigate only the possibility of selective fusion in flow, no conclusions with respect to the survival of the fusion products and their eventual expected functioning can be made. There are, however, no apparent reasons to presume that the fusion products that survive, would behave differently from normal electrofusion products.

An important reason for the obtained high fusion yields may be the presence of a large area of contact between the cells, due to the coupling with avidin-biotin (see Fig. 3 A). The fusion yield proved to be dependent for a major part on the degree of coupling of the cells: when the cells were strongly coupled (high amount of avidin-biotin), the contact area between the cells was large and the fusion yield was concurrently high. It can be also seen from Fig. 2 that the lowest fusion yields were obtained, when the relative amount of pairs, present in the sample not treated with an electric pulse, was lowest.

A possible negative aspect about electrofusion in flow might be that the cells are subject to shear forces at a moment that they are particularly weak. Our experiments with the electrodamaging sorter (Bakker Schut et al., 1990) showed that cells can easily survive these shear forces while being electroporated. It can be seen from Fig. 2 that it is possible to recover 80% of the original amount of pairs and triplets, if no electric pulse is given. It should be noted that expressing the amounts of pairs and triplets, present in the sample after flowing through the fusion sorter, as percentages of the originally present pairs and triplets, is a somewhat uncertain meas-

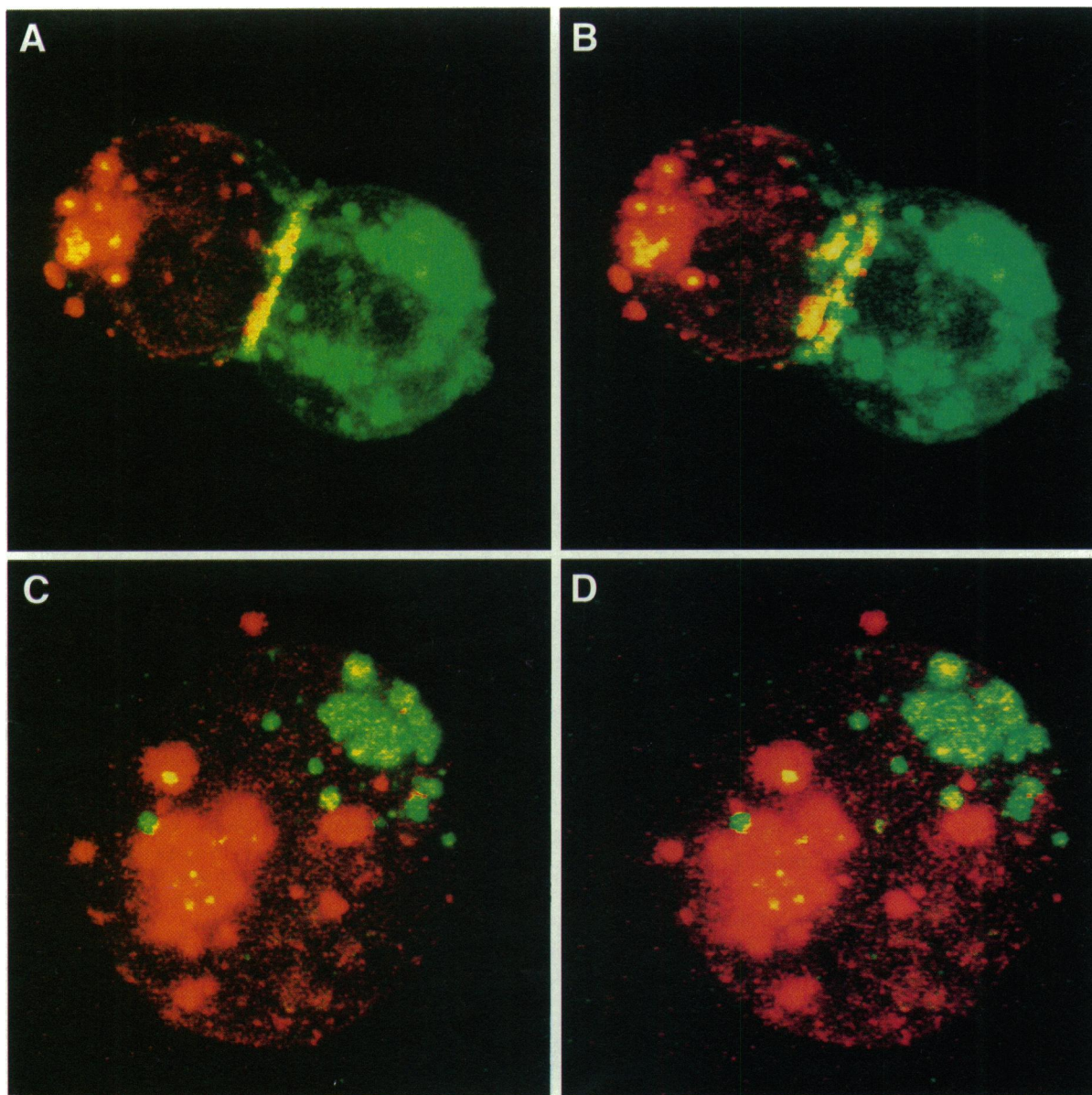

FIGURE 3 Three-dimensional images at two different angles (stereo views,  $10^\circ$  difference in viewing angle) obtained with a confocal microscope. The cells are stained with DiO, and DiI. (A) A cell pair before fusion; (B) A fusion product obtained by fusion in flow with a 100-V pulse ( $4 \times 10^5$  V/m, 10–15  $\mu$ s).

urement, because triplets and multiplets can disrupt and give pairs and single cells. The amount of triplets and other multiplets in the samples used in these experiments varied between 10–15% of the total amount of pairs and triplets.

The influence of the fusion medium (0.9% NaCl-solution, i.e., physiological salt solution) on the fusion yield was not investigated. Physiological salt solution was used, because it is a simple medium, in which cells can survive while being electroporated; it is a conductive medium which is not usable for bulk fusion experiments (because of low dielectrophoretic forces and sample heating due to large currents) but it can be used, and it is in fact necessary in the present set-up for making Coulter counter measurements (Bakker Schut et al., 1990).

The three-dimensional images of the fusion product, constructed from confocal images, clearly show that the rounded up morphology is present. The size of the fusion product is also significantly larger than that of the parental cells. Most of the fluorescence seems to be internalized and localized near the membrane. The DiO fluorescence on the membrane is clearly visible, there is also DiI fluorescence (*green*) on the membrane, but this is hardly visible because the DiI fluorescence inside the cell has a much higher intensity than the DiI fluorescence on the membrane. It can be seen from Fig. 3 B that the two different fluorescent probes inside the fusion product are still segregated, indicating that the organelles did not mix. The most plausible reason for this is that the fluorescent probes are incorporated into organelles that are con-



nected to the membrane (endoplasmic reticulum, mitochondria) and that these organelles do not mix in the first 15–30 min after fusion, during which the confocal images were obtained.

The fusion inducement rates we achieved were about 30–75 pulsed pairs/s. With a yield of 10%, this equals 180–450 fusions/min. The yield of fusion in flow may be further improved by changing the medium, using size-dependent pulse heights and improved coupling techniques. In the present paper, we simply pulsed all the cell pairs. It is in principle possible, by improving the signal processing to pulse only pairs that satisfy certain criteria. Such criteria could be combinations of fluorescent markers. In addition, selectively killing of the single cells is also possible, thus producing a sample with only optimally pulsed cell pairs. The sample rate that can be used, is limited by the time needed for optical analysis. For a cell pair, this time is approximately 50–100  $\mu$ s, resulting in a maximum sample rate of 10,000–20,000 cells (or cell pairs)/s. With a coupling efficiency of 25% and a fusion yield of 10% this would give a maximum rate of 2,500–5,000 fusions/s.

A more scientific advantage of controllable sequential fusion of large numbers of cells, would be the study of electrofusion of individual cell pairs. The process of electrofusion, and the influence of the different parameters on the fusion yield, is still not understood (Sowers, 1992). Partly, this is caused by the fact that the number of parameters is large (dependent on type of cells, media, and electrical parameters) and results partly from the fact that most information is obtained from bulk experiments. In many of these experiments, dielectrophoresis was used to align the pairs, which poses restrictions on the choice of the fusion media. This has led to a number of misconceptions about the fusion process, as mentioned by Sowers (1992). A second disadvantage of using dielectrophoresis for establishing close contact is that the number of cells that is fused to form one cell

cannot be controlled. This may be another factor which influences fusion yield without being properly recognized.

It can be concluded that sequential detection and electrofusion in the fusion sorter can be used to promote the process of electrofusion of individual pairs, using large numbers of cells. Optimization of the process will show whether or not it is competitive with bulk fusion in terms of fusion yield of viable hybridomas per amount of time.

We like to thank Anne Marie van Leeuwen for obtaining the images with the confocal microscope. This investigation was supported by a grant from the Dutch Ministry of Economic Affairs.

## REFERENCES

- Bakker Schut, T. C., B. G. de Grooth, and J. Greve. 1990. A new principle of cell sorting using selective electroporation in a modified flow cytometer. *Cytometry*. 11:659–666.
- Bakker Schut, T. C., A. Florians, K. Radošević, B. G. de Grooth, and J. Greve. 1993. Signal processing in slit-scan flow cytometry of cell conjugates. *Cytometry*. 14:459–464.
- Bates, G. W., J. A. Saunders, and A. E. Sowers. 1987. Electrofusion principles and applications. *In Cell Fusion*. A. E. Sowers, editor. Plenum Publishing Corp., New York. 367–395.
- Goding, J. W. 1982. Production of monoclonal antibodies by cell fusion. *In Antibody as a Tool*. J. J. Marchalonis, and G. W. Warr, editors. John Wiley & Sons Ltd., New York. 273–289.
- Kachel, V., H. Fellner-Feldegg, and E. Menke. 1990. *In Flow Cytometry and Sorting*. 2nd ed. M. R. Melamed, P. F. Mullaney, and M. L. Mendelsohn, editors. J. Wiley & Sons, Inc., New York. 27–44.
- Lo, M. M. S., T. Y. Tsong, M. K. Conrad, S. M. Strittmatter, L. D. Hester, and S. H. Snyder. 1984. Monoclonal antibody production by receptor-mediated electrically induced cell fusion. *Nature (Lond.)*. 310:792–794.
- Sowers, A. E. 1992. Mechanisms of electroporation and electrofusion. *In Guide to Electroporation and Electrofusion*. D. C. Chang, B. M. Chassy, J. A. Saunders, and A. E. Sowers, editors. Academic Press, Inc., San Diego. 119–138.
- Tomita, M., and T. Y. Tsong. 1990. Selective production of hybridoma cells: antigenic-based pre-selection of B-lymphocytes for electrofusion with myeloma cells. *Biochim. Biophys. Acta*. 1055:199–206.
- Zimmermann, U. 1982. Electric field mediated fusion, and some related electrical phenomena. *Biochim. Biophys. Acta*. 694:227–277.