

90. A Steam Distillation Apparatus Suitable for Micro-Kjeldahl Analysis

By Roy Markham, *Plant Virus Research Station and Molteno Institute, Cambridge*

(Received 30 July 1942)

The apparatus to be described is a simple and efficient steam distillation apparatus. Originally designed for the distillation of volatile fatty acids, it has proved very convenient for micro-Kjeldahl analyses.

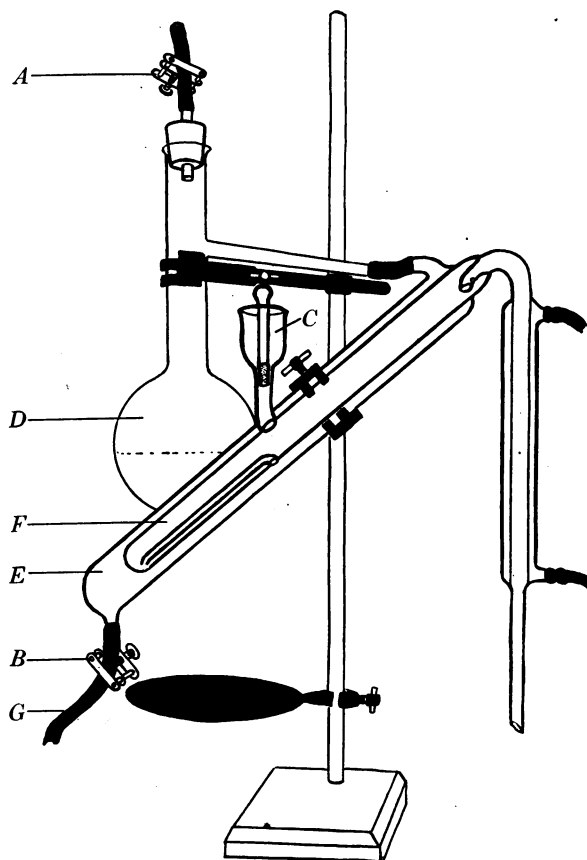

Fig. 1. The steam-distillation apparatus with steam generator and connexions, mounted on a retort stand.

Basically similar to the Pregl apparatus with its many modifications, it differs in some structural details, the result being a compact apparatus with a minimum of rubber connexions, and, as it may be mounted on a single retort stand, it takes up very little bench space.

Fig. 1 shows the apparatus,* which is blown from 'Phoenix' resistance glass.

* Obtainable from Messrs W. G. Flaig and Sons, Ltd., 39 Waterloo Road, Cricklewood, London, N.W. 2.

Operation

The sample to be analysed, containing 0.02–0.15 mg. N, is incinerated in the usual way.

The apparatus is steamed out before operation and the screw clips *A* and *B* are opened. The digest is washed into the apparatus quantitatively with 5–10 ml. distilled water through the funnel *C*, which is fitted with a ground-in stopper. The stopper is replaced and 2 ml. 40% NaOH are poured into the funnel.

The burner is placed under the distillation flask *D*, which serves as a steam generator and is connected to the still by a short rubber connexion. When steam is evolved, screw clip *A* is closed and steam passes into the steam jacket *E*, where it condenses until the liquid in *F* is at 100° when live steam escapes from the tube *G* which leads into a sink.

Screw-clip *B* is then closed and the stopper in the funnel *C* is lifted slightly, letting the strong soda flow into the digest.

Distillation then proceeds, preferably at a rate of 8–10 ml./min. (the condenser is capable of condensing some 10–12 ml./min.). The distillate is collected in a sufficient quantity of dilute acid. When dealing with such small quantities of ammonia it is not desirable to dip the tip of the condenser into the acid. No loss can be detected owing to the small volatility of the dilute ammonia, and the necessity for washing the condenser tip and collecting a larger quantity of distillate is avoided. Practically complete recovery of the ammonia is obtained in 8 ml. of distillate, and it is unnecessary and undesirable to collect more than 10 ml.

When the distillation is complete, the burner is removed and the liquid in *F* flushes automatically into *E*. Water is poured into *C* and washes through into *E*. Clips *B* and *A* are opened, the fluid in *E* runs down the drain and the apparatus is ready for another distillation, the whole operation taking 1–1½ min.

Using *N*/100 HCl with methyl red-methylene blue as indicator and titrating with *N*/100 baryta in a volume of 8 ml., it is possible to judge the end-point of the titration to less than 1% in estimating 0.02 mg. N, and, using 0.03–0.05 mg. N, it is easy to obtain duplicates agreeing to less than 1% without taking any extreme precautions.

When using the apparatus with 0.5 mg. N or more it is recommended that the usual technique of immersing the condenser tip and collecting a larger quantity of distillate should be adopted.

I should like to express my gratitude to my friends E. Benton (now serving with H.M. Forces in the Middle East) and H. W. Hall, technicians in the Biochemical Department, Cambridge, for their assistance.

SUMMARY

A highly efficient steam-jacketed steam distillation apparatus is described.

Details are given of its application to the estimation of quantities of N down to 0.02 mg.