

Mitochondrial Calcium in Relaxed and Tetanized Myocardium

Yoshifumi Horikawa, Ajay Goel, Andrew P. Somlyo, and Avril V. Somlyo

Department of Molecular Physiology and Biological Physics, University of Virginia Health Sciences Center, Charlottesville, Virginia 22906-0011 USA

ABSTRACT The elemental composition of rat cardiac muscle was determined with electron probe x-ray microanalysis (EPMA) of rapidly frozen papillary muscles and trabeculae incubated with ryanodine (1 μM) in either 1.2 or 10 mM $[\text{Ca}^{2+}]_o$ -containing solutions, paced at 0.6 Hz or tetanized at 10 Hz. Total mitochondrial calcium increased significantly, by 4.2 mmol/kg dry weight during a 7 s tetanus, only in muscles tetanized in the presence of 10 mM $[\text{Ca}^{2+}]_o$ when cytoplasmic Ca^{2+} is 1–4 μM (Backx, P. H., W.-D. Gao, M. D. Azan-Backx, and E. Marban. 1995. The relationship between contractile force and intracellular $[\text{Ca}^{2+}]$ in intact rat trabeculae. *J. Gen. Physiol.* 105:1–19). Comparison of total mitochondrial with free mitochondrial Ca^{2+} reported in the literature indicates that the total/free ratio is ~ 6000 at physiological or near-physiological levels of total mitochondrial calcium. Increases in free mitochondrial $[\text{Ca}^{2+}]$ consistent with regulation of mitochondrial enzymes should be associated with increases in total mitochondrial calcium detectable with EPMA. However, such increases in mitochondrial calcium occur only as the result of prolonged, unphysiological elevations of cytosolic $[\text{Ca}^{2+}]$.

INTRODUCTION

Mitochondrial calcium, its concentration, potential physiological role, and definite pathological effects have been the subjects of long-standing and still-debated interest. Early observations showing that isolated mitochondria can accumulate massive amounts of calcium through an electrically driven uniporter led to extensive speculation about their role in relaxation of cardiac and smooth muscle. However, electron probe analysis (EPMA) revealed that in situ such massive accumulations of mitochondrial calcium, usually as hydroxyapatite granules, were present only in damaged cells (cardiac, Somlyo et al., 1975; Eckenhoff and Somlyo, 1989; smooth muscle, Somlyo et al., 1979), and it is now generally agreed that in the normal heart (e.g., Jorgensen et al., 1988; Moravec and Bond, 1991; Keller et al., 1995; Miller and Tormey, 1995), as in other tissues (reviewed in Somlyo et al., 1987; LeFurgey et al., 1988; Gunter et al., 1994; Pozzan et al., 1994; Carafoli et al., 1995), total mitochondrial calcium is low, ~ 1 mmol/kg mitochondrial dry weight or less, and that at normal diastolic levels of cytosolic $[\text{Ca}^{2+}]$ the ratio of matrix-free/cytosolic $[\text{Ca}^{2+}]$ is < 1 (Miyata et al., 1991). Consequently, rapid mitochondrial sequestration of Ca^{2+} is no longer thought to contribute to physiological relaxation during diastole. On the other hand, it is clear that during pathological increases in cytosolic Ca^{2+} mitochondria can serve as high-capacity Ca-sinks, and may alternatively reduce or contribute to the pathological consequences of Ca^{2+} overload resulting from ischemia and

postischemic reperfusion injury (Busselen, 1985; Miller and Tormey, 1995; Miyamae et al., 1996).

The low total (bound plus free) mitochondrial calcium ($[\text{Ca}]_{\text{mt}}$) content in cardiac myocytes and other cells has been suggested to be consistent with free mitochondrial matrix $[\text{Ca}^{2+}]$ concentrations ($[\text{Ca}^{2+}]_{\text{m}}$) in a nonsaturating range that can regulate mitochondrial dehydrogenases under physiological conditions (e.g., Hansford and Castro, 1982; McCormack et al., 1992; reviewed in Gunter et al., 1994). Consequently, recent discussions of mitochondrial calcium shifted to the relationship between cytosolic ($[\text{Ca}^{2+}]_{\text{c}}$) and mitochondrial matrix free Ca^{2+} ($[\text{Ca}^{2+}]_{\text{m}}$) and whether changes in $[\text{Ca}]_{\text{mt}}$ in the contracting heart and other cells are compatible with the role of $[\text{Ca}^{2+}]_{\text{m}}$ in the regulation of mitochondrial metabolism (Moravec and Bond, 1991; Wendt-Gallitelli and Isenberg, 1991; Isenberg et al., 1993; Moravec et al., 1997). These issues have been further complicated by suggestions of spatial heterogeneity of $[\text{Ca}^{2+}]_{\text{m}}$ among mitochondria within a cardiac myocyte (McMillin-Wood et al., 1980; Williford et al., 1990) and other cells (Rizzuto et al., 1994).

The first reliable method to quantitate $[\text{Ca}]_{\text{mt}}$ in situ, EPMA, has a lower detection sensitivity (~ 0.4 mmol/dry mitochondrial weight; Somlyo, 1985; Moravec et al., 1997) than that (nanomolar-to- μM) of fluorescent and luminescent indicators of free Ca^{2+} (Grynkiwicz et al., 1985; Blinks, 1992). Thus, it has been suggested that EPMA “lacks sensitivity” (Miyata et al., 1991), implying that it cannot detect the small physiological changes in $[\text{Ca}]_{\text{mt}}$ associated with changes in $[\text{Ca}^{2+}]_{\text{m}}$. Therefore, we wished to determine the ratio of $[\text{Ca}]_{\text{mt}}/[\text{Ca}^{2+}]_{\text{m}}$ in situ by obtaining EPMA measurements of $[\text{Ca}]_{\text{mt}}$ and relating these to published values of $[\text{Ca}^{2+}]_{\text{m}}$.

In the presence of ryanodine and normal (1.2 mM) or high (10 mM) extracellular $[\text{Ca}^{2+}]_o$, high-frequency electrical stimulation causes prolonged elevation of $[\text{Ca}^{2+}]_{\text{c}}$ up to low μM levels and tetanizes the myocardium (Backx et

Received for publication 14 August 1997 and in final form 17 November 1997.

Address reprint requests to Dr. Avril V. Somlyo, Department of Molecular Physiology and Biological Physics, University of Virginia Health Sciences Center, P.O. Box 10011, Charlottesville, VA 22906-0011. Tel.: 804-982-0825; Fax: 804-982-1616; E-mail: avs5u@elvis.med.virginia.edu.

© 1998 by the Biophysical Society

0006-3495/98/03/1579/12 \$2.00

al., 1995). We used this method to quantitate, with EPMA, $[Ca]_{mt}$ during nonlethal elevation of $[Ca^{2+}]_c$ in intact myocardium and so estimate the time-averaged rate of mitochondrial Ca^{2+} uptake. Our findings indicate that the ratio of total to free mitochondrial calcium is sufficiently high to allow the assessment of $[Ca^{2+}]_m$ from EPMA measurements of $[Ca]_{mt}$ and are consistent with the conclusion that significant mitochondrial uptake of calcium occurs only in the presence of prolonged, unphysiological elevations of $[Ca^{2+}]_c$. The implications of these findings about the role of $[Ca^{2+}]$ in mitochondrial metabolism are discussed.

METHODS

Rats (Sprague-Dawley strain, 350–400 g, male) were killed with an overdose of halothane as approved by the Animal Use Committee of the University of Virginia. Hearts were removed quickly and dissected in a protective Krebs-Ringer's solution (Mulieri et al., 1989) containing 30 mM 2,3-butanedione monoxime (BDM) and bubbled with 95% O_2 + 5% CO_2 at 4°C. BDM was used to maintain the myocardium in the relaxed state and protect it from hypoxia and cutting injury during dissection. The effects of BDM have been shown to be completely reversible in terms of contractility, energy metabolism, Ca^{2+} , and ultrastructure (Mulieri et al., 1989; Nichols et al., 1990; Marijic et al., 1991; Siegmund et al., 1991). The composition of Krebs-Ringer's solution in millimolar was: NaCl, 125; $CaCl_2$, 1.2; KCl, 4.7; $MgSO_4$, 1.2; KH_2PO_4 , 1.2; $NaHCO_3$, 18.7; and dextrose, 5.6, with a pH of 7.42. Papillary muscles or trabeculae 0.4–0.8 mm in diameter and 2–3 mm long were removed from the right ventricle

and mounted on a specially designed holder, and attached to an Akers AE801 force transducer. BDM was washed out by perfusion with Krebs-Ringer's solution bubbled with 95% O_2 + 5% CO_2 and maintained at 32°C. Muscles were stimulated with 4-ms pulses at 0.6 Hz. Twitch tension returned and stabilized in ~30 min. The paced perfused muscle was then allowed to equilibrate for 60 min.

The apparatus

Rapid freezing was carried out on a modified (inverted) CF100 cryofixation unit (Life Cell Corporation, Woodlands, TX) in which the sample is rapidly applied to a highly polished, liquid nitrogen-cooled diamond surface (Delaware Diamond Knives, Wilmington, DE) that is maintained under vacuum until the moment of freezing, when the vacuum is reversed with ultra-pure nitrogen gas. The small, specially designed muscle holder (Fig. 1) was attached by a magnetic base to the piston on the floor of the chamber of the cryofixation unit. A 7.5-mm Teflon ring was glued to the Delrin stage of the muscle holder to form a small 150 μ l muscle bath. A pedestal of 2.5% agar supported the muscle, raising its surface ~100 μ m above the Teflon ring for optimal contact with the cold diamond surface during cryofixation. The force transducer with a tungsten extension wire was mounted vertically and a small tungsten hook used to attach the muscle was easily mounted with shellac at right angles to the force transducer. The brittle shellac breaks away from the transducer if the hook is accidentally knocked, conserving the transducer. A cap prevented large lateral excursions of the transducer, which greatly reduced the frequency of transducer breakage during the freezing steps and retrieval of frozen tissue. One end of the muscle was attached with silk thread to the transducer hook and the other end to a permanently mounted hook at the opposite end of the holder. The vertical posts housing the tension transducer and the permanent hook were anchored to the main stage of the holder with spring-loaded screws

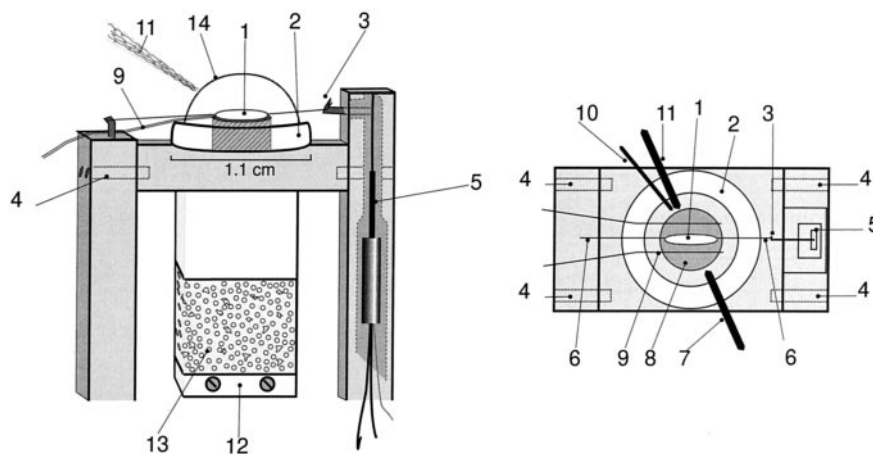

FIGURE 1 Muscle holder for cryo-fixation. The muscle holder was designed to fit the life cell cryo-fixation unit in order to freeze small 2–3 mm long papillary or trabecular muscles from the rat heart. When the holder is pressed against the cold block, the side wall containing the transducer clears the liquid nitrogen-cooled block. The holder, shown from a side and top view, allows perfusion of the muscle with oxygenated Krebs solution, temperature control (32°C), force measurements and electrical stimulation. The platform under the bubble and the side containing the transducer are made from black Delrin, while the side containing the stable muscle hook is made from stainless steel. Shown are the following: (1) muscle; (2) 1.1 cm Teflon ring, which makes contact with the cold diamond surface during freezing; (3) transducer hook; (4) two adjustable spring-loaded screws on each end of the holder for adjustment of the muscle length; (5) Akers force transducer. A channel was made in the top of the side wall housing the transducer (indicated by the rectangle surrounding #5 in the top view of the holder). The tungsten wire attached to the transducer chip extends to the top of this opening, which limits the excursion of the muscle hook, thus protecting the transducer against breakage. (6) Monofilament silk thread for attachment of the muscle to the hooks; (7) 1-mm polyethylene tubing connected to the perfusion pump for withdrawal of the perfusing solution; (8) muscle platform made from 2.5% agar which projects 100 μ m above the level of the Teflon ring (2), assuring good contact of the muscle with the cryo block. (9) Platinum (0.03 in diameter) stimulating electrodes placed on either side of the muscle. (10) Thermocouple connected to a temperature-controlling device; (11) polyethylene solution inlet for perfusion with oxygenated Krebs bicarbonate solution at 0.3 ml/min; (12) magnetic base for attachment to the plunger on the freezing apparatus; (13) sponge for compression and damping when the muscle holder is fired up to the liquid nitrogen-cooled block; (14) 150- μ l bubble of oxygenated Krebs bicarbonate solution covering the muscle.

and the screws were adjusted at either or both ends in order to stretch the muscle to the desired length. Oxygenated Krebs solution was infused and withdrawn at a rate of 0.3 ml/min via a peristaltic pump (Wiz, ISCO, Inc., Lincoln, NE). Constant temperature was maintained by wrapping the inlet tubing with heater tape and the temperature of the solution bubble was controlled at 32°C with a fine-wire thermocouple and a feedback controller (Omega CN76000, Omega Energy, Inc., Stamford, CT). Two Teflon-coated platinum wires, 0.03 in, were threaded through holes in the Teflon ring, mounted on either side parallel to the muscle bundle, and attached to a Grass SD9 stimulator (Astro-Med Inc., Warwick, RI). The mounting and manipulation of the muscle and the solutions were greatly aided by viewing the specimen on a TV screen via a small CCD camera assembled in the laboratory.

Experimental protocol

In order to achieve pseudo-steady-state levels of $[Ca^{2+}]_i$ in intact rat myocardium, tetani were produced by stimulating the muscle in the presence of ryanodine using the following protocols developed by Backx et al. (1995), who measured cytoplasmic $[Ca^{2+}]_i$ with fura-2.

1. *Resting group.* Following equilibration, muscles were perfused with Krebs-Ringer's solution gassed with 95% O₂ + 5% CO₂ at 30–32°C and paced at 0.6 Hz with 4.0-ms duration pulses. During the last 5 min of perfusion, 4% polyvinylpyrrolidone (PVP) was added to the perfusate as a cryoprotectant. This had no effect on the tension transients. The solution was quickly drained from the bubble while pacing at 0.6 Hz was continued, and the muscle was frozen during diastole by activating the solenoid that drives the shaft and the specimen, rapidly bringing the muscle in contact with the frost-free diamond surface precooled to 103 K. The specimen and holder were retrieved into liquid nitrogen, where the threads attaching the muscle to the hooks were cut and the specimen and agar pedestal were cleaved from the specimen holder.
2. *Tetanus group.* Following equilibration, muscles were paced at 0.6 Hz and perfused with 1.2 mM Ca²⁺-containing Krebs-Ringer's solution oxygenated with 95% O₂ + 5% CO₂ for 30 min as described above, but with the addition of 1 μM ryanodine. PVP (4%) was added to the perfusate during the last 5 min, followed by rapid removal of the solution. The muscle was tetanized by 40-ms duration pulses at 10 Hz. When tension had reached a plateau at 6.9 s ± 0.6 SE, the muscle was frozen as described above for the control group.
3. *Tetanus in the presence of high calcium group.* The same protocol as for group 2 was followed, with the exception that before tetanus stimulation 10 mM Ca²⁺ was added to the 4% PVP solution during tetanus.
4. *Resting high calcium group.* Muscles were treated identically to group 3, but instead of being tetanized, they continued to be paced at 0.6 Hz until freezing during diastole.

Frozen muscles were stored under liquid nitrogen before cryoultramicrotomy.

Cryoultramicrotomy and electron probe microanalysis

Frozen muscles were sectioned at 115 K in a Reichert Ultracut S with an FCS cryokit (Leica, Wien, Austria). The specimen was mounted on the microtome chuck with a mixture of ethanol and 2-propanol (1:3), which served as a cryoglue (Richter, 1994). The block was trimmed to ~0.15 × 0.1 mm with a trimming tool or glass knives, and sections were cut with a diamond knife (6° clearance; 35°C; Cryo-dry, Diatome, Fort Washington, PA). During sectioning, an antistatic device (Hauf Static Line, Diatome, Fort Washington, PA) was positioned so that the ionizing tip was within 1.5–3.0 cm of the knife edge. Sections were obtained with section thickness set at 70–80 nm from the outer, well-frozen few microns of the muscle bundle and the sections were transferred to 10-nm-thick carbon film

supported on 200-mesh copper grids and freeze-dried at 2×10^{-6} torr overnight. Following freeze-drying, grids were lightly carbon-coated for stabilization.

EPMA was carried out on a Philips CM12 electron microscope operated in the transmission mode and fitted with a LaB₆ filament and an energy-dispersive x-ray detector with XP3 pulse processor (Oxford Link, 6412, High Wycombe, UK) and 4 pi Spectral Engine I, using a program (DTSA) from the National Institute of Standards and Technology, Gaithersburg, MD (for acquisition and display). For quantitation, our own routines written in Lisp for XLisp-Stat (Tierney, 1990) were used. Spectra were analyzed by a minimum least-squares fitting routine, as published previously (Shuman et al., 1976; Kitazawa et al., 1983). The quantitation of elements in ultrathin cryosections is based on the relationship of the characteristic/continuum x-ray ratio (Hall, 1971). Specimens were viewed and analyzed at 173 K in a liquid nitrogen-cooled holder (613-P1, Gatan, Inc., Pittsburgh, PA). A total of 10 cells from 5 animals with 2 cells per muscle were analyzed for each experimental group. Within each cell, the beam was focused over three areas of 2 μm diameter excluding nuclei selected to represent whole-cell composition, three areas of 0.2 μm diameter over the A-band, excluding organelles, and three 0.2 μm diameter probes over mitochondria. The contribution of the carbon film to the mass (x-ray continuum) of each cryosection was evaluated by paired analysis of the C-film adjacent to the cryosection with the same electron dose as used for the whole-cell analysis, and the concentrations reported are corrected for the C-film contribution to the continuum. The greater mass thickness of mitochondria than cytoplasm (Somlyo et al., 1979; Buchanan et al., 1993; Ho et al., 1996) was included in the correction factors. Because the objective of the experiments required a sensitive measurement of changes in calcium concentrations, and the uncertainty of x-ray photon measurements follows Poisson statistics, spectra were collected until the standard deviation of an individual calcium concentration measurement was <1.2 mmol/kg dry weight.

Statistics

Data were analyzed using a general linear model analysis of variance for unbalanced ANOVA (SAS, 1989).

RESULTS

Contractile responses

The immediate transfer following removal of the excised hearts into oxygenated BDM-Krebs cryoprotective solution at 4°C maintained them in a relaxed state and allowed sufficient time for careful dissection. Normal twitch tension returned following the washout of BDM, as has been previously well documented (Mulieri et al., 1989; Marijic et al., 1991; Siegmund et al., 1991). Addition of 1.0 μM ryanodine to the perfusion solution produced an 80–90% reduction in twitch tension, which stabilized over 30 min (Figs. 2 and 3). This reflects the effect of ryanodine on the calcium release channel of the sarcoplasmic reticulum, because ryanodine does not alter the sensitivity of myofilaments to $[Ca^{2+}]_i$ (Fabiato, 1985). Stimulation of muscles in the presence of ryanodine at high frequency (10 Hz) for 7 s produced a maintained contracture consistent with pathological elevation of $[Ca^{2+}]_i$ (Figs. 2 and 3), as has been reported previously (Yue et al., 1986; Backx et al., 1995). Addition of 10 mM calcium to the perfusion solution transiently doubled the amplitude of twitch tension developed by the

FIGURE 2 Tension trace illustrating the protocol for inducing tetani in rat papillary or trabeculae muscles. The muscle is paced at 0.6 Hz before the tetanus with the time base changed periodically to show the individual twitches. The muscle was perfused for 30 min with 1 μM ryanodine, which depressed the magnitude of the twitch tension that subsequently increased upon the addition of 10 mM Ca_o . The solution surrounding the bubble was rapidly removed at the asterisk, which mechanically altered the tension recording, generally resulting in an increased twitch amplitude. A tetanus was induced with 10 Hz, 40 ms pulse duration stimulus. The muscle contacted the cryo block and froze at the indicated arrow.

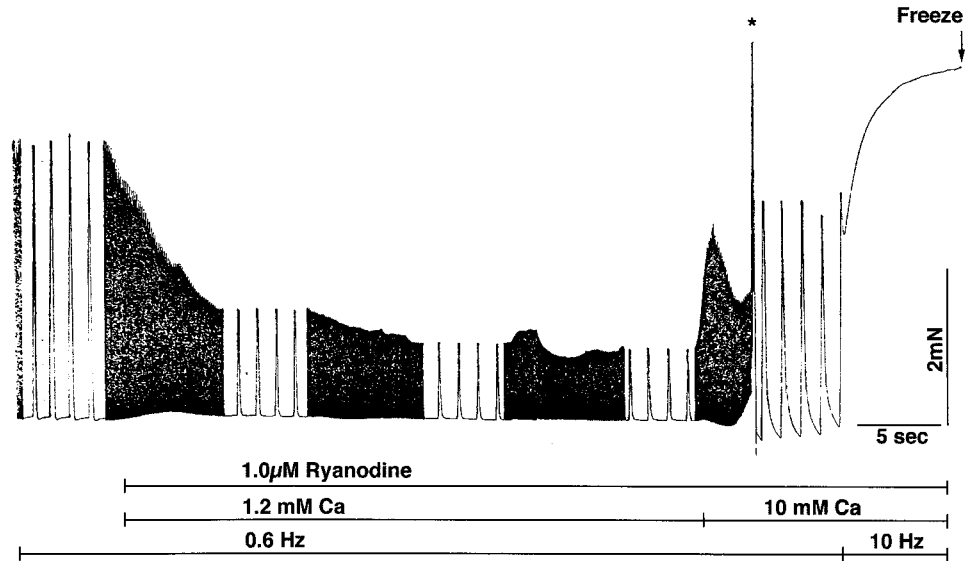

ryanodine-perfused muscle (Fig. 2). Occasionally diastolic tension rose after 2–3 s, as seen in Fig. 2. The increase in the recorded twitch amplitude at the time indicated by the asterisk was due to a mechanical effect of removal of the solution. Based on $[\text{Ca}^{2+}]_i$ measurements with fura-2 in rat trabeculae with the use of identical protocols to induce tetanus, free pseudo-steady-state $[\text{Ca}^{2+}]_i$ is $\sim 300\text{--}400$ nM in the presence of 1.2 mM $[\text{Ca}^{2+}]_o$ and $\sim 1\text{--}4$ μM in the presence of 10 mM $[\text{Ca}^{2+}]_o$ (Backx et al., 1995).

Cryosection structure and characteristics

A typical freeze-dried cryosection of a ryanodine-treated, tetanized muscle is shown in Fig. 4. A portion of two myocytes with intervening extracellular space, as well as an intercalated disk (arrows), sarcomeres, mitochondria, and transverse tubules are well resolved. Ice-crystal damage is seen surrounding the mitochondrial matrix, reflecting the high water content of the outer mitochondrial space between

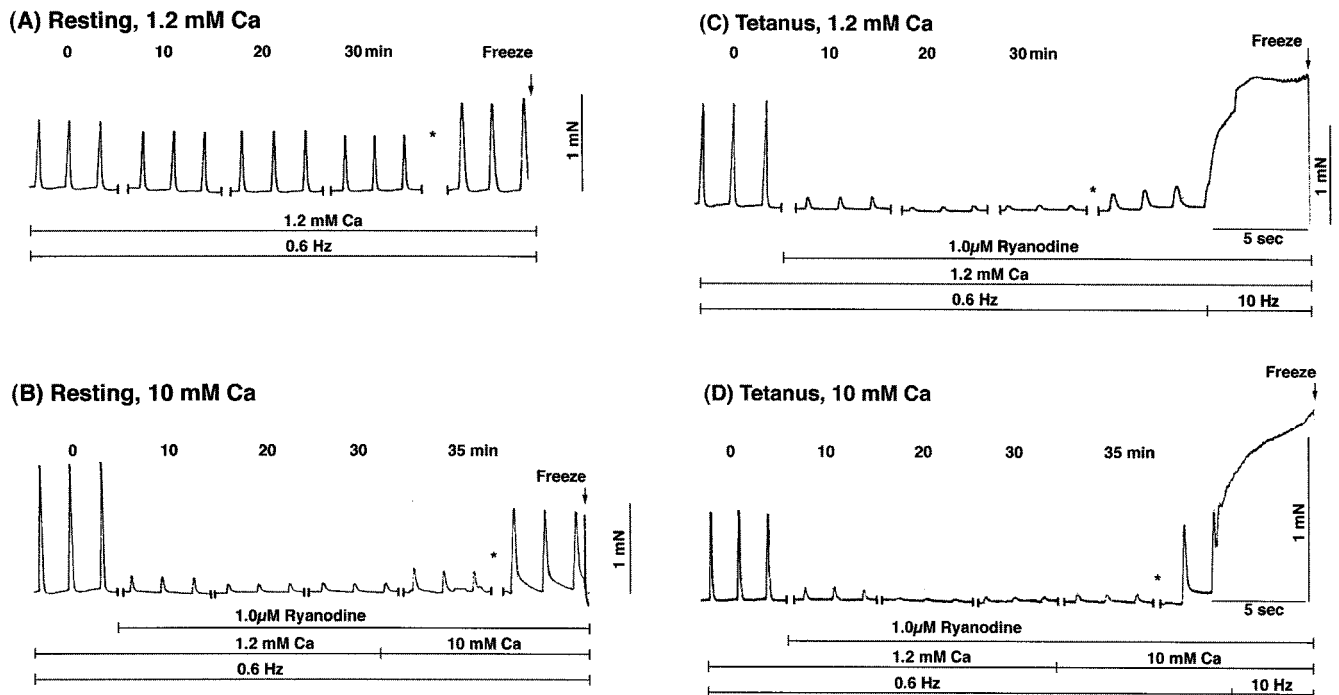

FIGURE 3 Force records showing the paired protocols for resting and tetani at 1.2 and 10 mM external calcium. The solution surrounding the muscle was rapidly withdrawn at the asterisk, 2–3 twitches were recorded and, in the case of tetanus, the stimulus was increased to 10 Hz, 40 ms duration pulses.

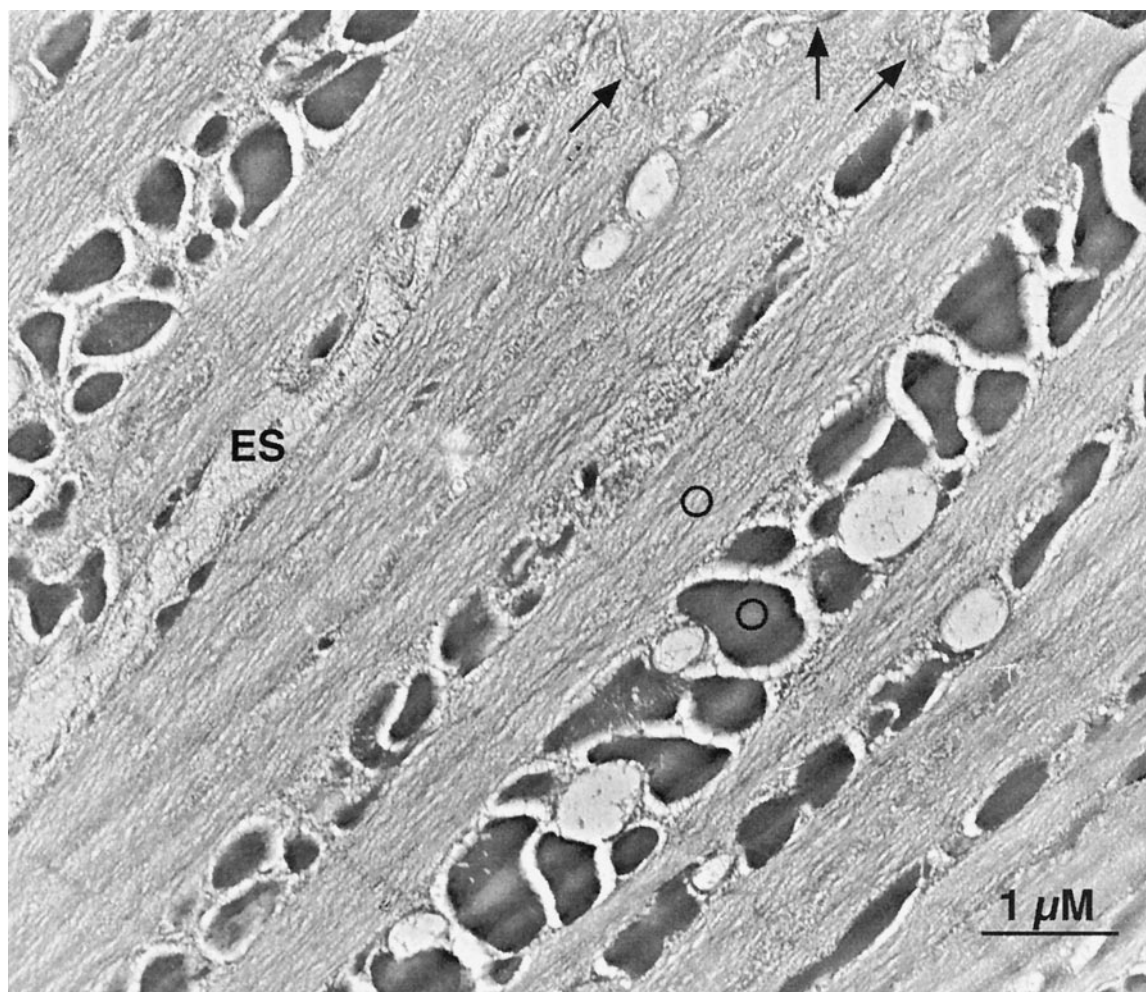

FIGURE 4 Electron micrograph of a longitudinal cryosection of a tetanized rat papillary muscle. The extracellular space (ES) and plasma membranes of the adjacent cells are well resolved, as are the Z-lines and mitochondria. An intercalated disk is indicated by the arrows. The small circles indicate the approximate size of the probes used for analysis of mitochondria and the A-band.

the inner and outer mitochondrial membranes; these spaces disappear as sections approach the more rapidly frozen surface of the muscle, which makes contact with the liquid nitrogen-cooled diamond surface. There was no obvious difference in the morphology of control or tetanized muscles exposed to either 1.2 or 10 mM $[Ca^{2+}]_o$.

Elemental composition of cell, A-band, and mitochondria

The concentration of elements in the freeze-dried cryosections is expressed as mmol/kg dry weight and reflects the total concentration (bound and free) of a given element in the microvolume irradiated by the electron beam (Shuman et al., 1976).

The cellular concentrations of sodium, magnesium, phosphorus, sulfur, chlorine, potassium, and calcium measured with 2 μ M diameter probes are shown in Fig. 5 and Table 1. Analysis of variance showed that the variance between treatment groups for all elements, except sodium and cal-

cium, reflected biological, rat-to-rat variability. There was a moderate increase in sodium in both tetanized groups and a highly significant ($P < 0.003$) increase in cell calcium in tetanized muscles perfused with 10 mM $[Ca^{2+}]_o$. This large increase in cellular calcium probably reflects the accumulation of calcium in the sarcoplasmic reticulum and results from locking of Ca^{2+} channels by ryanodine in the presence of uninhibited Ca-pump activity (Sutko and Kenyon, 1983; Jones, 1986).

The elemental composition of the A-band is shown in Fig. 6 and Table 1. The calcium concentration in the A-band was not significantly different in the control or tetanized muscles in the presence of either 1.2 mM or 10 mM $[Ca]_o$. Sodium was borderline ($P = 0.04$) higher in both tetanized groups, paralleling the results obtained with larger diameter probes.

The values of $[Ca]_{mt}$ are shown in Table 1. Mean diastolic $[Ca]_{mt}$ in the control cells was 0.5 ± 0.34 SE mmol/kg dry weight, essentially the same as the 0.5 ± 0.39 SE mmol/kg dry weight measured in mitochondria following a

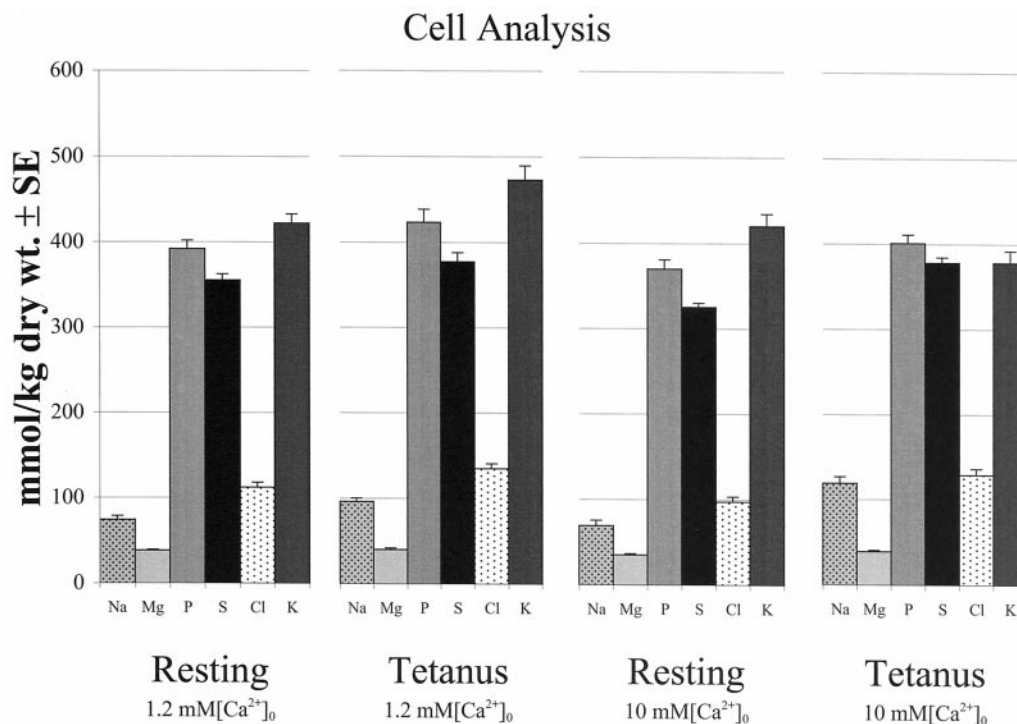

FIGURE 5 Elemental composition of cryosections of relaxed and tetanized muscles in 1.2 or 10 mM $[Ca^{2+}]_o$ determined with 2 μm diameter probes over regions of the cytoplasm excluding nuclei, but including mitochondria, sarcoplasmic reticulum, and myofilaments.

tetanus in the presence of 1.2 mM $[Ca^{2+}]_o$. There was a highly significant ($P = 0.002$) increase in $[Ca]_{mt}$ to 4.7 mmol/kg dry weight during the 7-s tetanus in the presence of 10 mM $[Ca^{2+}]_o$. The mitochondrial concentrations of other elements are shown in Fig. 7.

DISCUSSION

Our results show that the sensitivity of EPMA is sufficient for quantitating increases in $[Ca]_{mt}$ resulting from large, but nonlethal, elevations of cytosolic free calcium ($[Ca^{2+}]_c$) in the presence of cellular [ATP] and $[Ca^{2+}]_c$ sufficient to maintain tetanic force. We will compare these results with those of previous EPMA studies and with measurements obtained by independent methods, and evaluate the in situ rate of Ca^{2+} uptake by the mitochondrial uniporter and provide an estimate of the ratio of total ($[Ca]_{mt}$) to free ($[Ca^{2+}]_{mt}$) mitochondrial calcium.

The values of myocardial $[Ca]_{mt}$ in three species, quantitated by EPMA in several laboratories (Table 2), are, within the uncertainties of the measurements, nearly identical, averaging ~ 0.5 mmol/kg mitochondrial dry weight. Considering that 70–80% of dry weight is protein, this is equivalent to 0.6–0.7 nmol/mg mitochondrial protein. This value is, within experimental error, also the same as obtained with atomic absorption spectroscopy (0.33–0.95 nmol/mg protein) of mitochondria isolated under conditions designed to prevent calcium accumulation during cell fractionation (Lukács and Kapus, 1987) and further confirms the accuracy of EPMA in measuring calcium at high spatial resolution (Kitazawa et al., 1983). Thus, given the ~ 0.4 mmol/kg dry weight statistical uncertainty (95% confidence limit) of practically attainable EPMA measurements, the method can measure a change in $[Ca]_{mt}$ equivalent to ~ 0.5 –0.6 nmol/mg protein (see also Moravec et al., 1997). It is expected that electron energy loss spectroscopy (Shuman

TABLE 1 Intracellular calcium distribution in resting and tetanized cardiac muscle

Protocol	Total Calcium (mmol/kg dry wt \pm SE)		
	Cell	A-band	Mitochondria
Control (1.2 mM $[Ca^{2+}]_o$)	1.6 \pm 0.42	1.3 \pm 0.38	0.5 \pm 0.34
Tetanus (1.2 mM $[Ca^{2+}]_o$)	1.8 \pm 0.63	1.6 \pm 0.41	0.5 \pm 0.39
Control (10 mM $[Ca^{2+}]_o$)	2.6 \pm 0.44	2.1 \pm 0.49	1.2 \pm 0.35
Tetanus (10 mM $[Ca^{2+}]_o$)	5.9 \pm 0.73*	1.5 \pm 0.57	4.7 \pm 0.61 [#]

* $P < 0.003$.

[#] $P < 0.001$.

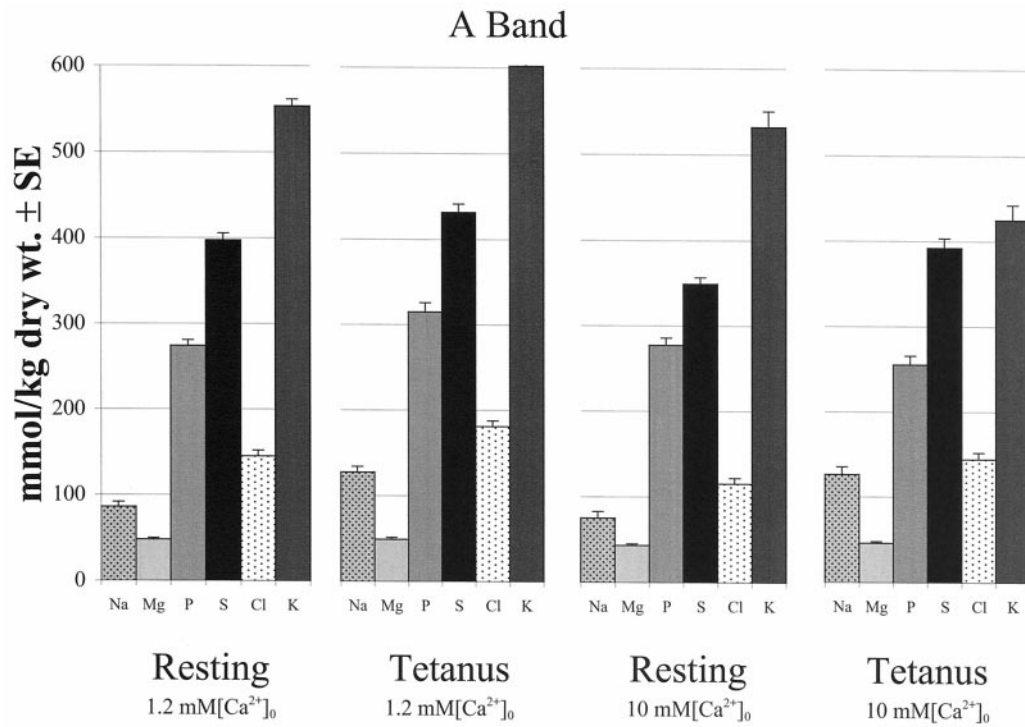

FIGURE 6 Elemental composition of the A-band of relaxed control and tetanized muscles at 1.2 or 10 mM [Ca²⁺]₀.

and Somlyo, 1987; Leapman et al., 1993) and/or the use of x-ray detectors having greater geometric detection efficiencies will increase the sensitivity of such measurements by approximately fourfold.

Diastolic [Ca²⁺]_m is 100 nM or less [Schreur et al. use for their calculation a kD of indo of 673 nM, whereas Miyata et al. use a value of 204 nM] in both whole rat hearts (Schreur et al., 1996) and isolated cardiac myocytes (Miyata et al.,

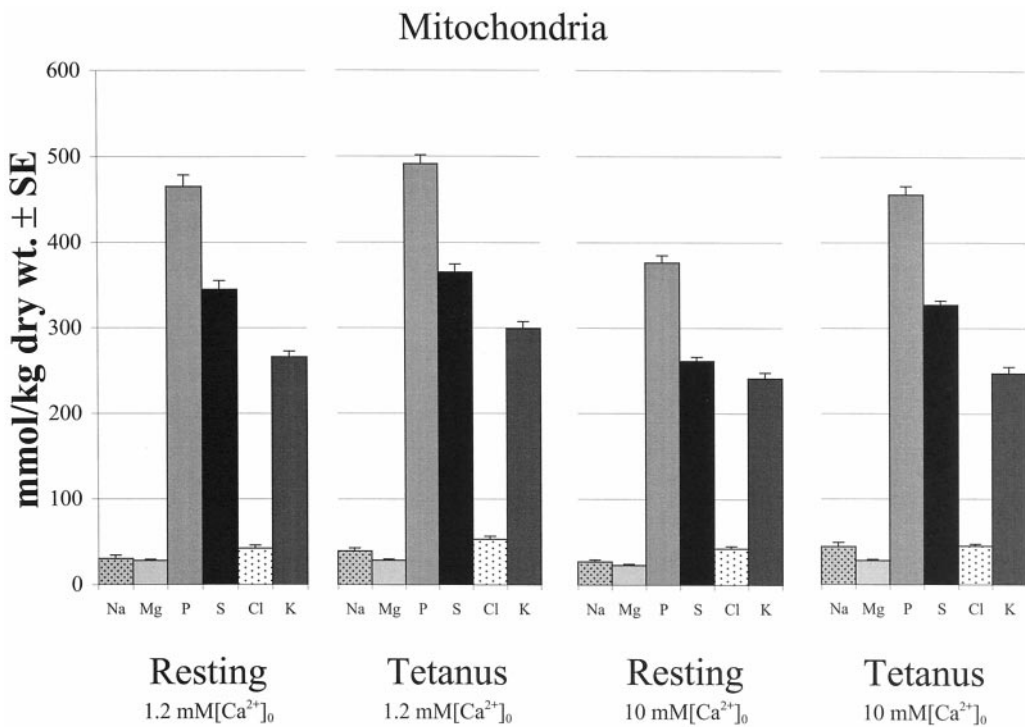

FIGURE 7 Elemental composition of mitochondria of relaxed and tetanized muscles in 1.2 or 10 mM [Ca²⁺]₀.

TABLE 2 Published values of total mitochondrial calcium measured by EPMA

Species	<i>T</i> (°C)	Rate (Hz)	[Ca] _o mM	[Ca] _{mt} mmol/kg dry wt ± SE		Reference
				Diastolic	Systolic	
Hamster papillary	28–29	0.6	1.9	0.6 ± 0.1	0.4 ± 0.1	Keller et al., 1995
Ferret papillary	37	1.2	2.0	0.4 ± 0.2		Miller and Tormey, 1995
Hamster papillary	28–29	0.2	1.9	0.1 ± 0.1	0.4 ± 0.2	Moravec and Bond, 1991
Hamster papillary	28–29	0.2	1.9		0.5 ± 0.1	Moravec and Bond, 1992
Hamster whole heart	37	5	1.8		1.0 ± 0.1	Moravec et al., 1997
Rat papillary	32	0.3	2.0	0.2 ± 0.2		Jorgensen et al., 1988
Rat ventricle	22–23	—			0.6 ± 0.2	Eckenhoff and Somlyo, 1989
Rat ventricular myocytes	21	—	1.0	0.4 ± 0.2		Miller and Tormey, 1993
Rat papillary	22–23	0.6	1.2	0.5 ± 0.3		Present study
Rat papillary	28–29	0.2	1.9	0.6 ± 0.2		Moravec et al., 1995
Rat atrium	32	—	1.2	0.3 ± 0.3		A.V. Somlyo et al., 1988

1991; DiLisa et al., 1993), but $[Ca^{2+}]_m$ can be raised with combined β -adrenergic and electrical stimulation at 4 Hz, over a period of ~ 60 s, to ~ 600 – 750 nM in single cardiac myocytes (Miyata et al., 1991; DiLisa et al., 1993; Griffiths et al., 1997) and to ~ 272 nM in whole hearts paced at 5 Hz in the presence of 6 mM $[Ca^{2+}]_o$ (Schreur et al., 1996). It is noteworthy that $[Ca^{2+}]_m$ responds only to time-averaged changes, but not to pulsatile (systolic) increases in $[Ca^{2+}]_c$ in either of these preparations (Miyata et al., 1991; Schreur et al., 1996) or in isolated cardiac mitochondria (Leisey et al., 1993), consistent with the behavior of $[Ca]_{mt}$ (Table 2). Unless assisted by β -adrenergic stimulus, even high-frequency electrical stimulation (4 Hz at 37°C) does not significantly increase $[Ca^{2+}]_m$ (DiLisa et al., 1993; Griffiths et al., 1997). Therefore, given that normal systolic $[Ca^{2+}]_c$ generally does not exceed 1 μ M (e.g., Miyata et al., 1991; Schreur et al., 1996), the micromolar $[Ca^{2+}]_c$ (4 μ M within 3 s, Fig. 2; Backx et al., 1995) to which mitochondria were exposed in the presence of 10 mM $[Ca^{2+}]_o$ during the ~ 7 -s tetanus (present study) probably represents a pathological maximum reached under nonlethal conditions.

Based on the 4.2 ± 0.1 mmol/kg dry mitochondrial weight increase in $[Ca]_m$ during 7-s tetanus (Table 1), we can estimate the in situ time-averaged mitochondrial transport by the mitochondrial uniporter to be ~ 0.8 nmol/mg mitochondrial protein s^{-1} , or slightly higher, considering that some egress also occurs. This rate is comparable to the 0.4 nmol/mg s^{-1} transported in the presence of 1 μ M Ca^{2+} by (liver) mitochondria at -180 mV (Gunter and Pfeiffer, 1990), in view of the >1 μ M $[Ca^{2+}]_i$ reached under our experimental conditions (Fig. 2 and Backx et al., 1995). Early studies (Scarpa and Graziotti, 1973) yielded values of Ca^{2+} uptake by isolated rat cardiac mitochondria exposed to 5 μ M Ca^{2+} in the range of 0.05–0.13 nmol/mg s^{-1} , probably representing some inhibition by 5 mM free Mg^{2+} in the solutions used. Therefore, the rate of mitochondrial calcium uptake measured in intact tissues by EPMA (present study; Broderick and Somlyo, 1987) is also consistent with independent measurements of the rate of transport by the mitochondrial uniporter.

EPMA measures $[Ca]_{mt}$, the sum of free and (mostly) bound calcium, whereas the quantity relevant for regulation

of mitochondrial dehydrogenases is $[Ca^{2+}]_m$ available for binding to the Ca^{2+} and Mg^{2+} -regulated enzymes such as pyruvate dehydrogenase phosphatase (Hansford and Castro, 1982; McCormack et al., 1992; reviewed in Gunter et al., 1994). Therefore, whether changes in $[Ca^{2+}]_m$ can be reliably assessed by EPMA depends on the ratio of total-to-free mitochondrial calcium, $[Ca]_{mt}/[Ca^{2+}]_m$, and the relationship between these two quantities. Based on $[Ca]_{mt}$ of 0.5 mmol/kg dry weight (present study) and reported values of diastolic $[Ca^{2+}]_m$ of 100 nM (see above), the ratio of $[Ca]_{mt}/[Ca^{2+}]_m$ is ~ 6700 (normalized to mitochondrial proteins as 75% of dry weight). Similar calculations, based on 6.2 nmol Ca/mg mitochondrial protein accumulated following a 7-s tetanus in the presence of 10 mM $[Ca^{2+}]_o$ and assuming $[Ca^{2+}]_m$ to reach ~ 1 μ M, yields a similar ratio of 6200. These values are significantly higher than the 1000:1 reported on the basis of studies of null point titration of isolated mitochondria (Hansford and Castro, 1982) [although Fig. 6 in the reference cited in Hansford and Castro (1982) suggests a ratio of 2500:1], but comparable to more recent estimates of 4500–7500:1 in rat heart (Lukács and Kapus, 1987), ~ 4000 in rat adrenal chromaffin cells (Babcock et al., 1997) and ~ 3600 in rat liver mitochondria (Gunter et al., 1988; but $>10,000$ in Saavedra-Molina et al., 1990). It is likely that the ratio is lower in the presence of larger increases in mitochondrial calcium that could saturate the available high-affinity matrix Ca-buffers (see below).

We can now evaluate whether EPMA measurements of $[Ca]_{mt}$ can provide valid information about the role of $[Ca^{2+}]_m$ in regulating the activity of mitochondrial dehydrogenases. We consider the $[Ca^{2+}]_m$ required for activating mitochondrial dehydrogenases and estimate its value on the basis of in situ EPMA measurements of $[Ca]_{mt}$ and the ratio (~ 6000 :1) of total/free mitochondrial calcium indicated above. Considering that half-maximal activation of oxoglutarate dehydrogenase occurs at 0.8 μ M $[Ca^{2+}]_m$ (Lukács et al., 1988), for a total/free ratio of 6000:1, we arrive at 4.8 mmol/kg dry mitochondrial weight as the $[Ca]_{mt}$ required for half-maximal activation of the enzyme; this value is in remarkably good agreement with the 3.3 mmol/kg dry weight (4.35 nmol/kg mitochondrial protein) measured in fura-2-loaded mitochondria (Lukács et al.,

1988). Somewhat lower values are obtained by using the $K_{0.5}$ of pyruvate dehydrogenase: 0.3 to 0.6 $\mu\text{M Ca}^{2+}$ (McCormack et al., 1992). In any case, the uncertainty of calibrating fluorescent reporters to measure $[\text{Ca}^{2+}]_m$ is considerably greater than the uncertainty of EPMA, because the behavior of fluorophores is dependent on local environment (e.g., pH, magnesium, ionic strength, etc.), whereas EPMA measures the results of atomic core shell ionizations (x-ray emissions) that are unaffected by such environmental influences. Since a 200 nM increase in $[\text{Ca}^{2+}]_m$ would result in a 1.2 mmol/kg increase in $[\text{Ca}]_{mt}$, within the sensitivity of EPMA, we conclude that EPMA is sufficiently sensitive for quantitating the $[\text{Ca}^{2+}]_m$ required for significant activation of the mitochondrial enzymes.

Considerable evidence obtained by independent methods also indicates that an increase in $[\text{Ca}^{2+}]_m$ is not a necessary condition for activating mitochondrial dehydrogenases. Thus, pyruvate dehydrogenase activity increases in the absence of a detectable increase in $[\text{Ca}]_{mt}$ during both inotropically potentiated systole (Moravec and Bond, 1992) and under increased workload induced by β -adrenergic stimulation or increasing perfusion pressure (Moravec et al., 1997). In neither of these studies did $[\text{Ca}]_{mt}$ reach values expected to significantly activate the mitochondrial dehydrogenases (Table 2). Furthermore, mitochondrial metabolism can be increased without the associated increase in NADH levels expected to result from activation of mitochondrial dehydrogenases (Wan et al., 1993; White and Wittenberg, 1995; Brandes and Bers, 1997). There is also evidence of other, non- $[\text{Ca}^{2+}]_m$ -mediated mechanisms of mitochondrial regulation, such as $[\text{Mg}^{2+}]_m$ (Somlyo et al., 1987; Bond et al., 1987; Panov and Scarpa, 1996) and by second- or higher-order effects of $[\text{ADP}]$ (Jenerson et al., 1996). Although EPMA measurements do show that $[\text{Ca}]_{mt}$ can be increased in contracting myocardium to the levels compatible with $[\text{Ca}^{2+}]_m$ regulating mitochondrial dehydrogenases (Moravec and Bond, 1992; present study), such increases appear to occur only during extremely unphysiological elevations of $[\text{Ca}^{2+}]_c$, such as induced by reducing $[\text{Na}^+]$ or tetanizing the heart.

We would be remiss to overlook the technically demanding and oft-cited studies of Wendt-Gallitelli and Isenberg (1991; Isenberg et al., 1993), who measured with EPMA a transient, very rapid (within a 15-ms period during systole) increase in $[\text{Ca}]_{mt}$ from 1.3 ± 0.2 to 3.7 ± 0.5 mmol/kg mitochondrial dry weight. Their results were obtained in isolated, patch-clamped guinea pig ventricular myocytes stimulated with a paired-pulse protocol designed to maximize Ca^{2+} influx, and may have been subject to transient leakage around the patch pipette during contraction. Moderate calcium loading of cells may also occur during the isolation of myocytes in the presence of 250 $\mu\text{M Ca}^{2+}$ (Wendt-Gallitelli and Isenberg, 1991), when gap junctions become sufficiently permeable to permit the entry of indo-1 into the isolated cells (Miyata et al., 1991), or reflect species-specific differences, in view of the greater contribution

of Ca^{2+} -entry to the Ca^{2+} transient in guinea pig than rat ventricular myocytes (Terracciano and MacLeod, 1997). The systolic rate of maximal Ca^{2+} influx into mitochondria calculated by Wendt-Gallitelli and Isenberg (1991; Isenberg et al., 1993), $4.3 \mu\text{mol min}^{-1} (\text{mg protein})^{-1}$ could not be and was not sustained, as also indicated by their report of diastolic values, without massive mitochondrial calcium loading and rapid ossification of the heart.

Our present results are consistent with the earliest EPMA studies indicating that in cardiac myocytes (Somlyo et al., 1975; Moravec and Bond, 1992), as in smooth (Somlyo et al., 1979, 1982; Broderick and Somlyo, 1987) and skeletal (Gonzalez-Serratos et al., 1978; Somlyo et al., 1981; Yoshioka and Somlyo, 1984) muscle, significant mitochondrial Ca-loading occurs only during prolonged, abnormal elevations (1 μM or greater) of cytosolic $[\text{Ca}^{2+}]$. The conclusion, based on early EPMA studies (reviewed in Somlyo et al., 1987) and the low affinity of isolated cardiac mitochondria for Ca^{2+} (Scarpa and Graziotti, 1973; Kitazawa, 1976), that mitochondria do not play a significant role in physiological relaxation mechanisms, has been reinforced more recently by independent, albeit less direct, methods (Bassani et al., 1992; Balke et al., 1994). The low affinity of mitochondria for Ca^{2+} in non-muscle cells has also been confirmed by recent studies employing Ca^{2+} indicators (e.g., Friel and Tsien, 1994; Xu et al., 1997), and is consistent with the results of EPMA showing that significant increases in $[\text{Ca}]_{mt}$ occur only as the result of abnormal elevations in $[\text{Ca}^{2+}]_c$, such as produced by $[\text{Na}]_o$ reduction or by caffeine, an agent that not only raises $[\text{Ca}^{2+}]_c$ but eliminates the major physiological Ca-sink: the sarcoplasmic and endoplasmic reticulum. Indeed, caffeine-induced mitochondrial calcium uptake occurs even in frog skeletal muscle (Yoshioka and Somlyo, 1984), in which the SR is universally recognized as the only significant physiological store of intracellular calcium.

Finally, we need to consider how the various experimental uncertainties could affect our conclusions. First of all, as noted above, the ratio of total/free calcium may not be fixed, but variable. This, indeed, is probably the case in the presence of large, but still reversible, accumulations of mitochondrial calcium associated with phosphate uptake (Broderick and Somlyo, 1987) that, if unchecked, culminates in the deposition of intramitochondrial hydroxyapatite granules (Carafoli et al., 1995; Broderick and Somlyo, 1987). However, such nonlinear departure of the relationship between total and free calcium occurs at high, pathological levels of calcium loading (Fig. 4 in Lukács and Kapus, 1987) that are not encountered under normal physiological conditions. We are unaware of experimental evidence showing nonlinearity of this relationship at the low physiological levels of mitochondrial Ca^{2+} uptake. The uncertainty of matrix $[\text{Ca}^{2+}]_m$ measurements also bears strongly on conclusions about the total/free mitochondrial calcium ratio. Even allowing for uncertainties due to the sensitivity of Ca^{2+} indicators to the chemical environment noted above, it is reassuring that the published low (100–200 nM)

values of resting $[Ca^{2+}]_{mt}$ used for our estimate of the total/free ratio are uniformly in this range when obtained with a variety of fluorescent indicators and in several cell types. Furthermore, these measurements of resting matrix $[Ca^{2+}]_{mt}$ were based on calibrations obtained under the identical (resting) conditions and in the absence of other (e.g., pH, Mg^{2+} , etc.) environmental transients. Next, it can be questioned whether the total/free ratio, based on steady-state measurements, is the same as the ratio during a rapid transient, should such transients occur due to changes in either $[Ca^{2+}]_{mt}$ or in the matrix chemical environment. Clearly, if a sudden decrease in matrix Ca^{2+} buffering caused this ratio to fall to, say, 100:1, then the current state of the art sensitivity of EPMA would not permit one to detect a few hundred nM increase in $[Ca^{2+}]_{mt}$. However, to be physiologically relevant, such an unlikely change would require a rapid, selective, and nearly irreversible binding of Ca^{2+} to Ca^{2+} -sensitive mitochondrial enzymes rather than to the high concentration of available phosphates, phospholipids, etc. (Broderick and Somlyo, 1987; Babcock et al., 1997). We are not aware of published non-steady-state calibration of fluorescent or luminescent indicators and, until reassured by such calibrations, we consider it reasonable to rely on estimates based on steady-state values.

Our present and earlier results support the conclusion that mitochondria are major Ca^{2+} buffers protecting cells against pathological and potentially lethal Ca^{2+} loading. Given the above uncertainties of measurements, we do not exclude the possibility that during prolonged near-physiological elevations (if patch clamps are considered near-physiological), mitochondria take up modest amounts (e.g., 50 nM) of Ca^{2+} , but the physiological significance of such a change is questionable. We find no evidence against the conclusion (Carafoli et al., 1995; Somlyo et al., 1987) that in muscle the sarcoplasmic reticulum, and in nonmuscle cells the endoplasmic reticulum, provide the major physiological sources and sinks of cellular Ca.

We are indebted to Jackie Spencer for help with development and machining of the muscle cryo-holder, Frank Gibson of Life Cell Corporation for advice on modification of the freezing apparatus, Dr. Zhifeng Shao for suggestions and help with the homemade CCD camera, and Joseph Craft for help with cryosectioning. We greatly appreciate and acknowledge Steve Majewski for his expertise and contributions to the software development and programs for statistical analysis. We thank Jama Coartney for the drawing of Fig. 1 and preparation of the other figures, and Barbara Nordin for her expertise in preparation of the manuscript.

This work was supported by National Institutes of Health Grant HL-48807.

REFERENCES

- Babcock, D. F., J. Herrington, P. C. Goodwin, Y. B. Park, and B. Hille. 1997. Mitochondrial participation in the intracellular Ca^{2+} network. *J. Cell Biol.* 136:833–844.
- Backx, P. H., W.-D. Gao, M. D. Azan-Backx, and E. Marban. 1995. The relationship between contractile force and intracellular $[Ca^{2+}]$ in intact rat trabeculae. *J. Gen. Physiol.* 105:1–19.
- Balke, C. W., T. M. Egan, and W. G. Wier. 1994. Processes that remove calcium from the cytoplasm during excitation-contraction coupling in intact rat heart cells. *J. Physiol.* 474:447–462.
- Bassani, R. A., J. W. M. Bassani, and D. M. Bers. 1992. Mitochondrial and sarcolemmal Ca^{2+} -transport reduce $[Ca^{2+}]_i$ during caffeine contractures in rabbit cardiac myocytes. *J. Physiol.* 453:591–608.
- Blinks, J. R. 1992. Intracellular $[Ca^{2+}]$ measurements. In *The Heart and Cardiovascular System*, 2nd ed. H. A. Fozzard, E. Haber, R. B. Jennings, A. M. Katz, and H. E. Morgan, editors. Raven Press, Ltd., New York. 1171–1201.
- Bond, M., G. Vadasz, A. V. Somlyo, and A. P. Somlyo. 1987. Subcellular calcium or magnesium mobilization in rat liver stimulated in vivo with vasopressin and glucagon. *J. Biol. Chem.* 262:15630–15636.
- Brandes, R., and D. M. Bers. 1997. Intracellular Ca^{2+} increases the mitochondrial NADH concentration during elevated work in intact cardiac muscle. *Circ. Res.* 80:82–87.
- Broderick, R., and A. P. Somlyo. 1987. Calcium and magnesium transport in situ mitochondria: electron probe analysis of vascular muscle. *Circ. Res.* 61:523–530.
- Buchanan, R. A., R. D. Leapman, M. F. O'Connell, T. S. Reese, and S. B. Andrews. 1993. Quantitative scanning transmission electron microscopy of ultrathin cryosections: subcellular organelles in rapidly frozen liver and cerebellar cortex. *J. Struct. Biol.* 110:244–255.
- Busselen, P. 1985. Suppression of cellular injury during the calcium paradox in rat heart by factors which reduce calcium uptake by mitochondria. *Pflügers Arch.* 404:166–171.
- Carafoli, E., M. Chiesi, and P. Gazzotti. 1995. Membrane carriers related to intracellular calcium regulation. In *Hypertension: Pathophysiology, Diagnosis, and Management*, 2nd ed. J. H. Laragh and B. M. Brenner, editors. Raven Press Ltd., New York. 1245–1259.
- DiLisa, F., G. Gambassi, H. Spurgeon, and R. G. Hansford. 1993. Intramitochondrial free calcium in cardiac myocytes in relation to dehydrogenase activation. *Cardiovasc. Res.* 27:1840–1844.
- Eckenhoff, R. G., and A. P. Somlyo. 1989. Cardiac mitochondrial calcium content during fatal doxorubicin toxicity. *Toxicol. Appl. Pharmacol.* 97:167–172.
- Fabiato, A. 1985. Effects of ryanodine in skinned cardiac cells. *Fed. Proc.* 44:2970–2976.
- Friel, D. D., and R. W. Tsien. 1994. An FCCP-sensitive Ca^{2+} store in bullfrog sympathetic neurons and its participation in stimulus-evoked changes in $[Ca^{2+}]_i$. *J. Neurosci.* 14:4007–4024.
- Gonzalez-Serratos, H., A. V. Somlyo, G. McClellan, H. Shuman, L. M. Borrero, and A. P. Somlyo. 1978. Composition of vacuoles and sarcoplasmic reticulum in fatigued muscle: electron probe analysis. *Proc. Natl. Acad. Sci. U.S.A.* 75:1329–1333.
- Griffiths, E. J., S.-K. Wei, M. C. P. Haigney, C. J. Ocampo, M. D. Stern, and H. S. Silverman. 1997. Inhibition of mitochondrial calcium efflux by clonazepam in intact single rat cardiomyocytes and effects on NADH production. *Cell Calcium.* 21:321–329.
- Gryniewicz, G., M. Poenie, and R. Y. Tsien. 1985. A new generation of Ca^{2+} indicators with greatly improved fluorescence properties. *J. Biol. Chem.* 260:3440–3450.
- Gunter, T. E., K. E. Gunter, S.-S. Sheu, and C. E. Gavin. 1994. Mitochondrial calcium transport: physiological and pathological relevance. *Am. J. Physiol.* 267:C313–C339.
- Gunter, T. E., and D. R. Pfeiffer. 1990. Mechanisms by which mitochondria transport calcium. *Am. J. Physiol.* C755–C786.
- Gunter, T. E., D. Retrepo, and K. K. Gunter. 1988. Conversion of esterified fura-2 and indo-1 to Ca^{2+} -sensitive forms by mitochondria. *Am. J. Physiol.* C304–C310.
- Hall, T. A. 1971. The microprobe assay of chemical elements. In *Physical Techniques in Biological Research*, 1A, Second Edition. G. Oster, editor. Academic Press, New York. 157–275.
- Hansford, R. G., and F. Castro. 1982. Intramitochondrial and extramitochondrial free calcium ion concentrations of suspensions of heart mitochondria with very low, plausibly physiological, contents of total calcium. *J. Bioenerg. Biomembr.* 14:361–376.
- Ho, R., Z. Shao, and A. P. Somlyo. 1996. The effects of nonuniform specimen thickness on thickness determination and elemental quantitation with electron energy loss spectroscopy (EELS). *J. Microscopy Soc. Am.* 2:87–97.
- Isenberg, G., S. Han, A. Schiefer, and M.-F. Wendt-Gallitelli. 1993. Changes in mitochondrial calcium concentration during the cardiac contraction cycle. *Cardiovasc. Res.* 27:1800–1809.

- Jeneson, J. A. L., R. W. Wiseman, H. V. Westerhoff, and M. J. Kushmerick. 1996. The signal transduction function for oxidative phosphorylation is at least second order in ADP. *J. Biol. Chem.* 271:27995–27998.
- Jones, L. R. (1986) *In* The Heart and Cardiovascular System: Scientific Foundations, Vol. 1. H. A. Fozzard, R. B. Jennings, E. Haber, A. M. Katz, and H. E. Morgan, eds. Raven Press. 253–261.
- Jorgensen, A. O., R. Broderick, A. P. Somlyo, and A. V. Somlyo. 1988. Two structurally distinct calcium storage sites in rat cardiac sarcoplasmic reticulum: an electron microprobe analysis study. *Circ. Res.* 63: 1060–1069.
- Keller, E., C. S. Moravec, and M. Bond. 1995. Altered subcellular Ca^{2+} regulation in papillary muscles from cardiomyopathic hamster hearts. *Am. J. Physiol.* 37:H1875–H1883.
- Kitazawa, T. 1976. Physiological significance of calcium uptake by mitochondria in the heart in comparison with that by cardiac sarcoplasmic reticulum. *J. Biochem.* 80:1129–1147.
- Kitazawa, T., H. Shuman, and A. P. Somlyo. 1983. Quantitative electron probe analysis: problems and solutions. *Ultramicroscopy.* 11:251–262.
- Leapman, R. D., J. A. Hunt, R. A. Buchanan, and S. B. Andrews. 1993. Measurements of low calcium concentrations in cryosectioned cells by parallel-EELS mapping. *Ultramicroscopy.* 49:225–234.
- LeFurgey, A., M. Bond, and P. Ingram. 1988. Frontiers in electron probe microanalysis: application to cell physiology. *Ultramicroscopy.* 24: 185–220.
- Leisey, J. R., L. W. Grotyohann, D. A. Scott, and R. C. Scaduto, Jr. 1993. Regulation of cardiac mitochondrial calcium by average extramitochondrial calcium. *Am. J. Physiol.* 265:H1203–H1208.
- Lukács, G. L., and A. Kapus. 1987. Measurement of the matrix free Ca^{2+} concentration in heart mitochondria by entrapped fura-2 and quin2. *Biochem. J.* 248:609–613.
- Lukács, G. L., A. Kapus, and A. Fonyó. 1988. Parallel measurement of oxoglutarate dehydrogenase activity and matrix free Ca^{2+} in fura-2-loaded heart mitochondria. *FEBS Lett.* 229:219–223.
- Marijic, J., N. Buljubasic, D. F. Stowe, L. A. Turner, J. P. Kampine, and Z. T. Bosnjak. 1991. Opposing effects of diacetyl monoxime on contractility and calcium transients in isolated myocardium. *Am. J. Physiol.* 260:H1153–H1159.
- McCormack, J. G., R. L. Daniel, N. J. Osbaldeston, G. A. Rutter, and R. M. Denton. 1992. Mitochondrial Ca^{2+} transport and the role of matrix Ca^{2+} in mammalian tissues. *Biochem. Soc. Trans.* 20:153–159.
- McMillin-Wood, J., P. E. Wolkowicz, A. Chu, C. A. Tate, M. A. Goldstein, and M. L. Entman. 1980. Calcium uptake by two preparations of mitochondria from heart. *Biochim. Biophys. Acta.* 591:251–265.
- Miller, T. W., and J. McD. Tormey. 1995. Subcellular calcium pools of ischaemic and reperfused myocardium characterised by electron probe. *Cardiovasc. Res.* 2:85–94.
- Miyamae, M., S. A. Camacho, M. W. Weiner, and V. M. Figueredo. 1996. Attenuation of postischemic reperfusion injury is related to prevention of $[\text{Ca}]_m$ overload in rat hearts. *Am. J. Physiol.* H2145–H2153.
- Miyata, H., H. S. Silverman, S. J. Sollott, E. G. Lakatta, M. D. Stern, and R. G. Hansford. 1991. Measurement of mitochondrial free Ca^{2+} concentration in living single rat cardiac myocytes. *Am. J. Physiol.* 261: H1123–H1134.
- Moravec, C. S., and M. Bond. 1991. Calcium is released from the junctional sarcoplasmic reticulum during cardiac muscle contraction. *Am. J. Physiol.* 260:H989–H997.
- Moravec, C. S., and M. Bond. 1992. Effect of inotropic stimulation on mitochondrial calcium in cardiac muscle. *J. Biol. Chem.* 267: 5310–5316.
- Moravec, C. S., R. W. Desnoyer, M. Milovanovic, M. D. Schluchter, and M. Bond. 1997. Mitochondrial calcium content in isolated perfused heart: effects of inotropic stimulation. *Am. J. Physiol.* 273: H1432–H1439.
- Mulieri, L. A., G. Hasenfuss, F. Ittleman, E. M. Blanchard, and N. M. Alpert. 1989. Protection of human left ventricular myocardium from cutting injury with 2,3-butanedione monoxime. *Circ. Res.* 65: 1441–1444.
- Nichols, C. G., and W. J. Lederer. 1990. The role of ATP in energy deprivation contractures in unloaded rat ventricular myocytes. *Can. J. Physiol. Pharmacol.* 68:183–194.
- Panov, A., and A. Scarpa. 1996. Mg^{2+} control of respiration in isolated rat liver mitochondria. *Biochemistry.* 35:12849–12856.
- Pozzan, T., R. Rizzuto, P. Volpe, and J. Meldolesi. 1994. Molecular and cellular physiology of intracellular calcium stores. *Physiol. Rev.* 74: 595–636.
- Richter, K. 1994. A cryogluce to mount vitreous biological specimens for cryoultramicrotomy at 110 K. *J. Microsc.* 173:143–147.
- Rizzuto, R., C. Bastianutto, M. Brini, M. Murgia, and T. Pozzan. 1994. Mitochondrial Ca^{2+} homeostasis in intact cells. *J. Cell Biol.* 126: 1183–1194.
- Saavedra-Molina, A., S. Uribe, and T. M. Devlin. 1990. Control of mitochondrial matrix calcium: studies using fluo-3 as a fluorescent calcium indicator. *Biochem. Biophys. Res. Commun.* 167:148–153.
- SAS Institute Inc. 1989. SAS/STAT® User's Guide, Version 6, 4th ed, Vol. 2. SAS Institute Inc., Cary, NC.
- Scarpa, A., and P. Graziotti. 1973. Mechanisms for intracellular calcium regulation in heart. *J. Gen. Physiol.* 62:756–772.
- Schreur, J. H. M., V. M. Figueredo, M. Miyamae, D. M. Shames, A. J. Baker, and S. A. Camacho. 1996. Cytosolic and mitochondrial $[\text{Ca}^{2+}]$ in whole hearts using indo-1 acetoxymethyl ester: effects of high extracellular Ca^{2+} . *Biophys. J.* 70:2571–2580.
- Shuman, H., and A. P. Somlyo. 1987. Electron energy loss analysis of near-trace-element concentrations of calcium. *Ultramicroscopy.* 21: 23–32.
- Shuman, H., A. V. Somlyo, and A. P. Somlyo. 1976. Quantitative electron probe microanalysis of biological thin sections: methods and validity. *Ultramicroscopy.* 1:317–339.
- Siegmund, B., T. Kliez, P. Schwartz, and H. M. Piper. 1991. Temporary contractile blockade prevents hypercontracture in anoxic-reoxygenated cardiomyocytes. *Am. J. Physiol.* 260:H426–H435.
- Somlyo, A. P. 1985. Cell calcium measurement with electron probe and electron energy loss analysis. *Cell Calcium.* 6:197–212.
- Somlyo, A. V., H. Gonzalez-Serratos, H. Shuman, G. McClellan, and A. P. Somlyo. 1981. Calcium release and ionic changes in the sarcoplasmic reticulum of tetanized muscle: an electron-probe study. *J. Cell Biol.* 90:577–594.
- Somlyo, A. V., J. Silcox, and A. P. Somlyo. 1975. Electron probe analysis and cryoultramicrotomy of cardiac muscle: mitochondrial granules. *Proceedings EMSA, 33rd Annual Meeting*, Claitors Publishing Division, Baton Rouge, LA. 532–533.
- Somlyo, A. P., A. V. Somlyo, M. Bond, R. Broderick, Y. E. Goldman, H. Shuman, J. W. Walker, and D. R. Trentham. 1987. Calcium and magnesium movements in cells and the role of inositol trisphosphate in muscle. *In* Cell Calcium and the Control of Membrane Transport. D. C. Eaton and L. J. Mandel, editors. Rockefeller University Press, New York. 42:77–92.
- Somlyo, A. P., A. V. Somlyo, and H. Shuman. 1979. Electron probe analysis of vascular smooth muscle. *J. Cell Biol.* 81:316–335.
- Somlyo, A. P., A. V. Somlyo, H. Shuman, and M. Endo. 1982. Calcium and monovalent ions in smooth muscle. *Fed. Proc.* 41:2883–2890.
- Sutko, J. L., and J. L. Kenyon. 1983. Ryanodine modification of cardiac muscle responses to potassium-free solutions. Evidence for inhibition of sarcoplasmic reticulum calcium release. *J. Gen. Physiol.* 82:385–404.
- Terracciano, C. M. N., and K. T. MacLeod. 1997. Measurements of Ca^{2+} entry and sarcoplasmic reticulum Ca^{2+} content during the cardiac cycle in guinea pig and rat ventricular myocytes. *Biophys. J.* 72:1319–1326.
- Tierney, L. 1990. LISP-STAT: An object-oriented environment for statistical computing and dynamic graphics. John Wiley & Sons, New York.
- Wan, B., C. Doumen, J. Duszynski, G. Salama, T. C. Vary, and K. F. LaNoue. 1993. Effects of cardiac work on electrical potential gradient across mitochondrial membrane in perfused rat hearts. *Am. J. Physiol.* 265:H453–H460.
- Wendt-Gallitelli, M.-F., and G. Isenberg. 1991. Total and free myoplasmic calcium during a contraction cycle: x-ray microanalysis in guinea-pig ventricular myocytes. *J. Physiol.* 435:349–372.
- White, R. L., and B. A. Wittenberg. 1995. Effects of calcium on mitochondrial NAD(P)H in paced rat ventricular myocytes. *Biophys. J.* 69:2790–2799.

- Williford, D. J., V. K. Sharma, M. Korth, and S.-S. Sheu. 1990. Spatial heterogeneity of intracellular Ca^{2+} concentration in nonbeating guinea pig ventricular myocytes. *Circ. Res.* 66:234–241.
- Xu, T., M. Naraghi, H. Kang, and E. Neher. 1997. Kinetic studies of Ca^{2+} binding and Ca^{2+} clearance in the cytosol of adrenal chromaffin cells. *Biophys. J.* 73:532–545.
- Yoshioka, T., and A. P. Somlyo. 1984. Calcium and magnesium contents and volume of the terminal cisternae in caffeine-treated skeletal muscle. *J. Cell Biol.* 99:558–568.
- Yue, D. T., E. Marban, and W. G. Wier. 1986. Relationship between force and intracellular $[\text{Ca}^{2+}]$ in tetanized mammalian heart muscle. *J. Gen. Physiol.* 87:223–242.