

IMPEDANCE COMPONENTS IN LONGITUDINAL DIRECTION IN THE GUINEA-PIG TAENIA COLI

BY M. OHBA, Y. SAKAMOTO, H. TOKUNO
AND T. TOMITA

*From the Department of Physiology, School of Medicine,
Fukuoka University, Fukuoka 814, Japan*

(Received 30 April 1975)

SUMMARY

1. When the tissue impedance of the guinea-pig taenia coli was measured across a 2 mm sucrose gap in a longitudinal direction, the impedance locus could be fitted by two different circular arcs. Their characteristic frequencies were about 0.6 and 240 Hz after 60 min superfusion with sucrose solution. From the effects of changing the width of sucrose gap and of transection of tissue, and also from taking the difference between impedances measured at two distances, it was concluded that the low-frequency locus corresponds to the transverse impedance of the plasma membrane and the high-frequency locus to the longitudinal tissue impedance.

2. A change in the longitudinal tissue impedance was measured during superfusion with sucrose solution, using a frequency range between 5 Hz and 10 kHz. The admittance decreased with time of superfusion and this time course could be expressed by the sum of three exponential terms. The fastest component, having a time constant of 1.3 min at 10 kHz, was interpreted to correspond to a process of wash-out of extracellular medium.

3. Admittances at zero and infinite frequencies were obtained from the impedance locus. The decrease in these admittances with the time was analysed and the values at the start of washing were obtained by extrapolating the admittance change to zero time.

4. From these values it was estimated that the myoplasmic resistance was 214 Ω cm, the junctional resistance 372 Ω cm, and the junctional capacity 3.1 μ F/cm at 25° C. In these calculations the equivalent circuit of tissue was assumed to be expressed by two components in series: one for the myoplasmic resistance and the other for the junction which has the junctional resistance and capacity in parallel.

5. After 90 min superfusion with sucrose solution, the total tissue impedance measured at zero frequency was increased from 586 to 3034 Ω cm. In the total impedance the myoplasmic resistance was

increased from 214 to 914 Ω cm and the junctional resistance from 372 to 2120 Ω cm. Thus, the change in junctional resistance was greater than that in myoplasmic resistance during superfusion of sucrose solution.

INTRODUCTION

Many smooth muscle cells probably communicate with each other electrically through the nexus or tight junction (Dewey & Barr, 1962, 1964), which has a low electrical resistance. The cable properties of the tissue and propagation of action potentials would be correlated with the existence of the junction. In order to calculate the electrical characteristics of the surface membrane of muscle fibre from the cable properties, it is important to obtain an absolute value of the longitudinal tissue resistance, since this is composed of both myoplasmic resistance and the junctional resistance between muscle fibres (Abe & Tomita, 1968; Tomita, 1970).

It has been shown that the contribution of the junctional resistance to the longitudinal tissue impedance of the guinea-pig taenia coli is considerable and that the impedance is dependent on the frequencies of alternating current used for the measurement (Jones & Tomita, 1967; Tomita, 1969). However, in previous experiments there are some uncertainties about the shunting effect of extracellular solution. When the preparation is superfused with sucrose solution to remove the electrical shunt, the tissue impedance seems to be increased far beyond the physiological value. The aim of the present work was to analyse this further since the electrical properties of smooth muscles immersed in pure sucrose solution are important for better understanding of the sucrose-gap recording technique.

We have therefore investigated the time course of changes in the tissue impedance during superfusion with sucrose solution, and the results obtained were used to estimate the absolute value of the longitudinal impedance of the guinea-pig taenia coli.

METHODS

Guinea-pigs weighing 300–400 g were stunned and bled, and pieces of the taenia coli (uniform diameter of about 0.5 mm and length 30 mm) were dissected. A diagram of the arrangements for measuring the longitudinal impedance of the tissue is shown in Fig. 1. In the qualitative experiments a possible contribution of the impedance of the plasma membrane at both ends of the preparation to the total tissue impedance was investigated. The preparation was set up in a three compartment chamber (Fig. 1A) and the centre compartment, which was separated by a rubber membrane from the side compartments containing Krebs solution, was perfused with isosmotic sucrose (92 g/l.) solution. The width of the centre compartment could be adjusted between 2 and 20 mm. The current (I) applied between electrodes immersed in the side compartments was supplied from a function generator (Hewlett

Packard 3310A). The current (0.024–2400 Hz) intensity and the voltage (V) produced across the centre compartment were displayed on an oscilloscope (Tektronix 565), and the absolute value of the impedance and the phase angle were measured from records of the Lissajou figures obtained at various frequencies.

It was shown in the qualitative experiments that the contribution of the impedance of the plasma membrane was negligible when the frequency was over 5 Hz

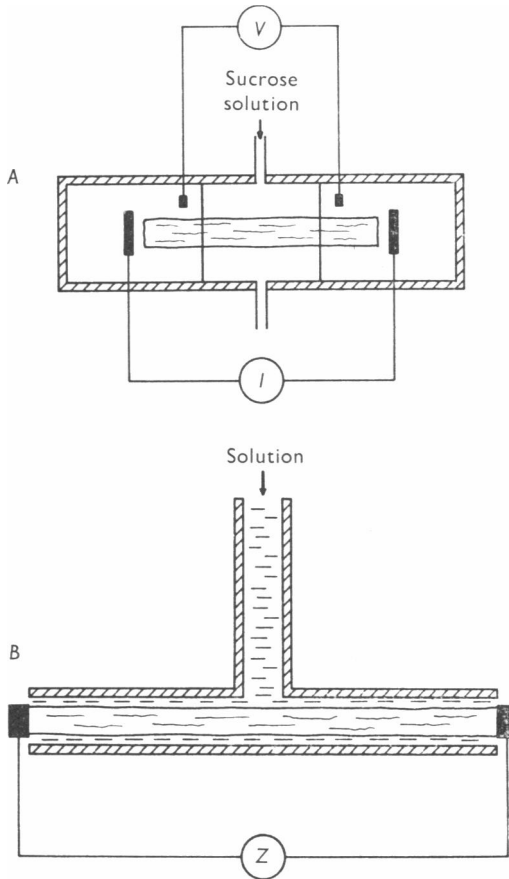

Fig. 1. Diagram of arrangements for impedance measurements. *A*, three-compartment chamber used for qualitative experiments. Side compartments contained Krebs solution and centre compartment was perfused with sucrose solution. Preparation was put through small holes in rubber membranes which separated compartments. Currents were supplied from a function generator (Hewlett-Packard, 3310A) and potential was recorded with an operational amplifier (Teledyne-Philbrick 1009), and they were displayed on an oscilloscope (Tektronix 565-3A3). *B*, small T-tube used for quantitative experiments. A strip of taenia coli was mounted in a horizontal tube. Solution was superfused from a vertical tube at a constant rate of 1 ml./min. Absolute value of impedance and phase angle were directly measured with an impedance meter (Hewlett-Packard 4800).

and the length of preparation was more than 20 mm. Therefore in the main quantitative experiments the longitudinal tissue impedance was measured at a frequency range from 5 Hz to 10 kHz and at an interelectrode distance of 27 mm. In these experiments the preparation was put through a horizontal part of a T-tube (Fig. 1 B) and both ends were fixed at *in vivo* length. Platinum-platinum black electrodes, which were placed at each end of the horizontal tube to make contact with the tissue, were used to measure the impedance. After mounting the preparation in the horizontal tube, it was initially superfused with oxygenated Krebs solution for about 30 min, and then superfusion of isosmotic sucrose solution was started. The absolute value and the phase angle of impedance were measured with a vector impedance meter (Hewlett Packard 4800). The values for all data in the quantitative experiments were expressed per unit volume of the tissue, based on observed impedance, tissue weights (taking the specific gravity as 1.06), inter-electrode distance (27 mm), and extracellular space of 35%.

The impedance of the measuring chambers filled only with sucrose solution was more than 10 M Ω . When the impedance was reduced to about 5 M Ω by adding a small amount of Krebs solution to the sucrose solution, the impedance was constant and the phase angle was almost zero within the range between 5 Hz and 10 kHz. The experiments were all carried out at room temperature (25° C).

RESULTS

The impedance locus and equivalent circuit of the tissue

The impedance (Z) measured at a given frequency was analysed to a real part (R) and an imaginary part ($-X$), and the imaginary part was plotted against the real part at various frequencies to obtain an impedance locus on the complex plane ($Z = R + jX$) where j is the imaginary operator (cf. Fatt, 1964; Cole, 1968). Fig. 2 shows an example of the impedance locus obtained by the three-compartment method after 60 min superfusion with sucrose solution. In this experiment the width of the centre compartment was 2 mm. The locus could be fitted by two different circular arcs. Their characteristic frequencies were around 0.6 and 240 Hz. When the loci obtained after 30, 60 and 90 min superfusion with sucrose solution were compared, it was noticed that the impedance responsible for the left arc (high-frequency locus) was increased with the time of superfusion and that the right arc (low-frequency locus) remained unchanged except a shift to the right due to the shift of the left arc.

When the centre compartment was widened, the left arc moved to the right-hand side and became enlarged, but its characteristic frequency remained roughly the same. The impedance represented by the right arc was not influenced but became difficult to measure as the total impedance was increased by widening of the centre compartment.

In some experiments the preparation was transected at a middle part in the centre compartment (20 mm wide) after 60 min perfusion with sucrose solution. The preparation was fixed by fine pins so that the gap

produced by transection was less than 1 mm. Before transection an average value (three preparations) of tissue impedance was 580 k Ω at 6 Hz and 190 k Ω at 2.4 kHz, and that of the characteristic frequency was 200 Hz. After transection the impedance was increased to 800 k Ω at 6 Hz and 410 k Ω at 2.4 kHz, the difference of impedance between high and low frequencies being the same. Furthermore, the characteristic frequency of the locus did not change.

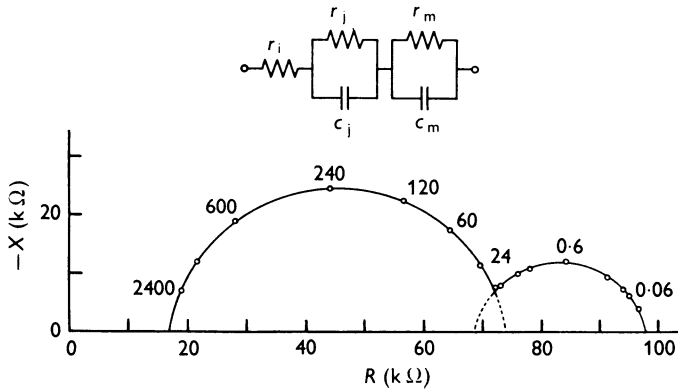

Fig. 2. Impedance locus of the guinea-pig taenia coli obtained across 2 mm sucrose gap after 60 min superfusion with sucrose solution, where R is a real and $-X$ an imaginary part of impedance. Numbers near circles indicate measuring frequencies (Hz). Inset shows an equivalent circuit of the tissue: r_i is the myoplasmic resistance; r_j and c_j , resistance and capacity located between muscle fibres; and r_m and c_m , resistance and capacity of plasma membrane. See text for further detail.

Since the tissue impedance was increased by perfusion with sucrose solution and its recovery was not perfect, it was difficult to compare the results of repeated experiments with different widths of the centre compartment performed on the same preparation. However, the results from many preparations (five preparations with 20 mm width and four preparations with 5 mm width) indicated that the characteristic frequency of the locus of long preparations and that of short preparations was the same (210 ± 30 Hz for 20 mm and 235 ± 35 Hz for 5 mm after 30 min superfusion with sucrose solution). When the impedance of short preparations was subtracted from that of long preparations, as was done by Mobley, Leung & Eisenberg (1975), it was shown that the longitudinal tissue impedance contained the capacity component and that the characteristic frequency of the impedance locus was also the same (220 ± 40 Hz) as before subtraction.

From the above results, it was concluded that, as shown in the equivalent circuit of the inset of Fig. 2, the high-frequency locus corresponds

to the impedance of tissue in a longitudinal direction which is composed of the myoplasmic resistance (r_i) and the junction between muscle fibres (r_j and c_j) and that the low-frequency locus to the impedance of tissue located in the side compartments containing Krebs solution, i.e. probably mainly that of the plasma membrane (r_m and c_m). According to this model the time constant of the plasma membrane shown in Fig. 2 (the characteristic frequency of 0.6 Hz) is about 270 msec. It has been reported that the taenia coli has cable-like properties and its membrane has a time constant of about 100 msec (Abe & Tomita, 1968) and that superfusion with sucrose solution increases the time constant (Kuriyama & Tomita, 1970).

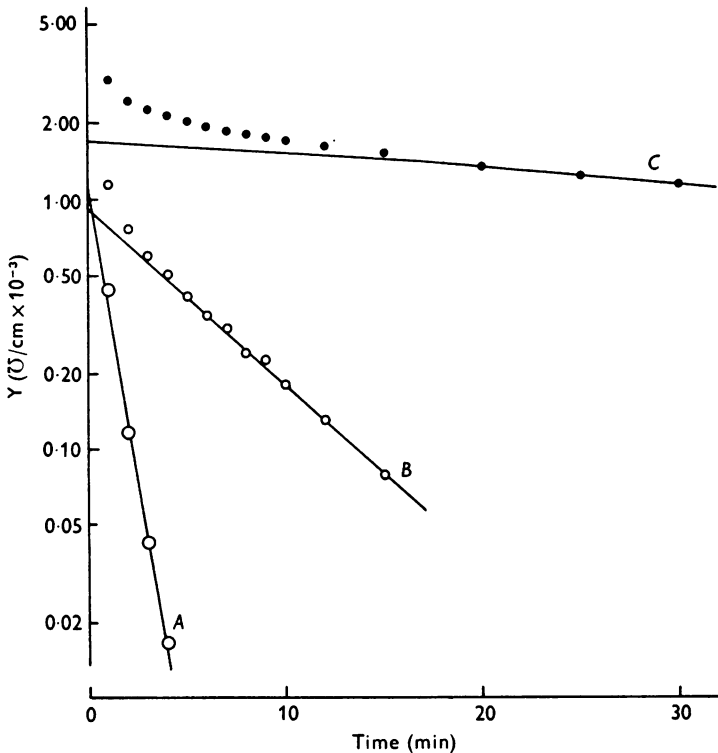

Fig. 3. Time course of admittance, Y , change during superfusion of sucrose solution measured at 10 kHz plotted as filled circles. The curve can be analysed into three exponential components. After 20 min the points can be considered to fall on a straight line (C). The middle component of the curve (small open circles) is obtained by subtracting the line (C) from the experimentally determined points. The values of this second component also can be considered to fall on a straight line (B) after 5 min. Subtraction of this line from the second component gives third component (large open circles), the value for which can be considered to fall on a straight line (A).

Therefore it is reasonable to assume that the low-frequency locus represents the plasma membrane located at both ends of the preparation, and that the impedance of the plasma membrane can be ignored in the following experiments in which the measuring frequencies of over 5 Hz were used.

The time course of changes in admittance during superfusion of sucrose solution

In order to measure the longitudinal tissue impedance, the preparation was set up in the small T-type chamber (Fig. 1B), and the impedance across the horizontal tube was measured within a range between 5 Hz and 10 kHz. When the preparation was superfused with sucrose solution, the impedance was increased with time as previously observed (Tomita, 1969). When the decrease in admittance (1/impedance) was plotted against the time of perfusion, the curve could be satisfactorily expressed as the sum of three exponential terms. This analysis is the same as used for the fluxes of radio-isotope (Brading, 1971). An example of the analysis of the curve obtained at 10 kHz is shown in Fig. 3. The time constant of three exponential terms obtained from six experiments using 10 kHz was 1.3 ± 0.4 min, 6.0 ± 0.7 min and 81.9 ± 26.7 min (mean \pm s.d. of observation) respectively. Although the interpretation of the admittance curve is difficult, it is likely that the change in admittance is related with the decrease in ionic concentrations in the extracellular space and the intracellular space by washing with sucrose solution. The first component has a time constant similar to that of the Na efflux and a time constant of the third component is similar to that of K efflux (Brading, 1971). The first component having a time constant of 1.3 min may correspond to a process of wash-out of the extracellular medium with sucrose solution, and the remaining components to changes in intracellular ionic concentrations.

Since the measurement of impedance at various frequencies (seventeen different frequencies) took more than 2 min, the analysis of time course of admittance change at an early phase (within 5 min) was made only at 10 kHz. When another frequency for the analysis was used, the admittance curve was also expressed by three exponential components. The time course of admittance change was slightly faster with lower measuring frequency, but the first component had more or less the same time constant with various measuring frequencies.

Impedance during superfusion with isosmotic sucrose solution

As shown in Fig. 3, the longitudinal tissue impedance increased with the time of exposure to sucrose solution. In Fig. 4 the absolute values of impedance were plotted against the frequencies at various time intervals

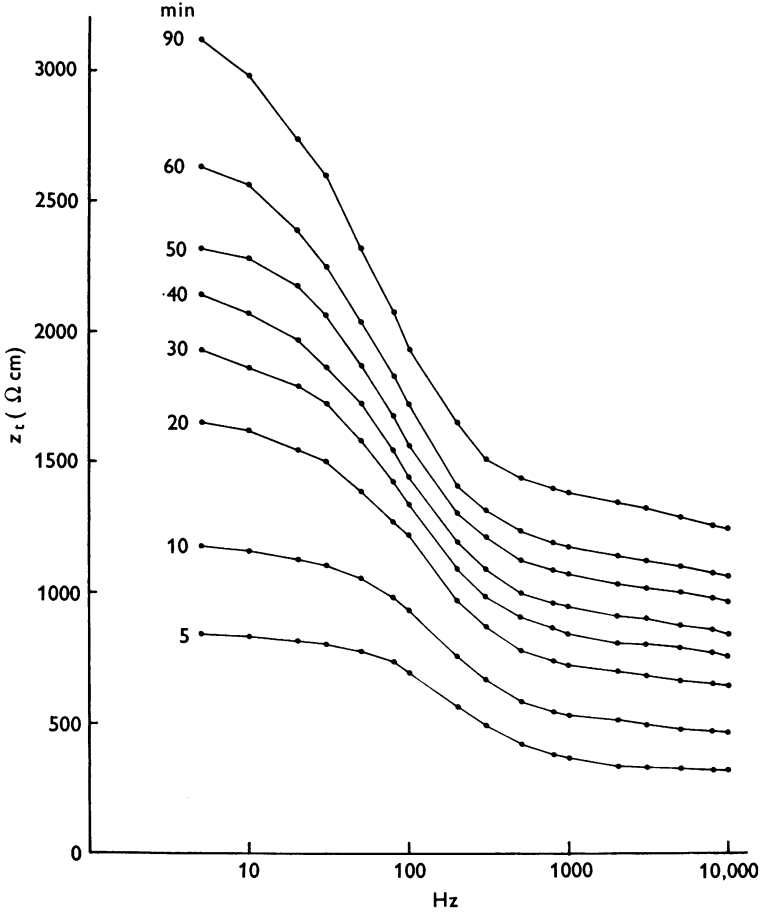

Fig. 4. The impedance, Z_t (ordinate) measured with various frequencies (abscissa) at various times (as indicated by numbers) after starting superfusion with sucrose solution.

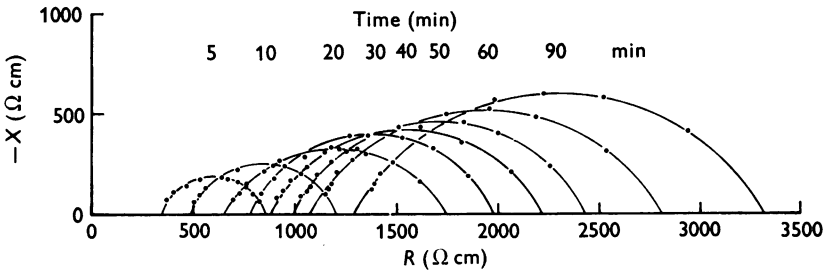

Fig. 5. Impedance loci obtained from the experiments as shown in Fig. 4, where R is a real and $-X$ an imaginary part of the impedance. Numbers on the top of loci represent the time (min) after starting superfusion.

after starting superfusion with sucrose solution. The increase with time was relatively greater at low frequency than at high frequency.

From the absolute value of impedance and also the phase angle at each point of measurements, the impedance locus was drawn (Fig. 5). The real part and the imaginary part of the locus increased with the time of superfusion with sucrose solution. However, each locus could be fitted by a circular arc. The impedances at zero frequency and at infinite frequency were estimated from points of the locus crossing the real axis.

The myoplasmic resistance

The changes in conductance at infinite frequency with time of superfusion were obtained from the analysis as shown in Fig. 5. An example is shown in Fig. 6. The curve of conductance change by superfusion could be fitted by the sum of two exponential terms (g_{11} and g_{12}). The first component observed in Fig. 3 was missing from this curve, probably due to the facts that the measurements were started 5 min after the beginning of superfusion and that 5 min was enough to wash out the extracellular medium. The time constants for exponential changes in the conductance at infinite frequency were obtained from five experiments. The average values were 9.3 ± 2.0 min for the faster component and 103.7 ± 15.4 min for the slower component. They were slightly longer than those for the second and third components obtained at 10 kHz.

An equivalent circuit for the longitudinal impedance of the tissue (Z_t) may be assumed on the basis that the myoplasmic resistance (r_1) is in series with the junctional resistance (r_j) having the capacity (c_j) in parallel (Fig. 7). This circuit is shunted by the resistance of the extracellular medium (r_e). Since the extracellular medium has been washed removing the shunting effect and the measuring frequency is infinite, the conductance shown in Fig. 6 may be considered to correspond to that of the myoplasm (r_∞ in Fig. 7). Thus, if the two components of conductance change reflect changes in intracellular ionic concentrations, the myoplasmic resistance can be estimated from the value of conductance at zero time, which is obtained by extrapolating the exponential change to zero time using the least-squares method, as shown in Fig. 6. The average value ($n = 5$) of the resistance was $214 \pm 42 \Omega$ cm. This was increased to $914 \pm 186 \Omega$ cm after 90 min exposure to sucrose solution.

The junctional impedance

The changes in conductance at zero frequency with time of superfusion could be similarly analysed. If it is assumed that the junctional membrane has a capacity component in parallel, the tissue impedance measured at zero frequency (r_0 in Fig. 7) can be expressed by an equivalent circuit

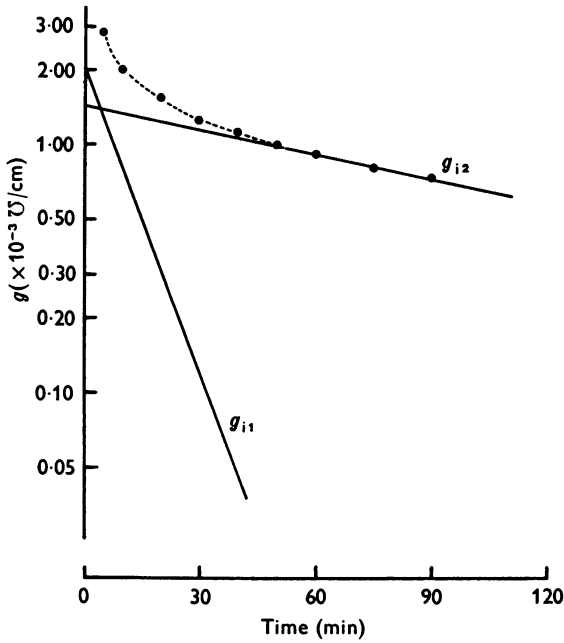

Fig. 6. Change in conductance, g , at infinite frequency during superfusion with sucrose solution. Time course can be expressed by the sum of two exponential components.

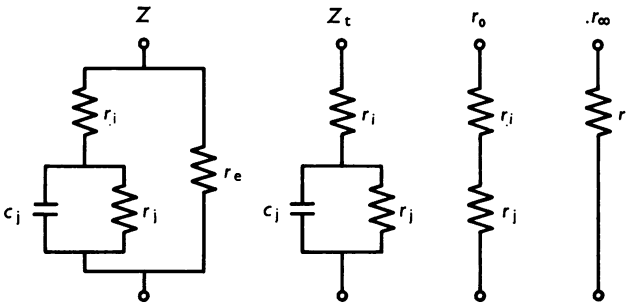

Fig. 7. Equivalent circuits of the tissue under various conditions: Z , total impedance of tissue with shunting resistance (r_e) of external medium; Z_t , tissue impedance after wash-out of extracellular medium; r_0 , tissue resistance measured at zero frequency; r_∞ , tissue resistance measured at infinite frequency; r_i , internal myoplasmic resistance; r_j , junctional resistance, and c_j , junctional capacity.

having the myoplasmic resistance (r_i) and the junctional resistance (r_j) in series, because the impedance of capacity becomes infinite at zero frequency. Thus, the junctional resistance can be estimated from the change in conductance (g_j) which is obtained from the eqn. (1):

$$g_j = \frac{g_\infty g_0}{g_\infty - g_0}, \tag{1}$$

where g_0 is the conductance at zero frequency and g_∞ at infinite frequency (Fig. 8A). When the curve of conductance was extrapolated to zero time, this value would give a value of conductance of the junctional membrane. From these values, the average value ($n = 5$) of the junctional resistance was calculated to be $372 \pm 92 \Omega \text{ cm}$. This was increased to $2120 \pm 316 \Omega \text{ cm}$ after 90 min exposure to sucrose solution. The total tissue impedance at zero frequency was $586 \Omega \text{ cm}$ at zero time and increased to $3034 \Omega \text{ cm}$

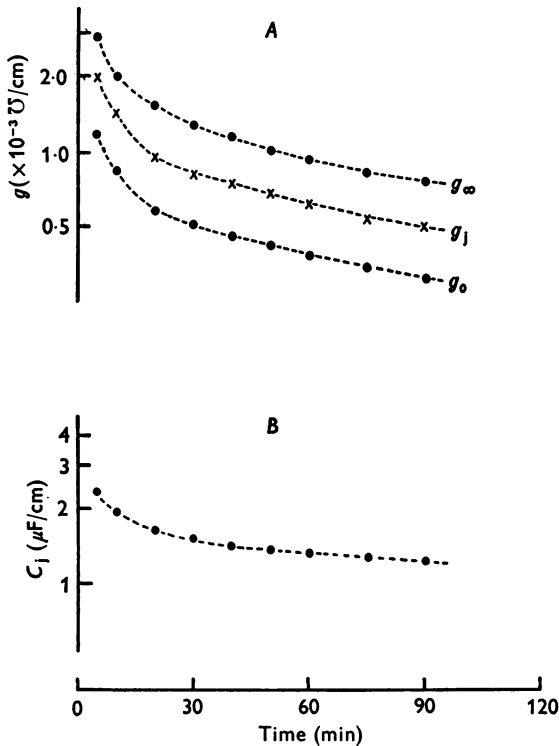

Fig. 8. A, conductance changes at infinite frequency (g_∞) and at zero frequency (g_0). The change in conductance, g_j , was obtained from

$$(g_\infty g_0)/(g_\infty - g_0),$$

which probably represents the conductance of a junction. B, changes in capacity at a junction during superfusion with sucrose solution.

after 90 min superfusion with sucrose solution. The time constant of the increase in resistance was 133 ± 24 min at 90 min.

If the equivalent circuit shown by Z_t in Fig. 7 is used for the tissue impedance, the resistance of tissue (r_t) can be expressed by eqn. (2) taking only the real part of the impedance:

$$r_t = r_\infty + \frac{r_0 - r_\infty}{1 + \omega^2 c_j^2 (r_0 - r_\infty)^2}, \quad (2)$$

where r_∞ is tissue resistance measured at infinite frequency and r_0 that at zero frequency. Thus, the junctional capacity (c_j) can be obtained by using eqn. (3),

$$c_j = \frac{1}{\omega(r_0 - r_\infty)} \sqrt{\frac{r_0 - r_t}{r_t - r_\infty}}, \quad (3)$$

where ω is $2\pi f$ and f is the measuring frequency. In this calculation f was taken as 100 Hz. The capacity tended to decrease with time of superfusion with sucrose solution (Fig. 8B). When the junctional capacity was extrapolated to zero time, the average value ($n = 5$) was $3.1 \pm 0.5 \mu\text{F}/\text{cm}$. The time constant of the junctional membrane was increased with time of superfusion, since the increase in the junctional resistance was larger than the decrease in the capacity. The time constant at zero time was 1.0 ± 0.4 msec ($n = 5$).

DISCUSSION

In the measurement of tissue impedance of smooth muscles, the difficulty arises from the shunting effect of extracellular medium which occupies about 35% of the volume in the guinea-pig taenia coli (Brading, 1971). When a preparation of the guinea-pig taenia coli is superfused with isosmotic sucrose solution in order to remove the electrical shunting, the tissue impedance gradually increases with the time. It is also reported that superfusion with sucrose solution increases the tissue impedance in the mammalian (New & Trautwein, 1972; Kléber, 1973) and the moth cardiac muscle (McCann, Stibitz & Huguenin, 1973). These effects are considered to be due to a loss of intracellular ions (Jones & Tomita, 1967) and to uncoupling of the junction between muscle fibres (New & Trautwein, 1972; Kléber, 1973). Therefore, it is difficult to estimate the impedance of muscle fibres under the normal condition.

A previous attempt (Jones & Tomita, 1967) to evaluate the longitudinal tissue impedance of the smooth muscle was based on measurements made after 2 min washing the preparation with sucrose solution. The impedance was $320 \Omega \text{ cm}$ at 10 Hz and $100 \Omega \text{ cm}$ at 10 kHz at 36°C . However, in these measurements the degree of shunting by the extracellular medium is uncertain. In the next attempt washing with pure sucrose solution was

avoided and the impedance was calculated on the basis of the difference between the impedance in Krebs solution and that in sucrose Krebs solution containing half the normal Na concentration (Tomita, 1969). The impedance obtained from these experiments was 370 Ω cm at 10 Hz and 190 Ω cm at 10 kHz, at 25–28 °C. In this calculation it must be assumed that the cell volume is constant and that the muscle impedance remains the same in two different solutions. These assumptions are not justified.

In the present experiments it is shown that the decrease in the admittance during superfusion with sucrose solution can be expressed as the sum of three exponential terms. It seems reasonable to assume that the first component corresponds to a process of wash-out of the extracellular medium, since this time constant is similar to that of the first component in the Na efflux (Brading, 1971) and is independent of measuring frequency. Thus, extrapolation of the sum of the remaining two components of admittance change would be expected to give an estimate of a tissue impedance in Krebs solution. The values obtained are 586 Ω cm at zero and 214 Ω cm at infinite frequency at 25° C. These values are slightly larger than the previous estimations.

The junctional resistance between muscle fibres measured in a longitudinal direction is the same order of magnitude as that of the myoplasm, when expressed in unit length. If there were electrical shunting between the junctional space and the extracellular space, the tissue which is composed of many cells may not be able to behave like a cable. Since it is shown from the spread of electrotonic potential that the guinea-pig taenia coli has a space constant of more than 1 mm (about ten cell-lengths), it is important to assume that the junctional resistance is well sealed off from the extracellular medium. However, there is no direct evidence on this point.

If it is assumed that the longitudinal impedance of myoplasm is essentially resistive, as in striated muscle fibre (Mobley *et al.* 1975), the impedance which is reduced by increasing frequency probably corresponds to that of the structure, i.e. the junction, between muscle fibres. The resistance and capacity of the junction are estimated to be 372 Ω cm and 3.1 μ F/cm respectively. The time constant of the junction is 1.0 msec. In the Purkinje fibre of the sheep cardiac muscle the time constant of junctional membrane is reported to be 64 μ sec (the junctional resistance 18 Ω cm and the capacity 3.6 μ F/cm) (Freygang & Trautwein, 1970). Although the time constant of junction in the smooth muscle is much larger than that in the cardiac muscle, the ratio of the time constants of the junctional membrane to that of the surface membrane is not much different in both the tissues (1.0/100 = 1.0% in the smooth muscle and 0.06/15 = 0.4% in the cardiac muscle).

The longitudinal resistance of the tissue is estimated to be 586 Ω cm at 25° C. This is increased to about 3000 Ω cm after 90 min exposure to sucrose solution. Although the resistance becomes much higher by superfusing with sucrose solution, it is still much lower than that of sucrose solution, which has a specific resistance of about 1 M Ω cm, and the rate of increase was rather slow having a time constant of about 100 min. Therefore it is concluded from the measurement of the longitudinal tissue impedance that the sucrose-gap method can be applied to the guinea-pig taenia coli.

The authors are grateful to Dr A. F. Brading, Oxford University, for her comments. This work was partly supported by a grant from the Ministry of Education in Japan.

REFERENCES

- ABE, Y. & TOMITA, T. (1968). Cable properties of smooth muscle. *J. Physiol.* **196**, 87–100.
- BRADING, A. F. (1971). Analysis of the effluxes of sodium, potassium and chloride ions from smooth muscle in normal and hypertonic solutions. *J. Physiol.* **214**, 393–416.
- COLE, K. S. (1968). *Membranes, Ions, and Impulses*. Berkeley: University of California Press.
- DEWEY, M. M. & BARR, L. (1962). Intercellular connection between smooth muscle cells: the nexus. *Science, N.Y.* **137**, 670–672.
- DEWEY, M. M. & BARR, L. (1964). A study of the structure and distribution of the nexus. *J. cell Biol.* **23**, 553–585.
- FATT, P. (1964). An analysis of the transverse electrical impedance of striated muscle. *Proc. R. Soc. B.* **159**, 606–651.
- FREYGANG, W. H. & TRAUTWEIN, W. (1970). The structural implications of the linear electrical properties of cardiac Purkinje strands. *J. gen. Physiol.* **55**, 524–547.
- JONES, A. W. & TOMITA, T. (1967). The longitudinal tissue resistance of the guinea-pig taenia coli. *J. Physiol.* **191**, 109–110P.
- KLÉBER, A. G. (1973). Effects of sucrose solution on the longitudinal tissue resistivity of trabecular muscle from mammalian heart. *Pflügers Arch. ges. Physiol.* **345**, 195–205.
- KURIYAMA, H. & TOMITA, T. (1970). The action potential in the smooth muscle of the guinea pig taenia coli and ureter studied by the double sucrose-gap method. *J. gen. Physiol.* **55**, 147–162.
- MCCANN, F. V., STIBITZ, G. R. & HUGUENIN, J. (1973). Studies of impedance in cardiac tissue using sucrose gap and computer techniques. I. The influence of sucrose and oil as insulating media. *Biophys. J.* **13**, 1183–1199.
- MOBLEY, B. A., LEUNG, J. & EISENBERG, R. S. (1975). Longitudinal impedance of single frog muscle fibres. *J. gen. Physiol.* **65**, 97–113.
- NEW, W. & TRAUTWEIN, W. (1972). Inward membrane currents in mammalian myocardium. *Pflügers Arch. ges. Physiol.* **334**, 1–23.
- TOMITA, T. (1969). The longitudinal tissue impedance of the guinea-pig taenia coli. *J. Physiol.* **201**, 145–159.
- TOMITA, T. (1970). Electrical properties of mammalian smooth muscle. In *Smooth Muscle*, ed. BÜLBRING, E., BRADING, A. F., JONES, A. W. & TOMITA, T., pp. 197–243. London: Edward Arnold.