

## A SECOND NEURAL MECHANISM OF BINOCULAR DEPTH DISCRIMINATION

BY COLIN BLAKEMORE, ADRIANA FIORENTINI  
AND LAMBERTO MAFFEI

*From the Physiological Laboratory, Cambridge, CB2 3EG and  
Laboratorio di Neurofisiologia del C.N.R.,  
Via S. Zeno 51, 56100 Pisa, Italy*

(Received 2 May 1972)

### SUMMARY

1. Rotation of an object about its horizontal axis, towards or away from the viewer's eyes, usually causes the images of its contours to have slightly different orientations on the two retinae.

2. We recorded action potentials from binocular neurones in the cat's visual cortex and measured their orientation-selectivity carefully in both eyes.

3. The optimal orientation for a single cell is not necessarily identical on both retinae. For a large sample of cells there is a range of more than  $+15^\circ$  (S.D. about  $6-9^\circ$ ) in the difference of preferred orientation in the two eyes. These interocular differences in receptive field properties cannot be attributed to rotation of the eyes or to the errors of measurement.

4. During simultaneous binocular stimulation the images must not only lie in the correct place on both retinae but also have exactly the right orientation for both receptive fields in order to elicit the maximum response from a neurone.

5. Therefore certain binocular cells respond specifically to objects tilted in three-dimensional space towards the cat, or away from it.

### INTRODUCTION

Cats, monkeys and men are fundamentally binocular animals: their eyes point forward with largely overlapping visual fields, they have conjugate eye movements and true binocular stereoscopic vision (Fox & Blake, 1971; Bough 1970; Wheatstone, 1838). Because the two eyes are horizontally separate in the head, they are looking at the same visual world from somewhat different viewpoints. Stereopsis depends on the detection of small differences in the images on the two retinae, produced by this difference in outlook.

In the geniculostriate visual system of the cat and the monkey massive excitatory binocular combination first occurs in the visual cortex and, not surprisingly, complicated feature abstraction is delayed until messages from the two eyes meet. Neurones in the visual cortex nearly all respond specifically to a linear contour, such as a black-white edge, or slit of light, at a particular orientation, moving across the receptive field (Hubel & Wiesel, 1962, 1968). Different neurones prefer different orientations and the narrowness of the orientational tuning also varies from cell to cell (Campbell, Cleland, Cooper & Enroth-Cugell, 1968).

Apart from orientation, there is another constraint on the adequate stimulus or trigger feature for a binocular cell: the moving object must be at a particular distance from the eyes so that its image is correctly placed on the receptive fields of both retinae. If the object is a little closer or further than the optimal distance, the cell's response may be occluded almost completely, because the positional retinal disparity is no longer appropriate. So each binocular cell is a disparity detector, as well as an orientation detector, and both shape and distance are vital components of the trigger feature (Barlow, Blakemore & Pettigrew, 1967; Pettigrew, Nikara & Bishop, 1968; Joshua & Bishop, 1970; Hubel & Wiesel, 1970). Just as the optimal orientation varies from cell to cell, so does the optimal disparity (Barlow *et al.* 1967; Nikara, Bishop & Pettigrew, 1968; Joshua & Bishop, 1970; Blakemore, 1970*a*) and different cells respond to objects at different distances from the eyes.

It is reasonable to propose that these two processes should go hand in hand. Feature detection and the pairing of correlated features in the two images are essential prerequisites for the recognition of disparity. The two images of a single object, one in each eye, must be identified before their relative positions can be calculated: binocular orientation detectors in the cortex seem to be performing both processes.

Simple positional disparity is not the only discrepancy between the two retinal images that occurs as a result of horizontal separation of the eyes, although it is usually assumed to be the fundamental cue for stereopsis. There are other geometric transformations that the retinal images undergo as a function of the locus, rotation and movement of an object in three-dimensional space. For instance, an object moving across the visual field with a component of movement towards the observer, or away from him, has images with different velocities of movement in the two eyes; a shape rotated about its vertical axis with one side closer to the viewer has images of different horizontal width on the two retinae; an object tilted towards the eyes about its horizontal axis produces images of different orientation in the two eyes. All of these transformations can logically be described in terms of the horizontal disparities of parts of the image, but

such descriptive reductions may only be elegant and economical on mathematical grounds. The nervous system may not use a single geometric convention to analyse three-dimensional space: it might utilize any complex cue available to it.

We have been looking for evidence that binocular cells in the cat's visual cortex are detecting more sophisticated differences between the two retinal images than their precise positions alone. In this paper we attempt to demonstrate that certain neurones have *different* preferred orientations in the two eyes and consequently they respond best to the contours of objects tilted about the horizontal axis towards, or away from, the cat's eyes (Fig. 1).

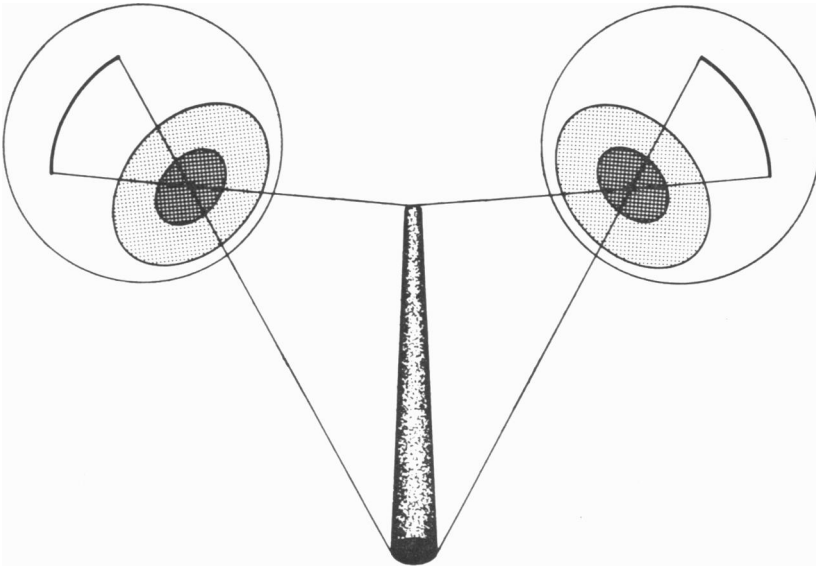

Fig. 1. Imagine the two eyes viewing a long vertical rod in the sagittal plane, with the top tilted towards the animal's head. The two retinal images will be rotated from the vertical in opposite directions, so that the rod appears to the right eye to be somewhat anticlockwise to the vertical, and to the left eye it appears clockwise.

#### *Sign convention for orientation*

We use a 360° scale for the orientation of our stimuli as seen by the cat, thus indicating both the angle of contour and its direction of movement.

- 0° (and +360°): horizontal contour, moving upwards;
- +90°: vertical contour, moving left;
- +180°: horizontal contour, moving downwards;
- +270°: vertical contour, moving right.

## METHODS

We used sixteen adult cats for these experiments, with some minor variations in the preparation, which was basically very similar to that used by Barlow *et al.* (1967). For the rather long initial surgical procedure we anaesthetized the cats with ether or Fluothane, and then Surital (sodium thiamylal) or Brietal (methohexitonesodium). During the period of acute recording, artificial ventilation with nitrous oxide and oxygen (80%/20%) maintained anaesthesia. Sometimes we added 2.5% carbon dioxide to the gas mixture and slightly hyperventilated the animal to avoid hypoxia and yet maintain normal plasma pH. A subscapular or rectal thermistor controlled a heating blanket, which kept the body temperature at 37° C. The experiments usually lasted about 3 days and sometimes up to 6.

*Eye stability.* As in previous experiments on the topography of binocular receptive fields we guarded carefully against movements of the eyes. However, we were concerned only with the orientation of receptive fields and not with the precise positional disparity from cell to cell. Therefore our precautions, while definitely adequate to prevent rotation of the eyes, were sometimes not quite so strict as in those former experiments. We took the following steps to stop eye movement:

(1) an i.v. infusion of Flaxedil (gallamine triethiodide), about 7.5 mg/kg. hr, often supplemented with D-tubocurarine, 0.5 mg/kg. hr, made up in a 6% glucose solution:

(2) bilateral cervical sympathectomy;

(3) the eyes were mechanically held by dissecting the conjunctiva up to its attachment at the limbus and suturing it, or clamping it until dry, on to metal rings, which were then firmly attached to the stereotaxic frame. In the past we have found this method very successful and of all possible residual eye movements after this procedure, rotation is the least likely;

(4) we often suspended the thorax, and sometimes made an open pneumothorax, to reduce pulsation of the eyes as well as the brain.

*Optical quality.* We covered the corneae with plastic contact lenses and 3 or 4 mm artificial pupils. The natural pupils were dilated with homatropine and phenylephrine (Neosynephrine). The refractive state of the eyes, assessed by objective ophthalmoscopy, was corrected for the stimulus surface by lenses placed in front of the eyes. We used a reversible ophthalmoscope to plot out the approximate projections of the areae centrales on a screen in front of the cat.

*The stimulus.* In our simpler experiments, during which we just plotted the receptive fields in a qualitative fashion, we used hand-moved cut-out patterns on an overhead projector, which cast moving black and white shapes on a tangent screen 114 cm from the cat's eyes. For our more quantitative experiments we electronically generated moving dark or light blue-white bars or edges on the P-11 phosphor of two oscilloscope screens, 12 cm in diameter. A single screen, 57 cm in front of the cat, could be used to stimulate each eye in turn while the other eye was occluded; or one screen was shown to one eye and the other, through a small mirror, to the other eye, to stimulate both of them at once. We were able to vary the brightness, width, length and velocity of the bars and, by rotating the screens, their orientations. The orientation of the pattern could be independently manipulated on the two screens and the horizontal and vertical shift controls were also separate; but all the other parameters of the stimulus were identical on the two oscilloscopes. For all the stimuli the dark parts had a luminance of about 1.0 cd.m<sup>-2</sup> and the bright parts about 20 cd.m<sup>-2</sup>.

*Recording techniques.* We made a tiny craniotomy and durectomy, only 2 mm or so in diameter, over the area centralis projection area of the striate cortex. We inserted

varnished tungsten or glass-insulated tungsten micro-electrodes either directly into the opening, using a mechanical microdrive driven by a stepping motor, or through a narrow sealed chamber fixed to the skull, using a hydraulic microdrive. When we did not use a sealed chamber we minimized pulsation by filling the aperture around the electrode with agar.

We used conventional methods for the amplification and display of action potentials, and in the early experiments we simply judged the responses by ear when plotting the receptive fields. In the quantitative experiments, using the stimuli generated on the oscilloscopes, we made each spike trigger a counter, which was gated for a variable length of time by a pulse initiated by the display oscilloscopes. We arranged the delay and duration of this gating period so that it bracketed the time for which the stimulus was passing across the receptive field. In this way the counter accumulated all the action potentials elicited by the stimulus plus any spontaneous spikes produced during stimulation and directly before and afterwards.

We usually collected six successive responses to the stimulus, sometimes more if the variance was high, and were able to calculate the mean number of discharges with its standard error. We also collected the spontaneous activity during the same gating period, in the absence of a stimulus, and if we wished we could simply subtract this from the mean response. The method is only satisfactory when the spontaneous activity is quite low and the response is a regular train of spikes, but fortunately this is the general rule in the visual cortex. In fact we did abandon a very small number of units because their spontaneous discharge frequency was so high that it made analysis very difficult, but in general we found the method a fast and convenient way of analysing responses.

We think this simple method is a very satisfactory alternative to generating post-stimulus time histograms, whose statistics are notoriously difficult to handle. Conventional time histograms, while preserving information about the time course of the response, lose information about its variance. Our method, which is merely the integration of the time histogram, does just the opposite. For simple statistical comparison of responses of similar time course, knowledge of the variance of each response is vital.

## RESULTS

We set ourselves the task of proving that some cells in the striate cortex have slightly different preferred orientations in the two eyes, a task fraught with problems. First, there is the obvious possibility of rotation of the eye during the experiment, but we are very confident that our methods of stabilizing the eye prevented this. In fact, in the early experiments we used the reversible ophthalmoscope to plot and re-plot the optic disks and major retinal blood vessels several times to be sure that the eyes did not move: we could discern no rotation whatever.

Next there is the problem that surgical fixation of the eye obviously can alter the natural torsional position. In order to establish the true vertical and horizontal co-ordinates for each eye we took several photographs of the narrow slit-shaped entrance pupils in the unanaesthetized cat and again after all the surgical preparation. In this way we were able to show that the eyes do not undergo large changes in torsion from moment to moment in the normal alert cat. So, in every cat, we could determine how

much each eye had rotated and correct all the receptive field orientations by the appropriate angle. This allowed us to pool data from many animals since we had an absolute estimate of orientation in each case. Fig. 2 shows drawings traced from the photographs of cat P3, to give an indication of the accuracy of this method. With much practice in the surgery to fix the eyes we can now avoid rotating them more than a few degrees. This method of estimating the true orientation of each eye is still subject to some inaccuracy, so it seemed to us that there was only one foolproof way of proving this point. We had to collect as many units as possible in a single animal and demonstrate that the difference in receptive field orientation between the two eyes varies significantly from cell to cell.

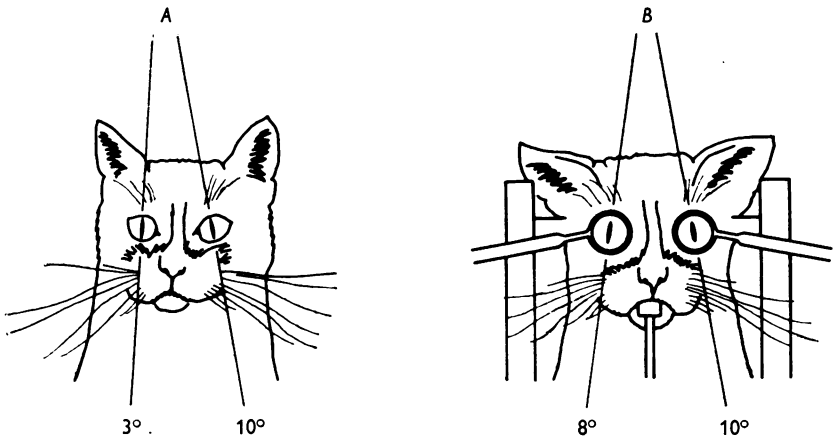

Fig. 2. Tracings directly from photographs of cat P3, taken before (A) and after (B) the preparation for the experiment. The angles of the constricted entrance pupils can be accurately measured in order to assess the rotation introduced by fixation of the eyes. In this case the cat's left eye has not been detectably changed, while the right has been rotated by about 5°.

But now there is another difficulty, for there must be some experimental error in our qualitative estimate of each neurone's preferred orientation. Quantitative methods might produce more reliable results but they take much more time and demand longer experiments. So we finally decided on two approaches. First, we measured the orientational tuning curves quantitatively for as many cells as possible in a single animal, comparing the optimal orientations in the two eyes. Then we studied all the neurones that we could in eleven cats, plotting the receptive fields qualitatively by simple methods and searching only for neurones with narrow angular tuning and optimal orientations that could be estimated reliably.

*Quantitative estimates of orientational tuning*

For this experiment we generated the stimuli on the face of only one of the oscilloscopes and did not put a mirror in front of one eye. We simply studied one eye at a time, for each unit, and determined the orientational tuning through each eye separately, while the other one was occluded.

Before we used the oscilloscope, we plotted the receptive field with the projector and positioned the oscilloscope screen over the centre of the receptive field at a distance of 57 cm. We listened to the responses for various kinds of stimuli and found out the best dimensions and general arrangement of the pattern, including the preferred direction of motion, if one direction was much preferred to the other. Then we generated a bright or dark bar or a dark-light edge of the best dimensions and moved it repeatedly in the preferred direction, and at approximately the best orientation, across the receptive field. Then we varied the velocity of the moving pattern and chose the best speed. Finally, we gradually blanked off areas of the screen, as the pattern kept drifting across it, until the response was abolished. In this way we were able to plot out the so-called *response field* (Barlow *et al.* 1967) very accurately and we made final corrections to the position of the oscilloscope to centre it exactly over the field.

We made each sweep of the stimulus trigger a pulse generator that gated the counter for the period of time that the stimulus was close to, and within, the receptive field. In this way we counted all the impulses produced by each presentation. We recorded usually six, but sometimes more, successive responses and calculated their mean and its standard error. We varied the orientation of the pattern in a pseudorandom series, spacing the determinations at  $5^\circ$  intervals near the best orientation and in  $10^\circ$  steps further away from the peak. We did this separately for both eyes, and also determined the spontaneous activity of each cell by gating the impulses for the same period of time but in the absence of any pattern on the screen.

*Habituation.* In a few cells we noticed marked habituation, as did Hubel & Wiesel (1965), the unit's response declining rapidly with successive presentations. These cells needed several seconds of rest to recover full sensitivity after habituation. In these units we allowed as much time as was necessary to avoid habituation between presentations. In any case, for every cell we always disregarded the first two sweeps of the stimulus at each orientation because they tended to produce slightly larger responses than the rest. By these precautions we avoided any trend in the data from one presentation to the next and hence minimized the variance of the measurements.

*Data reduction.* These quantitative estimates of orientational tuning

showed conclusively that there can be slight differences in preferred orientation in the two eyes, from cell to cell in a single cat. Even in successively studied neurones, with very narrow tuning curves and well defined optimal orientations, the angle between the two receptive fields varied from one unit to another. A good example is shown in Fig. 3A which illustrates the arrangement of the hand-plotted receptive fields for two cells studied within about an hour of each other. The fields are drawn exactly as they appeared on the tangent screen in front of the animal, before any correction for eye rotation (which was very small in this cat: see Fig. 2). In fact the true horizontal and vertical for each eye are indicated on the diagram.

In Fig. 3B, below the receptive fields, are polar diagrams of the tuning curves for these two cells, measured with the oscilloscope patterns, unit P3L8 on the left and P3L6 on the right. Responses from the right eye are plotted as open circles, those from the left eye as solid circles, and again no correction has been applied for the slight rotation of the right eye. Clearly the left eye's preferred orientation is anticlockwise to that of the right eye for P3L8 and clockwise to it for P3L6, and the standard errors of each data point show that these differences are obviously not attributable to the variance of the measurements.

All the data from the binocular cells studied in detail in cat P3 are displayed in Figs. 4, 5 and 6. This is how we decided to treat the tuning curves: first we corrected the orientation axis on all the tuning curves to compensate for the small rotation of the right eye, estimated from the photographs of the pupils before and after the preparation (Fig. 2). Then we considered the tuning functions for the two eyes separately and discovered that the decline of response on each side of the optimal orientation could usually be well fitted with a straight line, just as Campbell *et al.* (1968) found for the response to moving gratings. We used the method of least squares to fit a regression line through the points on one side of the tuning curve, up to the peak of the curve, judged by eye, discarding all the points beyond the first one that differed from the spontaneous activity by less than one standard error. Then we repeated this process for the other side of the tuning curve. (When we judged by eye that the peak of the curve lay very close to one of the data points we included its  $x$ ,  $y$  value in our calculation for the regression lines on *both* sides of the optimum.)

After we had finished this operation on the two tuning curves for each unit we had a good estimate (the intersection of the two regression lines) of the optimal orientation in each eye. Now we superimposed all the peaks of the tuning curves for the left eye by shifting the curves along the orientation abscissa until the intersections of all the regression lines were lined up at zero, marked with a solid arrow, on the abscissa. The



result of this operation is shown on the left in Figs. 4, 5 and 6 where all the left eye's tuning curves are arranged, one above the other. The abscissae are scaled in degrees on each side of the peaks, positive being anticlockwise, negative clockwise. We also performed exactly the same orientational shifts for the corresponding tuning curves in the right eye, and if there were

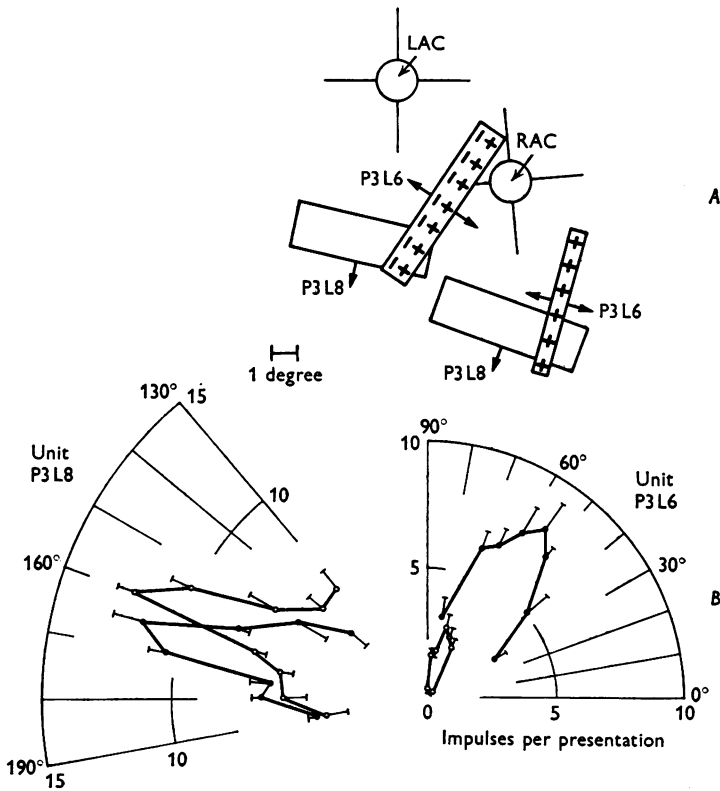

Fig. 3. *A*, the response fields for two cells, plotted within about an hour. The identifying number, near each field, indicates the cat number (P3), the hemisphere being penetrated (L = left) and the number of the unit in the whole sequence for this animal. The simple cell, P3L6, was plotted with flashed spots and bars, and regions of on-responses (+) and off-responses (-) are superimposed on the response field. Arrows, orthogonal to the preferred orientations, show the directions of movement. Complex cell P3L8 was direction-selective. The projections of the left and right areae centrales (LAC and RAC) are shown as circles with true horizontals and verticals, corrected for eye rotation.

*B*, polar plots of the orientation selectivity for the two units. P3L6 on the right and P3L8 on the left. In each case responses in the right eye are plotted as open circles and those in the left as filled circles. The mean number of impulses per presentation of the stimulus is plotted with its s.e. ( $N = 6$ ) on one side.

no true differences in preferred orientation obviously all the peaks for the right eye should also become lined up. The results of this manoeuvre are shown on the right in Figs. 4, 5 and 6, and the abscissae show the difference in preferred orientation: zero, marked with an open arrow, is the expected position of the peaks if there were no actual differences in

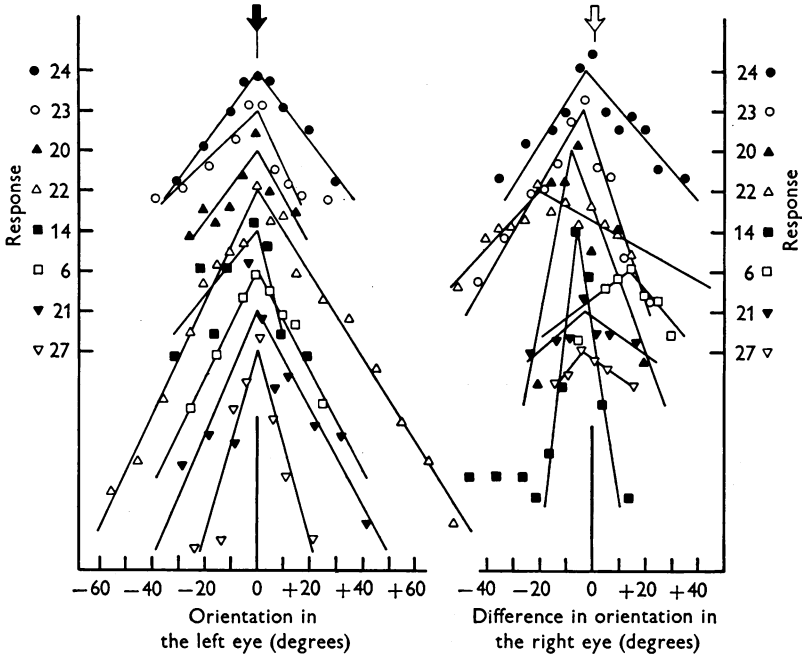

Fig. 4. Orientational tuning curves for the left eye (on the left) and the right eye (on the right) for all the simple cortical cells from cat P3. The details of the graphical manipulations are described in the text. The curves for the left eye have been normalized on the abscissa where zero indicates the optimal orientation. The curves in the right eye, after correction for the rotation of that eye, have been shifted on the abscissa by the same angle as their counterparts in the left eye. This manoeuvre should lead to them all lining up at zero, if there were no differences in optimal orientation. The ordinate is the number of impulses per presentation, but the precise scale varies from one cell to another. The peaks of each pair of tuning curves are lined up opposite the unit's identifying number plus the symbol used to plot the data, marked against the ordinate. Each successive pair of curves is displaced downwards on the ordinate.

optimal orientation between the two eyes. An error in the photographic estimate of eye rotation alone should cause all the peaks to lie to one side of zero. Real (or artifactual) differences in optimal orientation should scatter the peaks along the abscissa, and evidently this is the case.

The scale of the ordinate differs from one unit to another, to allow com-

parison of cells producing vastly different numbers of impulses per presentation. The actual scales are not even indicated, but at least the same scale applies to both eyes for each cell. In every case the two tuning curves have been shifted until the peaks for the two eyes are exactly lined up on the ordinate, and this position is indicated by the identifying number for the neurone and the symbol used to plot its data. The neurones are arranged in no particular order but merely for graphical convenience, each

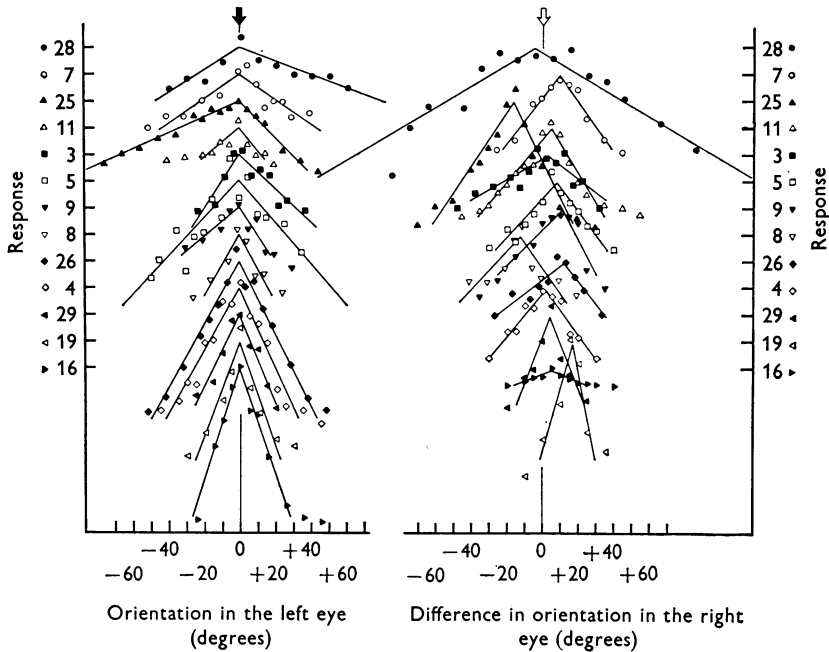

Fig. 5. The complex cells from cat P3 are analysed, as in Fig. 4.

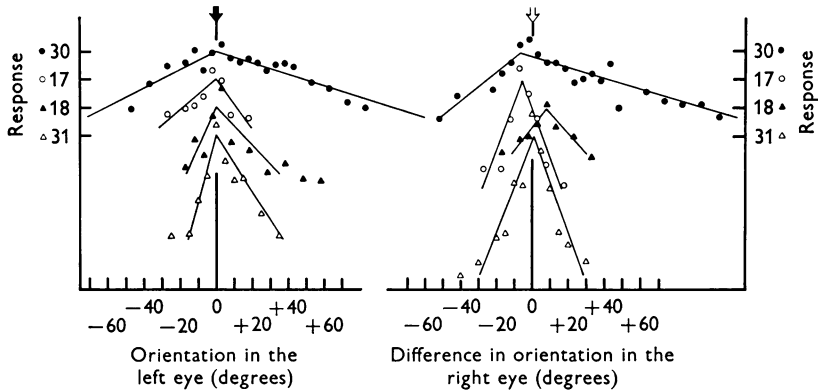

Fig. 6. An analysis of all the hypercomplex cells from cat P3, as in Figs. 4 and 5.

pair of tuning curves being displaced an arbitrary distance on the ordinate. The few missing numbers in this series of neurones belong to the monocular cells that we found, or to units not held long enough to complete the analysis in both eyes.

So Figs. 4, 5 and 6 allow one to compare the relative responsiveness in the two eyes (since the regression lines are in each case extended down to the spontaneous level of firing), the relative narrowness of tuning, and the relative optimal orientation in the two eyes. We classified all the neurones into the simple (Fig. 4), complex (Fig. 5) and lower-order hypercomplex categories (Fig. 6) of Hubel & Wiesel (1962, 1965), using the following working definitions to help us to class the receptive fields.

*Simple cells* have receptive fields that can be plotted with flashing bars of light, and often even with flashing spots. They show fairly simple spatial summation within 'on' and 'off' regions of the receptive field and the best response is obtained with a stimulus that fills an 'off' or 'on' zone. When a bar of this width is moved across the receptive field it evokes a vigorous response. To this extent the responses to flashed targets predict the optimal moving stimulus, but contrary to this idea very many simple cells are truly direction-selective for all moving targets in a way that cannot be guessed from their responses to flashed stimuli.

*Complex cells* sometimes produce weak, ephemeral responses to flashed spots and bars, often 'on-off' all over the receptive field. However, even if they do respond to flashed patterns these responses in no way predict even the optimal width of a moving bar. They do not show spatial summation over the whole receptive field and a narrow moving bar will often produce a strong discharge anywhere within the field.

*Hypercomplex cells* behave like complex cells, but almost never respond to flashed targets, and the receptive field has strong inhibitory zones at one or both ends, so that the optimal stimulus is a bar that is restricted in length. Sometimes the bar must be stopped only at one end, but more often it must be limited at both ends and hence be of a particular length.

A comparison of Figs. 4, 5 and 6 shows, then, that there is a considerable range of differences in preferred orientation between the two eyes but that these differences are not obviously restricted to any one class of cortical cell. Since the largest apparent differences are not necessarily associated with the very broadest tuning curves (for which the error of estimating the peaks is probably greatest) we prefer to believe that most of the differences are real.

The histogram of Fig. 7 shows the distribution of differences in preferred orientation for the twenty-five cells in this sample. We subtracted the optimal orientation in the left eye from that in the right (after correction for eye rotation) to obtain the value shown on the abscissa. Therefore

positive differences in orientation come from cells in which the right eye's preference was anticlockwise to that of the left eye (like cell P3L6 in Fig. 3); such a cell would respond best to a bar tilted with its top end closer to the cat. Negative differences are from cells that respond to contours tilted away from the animal.

The range of the histogram in Fig. 7 is  $36^\circ$  and the best estimate of the population standard deviation is  $9.2^\circ$ .

One important piece of information that is lost in this particular method of reducing the data is the *absolute* orientation of the receptive fields. This is not a trivial matter because tilting a surface forward or backward does not change the orientation of the retinal images for any horizontal contours on the surface. In fact the change in relative orientation of the images for a given rotation of the object decreases as the contour of the object varies between vertical and horizontal. So, ideally, we might have found that there is absolutely no intra-ocular difference in receptive field orientation for neurones with a preference for horizontal lines, since such cells would never be optimally stimulated by natural objects. However, we cannot abstract this information reliably from our data: we do not have a large enough sample to test the variance of intra-ocular differences in orientation for very small ranges of optimal orientation. In any case, even contours very close to horizontal will show some intra-ocular differences in angle when rotated towards the eyes, so perhaps one would not expect to detect any subset of orientation detectors for which there is no range of difference in the two eyes.

We were encouraged by this preliminary study and now moved on to confirm the observation in a number of animals, using simpler qualitative techniques.

#### *Simple estimates of differences in preferred orientation*

For each of the eleven cats in this series we used the projector to plot as many receptive fields as we could, but only considered those that we judged, at the time of plotting, to have very reliable and secure properties. One of our definitions of such a unit was that the total orientational range over which it responded to a moving target was only  $\pm 30^\circ$  or less in both eyes. We always checked the orientational limits as well as the peak of the response by changing the angle of a suitable target sweeping back and forth across the receptive field. Another definition was that it should fall into one of Hubel & Wiesel's (1962) eye-dominance groups 3, 4, or 5: in other words the responses evoked from the two eyes should be reasonably similar in strength, so that neither eye produced ephemeral or irregular responses.

In a few such cells we tried to estimate the accuracy with which we could

determine the optimal orientation by re-plotting the response field several times. We found that we could always re-assess the best orientation to within  $\pm 5^\circ$  or less.

All these demands that we put on the properties of the cells that we wanted to study meant that our total suitable sample in any one cat was rather small, so we had to pool results for all the cats. First, we estimated the twisting of each eye from the photographs and rotated the two arrays

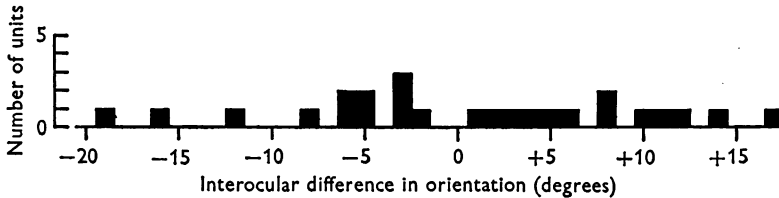

Fig. 7. This is a histogram of the angular differences in preferred orientation for all twenty-five cells from cat P3, analysed in detail in Figs. 4, 5 and 6.

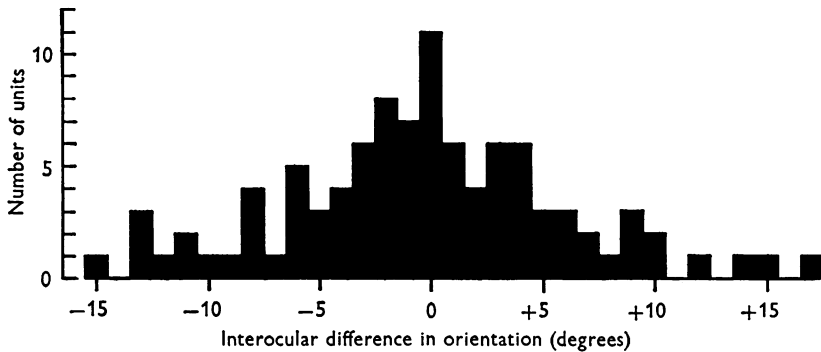

Fig. 8. This histogram, similar to that in Fig. 7, describes ninety-eight cells from eleven cats. The data are pooled by superimposing the individual distributions from each cat, zero being no difference in optimal orientation, after correction for rotation of the eyes.

of receptive fields to compensate for these errors. Then we measured the difference in optimal orientation in the two eyes for each unit, using the same sign convention as for Fig. 7.

We then pooled the data for all 11 cats and the result is plotted as a histogram in Fig. 8. Zero on the abscissa represents no difference in receptive field orientation in the two eyes, after correction for rotation estimated from the photographs. So obviously this histogram is no more valid than the photographic method used for judging torsional movements. However, we think that this procedure is quite accurate and adds very little to the

variance, since every individual cat showed a range of differences in preferred orientation hardly smaller than the pooled range, and the mean of the range was always very similar to the zero difference estimated from the photographs, just as in cat P3 (Fig. 7). Our repeated measurements of optimal orientation suggest that the errors of our methods of plotting receptive fields contributed only a small fraction of the total range of  $32^\circ$  seen in Fig. 8. The standard deviation of this distribution is in fact  $6.3^\circ$ , allowing no loss in degrees of freedom, because the individual distributions are pooled by the superposition of the estimated zero from the photographs, an independent datum for each cat. We also tried superimposing the means of the individual distributions but the statistics of the resulting histogram were very similar to those of Fig. 8.

#### *Simultaneous stimulation of both eyes*

So far we have assumed that the monocular orientational tuning in the two eyes tells us something about the optimal conditions for binocular stimulation. We have implied that any cell will respond best when it finds images of exactly the right orientation on its two receptive fields, and that a change of angle in one eye will reduce the binocular response. We certainly found this to be so in many simple, qualitative experiments in which we projected images on to both receptive fields of a binocular cell (in the manner of Barlow *et al.* 1967) and varied the orientation of the target in one eye. But we decided to try to demonstrate rigorously that this is true.

A small front-silvered mirror in front of the cat's left eye allowed it to see one of the oscilloscope screens, 57 cm away. The right eye saw the other screen straight ahead, at the same distance. First we determined the tuning curve independently in the two eyes, as usual. Then, with the screens carefully centred on the response fields in the two eyes, we generated moving patterns on both of them at the same time. For the two cells that we studied in great detail the stimuli were very thick bright bars on a dark background, in other words, a series of leading and trailing light edges. We gated the response to each successive leading edge, ignoring any discharge for the trailing edge.

Fig. 9 shows the two response fields for a simple cell P6L3, and below them the two monocularly determined tuning curves. We judged the optimal orientation for the right eye to be about  $+345^\circ$  and we set the stimulus on its screen to that angle. We varied the orientation of the stimulus on the other screen, while its brightness and velocity of movement were identical to those for the right eye. We could also vary the *x*-shift and *y*-shift controls of the left eye's screen so that the starting point of the sweep of the stimulus could be changed. In this way we were able to

regulate both the relative orientation and the relative retinal disparity of the stimuli: Fig. 10 explains the arrangement. Varying the position of the whole display on one screen is equivalent to shifting the moving edge closer to, or further away from, the eyes.

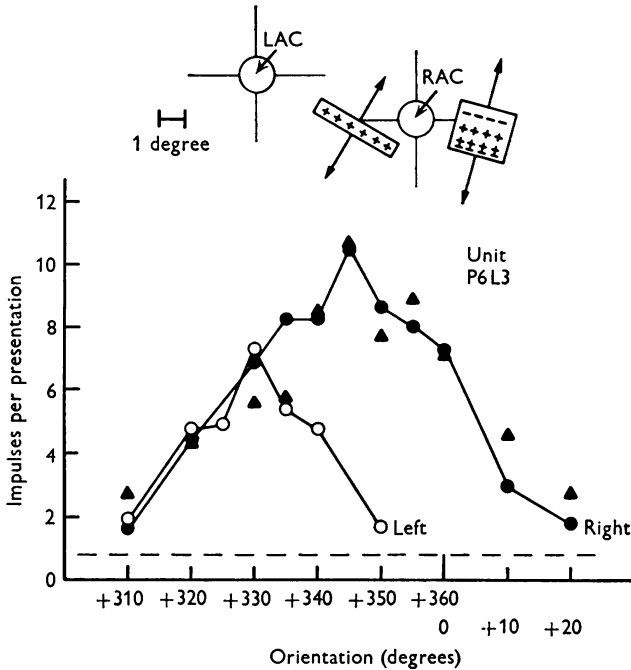

Fig. 9. Above are the two response fields, plotted as in Fig. 3, for cell P6L3. The cell was simple and the areas of on, off and on-off ( $\pm$ ) responses are shown. In this case no correction for eye rotation was found to be needed. Below are the tuning curves for the two eyes determined with a leading bright edge moving across the response field at  $13^\circ/\text{sec}$ . Open circles are used for the left eye and filled circles for the right. The filled triangles are a re-determination of the right eye's tuning more than 8 hr later, after all the analysis for Figs. 11 and 12 was over. The dashed line is the level of spontaneous firing in the absence of a stimulus.  $N = 8$  for every point.

We define the *relative phase* of the patterns as the lead or lag of the edge on the left eye's screen measured along the perpendicular to the optimal orientation ( $+330^\circ$  for this cell) through the centre of the response field, whatever the actual angle of the stimulus. If the edge in the left eye lies relatively to the left of that in the right eye, then the relative phase is positive, *divergent* or uncrossed. If it is relatively to the right the phase is negative, *convergent* or crossed. The *relative horizontal disparity* is the horizontal component of this spatial phase difference and obviously the actual value of this disparity for any particular relative phase varies with



the angle of the edge. In Figs. 11 and 14, the upper abscissa of horizontal disparity applies only to the optimal orientation for the left eye in each case. Rotating the whole display in the left eye is, of course, equivalent to tilting the contour towards, or away from, the cat.

Fig. 11 plots the results of changing both of these variables. The abscissa is the relative phase, zero being when both edges arrive at the centres of their respective response fields at the same moment. The family of curves, plotted with symbols described in the legend, shows the results for different orientations of edge in the left eye.

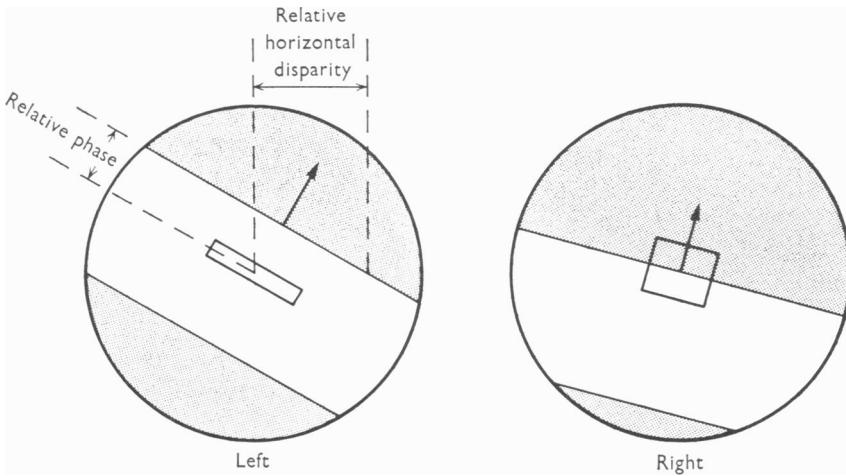

Fig. 10. These are diagrams, to scale, of the views seen by the two eyes during binocular stimulation of cell P6L3. The thick bright bar ( $5^\circ$  across) is shown sweeping over the two response fields, which are exactly in the centres of the two oscilloscope screens. The orientation in the right eye was always  $+345^\circ$ , while that in the left was varied. It is shown at  $+330^\circ$ , the optimal angle for the left eye, and the dimensions corresponding to the relative phase and relative horizontal disparity of the stimulus are shown.

Look at the curve, plotted with solid diamonds, for an orientation of  $+330^\circ$ , the optimum for the left eye from the tuning curve of Fig. 9. When the two edges are exactly in phase as they sweep across the two receptive fields (zero on the abscissa) the cell gives a much augmented discharge, greater than the sum of the two monocular responses, indicated by the solid arrow on the ordinate. But when the stimuli have convergent or divergent disparities, and hence are out of register on the receptive fields, the response is markedly reduced, even below the level for the right eye alone, marked with an open arrow. This facilitation at optimal disparities and occlusion at others has been studied in detail by Pettigrew *et al.* (1968) and Joshua & Bishop (1970).

Now consider what happens when the orientation is changed in the left eye, away from the optimum of the monocular tuning curve. The other curves in Fig. 11 show how both facilitation and occlusion are weakened as the orientation of the edge varies, until edges of entirely the wrong orientation in the left eye (+290 and +370°, plotted as filled and open squares respectively) just produce an over-all slight inhibition of the cells' response, below the level for the right eye alone, at almost all disparities.

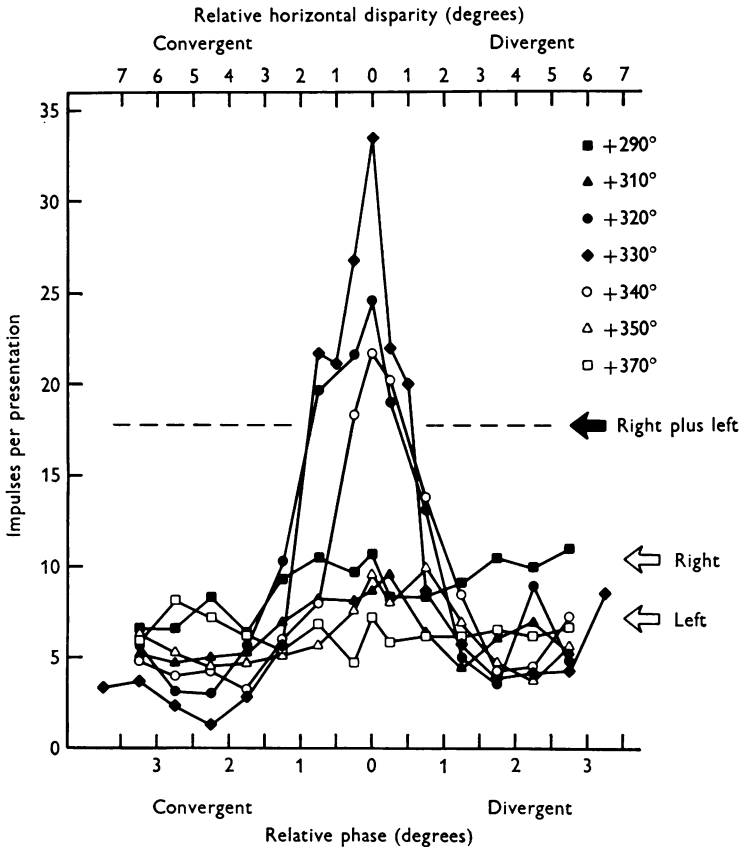

Fig. 11. For cell P6L3 both the relative phase and the orientation in the left eye were varied to generate these results. Each curve, plotted with a symbol described in the inset legend, shows the response at a variety of different relative phases for one particular angle in the left eye. Open arrows indicate the optimal responses elicited from the two eyes alone, while the filled arrow shows the simple sum of the two. The lower abscissa applies to all the curves, but the upper abscissa of relative horizontal disparity is only correct for an orientation of +330°, the optimal for the left eye.  $N = 8$  for each point.

So both facilitation and occlusion, at different retinal disparities, depend on the images being of the appropriate orientation in both eyes, and the best orientation is indeed the peak of the monocular tuning curve. Fig. 12A makes this point particularly clear. The same data as in Fig. 11 are replotted with orientation in the left eye as the abscissa, zero being the optimal orientation. The family of curves shows the results for different

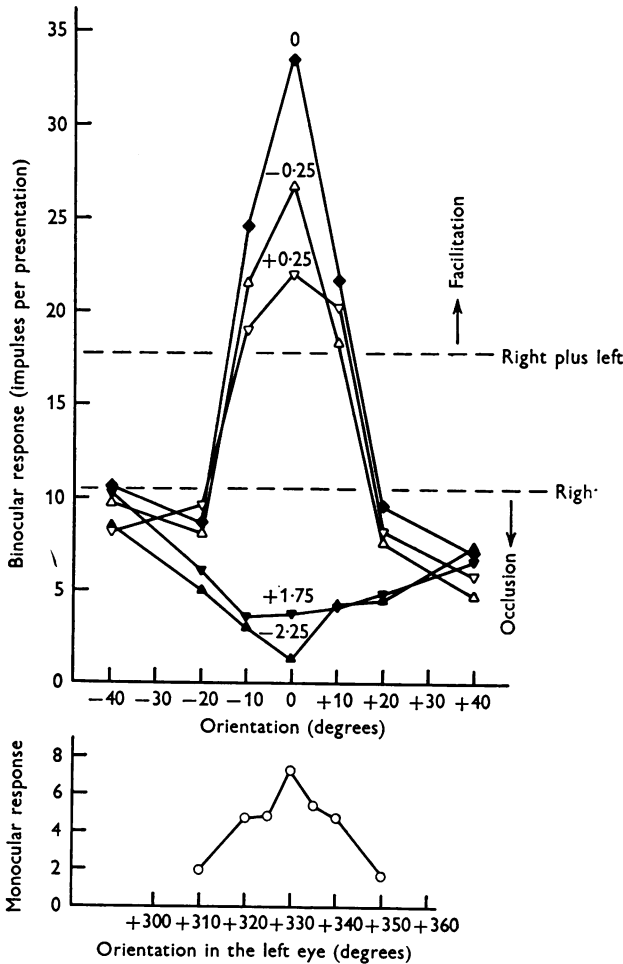

Fig. 12. *A*, some data from Fig. 11 are replotted here with orientation in the left eye, expressed as the difference from the best orientation, on the abscissa. Results are shown for five different relative phases, indicated in degrees against the curves. Dashed lines show the level of maximum response from the right eye alone and the sum of the peak responses for the two eyes.

*B*, this is the monocular tuning curve for the left eye alone, reproduced from Fig. 9, with the abscissa aligned with that for Fig. 12A.

relative phases. At the optimal relative phase (zero), plotted with filled diamonds, the response is best for the optimal orientation (zero), and decreases on each side. At slightly non-optimal phases ( $\pm 0.25$  deg), the facilitation is less marked but is nevertheless still best for the optimal orientation. With very disparate stimuli ( $-2.25$  and  $+1.75$  deg) the occlusion is also strongest at the correct orientation and is reduced for non-optimal angles.

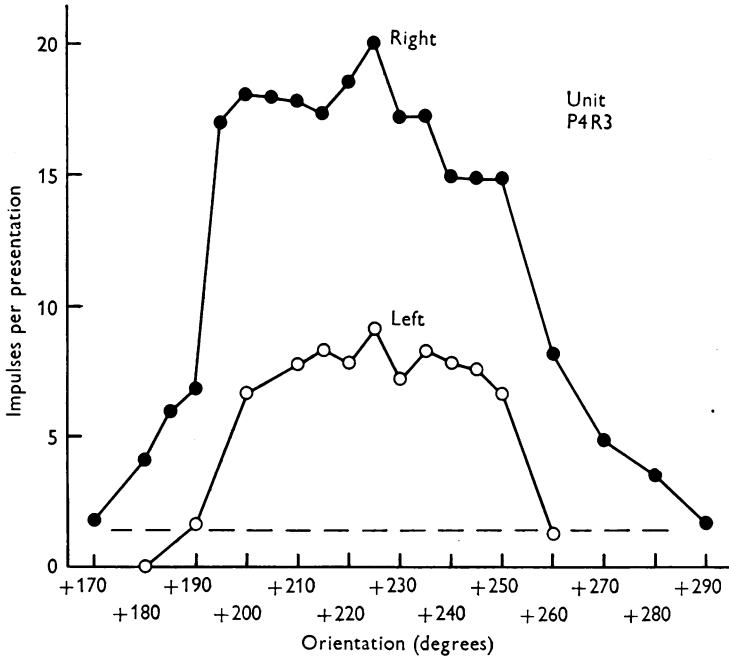

Fig. 13. Monocular tuning curves for the right eye (●) and left eye (○) for complex cell P4R3, plotted as in Fig. 9.  $N = 6$  for each point. Again no correction for eye rotation was needed in this cat.

The shapes of these functions should be compared with the monocular tuning curve for the left eye alone, reproduced below them in Fig. 12*B* with the abscissa in alignment with that of Fig. 12*A*.

Needless to say, an experiment like the one illustrated in Figs. 9–12 takes a very long time: the simple cell P6L3 was reliably recorded for more than 8 hr. Opportunities like this are rather rare but we have repeated the procedure on a complex cell, P4R3, and the results are plotted in Figs. 13 and 14, which are similar to Figs. 9 and 11. For this unit the edge was set to the best orientation ( $+225^\circ$ ) in the right eye and the disparity and angle were varied in the left. The monocular tuning curve for the left eye revealed the best orientation also to be  $+225^\circ$  and indeed the best binocular

response was obtained with that orientation (filled diamonds in Fig. 14). This particular cell did not exhibit strong facilitation, for it merely summed almost exactly the responses in the two eyes when the phase and orientation were appropriate. The extent of this summation was clearly reduced as the angle of the edge in the left eye was altered.

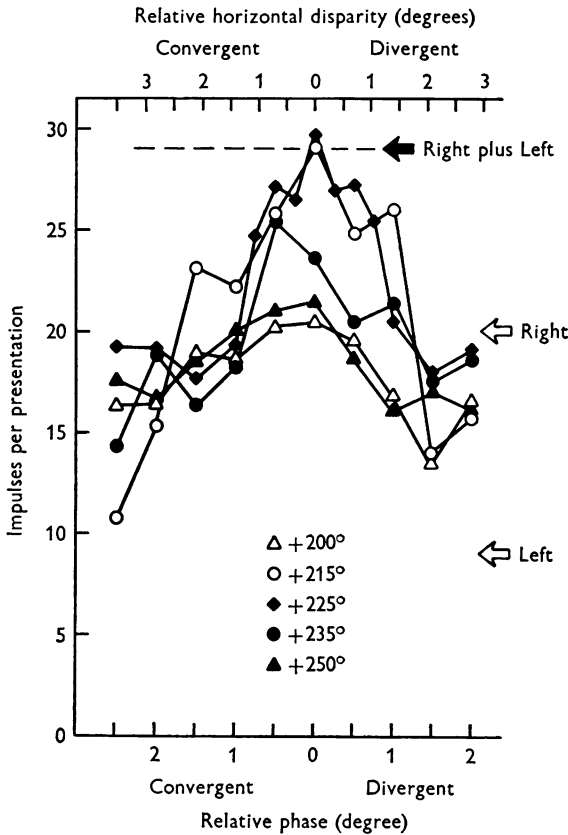

Fig. 14. As for Fig. 11, both relative phase and orientation in the left eye were varied to generate these data for cell P4R3. The orientation in the right eye was optimal (+225°) throughout.  $N = 6$  for each point. The upper abscissa of relative horizontal disparity only applies to the function plotted with filled diamonds for the optimal orientation in the left eye (also +225°).

DISCUSSION

Binocular animals have made a sacrifice: they have abandoned the enormous biological advantage of panoramic vision in order to have their eyes pointing forwards. There is every reason to ask what they get in return and the most obvious advantage is stereoscopic vision. The tiny

differences between the two retinal images contain a wealth of information about the third dimension of visual space and one might expect the animal to use every cue that it can to retrieve this information.

Just because all the geometric differences between the two monocular images can be logically described in terms of positional retinal disparity, this does not necessarily imply that disparity is the only language in which these cues will be read. The visual system might analyse any feature for which a difference between the two retinal images is a cue to depth. We have tried to show that some binocular neurones are specifically sensitive to small differences in the orientation of the image in the two eyes. An analysis of many finely tuned cells from several cats showed a range of about  $\pm 15^\circ$  for the differences in optimal orientation in the two eyes (Fig. 8). Pooling data from more than one cat is not wholly satisfactory, so an analysis of many cells from a single animal is preferable. We did this, measuring the peaks of the tuning curves quantitatively (Figs. 3–6) and we found the range of differences in receptive field orientation again to be more than  $\pm 15^\circ$  (Fig. 7). Our conclusion is that binocular cells can signal the presence of objects tilted about their horizontal axis, towards or away from the cat.

The geometry of this situation is rather complicated. The difference in the orientation for the two retinal images of a contour depends on the interocular separation, the absolute distance and orientation of the contour. As an example, however, if a cat looks down at the ground ahead and sees a contour about 20 cm from its feet, pointing away from the cat exactly in the sagittal plane, the images of the line differ by about  $15^\circ$  on the two retinae. One thing is particularly worth remembering: if the eyes are at their normal torsional angle, any image that is considerably different in orientation on the two retinae must come from an object that is rather close to the animal, so it may act as a cue to the absolute proximity of the object.

Since all the receptive fields in this study came from within about  $10^\circ$  of the area centralis our findings only apply to central vision. For more peripheral receptive fields, whose orientational tuning is often not so precise as that of central fields, this mechanism may not be important.

It is well known that humans can experience a fused binocular percept of a line differing in angle in the two eyes: this phenomenon is called cyclofusion and until recently it was thought to depend largely on torsional movements of opposite direction in the two eyes. However, Kertesz & Jones (1970) tried in vain to measure such movements. They found that long lines (whose mean orientation was horizontal) differing by about  $5^\circ$  on the two retinae could be fused during prolonged observation without any rotational eye movement. Crone (1971) claims that cyclofusional move-

ments do occur, but their maximum amplitude is very small. Braddick (1968) exposed short lines (mean orientation vertical) tachistoscopically and found that up to  $15^\circ$  difference could be tolerated before the lines were ever seen double. They appeared diplopic half the time with a difference of about  $\pm 30^\circ$ . Of course, it is attractive to compare the  $\pm 15^\circ$  range of discrepancy for perfect fusion with the range of differences in receptive field orientation that we have found, and there are even more relevant aspects of Braddick's experiments. He found that the same angular difference can be fused whatever the length of the line up to  $1^\circ$  long. His conclusion was that fusion depends on the analysis of orientation *per se* and not of point-by-point disparity. This is a view with which we sympathize entirely.

Apart from the obvious function of signalling the rotations of objects in depth, cells with different preferred orientations in the two eyes might be used by the cat to adjust the torsional angle of his eyes. If, by chance, one eye rotates away from its correct torsional position, activity will occur mainly amongst those cells with appropriately dissimilar preferred orientations. Perhaps the cat uses this information to set the torsion angle of its eyes to maximize the activity of its cortical cells. A mechanism such as this would provide a function even for neurones with a mean preferred orientation that is horizontal, yet with a difference in angle in the two eyes, although such cells can play no part in depth perception.

Now, to be speculative, consider the other disparities of complex features that could be used to provide stereoscopic information. Rotation of a surface about its vertical axis will produce a difference in the bar-width of vertical lines and an intra-ocular difference in the length of horizontal lines. Blakemore (1970*b*) and Fiorentini & Maffei (1971) performed psychophysical experiments with grating patterns of different bar-width in the two eyes and concluded that the stereoscopic impression depends on an analysis of the periodicity of the patterns and not positional disparity. Fiorentini & Maffei (1970) used similar patterns to elicit occipital evoked potentials and found that the amplitude of the potential increased as the bar-width was made more different in the two eyes.

Objects moving across the visual field, and with a component of movement away from the fronto-parallel plane, have different velocities on the two retinae; in the extreme, an object moving directly towards or away from the viewer has images that move in different directions in the two eyes.

So the images of objects in three-dimensional space can differ in position, bar-width, length, orientation, velocity and direction of movement in the two eyes. Can it be a coincidence that this list corresponds exactly with the features for which cortical neurones are known to be specifically

sensitive? We have seen two binocular neurones with opposite direction-selectivity in the two eyes and there may well be cells that differ in their velocity, bar-width and bar-length preference on the two retinæ. Perhaps cortical neurones are specifically tuned to those complex features of the retinal image for which intra-ocular differences carry information about three-dimensional space.

C.B. received a grant from the Royal Society's European Programme in order to visit Pisa. The research was supported by grants to A.F. and L.M. from the Consiglio Nazionale delle Ricerche and a grant to C.B. from the Medical Research Council (No. G970/807/B). We are very grateful to R. D. Loewenbein and J. S. Dormer for excellent technical help. These experiments were performed in the Physiological Laboratory, Cambridge and the Laboratorio di Neurofisiologia, Pisa, Italy.

## REFERENCES

- BARLOW, H. B., BLAKEMORE, C. & PETTIGREW, J. D. (1967). The neural mechanism of binocular depth discrimination. *J. Physiol.* **193**, 327-342.
- BLAKEMORE, C. (1970*a*). The representation of three-dimensional visual space in the cat's striate cortex. *J. Physiol.* **209**, 155-178.
- BLAKEMORE, C. (1970*b*). A new kind of stereoscopic vision. *Vision Res.* **10**, 1181-1199.
- BOUGH, E. W. (1970). Stereoscopic vision in the macaque monkey: a behavioural demonstration. *Nature, Lond.* **225**, 42-44.
- BRADDICK, O. J. (1968). Binocular fusion and perceptual analysis. Ph.D. Thesis, University of Cambridge, Cambridge, England.
- CAMPBELL, F. W., CLELAND, B. G., COOPER, G. F. & ENROTH-CUGELL, C. (1968). The angular selectivity of visual cortical cells to moving gratings. *J. Physiol.* **198**, 237-250.
- CRONE, R. A. (1971). Human cyclofusional response. *Vision Res.* **11**, 1357-1358.
- FIorentINI, A. & MAFFEI, L. (1970). Electrophysiological evidence for binocular disparity detectors in human visual system. *Science, N.Y.* **169**, 208-209.
- FIorentINI, A. & MAFFEI, L. (1971). Binocular depth perception without geometrical cues. *Vision Res.* **11**, 1299-1305.
- FOX, R. & BLAKE, H. R. (1971). Stereoscopic vision in the cat. *Nature, Lond.* **233**, 55-56.
- HUBEL, D. H. & WIESEL, T. N. (1962). Receptive fields, binocular interaction and functional architecture in the cat's visual cortex. *J. Physiol.* **160**, 106-154.
- HUBEL, D. H. & WIESEL, T. N. (1965). Receptive fields and functional architecture in two non-striate visual areas (18 and 19) of the cat. *J. Neurophysiol.* **28**, 229-289.
- HUBEL, D. H. & WIESEL, T. N. (1968). Receptive fields and functional architecture of monkey striate cortex. *J. Physiol.* **195**, 215-243.
- HUBEL, D. H. & WIESEL, T. N. (1970). Cells sensitive to binocular depth in area 18 of the macaque monkey cortex. *Nature, Lond.* **225**, 41-42.
- JOSHUA, D. E. & BISHOP, P. O. (1970). Binocular single vision and depth discrimination. Receptive field disparities for central and peripheral vision and binocular interaction on peripheral single units in cat striate cortex. *Expl Brain Res.* **10**, 389-416.
- KERTESZ, A. E. & JONES, R. W. (1970). Human cyclofusional response. *Vision Res.* **10**, 891-896.



- NIKARA, T., BISHOP, P. O. & PETTIGREW, J. D. (1968). Analysis of retinal correspondence by studying receptive fields of binocular single units in cat striate cortex. *Expl Brain Res.* **6**, 353-372.
- PETTIGREW, J. D., NIKARA, T. & BISHOP, P. O. (1968). Binocular interaction on single units in cat striate cortex: simultaneous stimulation by single moving slit with receptive fields in correspondence. *Expl Brain Res.* **6**, 391-410.
- WHEATSTONE, C. (1838). Contributions to the physiology of vision. Part the first: On some remarkable and hitherto unobserved phenomena of binocular vision. *Phil. Trans. R. Soc.* **11**, 371-394.